

# Switched OTN for Regional Carrier Networks

## Regional Carrier Market Trends

The network architectures and requirements of regional tier 2 and 3 carriers differ significantly from those of tier 1 carriers, which have already embraced switched OTN as a transport technology. The question at hand is whether or not OTN switching also fits within the regional carrier space. To answer this question, it is important to evaluate the benefits to these carriers of an OTN network versus an alternative network such as a SONET, packet network, or ROADM network.

Past trends indicate that regional carriers and tier 1 carriers generally embrace the same technologies, although perhaps on different schedules. Tier 1 carriers may adopt some technologies first while the regional carriers may lead in deployment of others. However, over time, they generally embrace the technologies exemplified by past SONET, ADSL, FTTH, ROADM, MPLS, and Ethernet deployments.

A simplistic answer to the question posed above could be that, based on these past trends, regional carriers can reasonably be expected to follow the deployment trend of the tier 1 carriers in regards to OTN. But why should the regional carriers do this and if they do, when might it happen?

This paper addresses some of the benefits that OTN might bring to the regional carrier markets.

## Switched OTN versus Dedicated Wavelengths

Switched OTN (or just OTN for short) provides more efficient use of wavelengths than a ROADM network, particularly as the number of hubs increases.

The logic behind this is as follows: assuming that a ROADM network carries traffic from each node to every hub, a dedicated wavelength is required from each individual node to every hub. Each of these dedicated wavelengths is a point-to-point connection between the node and the hub, but the connection could traverse other nodes without picking up traffic from them. For example, a network with two hubs and three nodes would have a total of three unique wavelengths, as shown in Figure 1. These wavelengths would pass through multiple nodes until they reach their destination. With OTN, the wavelength can be shared, as each node can groom traffic to or from the wavelength. In the example given in Figure 1, if traffic is going from Node 3 to Hub 1, it will also pass through Nodes 1 and 2. If there is a slot available on that wavelength, Nodes 1 and 2 can share the wavelength to the hub. A second example is shown in Figure 2.

As the OTUs fill up with payloads, the number of unique wavelengths required to support the traffic eventually reaches the same number as if direct wavelengths were used, as shown in Figure 3. A general trend is the more hubs in the network, the higher the wavelength efficiency of OTN over dedicated wavelengths, since OTN switching can be used to provide better packing of the wavelength segments. However, it is important to consider the cost of OTN switching relative to the cost of these dedicated wavelengths. OTN has the added expense of wavelength termination, OTN switch fabrics, and wavelength regeneration. If these are high relative to a ROADM then, although OTN may have better efficiency in terms of the number of wavelengths used, the actual capital cost of OTN switching may be higher than for dedicated wavelengths.

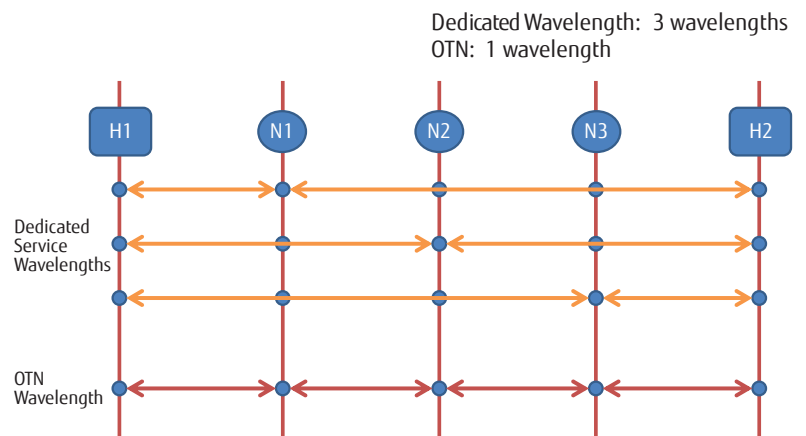

Figure 1: Two-hub, three-node network

In the example shown in Figure 2, it is assumed that the links are all OTU2s with a single ODU0 occupied. In this particular case, a single wavelength for OTN can be used as any one link is only partially filled (six ODU0s in the worst case). OTN provides a 6:1 reduction in the number of unique wavelengths but again, this efficiency needs to be weighed against the regeneration and switch fabric costs of OTN.

## OTN versus Packet

Most, if not all, regional carriers use a packet network. This could be a pure end-to-end MPLS network, or an IP/MPLS metrocore network with a Carrier Ethernet edge.

Due to the plethora of 10M and 100M services in the marketplace, it would be inefficient to use an ODU0 for a single 10M or even a 100M service. This could result in OTU2 (10G) pipes carrying only a fraction of their capacity, which would leave a lot of bandwidth unused. A packet edge network is generally needed to aggregate traffic into larger pipes.

If the edge or access network is a packet network, then an OTN network can be placed in the metrocore to provide some advantages over an IP/MPLS network. OTN does not outright replace IP or MPLS, since routers are still needed at various sites, but it can replace IP or MPLS as a transport layer for the metrocore (see the bullet points below). This could allow for consolidation of routers, providing a significant cost savings, particularly in greenfield applications.

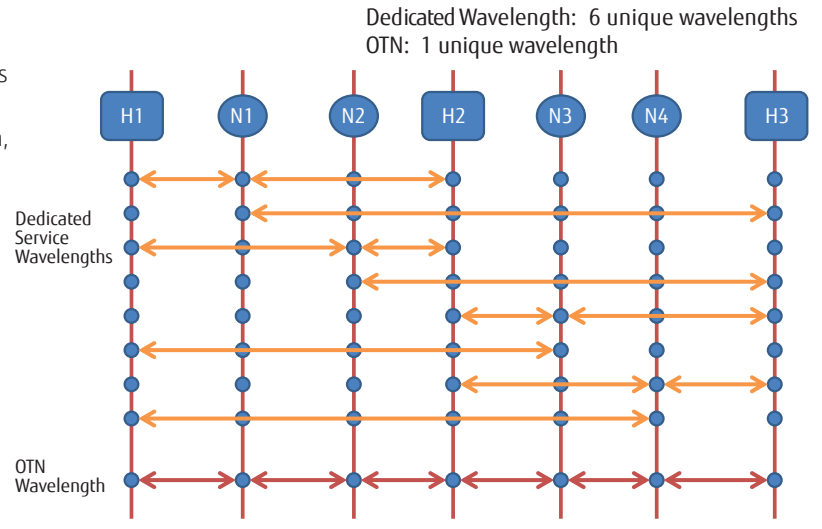

Figure 2: Four-node, Three-hub network

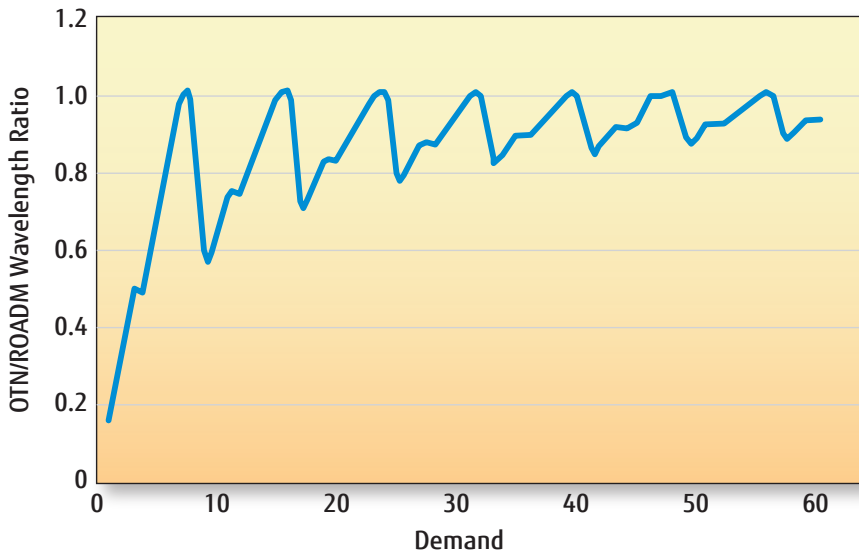

Figure 3: Four-node, three-hub network of OTN/ROADM wavelengths versus demand

## Benefits of OTN in a Metrocore Network

Carriers' primary objectives are always to deliver high-quality service with maximum throughput to a customer. Minimizing any complexity is also of high value. The benefits that OTN switching can bring into a metrocore network can be summarized as follows:

- Improved wavelength efficiency
- Greater flexibility in managing high-speed wavelengths to carry a mixture of services
- Consolidation or reduction of router usage
- Minimal latency
- Minimal jitter
- Maximum throughput via reduced congestion
- Simplified operations via SONET-like operations that eliminate the complexity of a packet network
- Ability to provide transparent services

## Packet Network Designs

Most packet networks are designed such that they do not utilize 100% of the network links. This is a common practice for ensuring SLAs. Underutilization rates of 20% to 50% are common practice. However, this level of under-utilization can result in higher costs as additional wavelengths or higher capacity links may be needed to maintain the excess capacity.

The CIR/EIR of a service as well as the underutilization of the links all need to be well thought out when considering a packet metrocore network. Other potential disadvantages of large complex packet networks (protection switching times, congestion, latency, jitter, and potentially reduced throughput) also need to be considered for the technology transport selection.

## Private-Line Networks versus Pure Packet Networks

Switched packet networks readily transport switched packet services as they aggregate packets together and achieve good utilization of their fiber pipes. However, these networks have challenges when it comes to transporting private-line services. There are methods for transporting private-line services in the case of circuit emulation and pseudowires. However, these methods carry considerable cost, don't scale well, and require special attention to minimize jitter and latency.

OTN networks, on the other hand, transport private-line services quite well. The OTN standard is designed to map all types of private-line services into OTN containers. This allows an OTN transport network to groom these private-line services onto a wavelength alongside other traffic, including packet traffic. This is one of the value benefits of an OTN switched metrocore network, because this type of network easily allows high-speed links such as OTU2s, OTU4s, and eventually OTU5s, to carry all types of traffic, not just packet traffic.

## An Embedded SONET Network

Another significant issue with new technologies is how to migrate older legacy technologies as new technologies are introduced. One method is to "cap and grow." This means that you don't install any new legacy networks, but continue to maintain what is already in the field. Any new services would utilize the new transport technology. The issue with this is that a carrier may end up with parallel networks: at least one legacy and one new technology. This can be inefficient and expensive to maintain.

Another method for the upgrade is to use the new technology as the transport for the legacy network, so that only a single transport network is required and maintained.

A packet network, as stated previously, doesn't transport legacy services like SONET very efficiently. In an OTN network, the SONET and the packet networks can easily share the same facilities. With the grooming capabilities and the SONET/SDH mapping capabilities of OTN, putting these two seemingly disparate technologies onto the same facilities and possibly the same wavelength is simple. With a SONET network and OTN transport, the SONET network elements can remain in place and can keep their protection mechanisms while sharing facilities with other services. This allows the carriers to migrate away from the old technologies at their own pace, without a forklift upgrade, and still maintain a single metrocore transport network during the migration.

## Selecting the Right Transport Architecture

There are four viable options for the transport architecture for packet and private-line services:

- Directly over fiber
- Over a wavelength
- Over OTN over fiber
- Over OTN over a wavelength

A network that can provide packet and private line over fiber (Figure 4) consists basically of routers connected to each other by fiber. The routers provide all traffic switching, congestion control, and also handle any faults that might be encountered. Private-line services would be handled with circuit emulation services (CES) mapped into a pseudo-wire circuit. In this type of network the router expense is high as the routers have to be sized to support any traversing traffic, including the private-line services. However, there is no optical network in place so that the transport cost is low. A network such as this may provide high flexibility in that the routers switch or route to direct traffic to their destination. However a network such as this may have reach issues, may not be able to provide as fast switching over time as other networks, and may need to have special engineering to support the private-line services.

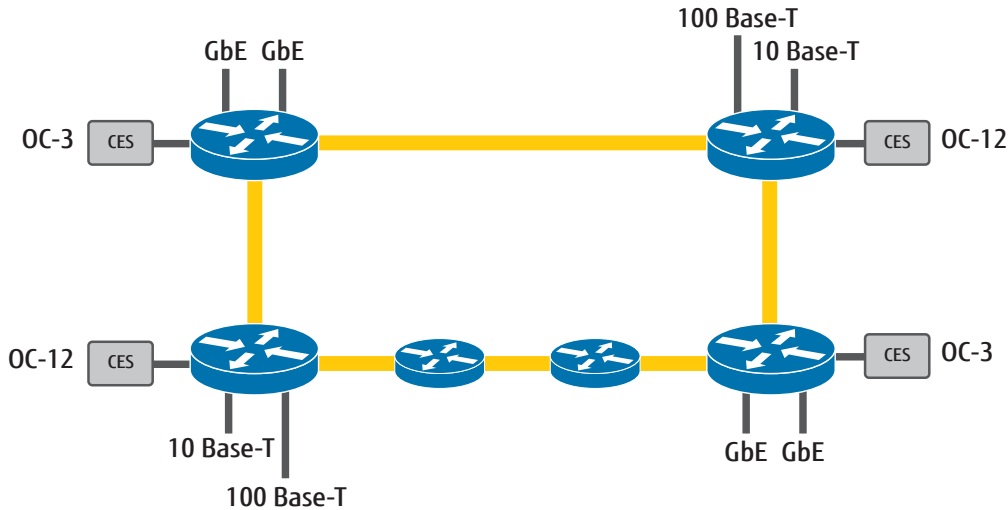

Figure 4: Packet and private-line services over fiber

A packet and private-line over wavelength network (Figure 5) is basically the packet over fiber network but with ROADMs as the transport layer to provide additional capacity and reach. This network can bypass routers, providing expedite paths and reduce some of the router expenses. This network has the added advantage of being able to support private-line services over a wavelength, thus eliminating the need for circuit emulation. However, this type of network may not be as flexible as a purely switched network. The wavelengths are fairly static and might be difficult to rearrange on the fly, and all services put on a wavelength are point-to-point, with no dropping of clients in between.

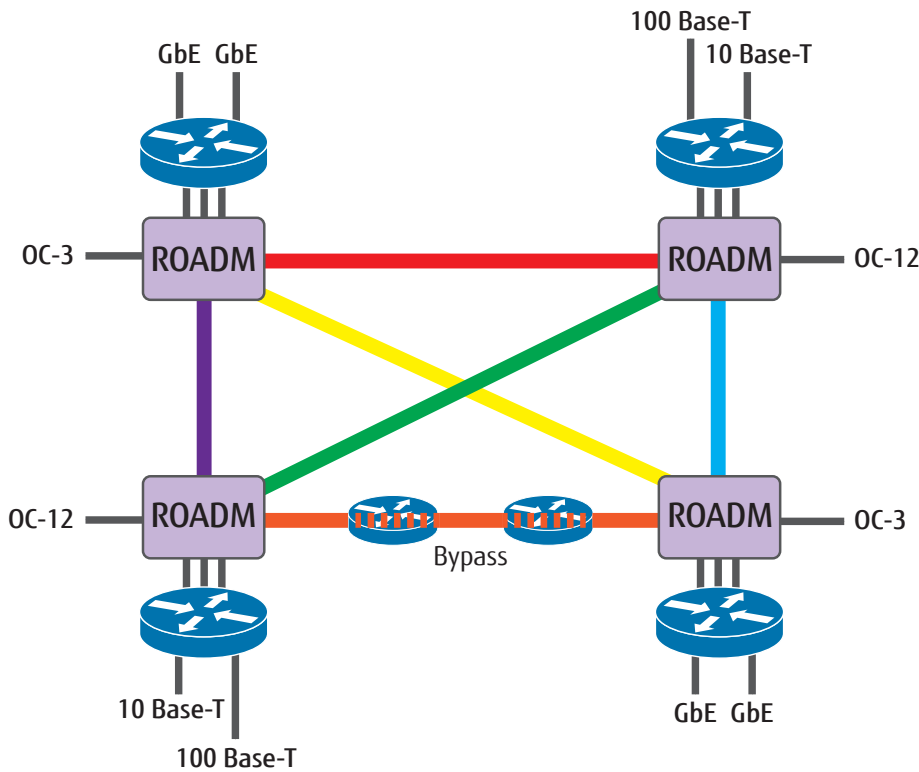
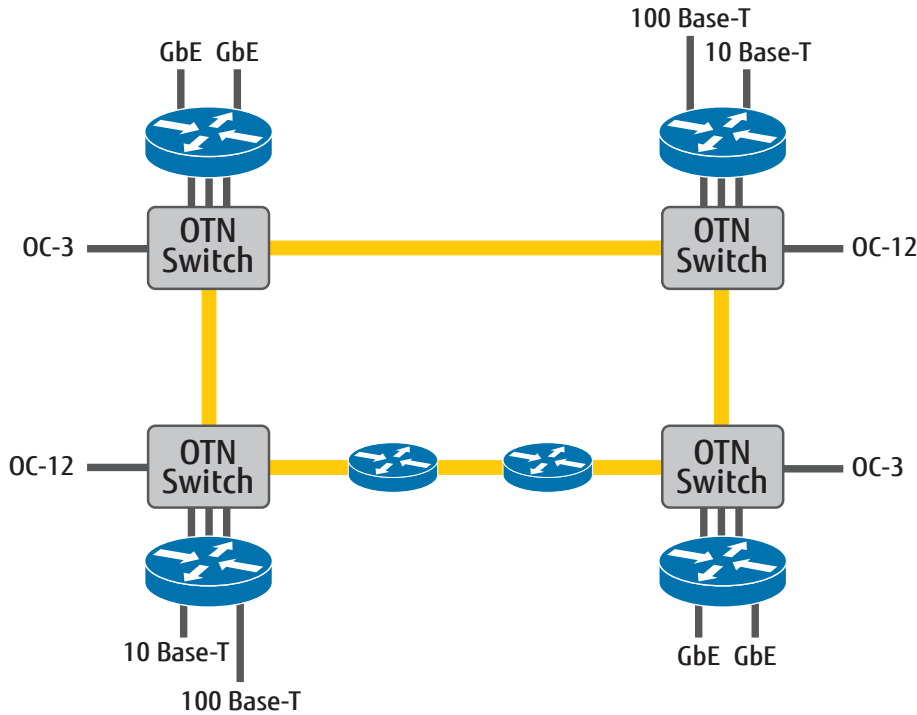

Figure 5: Packet and private-line services over wavelength

A packet and private-line over OTN over fiber network (Figure 6) uses OTN switching as part of optical transport. This network provides the ability to bypass routers with OTN switching which can provide an expedite path. It can be used as a very fast protection layer if a fault occurs. It can also be used to easily drop private-line services to any node, not just end nodes of a wavelength. However, it also incurs the expense of the OTN switching layer which increases the cost of the transport network, as all signals need to be terminated at each terminal, even if the flow is only traversing the node.



**Figure 6: Packet and private-line services over OTN**

A nice compromise is a packet and private-line over OTN over a wavelength network (Figure 7). This network is a hybrid of the packet over wavelength and the packet over OTN over fiber network. It provides wavelength bypass capabilities which eliminates the termination and regeneration of the signal if the wavelength is not dropping traffic to a client which could reduce the expense of traversing nodes. This network also provides OTN switching capabilities so wavelengths can be better utilized, thus decreasing the cost of the transport network. It can also use the OTN switch for fast protection switching. This type of network seems to provide the best combination of attributes overall: high flexibility, lower router and transport cost—while still providing high speed protection and expedited paths for data.

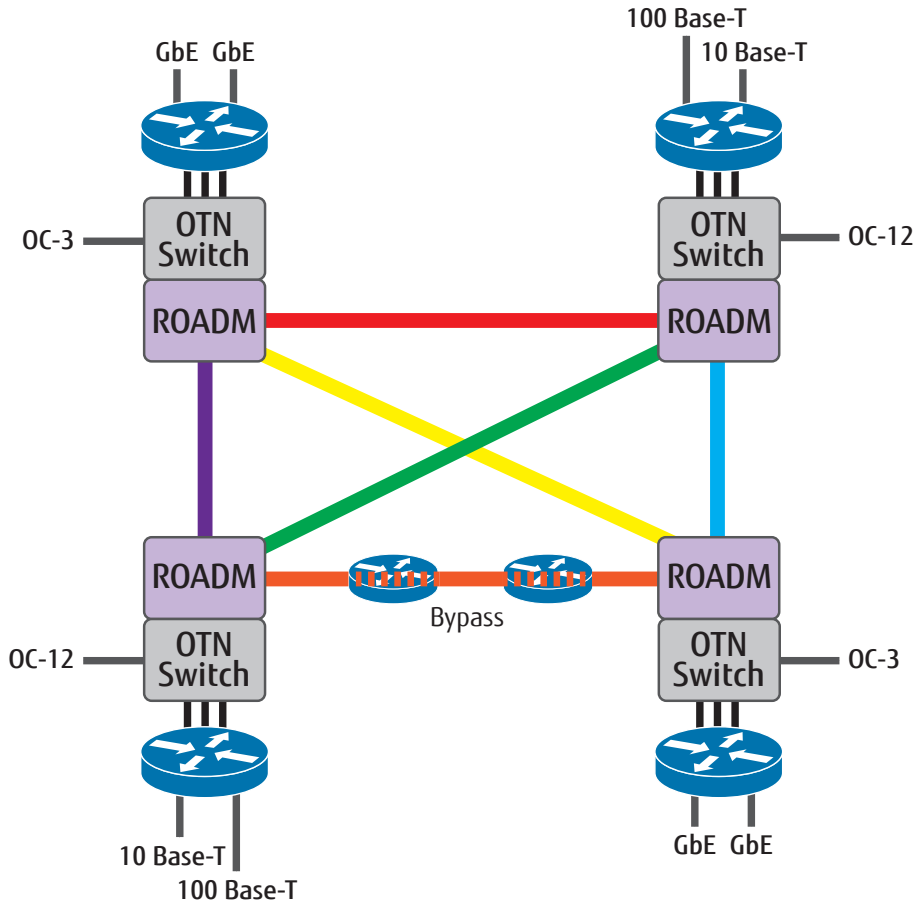

Figure 7: Packet and private-line services over OTN over wavelength



|                                                                                                 | Flexibility                                                             | Router Costs                                                                                   | Transport Costs                                                                                                    | Protection Method          |
|-------------------------------------------------------------------------------------------------|-------------------------------------------------------------------------|------------------------------------------------------------------------------------------------|--------------------------------------------------------------------------------------------------------------------|----------------------------|
| Packet and private-line over fiber – routers connected to fiber                                 | High – all traffic is directed by IP/MPLS                               | High – no router bypass results in more ports and higher capacity of the routers               | Low – assumes direct fiber connect, so no transport costs                                                          | FRR                        |
| Packet and private-line over wavelength – routers connected to ROADMs                           | Low – wavelengths are generally static and might be difficult to change | Medium – assumes some router bypass, however, fixed wavelengths may not provide optimum bypass | Medium – due to addition of the ROADMs in the transport network                                                    | FRR, OUPSR                 |
| Packet and private-line over OTN over fiber – routers connected to OTN switches                 | High – OTN switching and packet switching provide full flexibility      | Low – with OTN switching can achieve optimum router bypass                                     | High – OTN switching with 3-R regeneration at each hop increases the cost of the transport network                 | FRR, OTN protection        |
| Packet and private-line over OTN over wavelength – routers connected to OTN switches and ROADMs | High – OTN switching and packet switching provide full flexibility      | Low – with OTN switching and direct wavelengths, optimum router bypass can be achieved         | Medium – can reduce some of the cost of the transport by not populating OTN switching in nodes that do not need it | FRR, OUPSR, OTN protection |

**Table 1: Packet and private-line services network architecture summary**

## Summary

Regional carriers have not yet fully embraced OTN switching like the tier 1 carriers. They could be taking a “wait and see” perspective to gauge how successful the tier 1 carriers will be before jumping into OTN deployments themselves. They also might not see the need to transition towards OTN switching as have the tier 1 carriers. But if one carefully looks at different networks with different traffic flows, an OTN/ROADM network provides some advantages over other types of transport networks.

Consider an OTN container to be like a virtual wavelength. Since the OTN container allows full transparency of the payload that it is carrying, putting the payload into an OTN container is effectively putting the payload over its own independent wavelength. The payload can be of any type and any size including private line, SONET, Ethernet, Fiber Channel, video, and so on. The containers can fit within any physical wavelength size, a 10G (OTU2), a 40G (OTU3), a 100G (OTU4), or even higher as the rates progress over time. The OTN container is a discrete element of this wavelength that can be switched at every node, or just passed through to the next node. The ROADMs layer provides additional expedite capabilities and can save on transport capital expenses if OTN switching is not required at some of the intermediate nodes.

This provides a universal transport layer that can support essentially all services. The jury is still out on the capital expense of an OTN switching layer; it may be that the initial OTN switching costs are slightly higher than the costs of direct wavelengths due to the recent introduction of the OTN switching technology and this will decline over time as all new technologies do. However, just the operational savings of easily managing high bitrate wavelengths is likely to compensate for this additional capital expense. Furthermore, the simple OAM structure, the improved throughput, and the overall simplicity of this OTN/ROADM network in comparison to a packet network directly over a wavelength are also likely to contribute to reduced operational expenses.

The advent of SDN promises to make the control of this multi-layer network easier to manage and more efficient. With a separated data and control plane, a centralized controller can assign flows to MPLS LSPs, to OTN containers, to wavelengths, etc. real time, allowing better utilization and control of the network. It will understand the traffic at the flow level and can determine which traffic can reside on a bypass wavelength, or within an ODU-flex container within an OTU4, or as a 10G LAN PHY directly connecting two routers.



If a network is very small and carries only packet traffic and is not likely to grow significantly, then a pure packet over wavelength network would likely suffice. However, if this network carries private line traffic, or is fairly large in size or needs additional capacity, or is using an underlying ROADM infrastructure, or needs to carry a SONET-based legacy network, then a switched OTN/ROADM model would likely prove superior to a packet over wavelength network. If you consider both the capital and operational expenses or the cost of maintaining multiple parallel metrocore networks, then a single OTN switched metrocore network is likely to be the best bet for regional carrier markets. As to the question of when tier 2 and 3 carriers might do this, the answer depends on the specific carrier, but if their ROADM nodes are upgradeable to support OTN switching, as is the case with the Fujitsu FLASHWAVE 9500 platform then it could be as soon as now.

## Terms and Acronyms

| Term  | Definition                                  |
|-------|---------------------------------------------|
| ADSL  | Asymmetric Digital Subscriber Line          |
| CIR   | Committed Information Rate                  |
| EIR   | Excess Information Rate                     |
| FEC   | Forward Error Correction                    |
| FRR   | Fast ReRoute                                |
| FTTH  | Fiber to the Home                           |
| IP    | Internet Protocol                           |
| MPLS  | Multiprotocol Label Switching               |
| NE    | Network Element                             |
| OAM   | Operations, Administration, and Maintenance |
| ODU   | Optical Channel Data Unit                   |
| OTN   | Optical Transport Network                   |
| OTU   | Optical Channel Transport Unit              |
| OUPSR | Optical Unidirectional Path-Switched Ring   |
| ROADM | Reconfigurable Add/Drop Multiplexer         |
| SONET | Synchronous Optical Networking              |