

FUJITSU Cash Handling Component GSR50

Scalable Cash Recycler

Overview

The GSR50 is a compact and scalable recycler designed to support multiple industry verticals including retail, financial, transportation, etc. Its basic function, to accept, dispense, recycle denominate and detect counterfeit bills makes it an ideal choice for most applications.

Concept

■ Scalability

GSR50 supports different combinations from an acceptor to a recycler for various environments / usage scene.

■ Excellent validation and easy maintenance

GSR50 is equipped with a bill validation unit to support 256 denominations as well as supporting serial number recognition. Furthermore, easy maintenance work will also be possible because of module base configuration.

■ Sophisticated and compact

The size of an acceptor is very compact. The unit function can be enhanced by piling up additional modules with no change in footprint.

Key Feature

- Cash in/out slot: Semi-bunch mechanism with the short edge first
- Bunch acceptor
- High performance bill validation
- Transport speed: Max. 3 notes/second
- High capacity cash box: Max. 1,500 notes/box
- Selectable configuration of the number of cash box, recycling stacker and loading cassette.
- Exception box for counterfeit as option

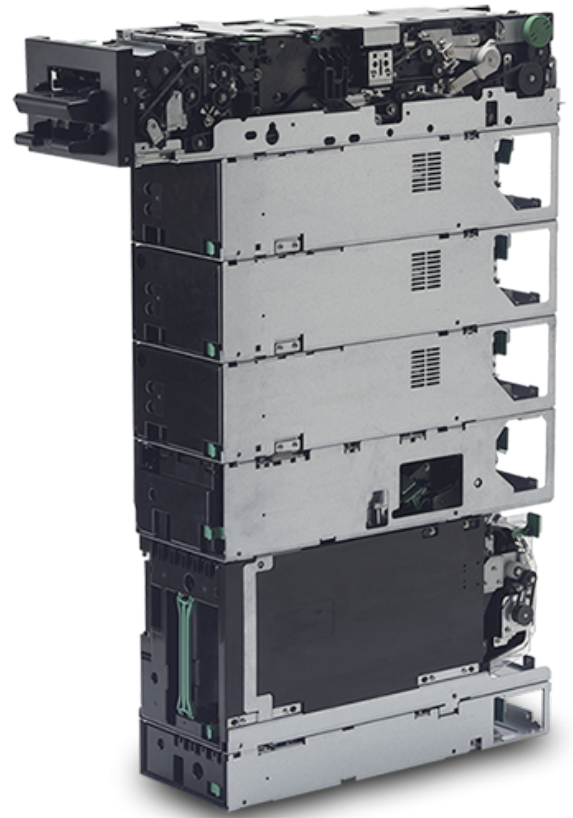

Recycling configuration of GSR50

GSR50 Cash Recycler

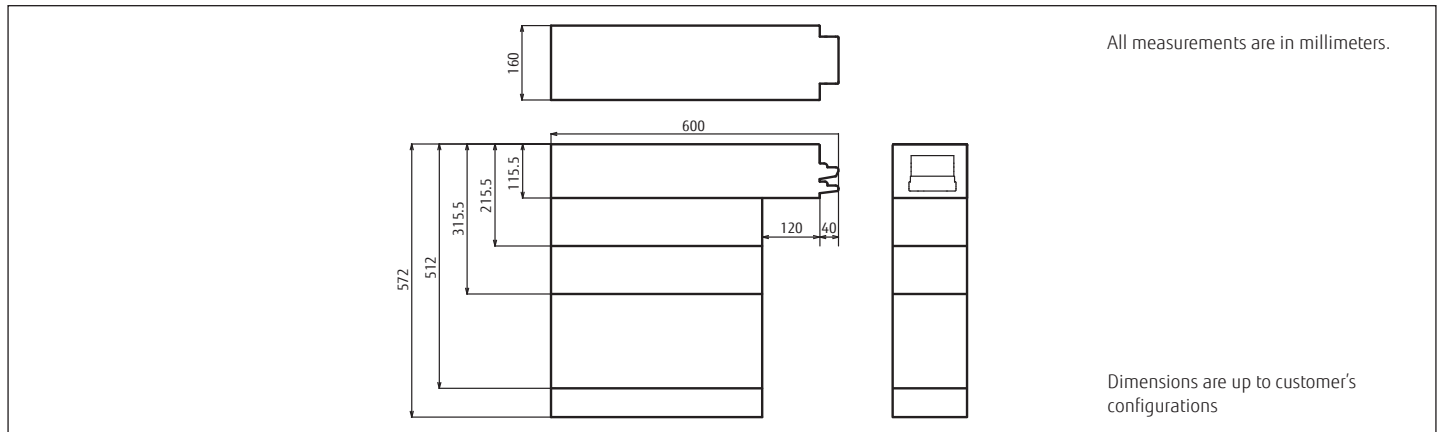

Specifications

Maximum capacity depends on the size and the condition of currency.

Dimension (W x D x H)	160mm x 600mm x 312-800mm	*Up to configuration
Weight	11.7-32.2kg (Excluded notes weight)	*Up to configuration
Acceptable bunch size	10mm height	
Dispensable bunch size	6mm height	
Transport Speed	Max. 3 notes/second	
Capacity		
Cash box	Max. 1,500 notes (Inner area: 225mm)	
Recycling stacker	Dual drum: Max. 60 notes / drum (120 notes / recycling stacker)	
Loading cassette	Max. 500 notes (Inner area: 60mm)	
Exception box	Max. 20 notes (Inner area: 40mm)	

The product specifications are subject to change without prior notice.

Scalability

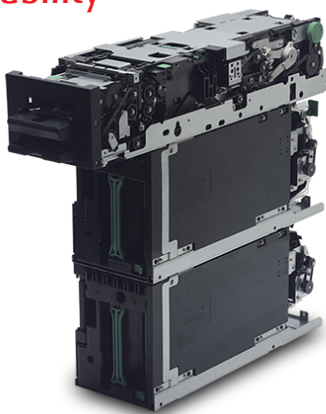

- Cash acceptor
2 cash boxes

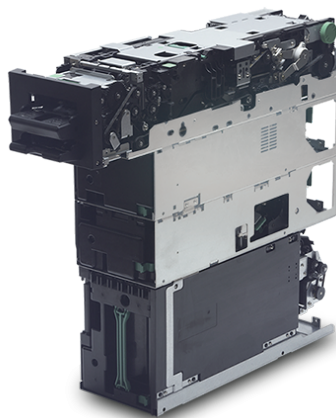

- Cash recycling
1 recycling module, 1 loading cassette & 1 cash box

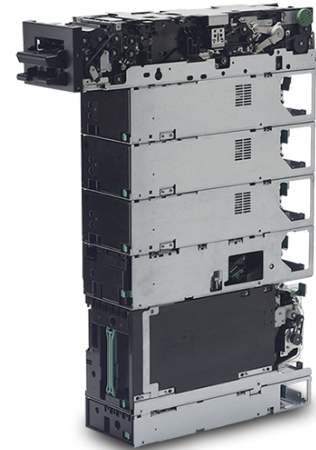

- Cash recycling
3 recycling modules, 1 loading cassette, 1 cash box & 1 exception box

Flexible configuration can be achievable, according to customer's needs. (Max. 800mm height)

Contact

FUJITSU FRONTECH LIMITED

Global Business Group

1776 Yanokuchi, Inagi-shi, Tokyo 206-8555, Japan

<http://www.fujitsu.com/jp/group/frontech/en/>

Inquiry: <http://www.fujitsu.com/jp/group/frontech/en/contact/>