

Fujitsu Optical Transport

Fujitsu Limited



Green Technology

Photoelectric converge technology for reducing environment impact

Integrated Photonics for Green Networking

- Innovative optical transceiver technology for highly power efficient photonic network
 - Use of densely integrated electronic-photonic ICs
 - New optical transceiver architecture adopting function offloads from electronics to photonics

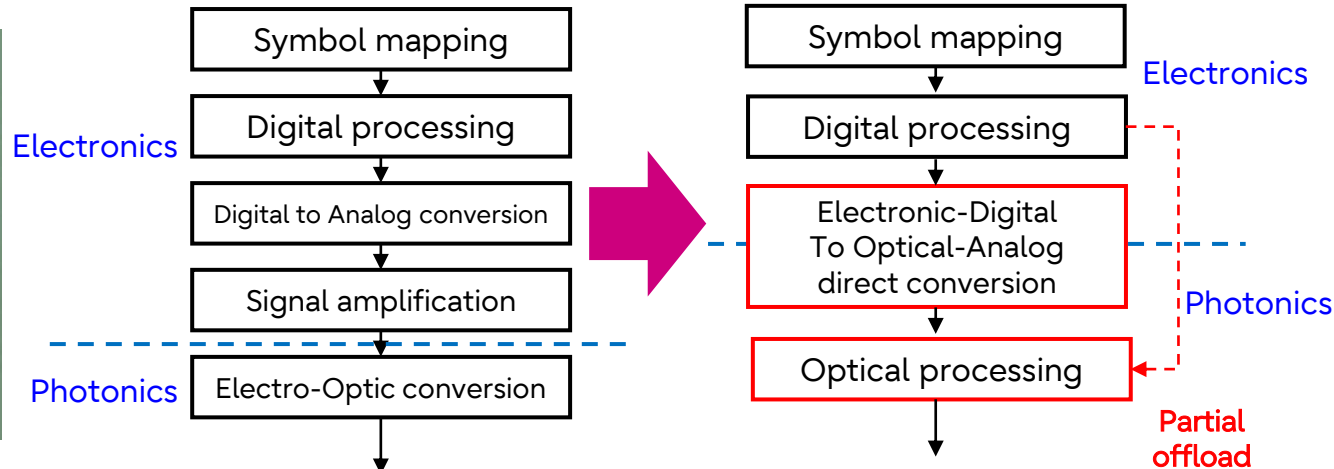
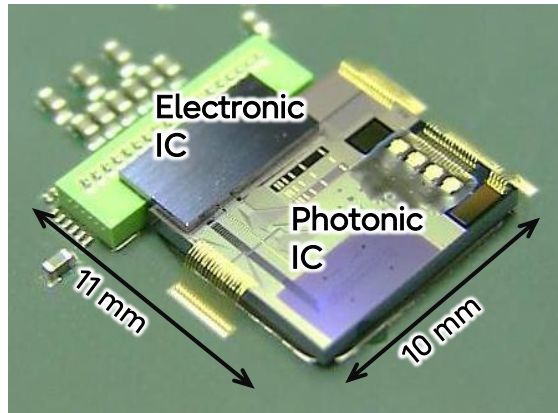

Optical Digital-to-Analog Convertor

- Architectural advantage
 - Eliminates high-speed analog driver amplifier
- Benefit
 - >60% power reduction in optical transceiver

Power consumption

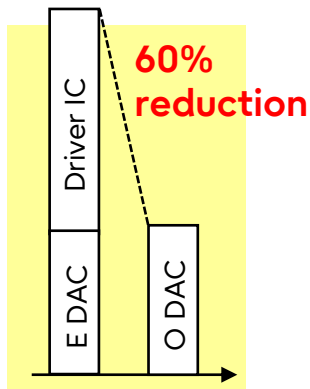

Prototype transmitter

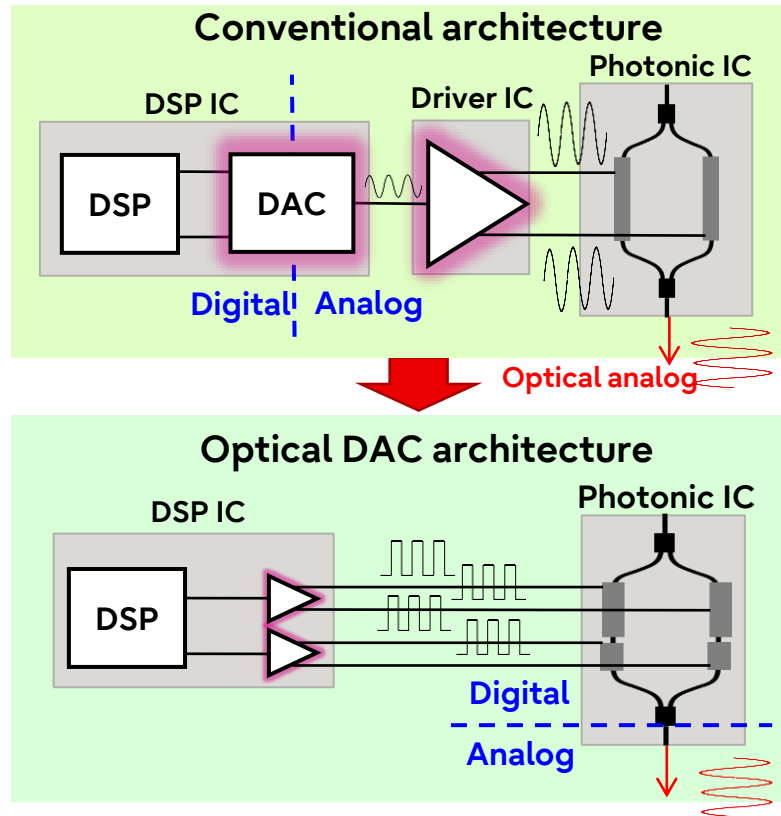
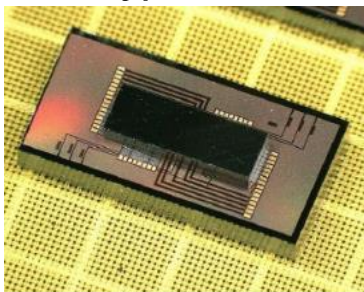

This technology is based on results obtained from a project, JPNP13004, 14004, 16007 commissioned by the New Energy and Industrial Technology Development Organization (NEDO).

Thank you

