

# Technologies for Realizing New ETERNUS LT270 High-End Tape Library System

● Yasuhiko Hanaoka ● Makoto Sasaki ● Akira Takano

*(Manuscript received September 30, 2005)*

The future of magnetic tape as the external memory device of computer systems was once questioned when it lost ground to the optical disk and other devices. However, magnetic tape is regaining popularity because its fast transfer rate and low cost make it suitable for use in fast, large-capacity storage systems. Such systems are in especially high demand for use as backup systems that protect against disasters, but they are also increasingly being used for archival storage. In addition to the requirements of large capacity and high speed, scalability to meet the growth of users' systems is especially important for open systems that handle large amounts of multimedia information. Also important are high reliability, high availability, and continuous operation. Fujitsu has developed a new magnetic tape library called the ETERNUS LT270 that meets today's requirements such as large capacity and high reliability, expandability, and availability. This paper outlines the features and technologies of the ETERNUS LT270.

## 1. Introduction

Fujitsu has been leading the development of magnetic tape (MT) and MT library products for many years. From the initial stage of standalone open-reel tape drives, development moved toward cartridge media with higher user-friendliness and then toward library products with features for automatically handling the media. These products were mostly for conventional mainframes; however, the ETERNUS LT270 introduced here is an MT library for open systems that Fujitsu developed based on the technical know-how we acquired in the mainframe area.

Our first library product for open systems was the ETERNUS LT160 (hereafter the LT160). This product was released in 2002 and has a maximum capacity of 221 cartridges. Our latest model, the ETERNUS LT270 (hereafter the LT270), has a maximum capacity of 709 cartridges and has 2.5 times the storage efficiency of the LT160. It also has dual robots and redundant, hot-replace-

able main components to ensure continuous high-reliability operation.

The LT270 uses second-generation and third-generation LTO (Linear Tape Open) Ultrium drives and features high-speed operation, high reliability, and compactness. It has media control features and environmental control features that, for example, shut down a robot if it starts to vibrate because of an earthquake. To meet today's requirements for strong security, the LT270 offers an optional Write Once Read Many (WORM) feature and an optional encryption feature that uses third-generation LTO Ultrium drive units.

The LT270 MT library can be used as a core product that supports the storage layer of information lifecycle management (ILM), which is one of Fujitsu's development targets. It can also be used in combination with products from independent software vendors (ISVs) and as a virtual tape system, virtual disk library, or archive.

The next two sections of this paper describe the development targets and features of the LT270.

## 2. Development targets

The LT270 LTO library is an enhancement of the LT160, which was announced in 2002. The development targets of the LT270 were as follows:

- 1) Large capacity within the space of a single cabinet  
A world-leading capacity of 700 cassettes
- 2) Library of world-leading quality  
Highly reliable redundant robots, robot controller, power supply, and fans
- 3) Security features  
Optional encryption and support of WORM media
- 4) System administration feature  
Built-in environment sensors and system status monitor

## 3. Features of LT270

The LT270 was developed to meet the market requirements for a large-capacity magnetic tape library with high reliability, expandability, and availability.

The major features of the LT270 are:

- 1) Large-capacity design  
Dual robots and a capacity of up to 709 tape cartridges in a single cabinet. Up to 20 drives can be mounted (with a maximum of 600 tape cartridges).
- 2) High reliability and high availability were realized using dual robots, dual robot controllers, and a redundant power supply configuration.
- 3) Hot-replaceable redundancy  
The robot controller, drive controller, power supply, fans, and entire robot mechanism are hot replaceable (active standby redundancy).
- 4) The Cartridge Access Station (CAS) can remove cartridges from the cells online. Two 10-cassette magazines can be detached at a time.

- 5) Support of enhanced features
  - Optional encryption system
  - Easy to upgrade
  - Cells can be added after entering a software key.
  - Drives can be added by mounting a new cluster (no need to set a World Wide Name [WWN]).
- 6) Flexible connectivity  
Can be used with the following backup software:
  - NetWorker for Sun Solaris (Legato)
  - NetBackup for Sun Solaris (Veritas)
  - TSM for Sun Solaris (Tivoli)
  - ARCserve for Windows (Computer Associates)
  - NetVault for Linux (Backbone)Also, can be used with the following system management software:
  - Softek Storage Cruiser
  - Fujitsu's Systemwalker and remote maintenance.Details are given in Section 3.1 and following sections.

### 3.1 Large-capacity tape storage

#### 3.1.1 Mounting structure and cell array

The square cartridges are arranged in columns and rows, and the mounting efficiency of the system was enhanced by minimizing the dead space (**Figure 1**).

To minimize the dead space, it was necessary to realize a structure in which the robots could move in parallel in three dimensions.

In addition to moving in the X, Y, and Z dimensions, the robot hands swivel around the Y-axis (**Figures 2 and 3**).

Each robot has five different mechanisms:

- 1) Y-mechanism. Moves the robots vertically. The robots are passively kept in position by balancers that weigh the same as the robots.
- 2) Hand mechanism. Loads and picks cassettes into and from the cells, CAS, and drives.
- 3) X-mechanism: Moves the hand mechanism left and right.

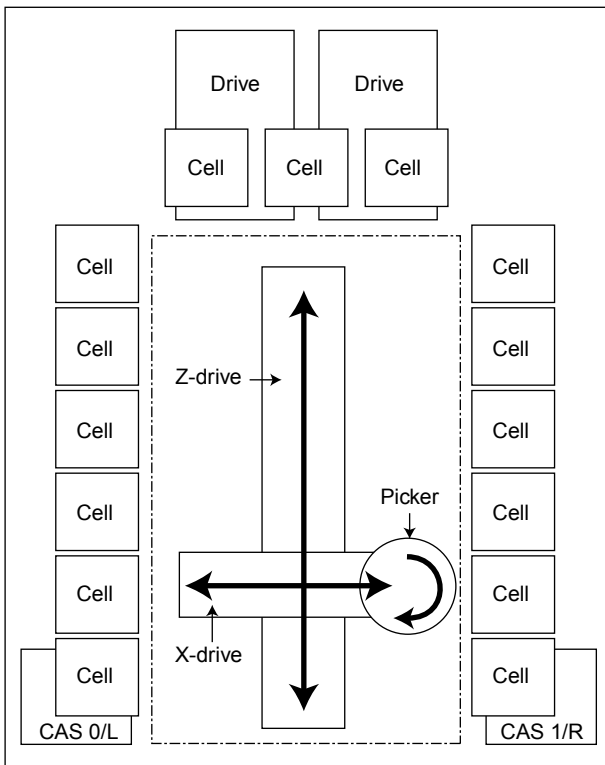

Figure 1  
LT270 cell arrangement (top view).

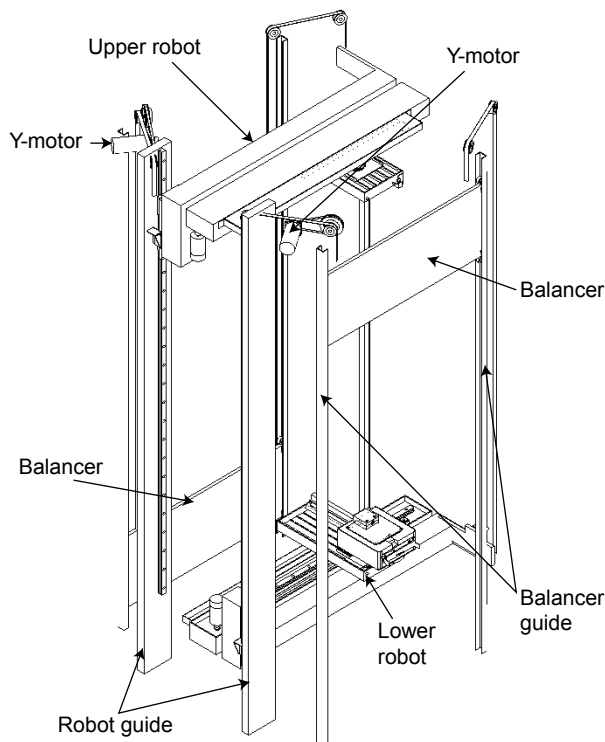
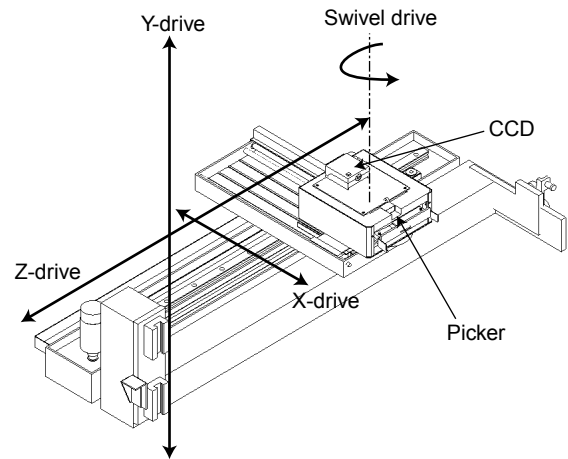

Figure 2  
Robot placement.



CCD: Charge coupled device

Figure 3  
Movements of lower robot.

- 4) Z-mechanism: Moves the hand mechanism back and forth.
- 5) Swivel mechanism: Rotates the hand mechanism to face cells on the sides or rear and the CAS and drives.

### 3.1.2 Drawer structure

If the mounting density of the system is increased, the working space for installation decreases, which might reduce work efficiency.

When a large number of cartridges are to be mounted at the same time, for example, during installation or relocation, work speed can be increased by manually inserting the cartridges into the cells. However, if the mounting density inside the system is high, there might not be enough space to easily access the cells.

To solve this problem, the cartridges cells can be pulled out like a drawer to allow easy access (Figure 4).

### 3.1.3 High-density cell mounting

By using the servo control technology we developed for large-scale tape libraries, we were able to build a high-precision control system using small, lightweight server motors and also achieve high-density mounting of the cartridge cells.

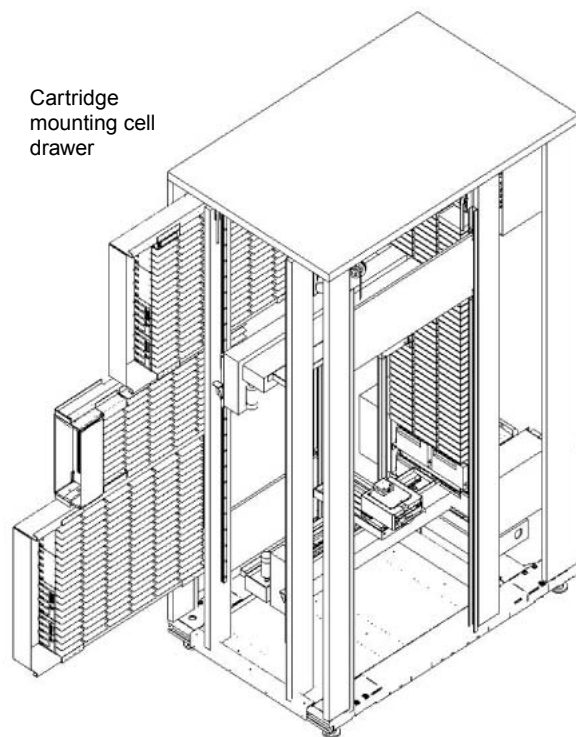

Figure 4  
Removable cells for easy access.

### 3.1.4 Robot mounting

To achieve high-density and large-capacity cartridge mounting and efficient robot mounting, we placed the hot and standby robots in the upper and lower locations, respectively (**Figure 5**). To achieve this arrangement of robot redundancy, we improved the elevators and reduced the footprint.

## 3.2 Redundancy

To ensure continuous operation of the LT270, the following units were made redundant in addition to the robot mechanisms:

- 1) Robot controller
- 2) Drive controller
- 3) Library power supply
- 4) Drive power supply
- 5) Cooling fans

## 3.3 Expandability

- 1) Tape drives  
Up to 20 tape drives can be installed. The

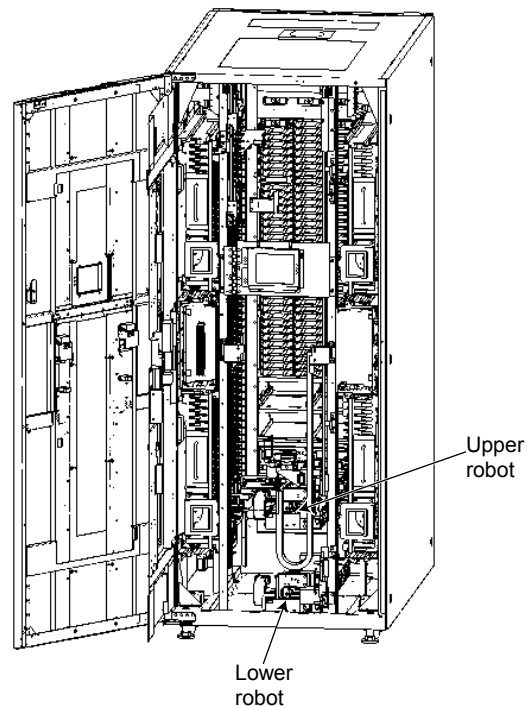

Figure 5  
Robot placement.

drive clusters mount four drives each, and drives can be connected to the power supply and tape library simply by inserting them into a drive cluster (**Figure 6**).

If there are less than 16 mounted tape drives, the user can easily convert the free drive space to mount a cartridge mounting cell.

### 2) Cartridge mounting cell

The LT270 can mount 134, 248, 470, or 709 cartridges according to the number of mounting cells. To minimize operation downtime, users can upgrade simply by obtaining a new license and password on the Web.

## 3.4 Operability

The LT270 has an LCD touch panel at the center of the system (**Figure 7**). This panel is used to monitor, for example:

- 1) The status of the library and drives
- 2) The CAS operation (e.g., CAS door-open)
- 3) System errors (alarms)

The LT270 also displays a Web panel

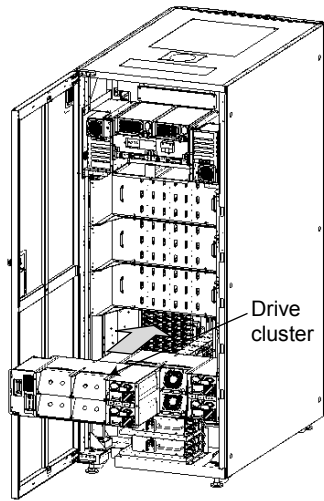

Figure 6  
Drive cluster mechanism.

(**Figure 8**) for remote maintenance during system failures via a LAN interface. This panel is used for:

- 1) Monitoring the status of the robots and drives
- 2) Collecting trace information about the robots and drives
- 3) Hot maintenance (removal and building-in of components)
- 4) System setup
- 5) Firmware uploading

For security, passwords can be set for the LCD panel and Web panel (e.g., for regular operators, system administrators, and maintenance personnel).

### 3.5 Hot maintenance

To ensure continuous operation, the system has the following hot-maintenance features:

- 1) Only the target cartridge mounting cell needs to be pulled out of the cabinet for hot cartridge replacement
- 2) The control printed circuit assembly (PCA) has hot-plug circuitry to enable hot removal and building-in of components over the Web.
- 3) A fixed WWN is assigned to each drive slot so drives can be hot-replaced without resetting the WWN.

Further details are given below.

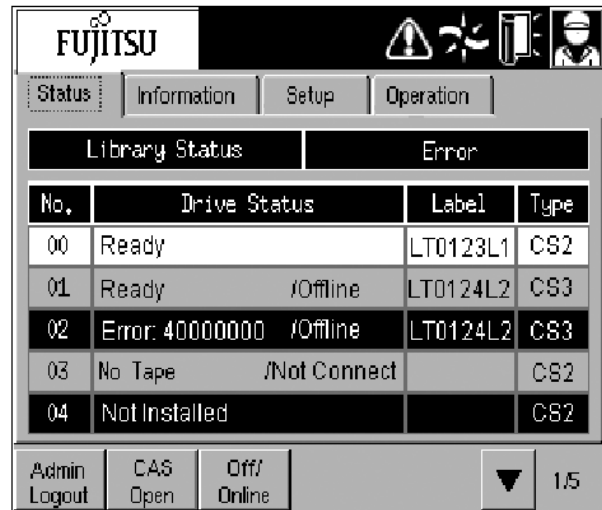

Figure 7  
LCD touch panel screen for operator/administrator.

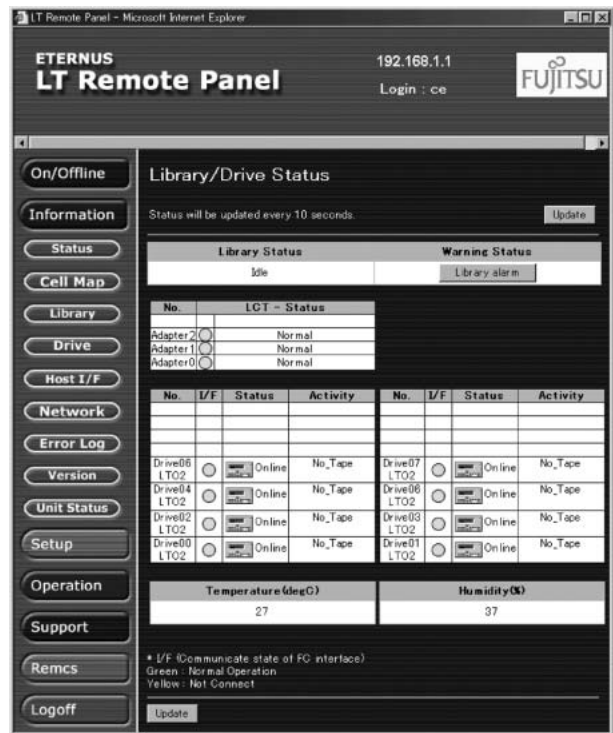

Figure 8  
Web panel screen.

- 1) Robot structure

Providing more space for maintenance work reduces the space available for cells. To solve this problem, maintenance work is done outside the cabinet by pulling out the robots (**Figure 9**).



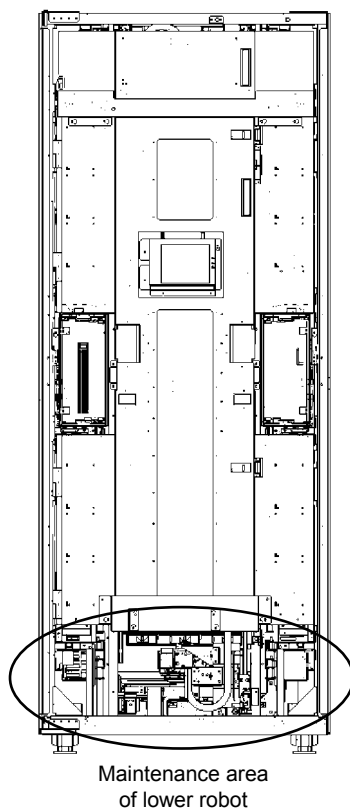

Figure 9  
Hot maintenance area of robot.

The robot mechanism consists of a robot unit having the major robot functions and a base for securing the unit. At maintenance time, the areas of the working robot and the robot to be maintained are separated by a partition to protect the operator from injury, and then the robot to be maintained is removed (**Figure 10**).

After maintenance work, the repaired robot performs self-diagnosis in the standby position. Then, if the robot does not detect a fault, it can be made the working robot or the standby robot without affecting operation.

The standby robot performs periodic self-diagnoses even if there are no problems.

## 2) Tape drives

The tape drives are also hot-replaceable. The main unit, power supply, PCB for relaying the robot interface, and cooling fans of each tape drive are integrated into a single module.

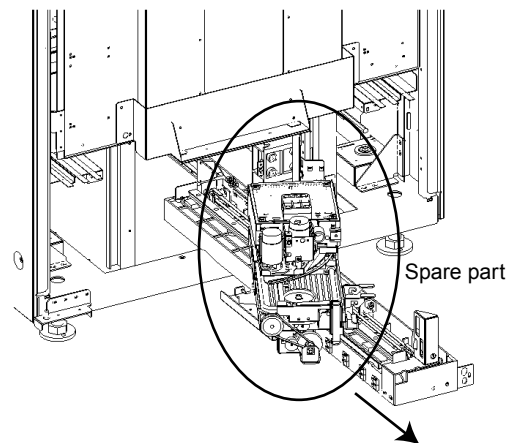

Figure 10  
Hot maintenance of robot.

The tape drives can be maintained inside their module unit. Drive modules can be removed from the system simply by disconnecting their cables from the system. New drive modules are connected to the power supply and library by inserting them into the system. The WWNs that the library allocates to the drives can be automatically built in to an ISV product without suspending operation of the LT270 and host.

## 3) Control PCBs

The control PCBs can be hot-replaced using the hot-swap feature from the Web panel (**Figure 11**).

## 3.6 System/media administration feature

The LT270 has a system/media administration feature for monitoring the status of the tape cartridges and the system.

### 1) Built-in temperature and humidity sensors

The storage environment for tape cartridges must be carefully controlled, especially the temperature and humidity. Therefore, the LT270 continuously monitors and reports the temperature and humidity inside the system.

### 2) Storage and administration of cartridge memory (CM) information in the system

Each cartridge contains a contactless CM chip that stores usage information about the cartridge, for example, its error information and

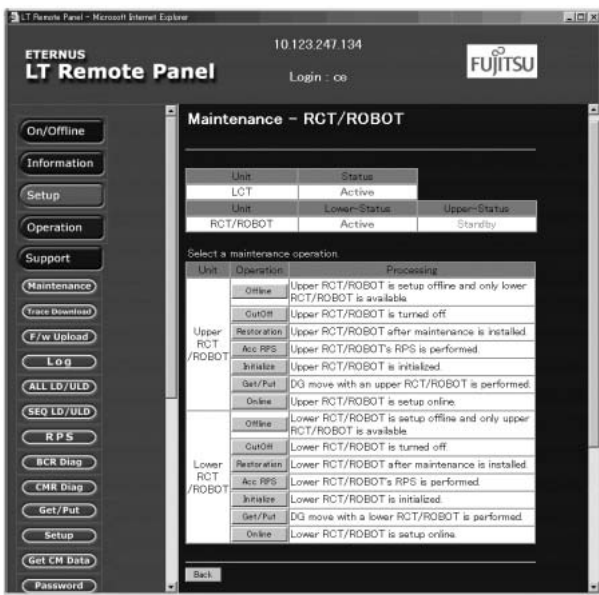

Figure 11 Web panel screen for hot replacement of control PCBs.

usage history. The LT270 uses this information to generate alarms when cartridges reach the end of their lives.

### 3) System status monitor

The system monitors the operation hours and number of cartridge accesses for each drive and robot and displays a message when a drive or robot is approaching the end of its life.

## 3.7 Robot downsizing

Robot downsizing was indispensable in order to realize robot redundancy and increase the cartridge storage volume, which are the main features of this system. These were achieved mainly by using small motors and downsizing the hand mechanism.

To use a small Y-motor, we had to reduce its mechanical load, and this was achieved by connecting a balancer as a counterweight. This also helped eliminate the need for a magnetic brake and various other components to prevent the robots from dropping down in the event their Y-axis driving mechanisms failed. Moreover, this made it easier to downsize the power supply and driving circuit.

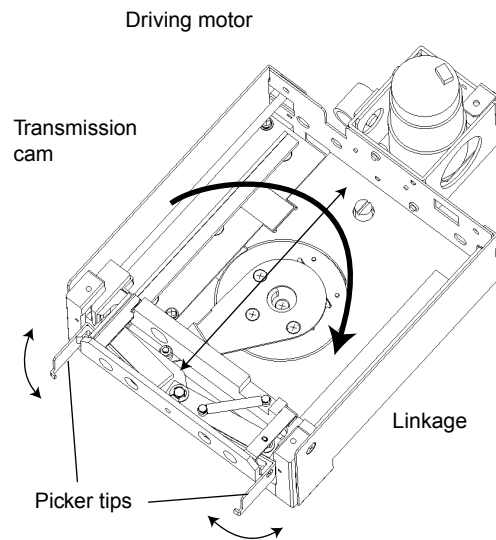

Figure 12 Hand mechanism.

Because the hand mechanism moves in three dimensions (vertically, back and forth, and right and left) it is important to minimize the amount of dead space; otherwise, the overall mounting efficiency of the library will deteriorate.

The hand mechanism is required to quickly and accurately insert and remove cartridges and eject them to the cartridge shelf or one of the drives.

To achieve this, the downsized hand has a single driving motor that directly moves the hand back and forth and indirectly opens and closes the picker tips via a transmission cam and linkage (Figure 12).

## 3.8 Development technologies

Before building an evaluation LT270 system, we did a thorough simulation of its technologies. The simulation greatly increased the development efficiency because it enabled us to confirm the LT270 unit's structure without a trial manufacture and also minimized the number of repairs and corrections.

The development technologies we used included the following:

1) Mechanical design review using a VPS (Virtual Product Simulator)

Visualizing the inside of the system before completing the design enabled us to review the design at an early stage with people other than the mechanical designers.

2) Proving the firmware using VPS-IOC (Virtual Product Simulator)

A quarter of the tests done before the system was finalized were completed by tuning the firmware.

3) Online review of LCD/Web panel

We tested the screen designs and operability using a modeling program on a PC; as a result, no problems occurred during the test phase.

## 4. Conclusion

The LT270 has the following unique features:

- Highly reliable redundant robots
- A dual robot controller
- Easy-to-add optional drives and cells
- Ultra-reliable data exchange and media management
- 709 cartridges in just a 0.99 m<sup>2</sup> footprint
- Hot swappable main components
- Auto-cleaning feature

To protect corporate and personal information from natural disasters such as earthquakes, tidal waves, and typhoons and from terrorism, data backup is indispensable. In addition, high-performance, large-capacity systems are needed to back up the ever-growing volume of users' data.

Disk-to-disk backup using disk snapshots is useful for minimizing downtime in online business operations, but it increases the backup cost and causes a high disk load. Moreover, because of the limited space of disks, there is a limit to the number of backup generations that can be made.

On the other hand, LTO backup offers high-speed, large-capacity, remote storage (storage outside of a center) at low cost. In addition, hybrid solutions are being developed that use low-cost-per-bit tapes at the back end for large-scale archive storage, virtual tape systems, and other applications.

The demand for large-capacity, high-quality library systems that use automated, low-cost tape devices is increasing. We firmly believe that the LT270 will contribute much to the industry as a backup system for large, open-system storage solutions.



**Yasuhiko Hanaoka** received the B.S. degree in Electronics from Nihon University, Tokyo, Japan in 1982. He joined Fujitsu Ltd., Kawasaki, Japan in 1982, where he has been developing tape library systems. Since 1997, he has also been developing magnetic tape controllers.



**Akira Takano** graduated from Toin Technical College, Yokohama, Japan in 1986. He joined Fujitsu Ltd., Kawasaki, Japan in 1989, where he has been developing magnetic tape devices. Since 1998, he has also been developing mechanisms for tape libraries.



**Makoto Sasaki** graduated from the Department of Mechanical Engineering at Toyama National College of Technology, Toyama, Japan in 1986. He joined Fujitsu Ltd. in 1986, where he has been developing magnetic tape drives. Since 2000, he has also been developing tape library systems.