



About RosettaNet solution

Fujitsu Ltd.



RosettaNet solution system

RosettaNet solution has 3 phases:

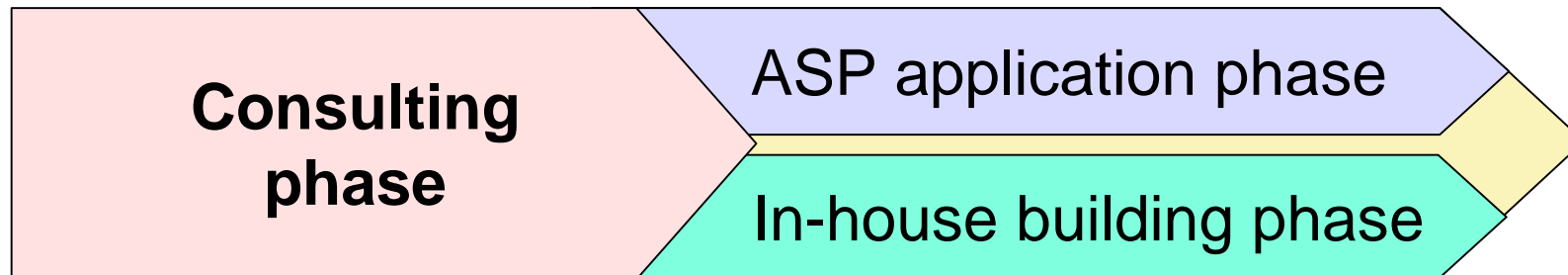

Consulting phase

*The consulting phase utilizes our know-how of RosettaNet implementation in our purchasing department

ASP application phase

* With ASP, knowledge of complex RNIF and setting/maintenance of B2B server are no longer necessary.

* Services are provided 24 hours a day, 365 days a year, with a monthly maintenance period.

In-house building

* Support building, testing, and administering the RosettaNet server using our product, INTERSTAGE CollaborationRing

Example of building RosettaNet system

1. ASP

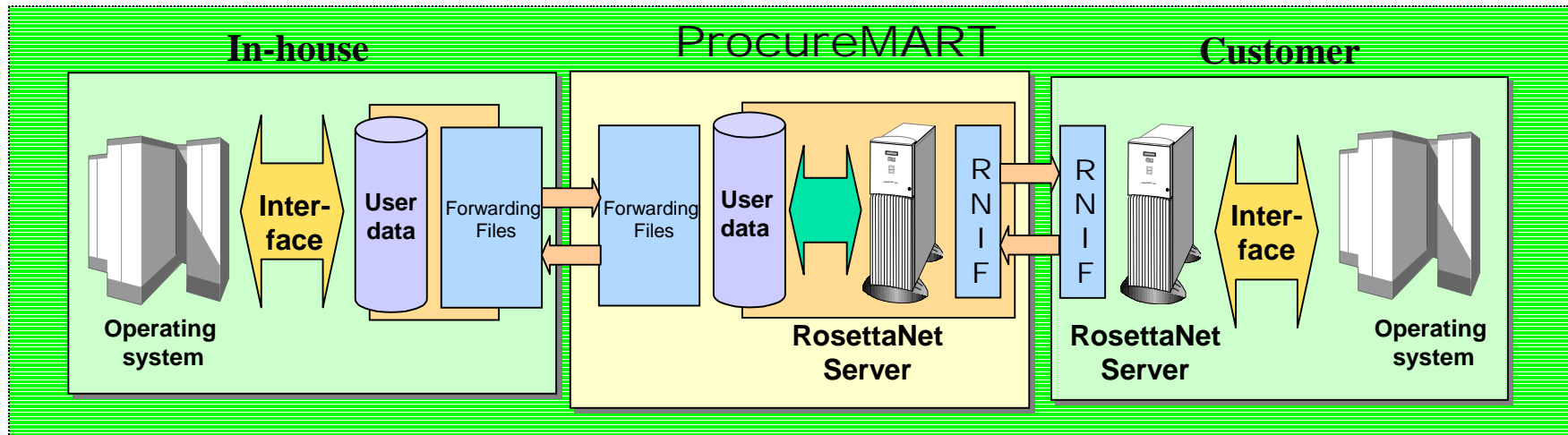

2. In-house building

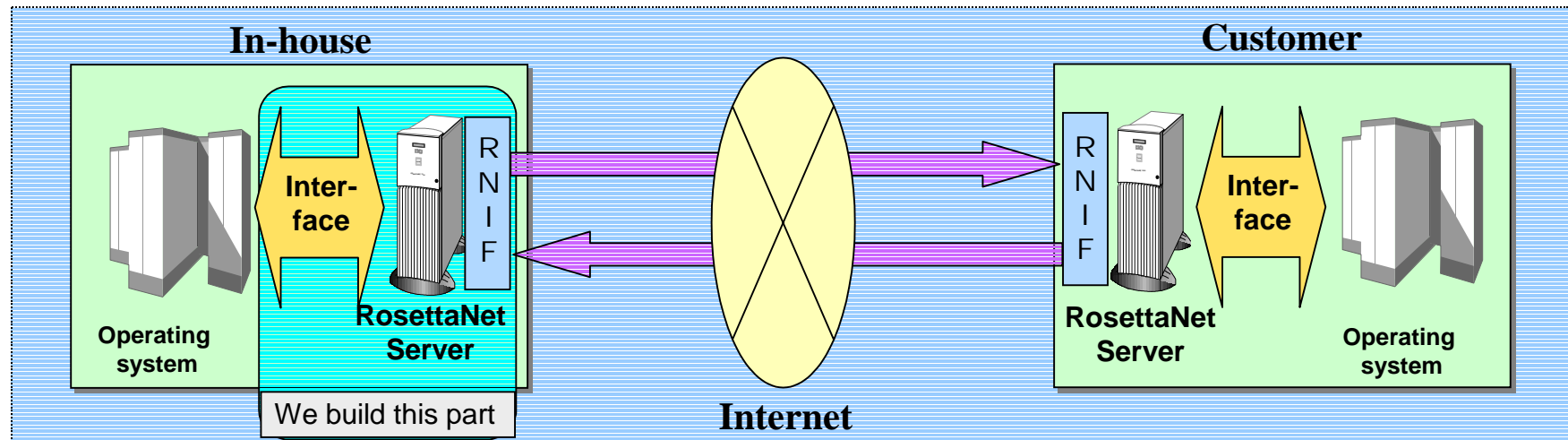

RosettaNet consulting

We offer the following operation terms (samples) as a service menu in the consulting phase until the actual implementation.

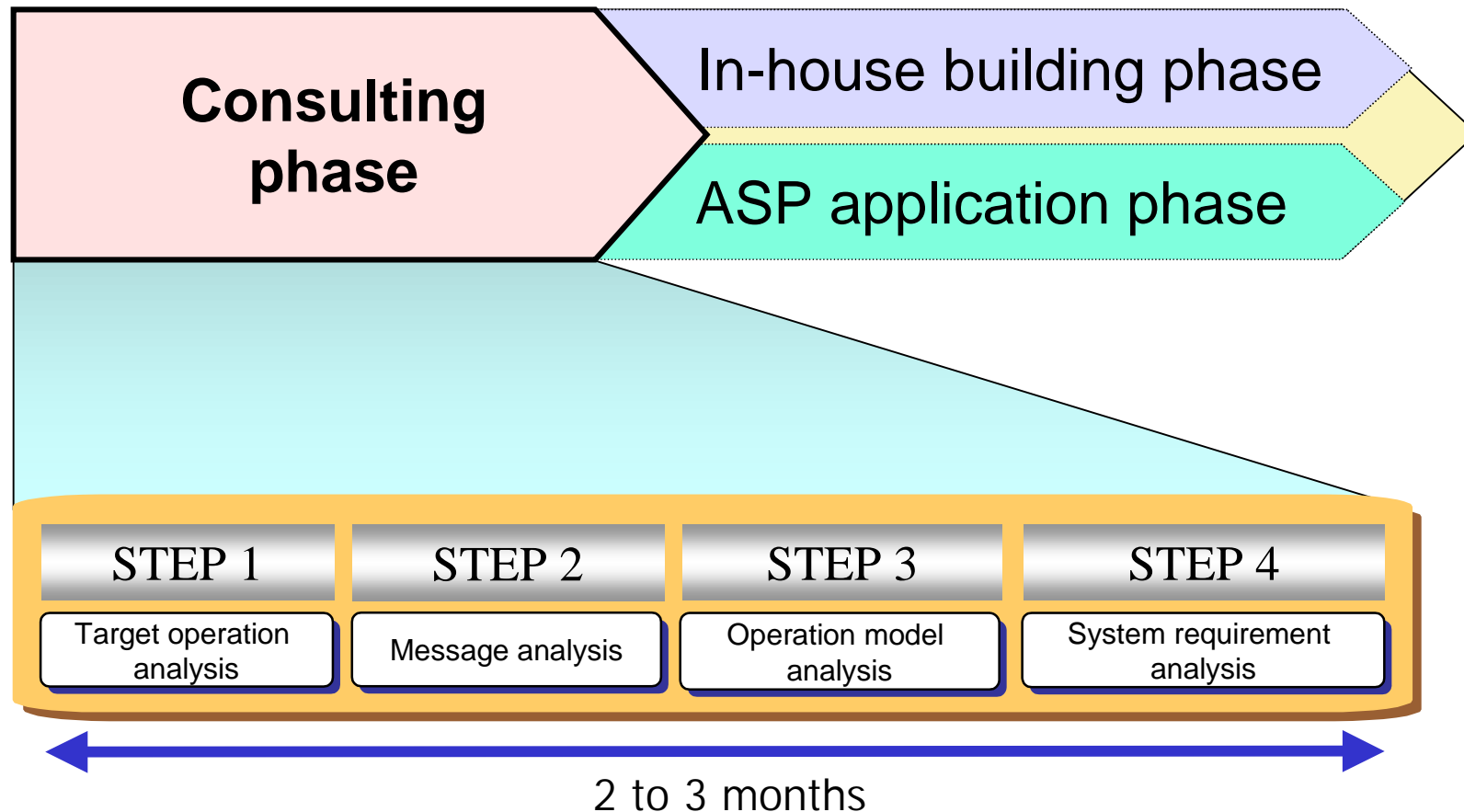

RosettaNet ASP services

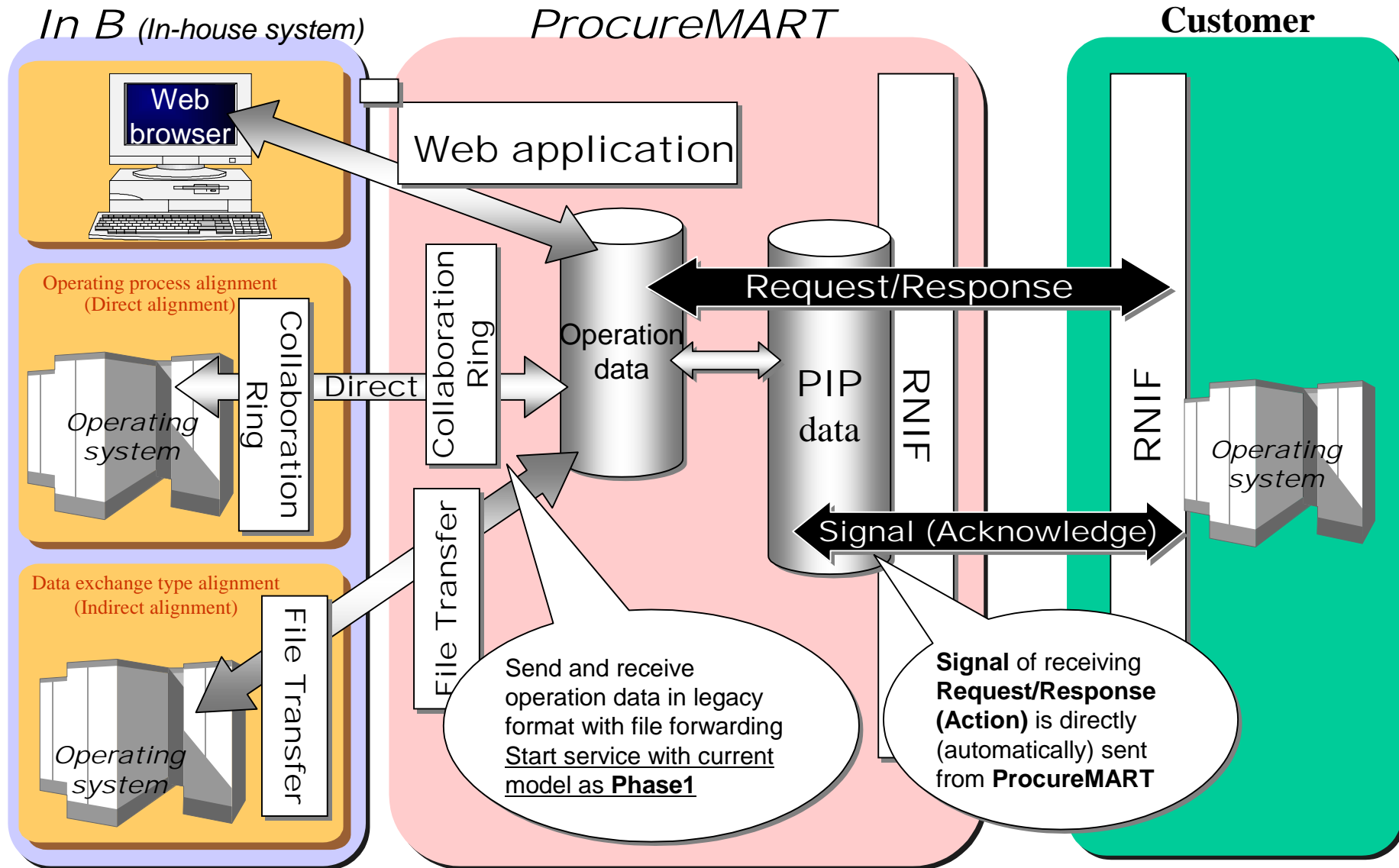

Example of in-house building

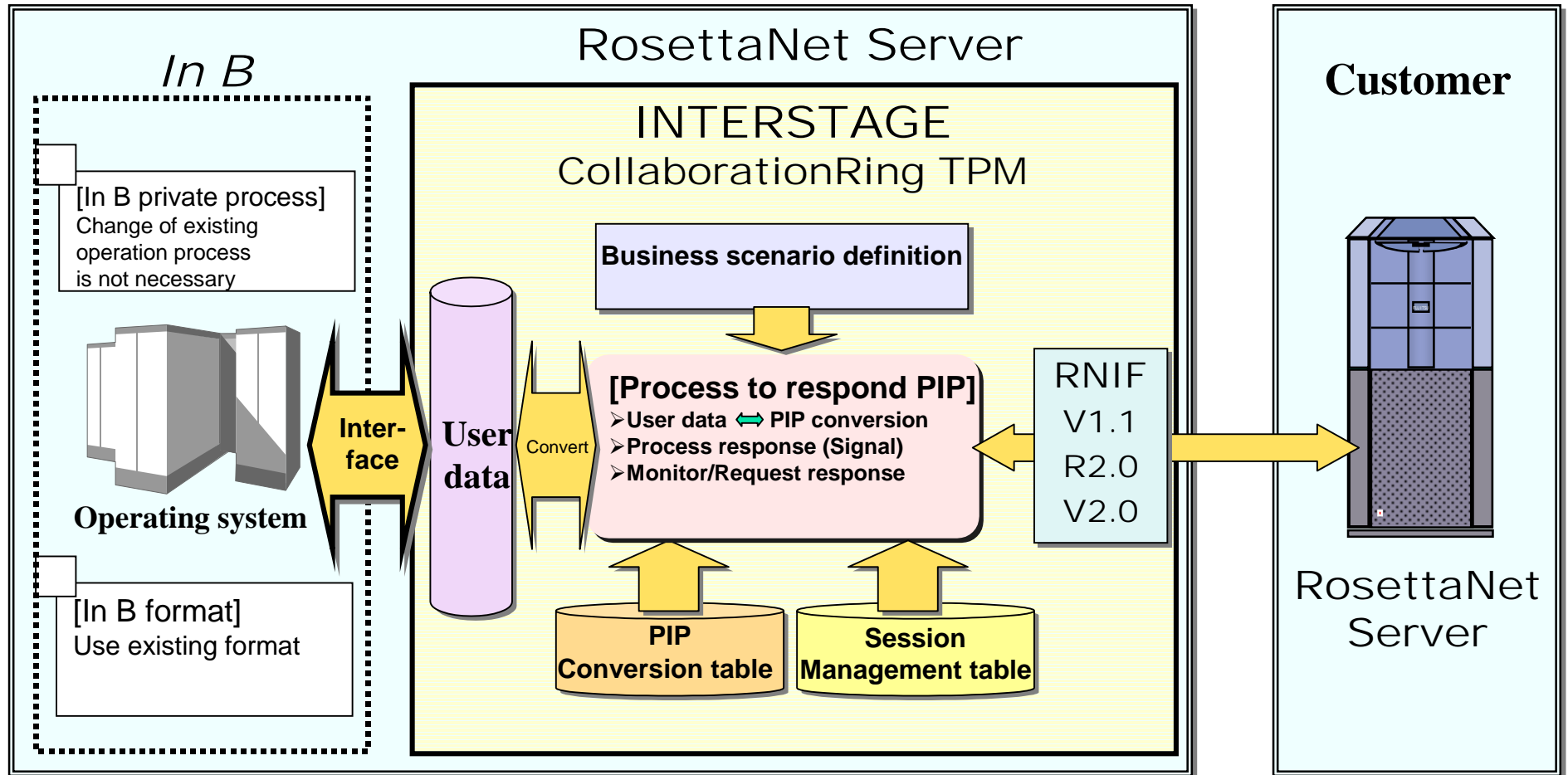

We build the “RosettaNet Server”
and the “operating system interface”.