

# **SPARC Enterprise M3000 Server**

## **Site Planning Guide**



**ORACLE**

**SPARC**

Part No.: E23585-02  
Manual Code: C120-H030-06EN  
March 2012

Copyright © 2008, 2012, Fujitsu Limited. All rights reserved.

Oracle and/or its affiliates provided technical input and review on portions of this material.

Oracle and/or its affiliates and Fujitsu Limited each own or control intellectual property rights relating to products and technology described in this document, and such products, technology and this document are protected by copyright laws, patents, and other intellectual property laws and international treaties.

This document and the product and technology to which it pertains are distributed under licenses restricting their use, copying, distribution, and decompilation. No part of such product or technology, or of this document, may be reproduced in any form by any means without prior written authorization of Oracle and/or its affiliates and Fujitsu Limited, and their applicable licensors, if any. The furnishings of this document to you does not give you any rights or licenses, express or implied, with respect to the product or technology to which it pertains, and this document does not contain or represent any commitment of any kind on the part of Oracle or Fujitsu Limited, or any affiliate of either of them.

This document and the product and technology described in this document may incorporate third-party intellectual property copyrighted by and/or licensed from the suppliers to Oracle and/or its affiliates and Fujitsu Limited, including software and font technology.

Per the terms of the GPL or LGPL, a copy of the source code governed by the GPL or LGPL, as applicable, is available upon request by the End User. Please contact Oracle and/or its affiliates or Fujitsu Limited.

This distribution may include materials developed by third parties.

Parts of the product may be derived from Berkeley BSD systems, licensed from the University of California. UNIX is a registered trademark in the U.S. and in other countries, exclusively licensed through X/Open Company, Ltd.

Oracle and Java are registered trademarks of Oracle and/or its affiliates. Fujitsu and the Fujitsu logo are registered trademarks of Fujitsu Limited.

All SPARC trademarks are used under license and are registered trademarks of SPARC International, Inc. in the U.S. and other countries. Products bearing SPARC trademarks are based upon architectures developed by Oracle and/or its affiliates. SPARC64 is a trademark of SPARC International, Inc., used under license by Fujitsu Microelectronics, Inc. and Fujitsu Limited. Other names may be trademarks of their respective owners.

United States Government Rights - Commercial use. U.S. Government users are subject to the standard government user license agreements of Oracle and/or its affiliates and Fujitsu Limited and the applicable provisions of the FAR and its supplements.

Disclaimer: The only warranties granted by Oracle and Fujitsu Limited, and/or any affiliate of either of them in connection with this document or any product or technology described herein are those expressly set forth in the license agreement pursuant to which the product or technology is provided. EXCEPT AS EXPRESSLY SET FORTH IN SUCH AGREEMENT, ORACLE OR FUJITSU LIMITED, AND/OR THEIR AFFILIATES MAKE NO REPRESENTATIONS OR WARRANTIES OF ANY KIND (EXPRESS OR IMPLIED) REGARDING SUCH PRODUCT OR TECHNOLOGY OR THIS DOCUMENT, WHICH ARE ALL PROVIDED AS IS, AND ALL EXPRESS OR IMPLIED CONDITIONS, REPRESENTATIONS AND WARRANTIES, INCLUDING WITHOUT LIMITATION ANY IMPLIED WARRANTY OF MERCHANTABILITY, FITNESS FOR A PARTICULAR PURPOSE OR NON-INFRINGEMENT, ARE DISCLAIMED, EXCEPT TO THE EXTENT THAT SUCH DISCLAIMERS ARE HELD TO BE LEGALLY INVALID. Unless otherwise expressly set forth in such agreement, to the extent allowed by applicable law, in no event shall Oracle or Fujitsu Limited, and/or any of their affiliates have any liability to any third party under any legal theory for any loss of revenues or profits, loss of use or data, or business interruptions, or for any indirect, special, incidental or consequential damages, even if advised of the possibility of such damages.

DOCUMENTATION IS PROVIDED "AS IS" AND ALL EXPRESS OR IMPLIED CONDITIONS, REPRESENTATIONS AND WARRANTIES, INCLUDING ANY IMPLIED WARRANTY OF MERCHANTABILITY, FITNESS FOR A PARTICULAR PURPOSE OR NON-INFRINGEMENT, ARE DISCLAIMED, EXCEPT TO THE EXTENT THAT SUCH DISCLAIMERS ARE HELD TO BE LEGALLY INVALID.



Copyright © 2008, 2012, Fujitsu Limited. Tous droits réservés.

Oracle et/ou ses sociétés affiliées ont fourni et vérifié des données techniques de certaines parties de ce composant.

Oracle et/ou ses sociétés affiliées et Fujitsu Limited détiennent et contrôlent chacune des droits de propriété intellectuelle relatifs aux produits et technologies décrits dans ce document. De même, ces produits, technologies et ce document sont protégés par des lois sur le copyright, des brevets, d'autres lois sur la propriété intellectuelle et des traités internationaux.

Ce document, le produit et les technologies afférents sont exclusivement distribués avec des licences qui en restreignent l'utilisation, la copie, la distribution et la décompilation. Aucune partie de ce produit, de ces technologies ou de ce document ne peut être reproduite sous quelque forme que ce soit, par quelque moyen que ce soit, sans l'autorisation écrite préalable d'Oracle et/ou ses sociétés affiliées et de Fujitsu Limited, et de leurs éventuels bailleurs de licence. Ce document, bien qu'il vous ait été fourni, ne vous confère aucun droit et aucune licence, expresses ou tacites, concernant le produit ou la technologie auxquels il se rapporte. Par ailleurs, il ne contient ni ne représente aucun engagement, de quelque type que ce soit, de la part d'Oracle ou de Fujitsu Limited, ou des sociétés affiliées de l'une ou l'autre entité.

Ce document, ainsi que les produits et technologies qu'il décrit, peuvent inclure des droits de propriété intellectuelle de parties tierces protégés par copyright et/ou cédés sous licence par des fournisseurs à Oracle et/ou ses sociétés affiliées et Fujitsu Limited, y compris des logiciels et des technologies relatives aux polices de caractères.

Conformément aux conditions de la licence GPL ou LGPL, une copie du code source régi par la licence GPL ou LGPL, selon le cas, est disponible sur demande par l'utilisateur final. Veuillez contacter Oracle et/ou ses sociétés affiliées ou Fujitsu Limited.

Cette distribution peut comprendre des composants développés par des parties tierces.

Des parties de ce produit peuvent être dérivées des systèmes Berkeley BSD, distribués sous licence par l'Université de Californie. UNIX est une marque déposée aux États-Unis et dans d'autres pays, distribuée exclusivement sous licence par X/Open Company, Ltd.

Oracle et Java sont des marques déposées d'Oracle Corporation et/ou de ses sociétés affiliées. Fujitsu et le logo Fujitsu sont des marques déposées de Fujitsu Limited.

Toutes les marques SPARC sont utilisées sous licence et sont des marques déposées de SPARC International, Inc., aux États-Unis et dans d'autres pays. Les produits portant la marque SPARC reposent sur des architectures développées par Oracle et/ou ses sociétés affiliées. SPARC64 est une marque de SPARC International, Inc., utilisée sous licence par Fujitsu Microelectronics, Inc. et Fujitsu Limited. Tout autre nom mentionné peut correspondre à des marques appartenant à d'autres propriétaires.

United States Government Rights - Commercial use. U.S. Government users are subject to the standard government user license agreements of Oracle and/or its affiliates and Fujitsu Limited and the applicable provisions of the FAR and its supplements.

Avis de non-responsabilité : les seules garanties octroyées par Oracle et Fujitsu Limited et/ou toute société affiliée de l'une ou l'autre entité en rapport avec ce document ou tout produit ou toute technologie décrits dans les présentes correspondent aux garanties expressément stipulées dans le contrat de licence régissant le produit ou la technologie fournis. SAUF MENTION CONTRAIRE EXPRESSÉMENT STIPULÉE DANS CE CONTRAT, ORACLE OU FUJITSU LIMITED ET LES SOCIÉTÉS AFFILIÉES À L'UNE OU L'AUTRE ENTITÉ REJETTENT TOUTE REPRÉSENTATION OU TOUTE GARANTIE, QUELLE QU'EN SOIT LA NATURE (EXPRESSE OU IMPLICITE) CONCERNANT CE PRODUIT, CETTE TECHNOLOGIE OU CE DOCUMENT, LESQUELS SONT FOURNIS EN L'ÉTAT. EN OUTRE, TOUTES LES CONDITIONS, REPRÉSENTATIONS ET GARANTIES EXPRESSES OU TACITES, Y COMPRIS NOTAMMENT TOUTE GARANTIE IMPLICITE RELATIVE À LA QUALITÉ MARCHANDE, À L'APTITUDE À UNE UTILISATION PARTICULIÈRE OU À L'ABSENCE DE CONTREFAÇON, SONT EXCLUES, DANS LA MESURE AUTORISÉE PAR LA LOI APPLICABLE. Sauf mention contraire expressément stipulée dans ce contrat, dans la mesure autorisée par la loi applicable, en aucun cas Oracle ou Fujitsu Limited et/ou l'une ou l'autre de leurs sociétés affiliées ne sauraient être tenues responsables envers une quelconque partie tierce, sous quelque théorie juridique que ce soit, de tout manque à gagner ou de perte de profit, de problèmes d'utilisation ou de perte de données, ou d'interruptions d'activités, ou de tout dommage indirect, spécial, secondaire ou consécutif, même si ces entités ont été préalablement informées d'une telle éventualité.

LA DOCUMENTATION EST FOURNIE « EN L'ÉTAT » ET TOUTE AUTRE CONDITION, DÉCLARATION ET GARANTIE, EXPRESSE OU TACITE, EST FORMELLEMENT EXCLUE, DANS LA MESURE AUTORISÉE PAR LA LOI EN VIGUEUR, Y COMPRIS NOTAMMENT TOUTE GARANTIE IMPLICITE RELATIVE À LA QUALITÉ MARCHANDE, À L'APTITUDE À UNE UTILISATION PARTICULIÈRE OU À L'ABSENCE DE CONTREFAÇON.



# Contents

---

**Preface** vii

- 1. Before Setting Up the Server** 1-1
- 2. Server Specifications** 2-1
  - 2.1 Server Components 2-1
  - 2.2 Server Installation Guidelines 2-3
    - 2.2.1 Service Clearance 2-3
    - 2.2.2 Space for Thermal Clearance 2-5
- 3. Environmental and Electrical Specifications** 3-1
  - 3.1 Environmental Requirements 3-1
    - 3.1.1 Ambient Temperature 3-2
    - 3.1.2 Ambient Relative Humidity 3-3
    - 3.1.3 Contamination Specifications 3-3
  - 3.2 Cooling Specifications 3-4
    - 3.2.1 Airflow Indicator 3-5
  - 3.3 Power Requirements 3-6
    - 3.3.1 Electrical Specifications 3-6
    - 3.3.2 Power Cord Specifications 3-7
    - 3.3.3 Power Supply Facility 3-7

3.3.4 Grounding 3-8

3.3.5 Power Consumption Monitoring Function 3-8

**4. Network Connection 4-1**

4.1 Setup and Network Connection 4-1

4.2 Platform and Domain Setup Information 4-2

4.3 Choosing the System Control Network Configuration 4-3

**A. UPS Controller A-1**

A.1 Overview A-1

A.2 Signal Cables A-2

A.3 Signal Line Configuration A-2

A.4 Cable Connector A-4

**B. DC Power Supply Model B-1**

B.1 Server Installation Guidelines B-1

B.2 Cooling Specifications B-2

B.3 Power Requirements B-4

B.3.1 Electrical Specifications B-4

B.3.2 Power Cord Specifications B-5

B.3.3 Power Supply Facility B-6

B.3.4 Grounding B-7

B.3.5 Power Consumption Monitoring Function B-8

**Index Index-1**

# Preface

---

This guide describes the physical, environmental, and electrical specification requirements for the SPARC Enterprise M3000 Server from Oracle and Fujitsu.

Due to the amount of time required to plan and properly prepare a site for installation of the server, you must fulfill all of the requirements outlined in this manual before your equipment arrives. References herein to the M3000 server are reference to the SPARC Enterprise M3000 server.

This preface includes the following sections:

- [“Audience” on page vii](#)
- [“Related Documentation” on page viii](#)
- [“Text Conventions” on page ix](#)
- [“Notes on Safety” on page ix](#)
- [“Syntax of the Command-Line Interface \(CLI\)” on page x](#)
- [“Documentation Feedback” on page x](#)

---

## Audience

This guide is written for experienced system administrators with working knowledge of computer networks and advanced knowledge of the Oracle Solaris Operating System (Oracle Solaris OS).

---

# Related Documentation

All documents for your server are available online at the following locations.

---

Documentation	Link
Sun Oracle software-related manuals (Oracle Solaris OS, and so on)	<a href="http://www.oracle.com/documentation">http://www.oracle.com/documentation</a>
Fujitsu documents	<a href="http://www.fujitsu.com/sparcenterprise/manual/">http://www.fujitsu.com/sparcenterprise/manual/</a>
Oracle M-series server documents	<a href="http://www.oracle.com/technetwork/documentation/sparc-mseries-servers-252709.html">http://www.oracle.com/technetwork/documentation/sparc-mseries-servers-252709.html</a>

---

The following table lists titles of related documents.

---

Related SPARC Enterprise M3000 Server Documents
<i>SPARC Enterprise M3000 Server Site Planning Guide</i>
<i>SPARC Enterprise Equipment Rack Mounting Guide</i>
<i>SPARC Enterprise M3000 Server Getting Started Guide*</i>
<i>SPARC Enterprise M3000 Server Overview Guide</i>
<i>SPARC Enterprise M3000/M4000/M5000/M8000/M9000 Servers Important Legal and Safety Information *</i>
<i>SPARC Enterprise M3000 Server Safety and Compliance Guide</i>
<i>SPARC Enterprise M3000 Server Installation Guide</i>
<i>SPARC Enterprise M3000 Server Service Manual</i>
<i>SPARC Enterprise M3000/M4000/M5000/M8000/M9000 Servers Administration Guide</i>
<i>SPARC Enterprise M3000/M4000/M5000/M8000/M9000 Servers XSCF User's Guide</i>
<i>SPARC Enterprise M3000/M4000/M5000/M8000/M9000 Servers XSCF Reference Manual</i>
<i>SPARC Enterprise M3000/M4000/M5000/M8000/M9000 Servers Product Notes†</i>
<i>SPARC Enterprise M3000 Server Product Notes</i>
<i>SPARC Enterprise M3000/M4000/M5000/M8000/M9000 Servers Glossary</i>

---

\* This is a printed document.

† Beginning with the XCP 1100 release.



---

# Text Conventions

This manual uses the following fonts and symbols to express specific types of information.

Font/Symbol	Meaning	Example
<b>AaBbCc123</b>	What you type, when contrasted with on-screen computer output. This font represents the example of command input in the frame.	XSCF> <b>adduser jsmith</b>
AaBbCc123	The names of commands, files, and directories; on-screen computer output. This font represents the example of command output in the frame.	XSCF> <b>showuser -P</b> User Name: jsmith Privileges: useradm auditadm
<i>Italic</i>	Indicates the name of a reference manual, a variable, or user-replaceable text.	See the <i>SPARC Enterprise M3000/M4000/M5000/M8000/M9000 Servers XSCF User's Guide</i> .
" "	Indicates names of chapters, sections, items, buttons, or menus.	See Chapter 2, "System Features."

---

# Notes on Safety

Read the following documents thoroughly before using or handling any SPARC Enterprise M3000 server:

- *SPARC Enterprise M3000/M4000/M5000/M8000/M9000 Servers Important Legal and Safety Information*
- *SPARC Enterprise M3000 Server Safety and Compliance Guide*

---

# Syntax of the Command-Line Interface (CLI)

The command syntax is as follows:

- A variable that requires input of a value must be put in *Italics*.
- An optional element must be enclosed in [].
- A group of options for an optional keyword must be enclosed in [] and delimited by |.

---

## Documentation Feedback

If you have any comments or requests regarding this document, go to the following websites:

- For Oracle users:

<http://www.oracle.com/goto/docfeedback>

Include the title and part number of your document with your feedback:

*SPARC Enterprise M3000 Server Site Planning Guide*, part number E23585-02

- For Fujitsu users:

[http://www.fujitsu.com/global/contact/computing/sparce\\_index.html](http://www.fujitsu.com/global/contact/computing/sparce_index.html)

# Before Setting Up the Server

This chapter explains the items that must be confirmed before installation of the SPARC Enterprise M3000 server.

Prior to server installation, confirm that the requirements in [TABLE 1-1](#) have been met.

**TABLE 1-1** Preinstallation Requirements

	Check item	Check
<b>Server configuration</b>	• Has the configuration of the server been determined?	
	• Has the total number of servers been determined?	
<b>Training</b>	• Have the system administrator and operators taken the necessary training courses?	
<b>Environment</b>	• Does the computer room environment meet the temperature and humidity specifications? (see <a href="#">Section 3.1, “Environmental Requirements” on page 3-1</a> )	
	• Can the computer room environmental conditions be maintained and managed satisfactorily?	
	• Have appropriate security measures been taken for the computer room?	
	• Does the computer room have satisfactory fire control equipment in it?	
<b>Facility power</b>	• Have you confirmed the voltage for the equipment racks in which the server and peripheral devices are mounted?	
	• Has an adequate power supply facility been prepared for the server, monitors, and peripheral devices? (see <a href="#">Section 3.3, “Power Requirements” on page 3-6</a> )	
	• Is the power supply facility within 3.5 m (11.5 ft) of the equipment rack?	

**TABLE 1-1** Preinstallation Requirements (*Continued*)

<b>Check item</b>	<b>Check</b>
<b>Physical specifications</b>	
• Have the server installation locations been determined?	
• Does the server layout meet the service clearance requirements of the server? (see <a href="#">Section 2.2.1, "Service Clearance" on page 2-3</a> )	
• Does the server layout preclude exhaust air from any device entering the air inlet of the server?	
<b>Network specifications</b>	
• Have you obtained the necessary information for your network connections? (see <a href="#">Section 4.2, "Platform and Domain Setup Information" on page 4-2</a> )	

# Server Specifications

---

This chapter explains the physical specifications of the M3000 server, including external dimensions, space requirements, and limitations.

- [Section 2.1, “Server Components” on page 2-1](#)
- [Section 2.2, “Server Installation Guidelines” on page 2-3](#)

---

## 2.1 Server Components

The M3000 server has been designed to be mounted in qualified equipment racks. For details of the mounting requirements, see the *SPARC Enterprise Equipment Rack Mounting Guide*.

FIGURE 2-1 shows external views of the M3000 server.

FIGURE 2-1 Front and Rear Views of the Server

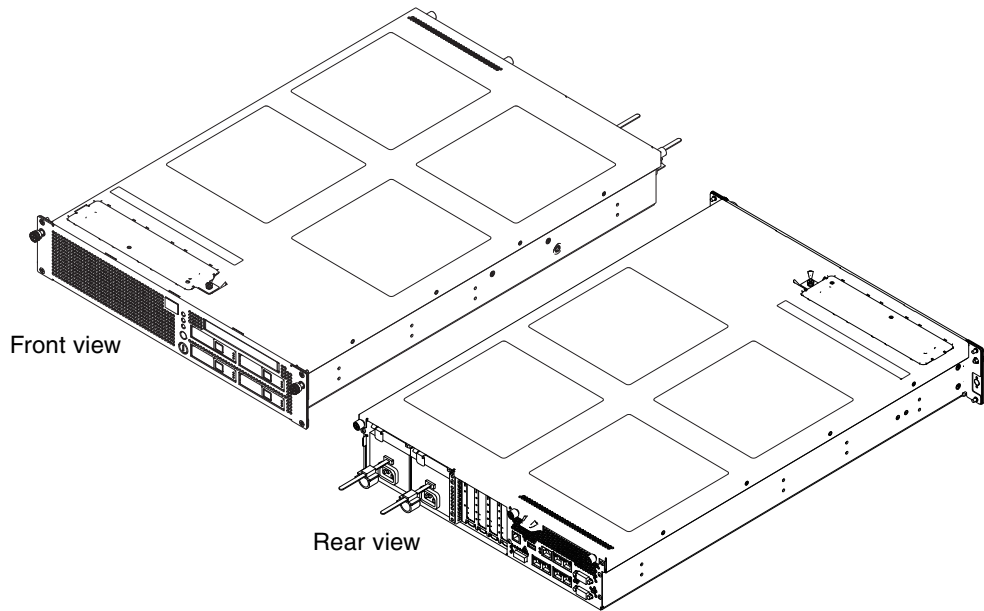

TABLE 2-1 lists the maximum configurations of the M3000 server.

TABLE 2-1 Components

Component	Maximum Number per Server
Motherboard unit	1
Memory module	8
PCI Express (PCIe) card	4
Hard disk drive	4
Hard disk drive backplane	1
CD-RW/DVD-RW drive unit	1
Power supply unit	2
Fan unit	2
Fan backplane	1
Operator panel	1

---

## 2.2 Server Installation Guidelines

As you plan the installation of the M3000 server mounted in an equipment rack, keep the following conditions in mind:

- Each server requires two power cords. Each power cord must be connected to a separate input power source. When using the dual power feed option, the power cords must be connected to separate power supply facilities.
- The power supply facility must meet the relevant electrical codes.

For details of the electrical requirements, see [Section 3.3, “Power Requirements” on page 3-6.](#)

For details of the server installation, see the *SPARC Enterprise M3000 Server Installation Guide*.

### 2.2.1 Service Clearance

The service clearance depends on the requirements for the rack used. For accurate service clearance measurements, see the *SPARC Enterprise Equipment Rack Mounting Guide*.

[FIGURE 2-2](#) shows an example of the service clearance for the M3000 server mounted in a qualified equipment rack.

**FIGURE 2-2** Example of the Service Clearance at the Front and Rear of Equipment Racks (Top View)

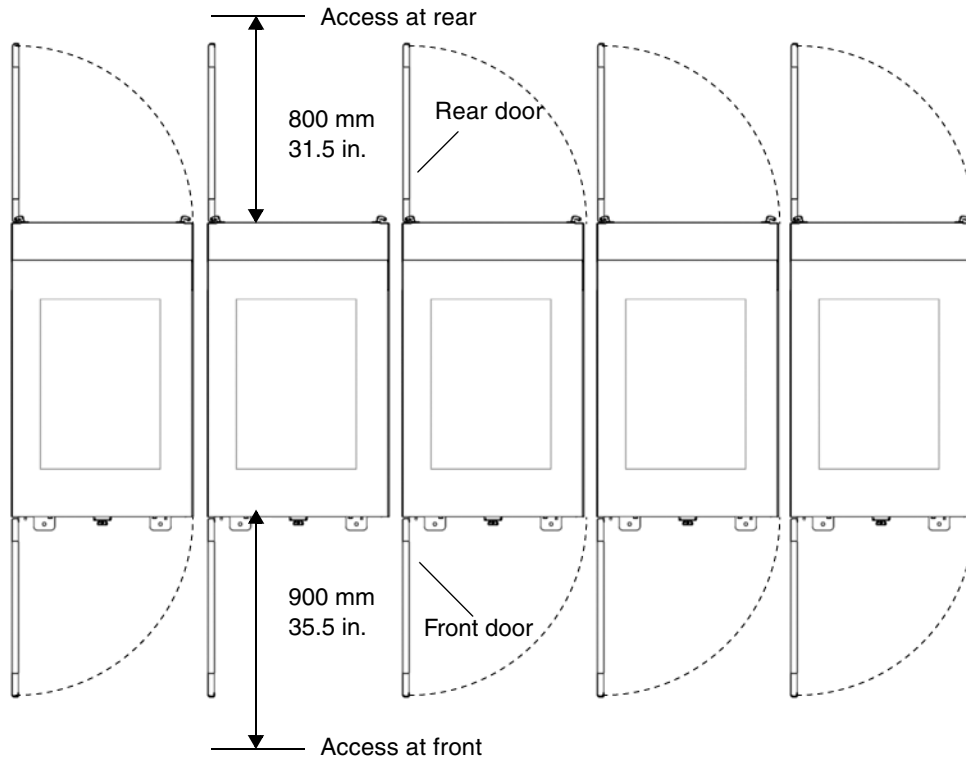

[TABLE 2-2](#) lists physical specifications of the M3000 server.

**TABLE 2-2** Physical Specifications

Item	Specification	
	Container Box	Server
Height	289 mm/11.4 in.	87 mm/3.4 in.
Width	620 mm/24.4 in.	440 mm/17.4 in.
Depth	853 mm/33.6 in.	657 mm/25.9 in.
Weight	30 kg/66 lb	22 kg/48.5 lb*

\* The weight of cables are not included.



FIGURE 2-3 shows the external dimensions of the M3000 server container box.

FIGURE 2-3 Server Container Box

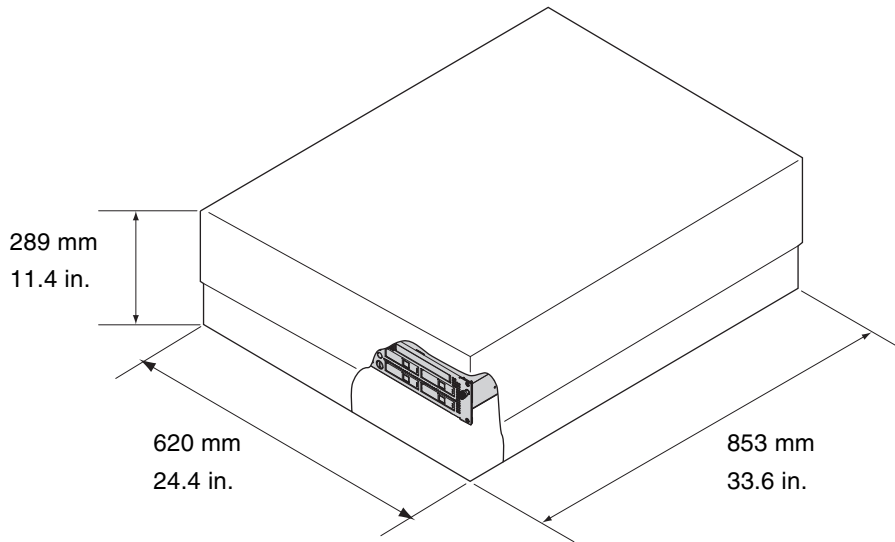

## 2.2.2 Space for Thermal Clearance

The M3000 server mounted in an equipment rack must have the necessary thermal distance maintained between the rear of the server and any obstacles or walls. For thermal clearance requirements, see the *SPARC Enterprise Equipment Rack Mounting Guide*.



# Environmental and Electrical Specifications

---

This chapter explains the environmental and electrical requirements necessary for stable operation of the M3000 server.

- [Section 3.1, “Environmental Requirements” on page 3-1](#)
- [Section 3.2, “Cooling Specifications” on page 3-4](#)
- [Section 3.3, “Power Requirements” on page 3-6](#)

---

## 3.1 Environmental Requirements

The M3000 server can be installed at a site that meets the environmental requirements described in [TABLE 3-1](#).

---

**Note** – The design of your environmental control system—such as computer room air-conditioning units—must ensure that intake air to the server complies with the limits specified in this section.

---

The environmental requirements listed in [TABLE 3-1](#) reflect the test results of the server. The optimum conditions indicate the recommended operating environment. Operating the server for extended periods at or near the operating range limits or installing the server in an environment where it remains at or near the non-operating range limits could possibly increase the failure rate of hardware components significantly. In order to minimize the occurrence of system failure due to component failure, set temperature and humidity in the optimal ranges.

To prevent overheating, the following requirements must be met:

- Protect against any warm air directed toward the front of the equipment rack.
- Protect against any warm air directed toward the front panel on the server.

**TABLE 3-1** Environmental Requirements

	Operating Range	Non-Operating Range	Optimum
Ambient temperature	5°C to 35°C (41°F to 95°F)	Unpacked: 0°C to 50°C (32°F to 122°F) Packed: -20°C to 60°C (-4°F to 140°F)	21°C to 23°C (70°F to 74°F)
Relative humidity *	20% RH to 80% RH	to 93% RH	45% RH to 50% RH
Altitude restriction †	3,000 m (10,000 ft)	12,000 m (40,000 ft)	
Temperature conditions	5°C to 35°C (41°F to 95°F) 0 m to 500 m (0 ft to 1,640 ft)		
	5°C to 33°C (41°F to 91.4°F) 501 m to 1,000 m (1,644 ft to 3,281 ft)		
	5°C to 31°C (41°F to 87.8°F) 1,001 m to 1,500 m (3,284 ft to 4,921 ft)		
	5°C to 29°C (41°F to 84.2°F) 1,501 m to 3,000 m (4,925 ft to 9,843 ft)		

\* There is no condensation regardless of the temperature and humidity.

† All altitudes are above sea level.

## 3.1.1 Ambient Temperature

The ambient temperature range of 21°C to 23°C (70°F to 74°F) is optimal for server reliability and operator comfort levels. It is easier to maintain safe associated relative humidity levels at this temperature range. Operating in this temperature range provides a safety buffer in the event the air conditioning systems go down for a period of time.

## 3.1.2 Ambient Relative Humidity

Ambient relative humidity levels between 45 percent and 50 percent are the most suitable for safe data processing operations. The reasons for this are as follows:

- The optimal range helps protect computer systems from corrosion problems associated with high humidity levels.
- The optimal range provides an operating time buffer in the event of an air conditioner control failure.
- The optimal range helps prevent failures or temporary malfunctions caused by the intermittent interference from the electrostatic discharge that may occur when the relative humidity is too low.

Electrostatic discharge is easily generated and less easily dissipated in areas where the relative humidity is below 35 percent. Electrostatic discharge becomes a critical issue when the humidity level drops below 30 percent. Compared to the guidelines used for typical office environments where room environment conditions are loosely controlled, the optimal relative humidity range is set for tighter control. However, this is not a difficult condition to meet for a server installed in a computer room, because a computer room normally has a high efficiency vapor barrier and low rate of air exchange.

## 3.1.3 Contamination Specifications

The allowable contaminations in the M3000 server are listed in [TABLE 3-2](#).

**TABLE 3-2** Specifications (Allowable Contamination)

Contamination	Tolerable Limit
Hydrogen sulfide (H <sub>2</sub> S)	Up to 7.1 ppb
Sulfur dioxide (sulfur oxide) (SO <sub>2</sub> )	Up to 37 ppb
Hydrogen chloride (HCl)	Up to 6.6 ppb
Chlorine (Cl <sub>2</sub> )	Up to 3.4 ppb
Hydrogen fluoride (HF)	Up to 3.6 ppb
Nitrogen dioxide (nitrogen oxide) (NO <sub>2</sub> )	Up to 52 ppb
Ammonia (NH <sub>3</sub> )	Up to 420 ppb
Ozone (O <sub>3</sub> )	Up to 5 ppb

**TABLE 3-2** Specifications (Allowable Contamination) (Continued)

Contamination	Tolerable Limit
Oil vapor	Up to 0.2 mg/m <sup>3</sup>
Dust	Up to 0.15 mg/m <sup>3</sup>
Seawater (salt damage)	The installation site shall not be within 0.5 km of the ocean or coastal areas (unless the computer room uses air conditioners to filter out airborne sea salt particles from outside air).

## 3.2 Cooling Specifications

This section explains the cooling conditions of the M3000 server.

In installing the server, note the following conditions:

- The room should have an adequate air-conditioning system that meets the cooling requirements of the entire server.
- The air-conditioning system should have controls that prevent excessive temperature changes.

[TABLE 3-3](#) shows the cooling specifications of the fully configured M3000 server.

**TABLE 3-3** Cooling Specifications

Configuration	CPU	Input Voltage	Maximum Heat Dissipation	Maximum Exhaust Airflow	Noise Level*
1 CPU, 64 GB memory	CPU: 2.52 GHz	100 VAC to 120 VAC	1,603.7 BTU/hr (1,692 kJ/hr)	1.75 m <sup>3</sup> /min	47 dB
		200 VAC to 240 VAC	1,569.6 BTU/hr (1,656 kJ/hr)		
	CPU: 2.75 GHz	100 VAC to 120 VAC	1,723.1 BTU/hr (1,818 kJ/hr)		
		200 VAC to 240 VAC	1,707.9 BTU/hr (1,800 kJ/hr)		
	CPU: 2.86 GHz	100 VAC to 120 VAC	1,723.1 BTU/hr (1,818 kJ/hr)		
		200 VAC to 240 VAC	1,707.9 BTU/hr (1,800 kJ/hr)		

\* This is a value measured in compliance with ISO7779.

The M3000 server has been designed to operate while mounted in a natural convection airflow. To meet the environmental specifications, the following requirements must be met:

- The entire server must be supplied with an adequate airflow.

The M3000 server uses internal fans that can achieve a total airflow of 1.75 cubic meters per minute (61.8 cubic feet per minute [cfm]) under normal operating conditions.

- The server has front-to-back cooling. The air inlet is at the front of the server. The exhaust air exits from the rear of the server.
- Ensure that the temperature at the air inlet of the server does not exceed the upper limit because of additional equipment installed in the equipment rack. The environmental limits assume that the server is operating in the equipment rack with the ventilation panels closed.

## 3.2.1 Airflow Indicator

The airflow indicator indicates the amount of air emitted from the server while the M3000 server is up and running. To display the value, use the `showenvironment air` command.

### CODE EXAMPLE 3-1

```
XSCF> showenvironment air
Air Flow:63CMH
```

The value does not include the peripheral devices.

---

**Note** – The `showenvironment air` command displays the calculated airflow based on the fan speed such as Low speed (level -1) or High speed (level -7) etc. The fan speed is displayed by the `showenvironment Fan` command.

---

For details of the `showenvironment(8)` command, refer to the man page. For installation details of the M3000 server, see the *SPARC Enterprise M3000 Server Installation Guide*.

You can also obtain the exhaust air data using the SNMP agent function. To obtain the data of exhaust air using the SNMP agent function, install the latest XSCF extension MIB definition file to the SNMP manager. For details on the XSCF extension MIB definition file, see the *SPARC Enterprise M3000/M4000/M5000/M8000/M9000 Servers XSCF User's Guide*.

## 3.3 Power Requirements

This section explains the power requirements of the M3000 server.

### 3.3.1 Electrical Specifications

This section explains the electrical specifications of the M3000 server.

---

**Note** – The electrical power values in [TABLE 3-4](#) are the maximum values based on the fully configured server. The actual values may differ from these values, depending on the server configuration.

---

**TABLE 3-4** Electrical Specifications

Item	Specification			
	CPU: 2.52 GHz		CPU: 2.75 GHz/2.86 GHz	
Input voltage	100 VAC to 120 VAC	200 VAC to 240 VAC	100 VAC to 120 VAC	200 VAC to 240 VAC
Number of power cords	2 (1 cord for each power supply unit)		2 (1 cord for each power supply unit)	
Power cord length	3 m/9.84 ft		3 m/9.84 ft	
Redundancy	1 + 1 redundant configuration		1 + 1 redundant configuration	
Rated current <sup>†</sup>	4.80 A	2.59 A	5.15 A	2.81 A
Frequency	50 Hz/60 Hz		50 Hz/60 Hz	
Maximum power consumption	470 W	460 W	505 W	500 W
Apparent power	480 VA	517 VA	515 VA	562 VA
Heat dissipation	1,603.7 BTU/hr (1,692 kJ/hr)	1,569.6 BTU/hr (1,656 kJ/hr)	1,723.1 BTU/hr (1,818 kJ/hr)	1,707.9 BTU/hr (1,800 kJ/hr)
Power factor	0.98	0.89	0.98	0.89
Rush current <sup>†</sup>	25 A or less		25 A or less	
Leakage current <sup>†</sup>	1.75 mA or less		1.75 mA or less	

\* In a redundant configuration, the rated current per cord is half the value shown in [TABLE 3-4](#).

† This value represents the current for each power cord.



## 3.3.2 Power Cord Specifications

This section explains power cord specifications of the M3000 server. For details of power cord connections, see the *SPARC Enterprise M3000 Server Installation Guide*.

TABLE 3-5 lists the power cord specifications and connector specifications of the M3000 server.

**TABLE 3-5** Power Cords and Connector Specifications

Location	Power Cord Type	Connector Type
Japan	NEMA5-15 125V15A	IEC 60320 C13
North America	NEMAL6-15 250V15A	
China	GB 2099.1 250V15A	
Hong Kong	BS1363 250V15A	
South Korea	IEC60320-C14 250V15A	

**Note** – For the servers that have the plug with lock function, confirm that a 15A overcurrent protection device is available outside the server. If one is not available, prepare an external 15A overcurrent protection that can be achieved by means of no-fuse breakers (NFBs) or fuses. The plug with lock function refers to plugs other than grounding-type ones with two parallel blades, such as the NEMA L6-30, L6-20, L6-15, and L5-15.

## 3.3.3 Power Supply Facility

To prevent catastrophic failures, the design of your power system must ensure that sufficient power is provided to the server. Use dedicated distribution panels for all power circuits that supply power to your server. Electrical work and installation must comply with applicable local, state, or national electrical codes.

Qualified equipment racks housing the M3000 servers require their own AC power outlet. To reduce component failure rates, a stable power source is necessary such as an uninterruptible power supply unit (UPS). If the computer equipment is subjected to repeated power interruptions and fluctuations, it is susceptible to a higher component failure rate than it would be with a stable power source.

---

**Note** – If a suitable AC power outlet is not available in your country, ask a qualified electrician to remove the connector from the power cord and connect the power cord to a dedicated branch circuit. For installation requirements, check the local electrical codes.

---

## 3.3.4 Grounding

The server must be grounded appropriately.

The M3000 server is shipped with two grounding-type (three-wire) power cords. To appropriately ground the server, make sure to connect the power cords to grounded power outlets.

Contact your facilities manager or a qualified electrician to determine what type of power is supplied to your building.

## 3.3.5 Power Consumption Monitoring Function

The power consumption monitoring function confirms the amount of power consumed while the M3000 server is up and running.

To display the power consumption, use the `showenvironment power` command.

### CODE EXAMPLE 3-2

```
XSCF> showenvironment power
Permitted AC power consumption:470W
Actual AC power consumption:450W
```

---

**Note** – The values displayed by the power consumption monitoring function are for reference only. The power consumption value of the server varies by the conditions such as the power supply in use, CPU types, or system configurations, or system load.

---

For details of the `showenvironment(8)` command, see the man page. For installation details of the M3000 server, see the *SPARC Enterprise M3000 Server Installation Guide*.

You can also obtain the power consumption data using the SNMP agent function. To obtain the power consumption data using the SNMP agent function, install the latest XSCF extension MIB definition file to the SNMP manager. For details on the XSCF extension MIB definition file, see the *SPARC Enterprise M3000/M4000/M5000/M8000/M9000 Servers XSCF User's Guide*.

When there is a change in the power system, such as in the following occurrences, wait for one minute, then check the value again.

- During the server power-on or power-off, or after the power-on or power-off is complete
- During the active replacement of a power supply unit, or after the active replacement is complete



# Network Connection

---

This chapter provides an overview of the network connections required for installing and operating the M3000 server. For details of the network connections, see the *SPARC Enterprise M3000 Server Installation Guide*.

- [Section 4.1, “Setup and Network Connection” on page 4-1](#)
- [Section 4.2, “Platform and Domain Setup Information” on page 4-2](#)
- [Section 4.3, “Choosing the System Control Network Configuration” on page 4-3](#)

---

## 4.1 Setup and Network Connection

The serial port on the rear panel of the server is used for the following purposes:

- Connecting the LAN ports for the eXtended System Control Facility (XSCF) to a system control network
- Monitoring the boot process
- Changing the initial values of the XSCF

A system control network is a secure LAN connecting the XSCF to the management console of the system administrator. This connection can be done directly, but it is usually done through a hub or switch specific to the system control network. The initial settings of the LAN ports are done by directly connecting to the serial port.

---

## 4.2 Platform and Domain Setup Information

The following information is required for installation of the M3000 server:

- Host name
- IP address
- Domain
- Net mask
- IP address of the network gateway
- IP address of the network name server

In addition, the following network connections must be available:

- Serial console connection:
  - Baud rate: 9600 bps
  - Data length: 8 bits
  - Parity: None
  - Stop: 1 bit
  - Flow control: None
  - Delay: Except for 0
- Ethernet (10/100BASE-T) connection for the XSCF
- Gigabit Ethernet (GbE)(10/100/1000BASE-T) connection for the domain

---

**Note** – The LAN ports of the XSCF conform to IEEE 802.3i and IEEE 802.3u. For a hub port connection to the LAN of the XSCF, use the auto-negotiation setting.

---

---

## 4.3 Choosing the System Control Network Configuration

In determining the system control network configuration, consider the following:

- The IP address of each LAN port can be assigned in compliance with the existing environment and modified from the default Class B private address.
- The customer may use the dual-power feed or single-power feed option.
- The customer may segregate the LAN port or network for access by field engineers. Otherwise, field engineer access may be through the serial port in the event that maintenance is required.

The following are examples of system control network configurations:

- [Example 1 - One LAN port is used for administration and remote maintenance.](#)
- [Example 2 - Two LAN ports are used separately for administration and remote maintenance.](#)
- [Example 3 - Two LAN ports are used to redundantly configure the LAN.](#)

- **Example 1** - One LAN port is used for administration and remote maintenance.

Only one of the two LAN ports is used for system administration and remote maintenance. A field engineer uses the serial port or the other LAN port. The same switch is used for system administration and remote maintenance, so a switch failure will affect the system control network.

**FIGURE 4-1** Example of a Configuration Using Only One LAN Port

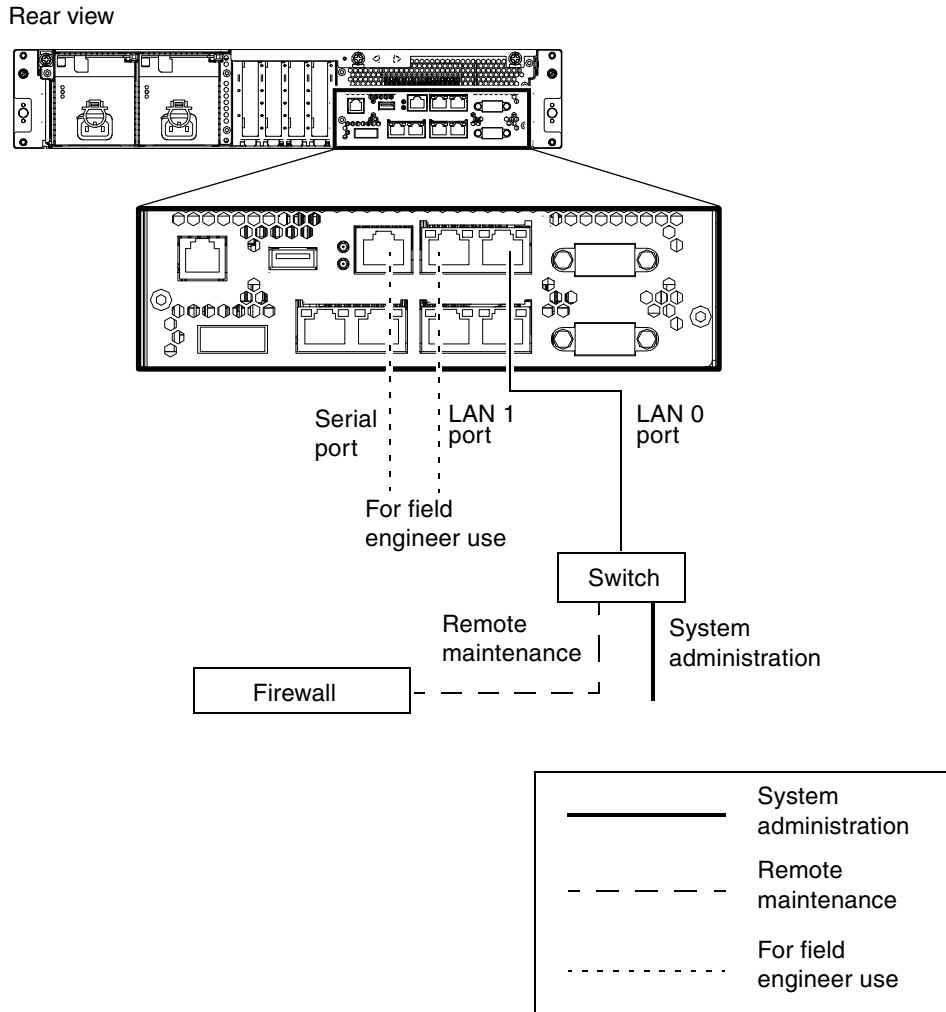



- **Example 2** - Two LAN ports are used separately for administration and remote maintenance.

The two LAN ports are both used. One port is used for system administration, and the other is used for remote maintenance. Even if one switch fails, errors can still be reported. A field engineer uses the serial port or a port on the switch for remote maintenance.

**FIGURE 4-2** Example of a Configuration Using the Two LAN Ports

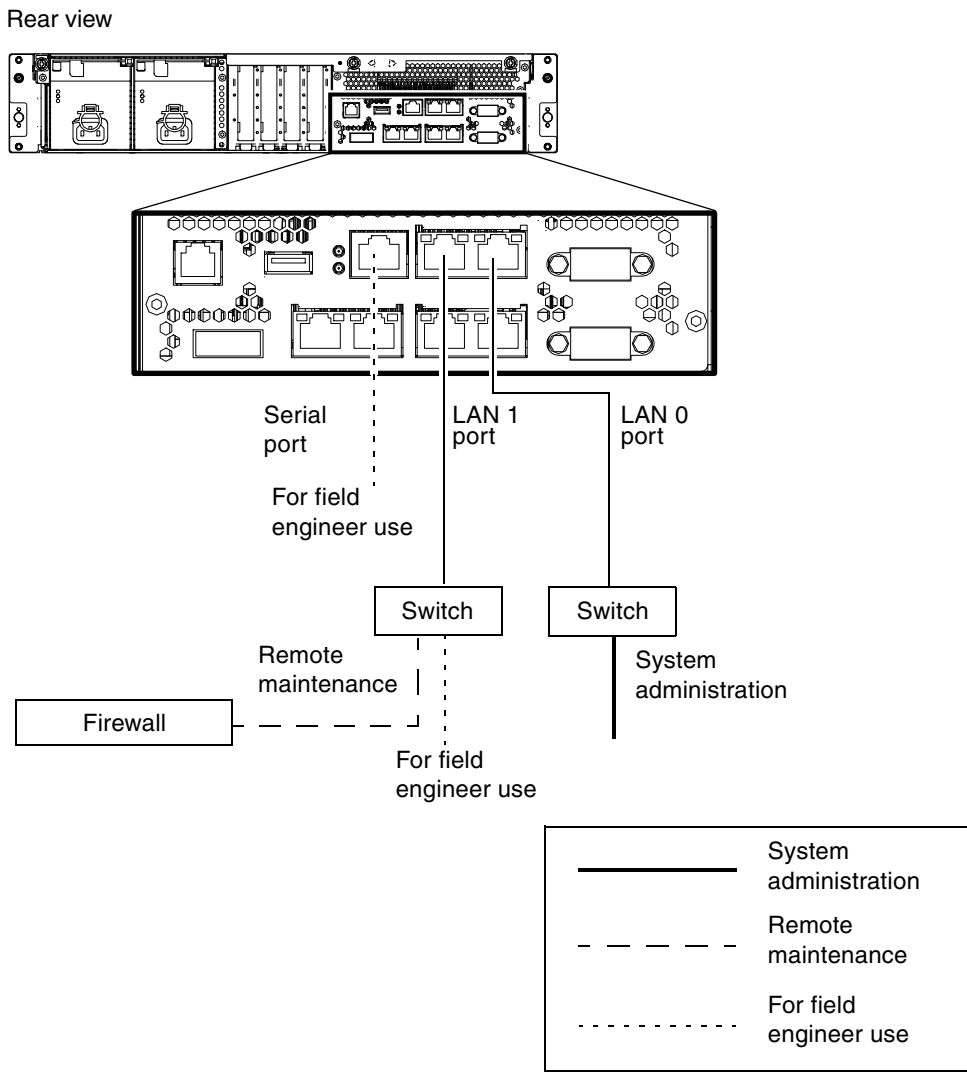

- **Example 3** - Two LAN ports are used to redundantly configure the LAN.

The two LAN ports are both used. Both ports are used for system administration and remote maintenance. A field engineer uses the serial port or the two LAN ports. If one of the LAN ports or the switches fails, the other LAN is used, so the system control network is not affected.

**FIGURE 4-3** Example of a Configuration Using the Two LAN Ports to Redundantly Configure the LAN

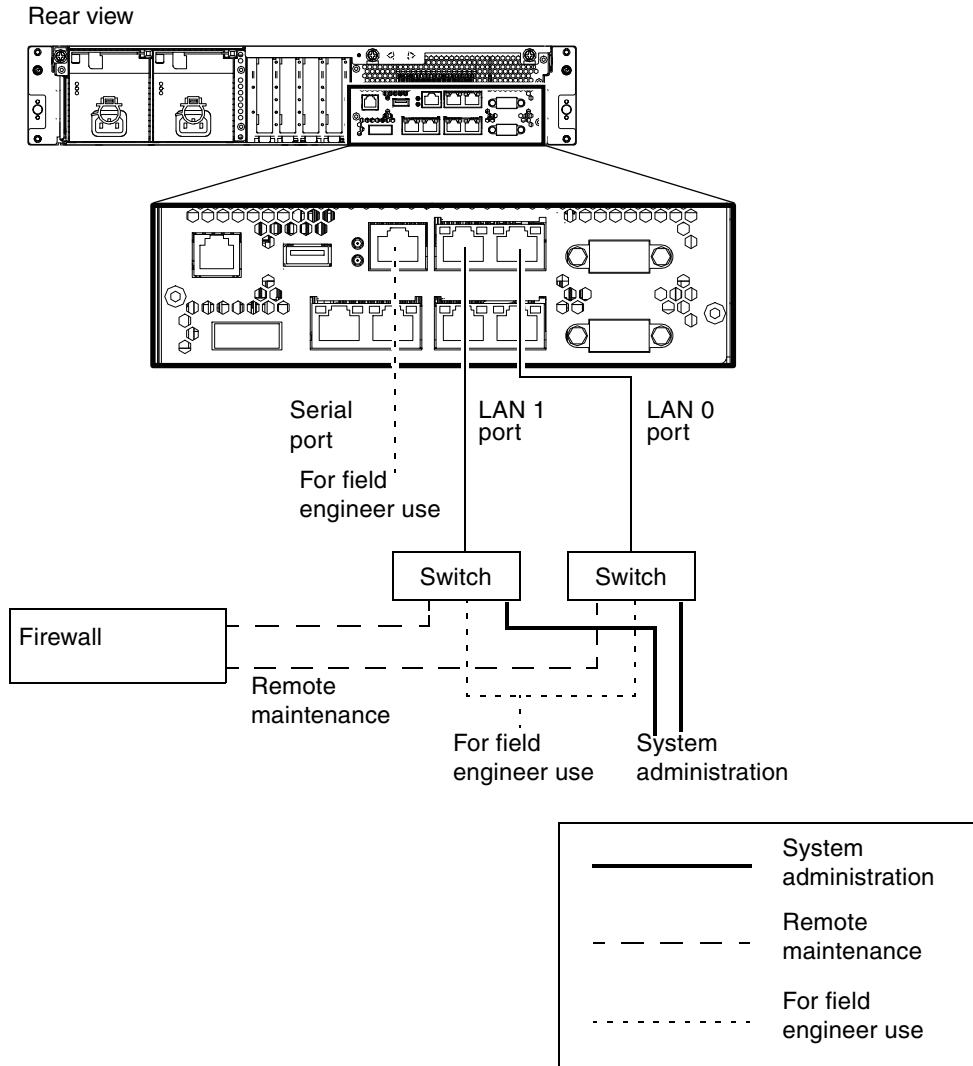

For more information on connecting to a console, see the *SPARC Enterprise M3000 Server Installation Guide*.

# UPS Controller

---

This appendix explains the UPS controller (UPC), which controls an uninterruptible power supply unit (UPS).

- [Section A.1, “Overview” on page A-1](#)
- [Section A.2, “Signal Cables” on page A-2](#)
- [Section A.3, “Signal Line Configuration” on page A-2](#)
- [Section A.4, “Cable Connector” on page A-4](#)

---

## A.1 Overview

A UPS unit is used to provide a stable supply of power to the system in the event of a power failure or an extensive power interruption.

When a failure is detected in the supply of power, an error can be reported to the server through the signal cable connection between a UPC port on the server and a UPS that has the UPC interface. Then the server can execute emergency shutdown processing to safely shut down the system.

FIGURE A-1 shows the locations of the UPC ports on the M3000 server.

FIGURE A-1 UPC Port Locations

Rear view

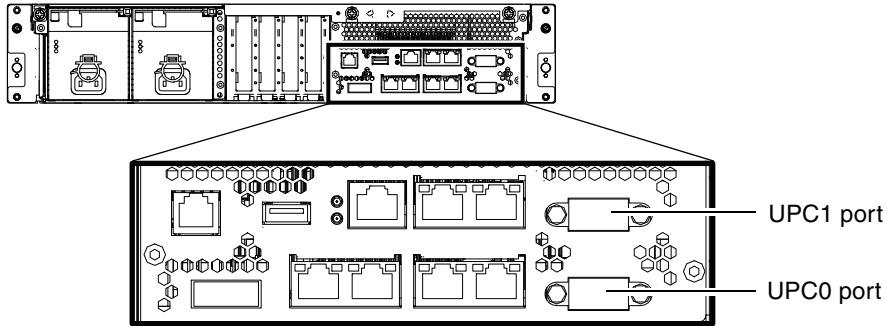

---

## A.2 Signal Cables

Prepare shielded and paired cables that have the following specifications:

- DC resistance (roundtrip/1 pair): 400  $\Omega$ /km or less
- Cable length: Up to 10 m (33 ft.)

---

## A.3 Signal Line Configuration

This section describes signal line configuration and definitions when connected to a UPS.

FIGURE A-2 shows the signal line configuration when connected to a UPS.

**FIGURE A-2** Connection With UPS and the Server

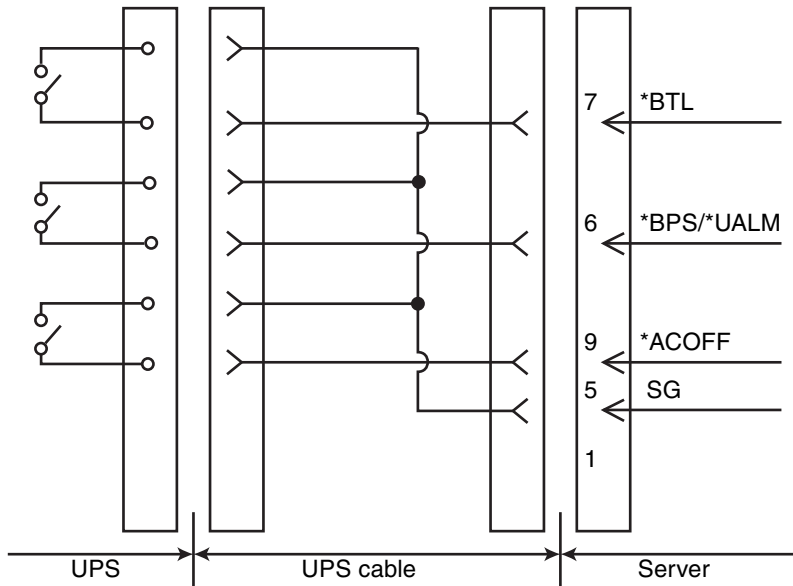

**TABLE A-1** Signal Definitions

Signal Name	Definitions	Pin Number	Remarks
*BPS/*UALM	Signal indicates faulty UPS conditions.	6	Normal: OFF Failure: ON
*BTL	Signal provides a warning of a low battery level and a pending UPS failure.	7	Normal: OFF Warning: ON (Note1)
*ACOFF	Signal indicates power failure at the commercial AC supply connector to the UPS.	9	Normal: OFF Power failure: ON (Note2)
SG	Signal ground	5	
ER	Signal indicates the main unit is running (Equipment Ready).	1	Do not connect to ER signal pin.

ON: Indicates that the contact is closed.

OFF: Indicates that the contact is open.

Note 1: Use a UPS that can normally supply power from the battery at least 10 to 60 seconds after \*BTL is turned on.

Note 2: Use a UPS that can supply power normally from its battery even if \*ACOFF does not turn on in the event of an instantaneous power failure lasting two seconds or less.

## A.4 Cable Connector

The UPS cable has the following specifications:

- Connector type  
D-SUB9 pin Male (install side: Female)  
DEU-9PF-F0
- Terminal array

**FIGURE A-3** identifies pin signals of the UPC port and the UPS cable.

Do not use the unused pins (pin number 2, 3, 4 and 8 in the following diagram).  
Cable side shown below.

**FIGURE A-3** Correspondence Between the UPC Ports and the UPS Cable Pins

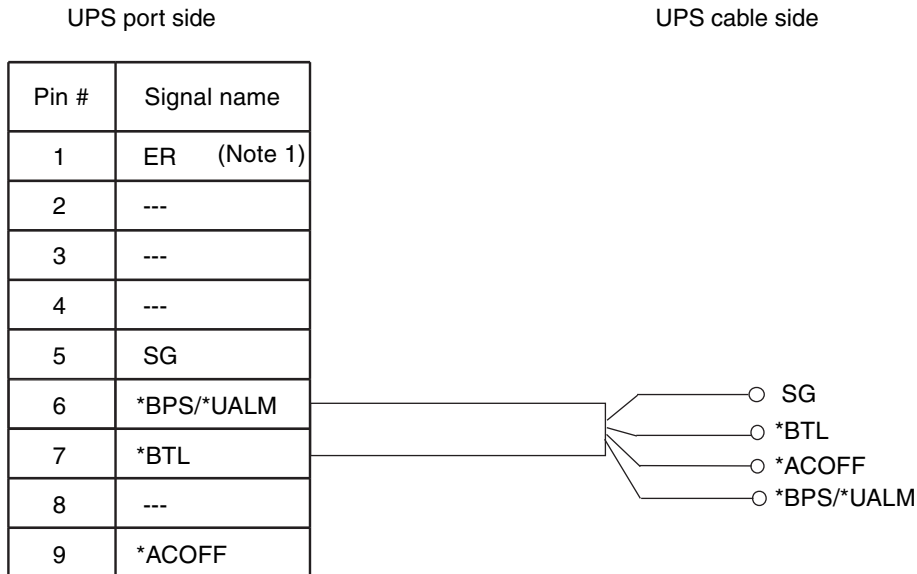

Note 1: Do not connect to ER signal pin.

---

**Note** – If you need UPS cables, you need to make arrangements separately. For details, contact your sales representatives.

---

# DC Power Supply Model

---

This appendix explains specifications and requirements specific to the DC power supply model.

Contact your sales representative for the DC power supply model.

To use the DC power supply model, make sure to read this information.

- [Section B.1, “Server Installation Guidelines” on page B-1](#)

This is equivalent to [Section 2.2, “Server Installation Guidelines” on page 2-3](#). When using the DC power supply model, refer to the content described in this appendix.

- [Section B.2, “Cooling Specifications” on page B-2](#)

This is equivalent to [Section 3.2, “Cooling Specifications” on page 3-4](#). When using the DC power supply model, refer to the content described in this appendix. However, the [Section 3.2.1, “Airflow Indicator” on page 3-5](#) is common to AC power supply model and DC power supply model.

- [Section B.3, “Power Requirements” on page B-4](#)

This is equivalent to [Section 3.3, “Power Requirements” on page 3-6](#). When using the DC power supply model, refer to the content described in this appendix.

---

**Note** – The content not mentioned in this appendix is common to the AC power supply model and the DC power supply model. Refer to the description in each chapter.

---

---

## B.1 Server Installation Guidelines

This section explains the installation guidelines for the DC power supply model.

---

**Note** – This is equivalent to [Section 2.2, “Server Installation Guidelines”](#) on [page 2-3](#). When using the DC power supply model, refer to the content described in this appendix.

---

As you plan the installation of the DC power supply model, keep the following conditions in mind:

- Each server requires two power cords. Each power cord must be connected to a separate input power source. When using the dual power feed option, the power cords must be connected to separate power supply facilities.
- The power supply facility must meet the relevant electrical codes.
- Install the DC power supply model in a location where you can restrict access to the area. A location where you can restrict access to the area refers to a place provided with some way of lock-up mechanism such as keys or the locks using the access cards.

For details of the server installation, see the *SPARC Enterprise M3000 Server Installation Guide*.

---

## B.2 Cooling Specifications

This section explains the cooling conditions for the DC power supply model.

---

**Note** – This is equivalent to [Section 3.2, “Cooling Specifications”](#) on [page 3-4](#). When using the DC power supply model, refer to the content described in this appendix.

---

In installing the server, note the following conditions:

- The room should have an adequate air-conditioning system that meets the cooling requirements of the entire server.
- The air-conditioning system should have controls that prevent excessive temperature changes.

[TABLE B-1](#) shows the cooling specifications of the fully configured M3000 server.



**TABLE B-1** Cooling Specifications

Configuration	CPU	Input Voltage	Maximum Heat Dissipation	Maximum Exhaust Airflow	Noise Level*
1 CPU, 64 GB memory	CPU:2.75 GHz	-48 Vdc	1,723.1 BTU/hr (1,818 kJ/hr)	1.75 m <sup>3</sup> /min	47 dB
		-60 Vdc	1,740.2 BTU/hr (1,836 kJ/hr)		
	CPU:2.86 GHz	-48 Vdc	1,723.1 BTU/hr (1,818 kJ/hr)		
		-60 Vdc	1,740.2 BTU/hr (1,836 kJ/hr)		

\* This is a value measured in compliance with ISO7779.

The M3000 server has been designed to operate while mounted in a natural convection airflow. To meet the environmental specifications, the following requirements must be met:

- The entire server must be supplied with an adequate airflow.

The M3000 server uses internal fans that can achieve a total airflow of 1.75 cubic meters per minute (61.8 cubic feet per minute [cfm]) under normal operating conditions.

- The server has front-to-back cooling. The air inlet is at the front of the server. The exhaust air exits from the rear of the server.
- Ensure that the temperature at the air inlet of the server does not exceed the upper limit because of additional equipment installed in the equipment rack. The environmental limits assume that the server is operating in the equipment rack with the ventilation panels closed.

---

## B.3 Power Requirements

This section explains the power requirements for the DC power supply model.

---

**Note** – This is equivalent to [Section 3.3, “Power Requirements”](#) on page 3-6. When using the DC power supply model, refer to the content described in this appendix.

---

### B.3.1 Electrical Specifications

This section explains the electrical specifications of the DC power supply model.

---

**Note** – The electrical power values in [TABLE B-2](#) are the maximum values based on the fully configured server. The actual values may differ from these values, depending on the server configuration.

---

**TABLE B-2** Electrical Specifications

Item	Specification	
	CPU: 2.75 GHz/2.86 GHz	
Input voltage	-48 Vdc	-60 Vdc
Number of power cords	2 (1 cord for each power supply unit)	
Power cord length	5 m/16.4 ft	
Redundancy	1 + 1 redundant configuration	
Rated current*	10.52 A	8.50 A
Frequency	-	-
Maximum power consumption	505 W	510 W
Apparent power	-	-
Heat dissipation	1,723.1 BTU/hr (1,818 kJ/hr)	1,740.2 BTU/hr (1,836 kJ/hr)
Power factor	-	-

\* In a redundant configuration, the rated current per cord is half the value shown in [TABLE B-2](#).

## B.3.2 Power Cord Specifications

This section explains power cord specifications of the DC power supply model. For details of power cord connections, see the *SPARC Enterprise M3000 Server Installation Guide*.

TABLE B-3 lists the power cord specifications of the DC power supply model.

**TABLE B-3** Power Cords and Connector Specifications

Item	Specification
Connector	294-0085-00100A of ELCON
Cord structure	Three AWG 14 wires
Cord length	5 m

FIGURE B-1 shows the structure of the DC power cord.

**FIGURE B-1** Structure of DC Power Cord

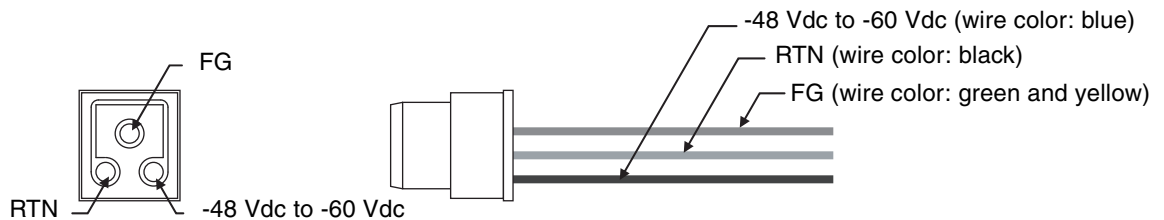

The DC power cord supplied with the server has a connector only for the server end. Therefore, a terminal matching the DC power supply facility will need to be attached to the DC power supply end of the cord.

To prevent signal attenuation, a voltage drop caused by conductor impedance must be suppressed down to less than 2 % of the reference voltage. If the voltage of the DC power supply facility is other than the above voltage, use a cord length that ensures that the voltage drop is suppressed to 2 % or less.

For the allowable cord length (each for -48 Vdc and -60 Vdc) between the DC power supply facility and the server, contact your service engineer.

## B.3.3 Power Supply Facility

To prevent catastrophic failures, the design of your power system must ensure that sufficient power is provided to the server. Use dedicated distribution panels for all power circuits that supply power to your server. Electrical work and installation must comply with applicable local, state, or national electrical codes.

Observe the following precautions, when mounting the DC power supply model in the qualified equipment rack.

- Always mount overcurrent protective devices between the server and DC power supply facility. One overcurrent protective device is required for each power supply line. The overcurrent protective devices must comply with the following specifications:
  - Current rating: 30 A
  - Voltage rating: 65 Vdc or more
  - Operation type: Immediate shutdown type (however, overcurrent protective devices should not operate against 1 ms rush currents with a peak current of 100 A)
  - Number of poles: 2 (-48 Vdc to -60 Vdc line and RTN line)
- The power supply that can be used with the M3000 server is restricted to DC power supply facility that is separate from the AC power, or DC power supply facility that has double or reinforced insulation for high, dangerous voltages.
- The DC power supply facilities must be capable of continuously supplying the following capacity to each of the power cords.
  - Power requirements: 510 W

When attaching an overcurrent protective device, consider protective coordination with the fuse provided in the server. Attach an overcurrent protective device that has slower cutoff characteristics than the fuse in the server.

FIGURE B-2 shows the cutoff characteristics of the fuse provided in the server.

FIGURE B-2 Cutoff Characteristics of Overcurrent Protective Device

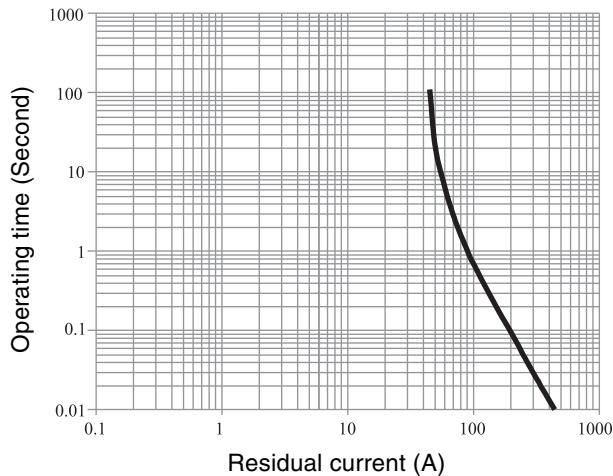

## B.3.4 Grounding

The server must be grounded appropriately.

The DC power supply model of the M3000 server is shipped with two DC power cords. Since these DC power cords have a connector only for the server end, a terminal matching the DC power supply facility will need to be attached to the DC power supply end of the cord. Moreover, the power supply facility must be correctly grounded. Confirm that the grounding prong is connected to the positive bus on the battery box.

The grounding resistance must not be greater than 10  $\Omega$ . Make sure that the facility administrator or a qualified electrician verifies the grounding method for the building and performs the grounding work.

## B.3.5 Power Consumption Monitoring Function

The power consumption monitoring function confirms the amount of power consumed while the M3000 server is up and running.

To display the power consumption, use the `showenvironment power` command.

```
XSCF> showenvironment power
Permitted DC power consumption:470W
Actual DC power consumption:450W
```

---

**Note** – The values displayed by the power consumption monitoring function are for reference only. The power consumption value of the server varies by the conditions such as the power supply in use, CPU types, or system configurations, or system load.

---

For details of the `showenvironment(8)` command, see the man page. For installation details of the SPARC Enterprise M3000 server from Oracle and Fujitsu, see the *SPARC Enterprise M3000 Server Installation Guide*.

You can also obtain the power consumption data using the SNMP agent function. To obtain the power consumption data using the SNMP agent function, install the latest XSCF extension MIB definition file to the SNMP manager. For details on the XSCF extension MIB definition file, see the *SPARC Enterprise M3000/M4000/M5000/M8000/M9000 Servers XSCF User's Guide*.

When there is a change in the power system, such as in the following occurrences, wait for one minute, then check the value again.

- During the server power-on or power-off, or after the power-on or power-off is complete
- During the active replacement of a power supply unit, or after the active replacement is complete

# Index

---

## A

air-conditioning system, 3-4, B-2  
airflow  
    requirements, 3-5, B-3  
airflow indicator, 3-5  
ambient relative humidity, 3-3  
ambient temperature, 3-2

## C

components, 2-1  
Contamination Specifications, 3-3  
cooling specifications, 3-4, B-2

## D

DC power supply model, B-1  
domain setup, 4-2

## E

electrical specifications, 3-6, B-4  
electrostatic discharge, 3-3  
environmental requirements, 3-1  
external dimensions, 2-5

## G

grounding, 3-8, B-7

## O

optimum, 3-2

## P

power consumption monitoring function, 3-8, B-8

power cord, 2-3, 3-7, B-2, B-5  
power facilities, 3-6, B-6  
power requirements, 3-6, B-4

## S

service clearance, 2-3  
specifications, 2-1  
system control network, 4-3  
    configuration example, 4-4, 4-5, 4-6

## T

thermal clearance, 2-5

## U

UPS, A-1, B-1  
UPS controller, A-1  
    cable connector, A-4  
    signal cables, A-2  
    signal line configuration, A-2

