

24V DRIVE, FTP-60A SERIES ULTRA HIGH SPEED (250mm/s) 3" TYPE MECHANISM (with cutter option)

FTP-63AMCL001/011/401/411-R

■ OVERVIEW

The FTP-60AMCL Series thermal printer (driven by 24VDC) provides ultra-high speed printing (250mm/s) for 3-inch wide paper.

This series is suitable for a variety of applications, such as ATM, kiosk terminals, ticket machines, label printers, banking machines, measuring devices, medical equipment, etc.

■ HIGHLIGHTS

- **Ultra high speed printing**
It can print at 250 mm/s (2000 dotlines/s) maximum by using Fujitsu Components' unique head drive control.
- **2-D Barcode printing**
QR, Maxi, PDF417
- **ELM (Easy Loading Mechanism) with replaceable thermal head**
Fujitsu Components' unique platen release mechanism allows easy paper loading and easy head maintenance. 150km life minimum.
- **Auto Cutter**
Printer with auto cutter (full cut/ partial cut) is available. It can be mounted in front of the mechanism. 1 million cuts minimum.
- **Heavy duty diecast frame**
By application of heavy duty diecast frame, continuous printing by function of heat-sink, high ESD with stand by function of earth frame and shock/vibration with stand by function of solid frame are valid.
- **Compact size**
Depth: 54mm (with cutter), width: 118.4mm, height: 30mm.
- **Wide temperature range**
-20°C to +70°C.
- **RoHS compliant**



FTP-63AMCL011



FTP-63AMCL411

■ PART NUMBERS

Name			Part Number
Printer mechanism	with FFC connector* ¹	Changeable head	FTP-63AMCL001
	with header connector		FTP-63AMCL011
Mechanism with cutter	with FFC connector* ¹	Guillotine	FTP-63AMCL401
	with header connector		FTP-63AMCL411
Interface cable (board to mechanism)		Head	FTP-62AY001
		Platen / cutter motor	FTP-62AY003

*1: Requires Flat Flexible Cable (FFC)

■ GENERAL SPECIFICATIONS

Item		Specifications	
Part number		FTP-63AMCL001/011	FTP-63AMCL401/411
Printing method		Thermal sensitive line dot method	
Dot structure		640 dots/line	
Dot pitch (horizontal)		0.125mm (8dots/mm) - Dot density	
Dot pitch (vertical)		0.125mm x 0.16mm - Line feed pitch	
Effective printing area		80 mm maximum	
Paper width		80-85mm +0/-1	
Paper thickness		60-150μm	
Cutting type		-	Guillotine (full or partial cut)
Printing speed	FTP-62ADSL series	200mm/sec. (1600 dot lines/sec.) line mode 250mm/sec. (2000 dot lines/sec.) page mode	
Power supply	For head	24 VDC ±5%, 5.7A (11.2A) (24V, 25% printing ratio)	
	For printer motor	24 VDC ±5% 1.2A maximum	
	For cutter motor	---	24 VDC ±5% 1.2A maximum
	For logic	3.3 to 5 VDC ±5% 0.2A maximum	
Dimension W x D x H	Printer mechanism	112 x 50 x 30 /38.2mm	-
	Printer mechanism with cutter	-	119.1 x 54 x 30 /38.2mm
Weight	Printer mechanism	Approximately 180/185g	-
	Printer mechanism with cutter	-	Approximately 335/340g
Life	Head	Pulse durability: 150 million pulse/dot (using Fujitsu's standard driving method) Wear resistance: 150km (at 12.5% print ratio)	
	Cutter	-	1,000,000 cuts minimum
	Platen	5,000 times (open/close)	
Environmental conditions	Operating temperature	-20°C to +70°C (guarantee)	-20°C to +70°C (guarantee)
	Operating humidity	20 to 85% RH (no condensation)	
	Storage temperature	-25°C to +75°C	-25°C to +75°C
	Storage humidity	5 to 95% RH (no condensation)	
Detection	Head temperature	By thermistor	
	Paper out/Mark detect	By photointerruptor	
	Head release	By slide switch	

FTP-63AMCL001/011/401/411

Item		Specifications	
Part number		FTP-63AMCL001/011	FTP-63AMCL401/411
Recommended thermal sensitive paper	High sensitive paper	TF50KS-E4 (Nippon paper)	
	Standard paper	TF60KS-E2 (Nippon paper), FTP-030P0104 (80mm) PD150R (Oji paper), FTP-030P0701 (80mm)	
	Medium life storage paper	TF60KS-F1 (Nippon paper), FTP-030P0102 (80mm) PD170R (Oji paper) P220VBB-1 (Mitsubishi paper) PD160R-N (Oji paper)	
	Long life storage paper	AFP-235 (Mitsubishi paper) TP50KJ-R (Nippon paper) HA220AA (Nippon paper)	

■ DIMENSIONS

1. Printer mechanism

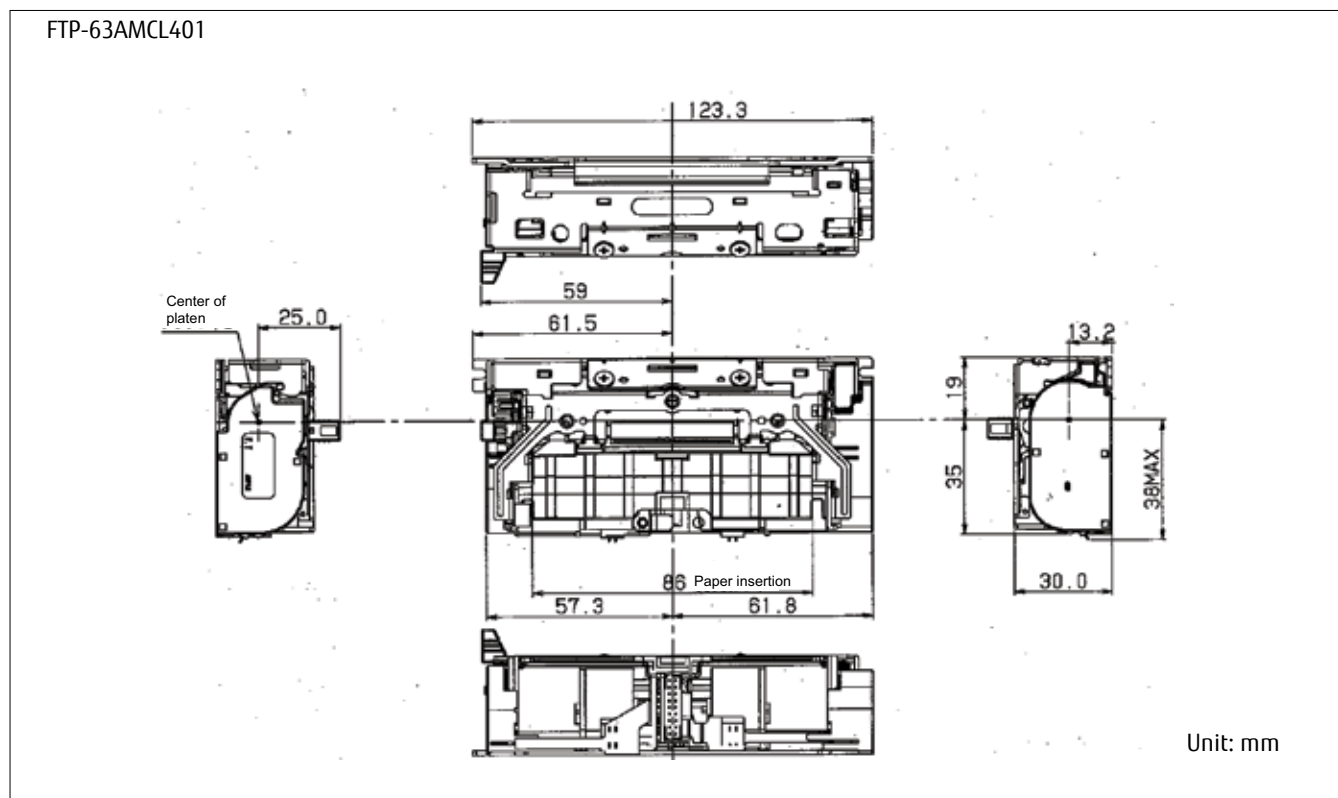
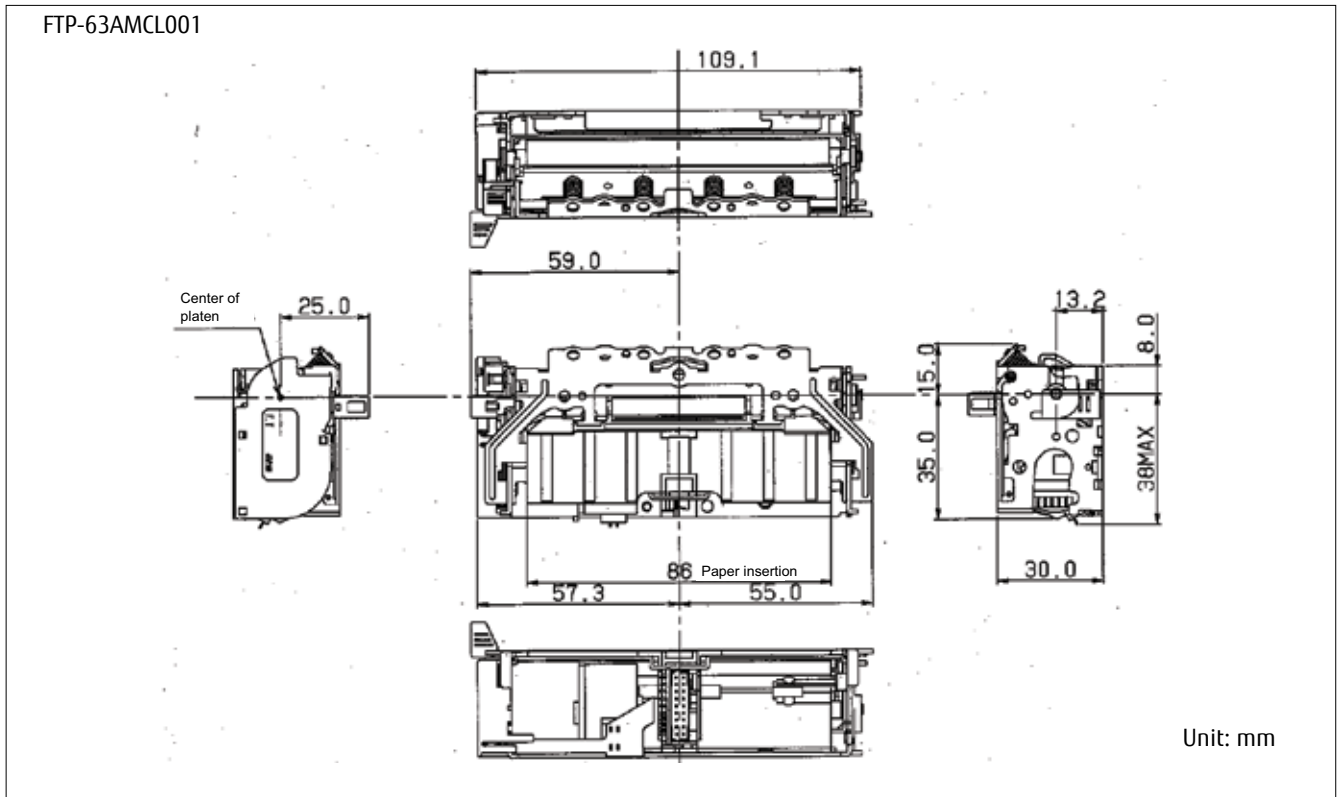

■ CONNECTOR PIN ASSIGNMENT OF PRINTER MECHANISM (FPC)

1. Thermal head control circuit side

a. FPC type (FTP-63AMCL001/401)

Printer mechanism side: FPC / FFC
 Control circuit side: for 1.25mm pitch x 28pins

b. Adaptor Board type (FTP-63AMCL011/411)

Printer mechanism side: B28B-PHDSS (J.S.T)
 Control circuit side: PHDR-28VS (J.S.T)

No.	Signal	I/O	Contents	No.	Signal	I/O	Contents
1	VH		Head drive power	2	VH		Head drive power
3	VH		Head drive power	4	VH		Head drive power
5	DO 1	O	Data out 1	6	DI 1		Data in 1
7	GND	-	Head ground	8	GND	-	Head ground
9	GND	-	Head ground	10	GND	-	Head ground
11	GND	-	Head ground	12	STB 1		Strobe 1
13	CLK		Clock	14	$\overline{\text{LAT}}$		Data latch
15	Vdd		Logic	16	TH	O	Thermistor
17	TH	O	Thermistor	18	STB 2		Strobe 2
19	GND	-	Ground	20	GND	-	Ground
21	GND	-	Ground	22	GND	-	Ground
23	DO 2	O	Data out 2	24	DI 2		Data in 2
25	VH		Head drive power	26	VH		Head drive power
27	VH		Head drive power	28	VH		Head drive power

2. Motor, Sensor (CN4)

Printer mechanism side: LY20-18P-DLT1-P1E (JAE)
 Control circuit side: LY10-DC18 (JAE)

FTP-63AMCL001/011

No.	Signal	I/O	Contents	No.	Signal	I/O	Contents
1	N.C.	-	Not connected	2	N.C.	-	Not connected
3	N.C.	-	Not connected	4	N.C.	-	Not connected
5	N.C.	-	Not connected	6	N.C.	-	Not connected
7	N.C.	-	Not connected	8	TH	-	Thermistor
9	TH	-	Thermistor	10	PHK-P	-	Paper detection photointerruptor (cathode)
11	MT $\underline{\text{A}}$		Motor excitation signal $\underline{\text{A}}$	12	PHE-P	O	Paper detection photointerruptor (emitter)
13	MT B		Motor excitation signal B	14	VSEN		Power supply for photointerruptor
15	MT $\overline{\text{B}}$		Motor excitation signal $\overline{\text{B}}$	16	PHK-L	-	Lever detection photointerruptor (cathode)
17	MT $\overline{\text{A}}$		Motor excitation signal $\overline{\text{A}}$	18	PHE-L	O	Lever detection photointerruptor (emitter)

FTP-63AMCL401/411

No.	Signal	I/O	Contents	No.	Signal	I/O	Contents
1	MT A		Motor excitation signal A (cutter)	2	MT B		Motor excitation signal B (cutter)
3	MT B		Motor excitation signal B (cutter)	4	MT A		Motor excitation signal A (cutter)
5	VSEN		Power supply for photointerruptor	6	PHE-C	O	Cutter photointerruptor (emitter)
7	PHK-C	-	Cutter photointerruptor (cathode)	8	TH	O	Thermistor
9	TH	O	Thermistor	10	PHK-P	-	Paper detection photointerruptor (cathode)
11	MT A		Motor excitation signal A (paper)	12	PHE-P	O	Paper detection photointerruptor (emitter)
13	MT B		Motor excitation signal B (paper)	14	VSEN		Power supply for photointerruptor
15	MT B		Motor excitation signal B (paper)	16	PHK-L	-	Lever detection photointerruptor (cathode)
17	MT A		Motor excitation signal A (paper)	18	PHE-L	O	Lever detection photointerruptor (emitter)

Fujitsu Components International Headquarter Offices

Contact

Japan

FUJITSU COMPONENT LIMITED
Shinagawa Seaside Park Tower
12-4, Higashi-shinagawa 4-chome,
Tokyo 140 0002, Japan
Tel: (81-3) 3450-1682
Fax: (81-3) 3474-2385
Email: fcl-contact@cs.jp.fujitsu.com
Web: www.fujitsu.com/jp/fcl/

Europe

FUJITSU COMPONENTS EUROPE B.V.
Diamantlaan 25
2132 WV Hoofddorp
Netherlands
Tel: (31-23) 5560910
Fax: (31-23) 5560950
Email: info@fceu.fujitsu.com
Web: www.fujitsu.com/uk/components/

China

FUJITSU ELECTRONIC COMPONENTS
(SHANGHAI) CO., LTD.
Unit 4306, InterContinental Center
100 Yu Tong Road, Shanghai 200070, China
Tel: (86 21) 3253 0998
Fax: (86 21) 3253 0997
Email: fcal@sgfujitsu.com
www.fujitsu.com/sg/products/devices/components/

North and South America

FUJITSU COMPONENTS AMERICA, INC.
2290 North First Street, Suite 212
San Jose, CA 95131 U.S.A.
Tel: (1-408) 745-4900
Fax: (1-408) 745-4970
Email: components@us.fujitsu.com
Web: http://us.fujitsu.com/components/

Asia Pacific

FUJITSU COMPONENTS ASIA, Ltd.
102E Pasir Panjang Road
#01-01 Citilink Warehouse Complex,
Singapore 118529
Tel: (65) 6375-8560 / Fax: (65) 6273-3021
Email: fcal@sg.fujitsu.com
www.fujitsu.com/sg/products/devices/components/

Hong Kong

FUJITSU COMPONENTS HONG KONG Co., Ltd.
Unit 503, Inter-Continental Plaza,
No.94 Granville Road,
Tsim Sha Tsui Kowloon, Hong Kong 118529
Tel: (852) 2881 8495 Fax: (852) 2894 9512
Email: fcal@sg.fujitsu.com
www.fujitsu.com/sg/products/devices/components/

Copyright

All trademarks or registered trademarks are the property of their respective owners.

Fujitsu Components America or its affiliates do not warrant that the content of datasheet is error free. In a continuing effort to improve our products Fujitsu Components America, Inc. or its affiliates reserve the right to change specifications/datasheets without prior notice.

Copyright ©2016 Fujitsu Components America, Inc. All rights reserved. Revised January 7, 2016