

# CHAPTER 3 Installation Conditions

- 3.1 Dimensions
- 3.2 Mounting
- 3.3 Cable Connections
- 3.4 Jumper Settings

This chapter gives the external dimensions, installation conditions, surface temperature conditions, cable connections, and switch settings of the hard disk drives.

For information about handling this hard disk drive and the system installation procedure, refer to the following Integration Guide.  
C141-E144

### 3.1 Dimensions

Figure 3.1 illustrates the dimensions of the disk drive and positions of the mounting screw holes. All dimensions are in mm.

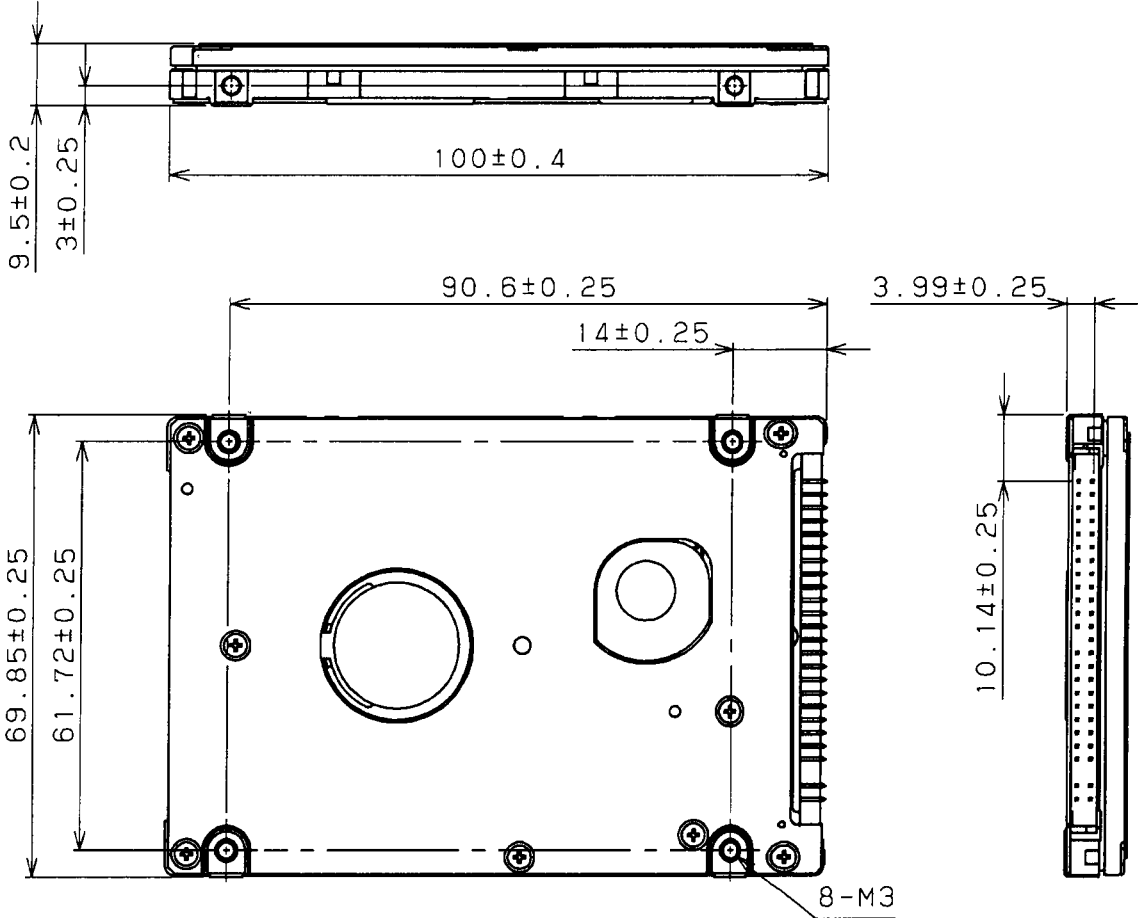

Figure 3.1 Dimensions

## 3.2 Mounting

For information on mounting, see the "FUJITSU 2.5-INCH HDD INTEGRATION GUIDANCE (C141-E144)."

### (1) Orientation

Figure 3.2 illustrates the allowable orientations for the disk drive.

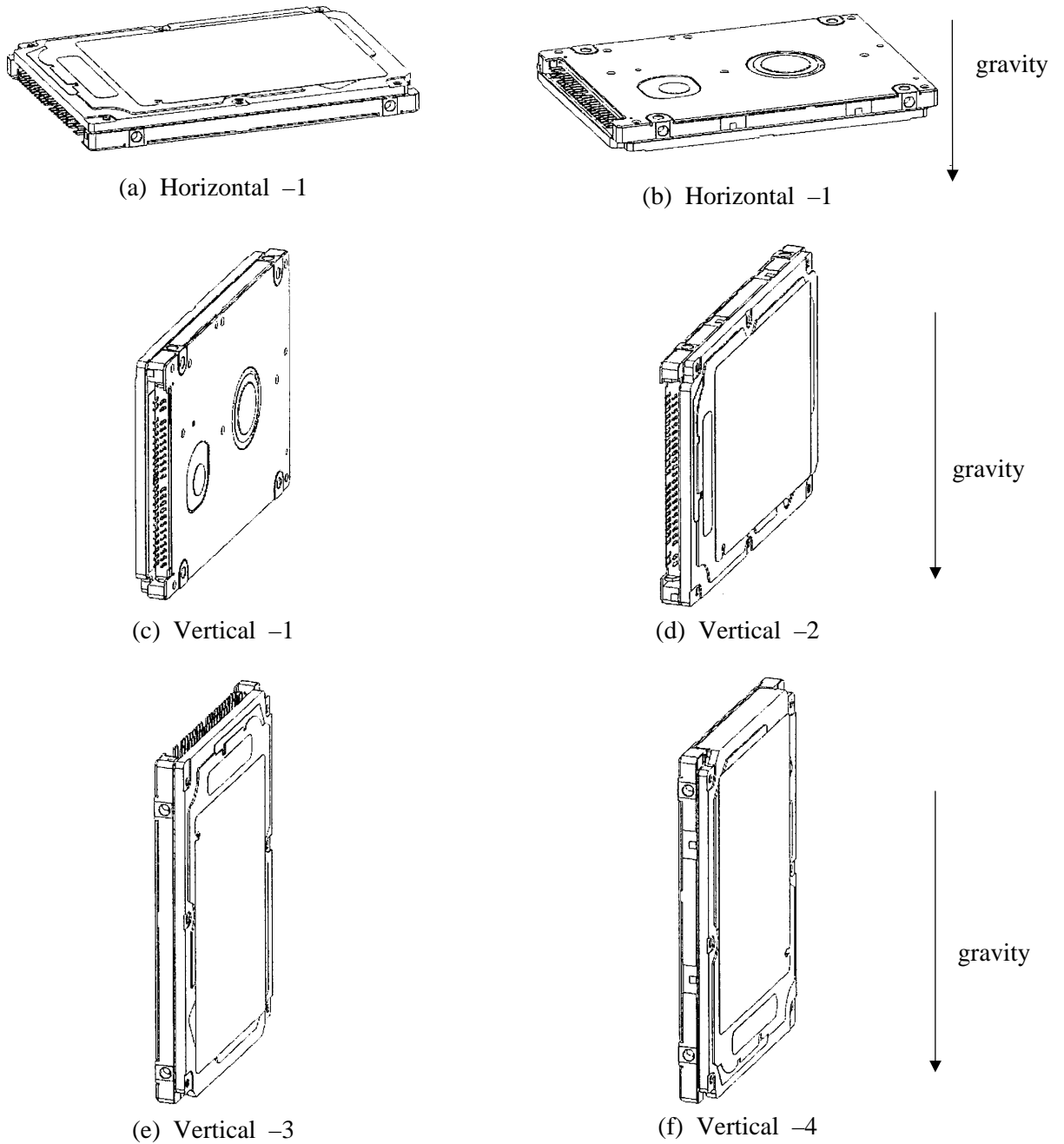

**Figure 3.2 Orientation**

(2) Frame

The MR head bias of the HDD disk enclosure (DE) is zero. The mounting frame is connected to SG.

**IMPORTANT**

Use M3 screw for the mounting screw and the screw length should satisfy the specification in Figure 3.3.

The tightening torque must be 0.49N•m (5kgf•cm).

When attaching the HDD to the system frame, do not allow the system frame to touch parts (cover and base) other than parts to which the HDD is attached.

(3) Limitation of mounting

Note) These dimensions are recommended values; if it is not possible to satisfy them, contact us.

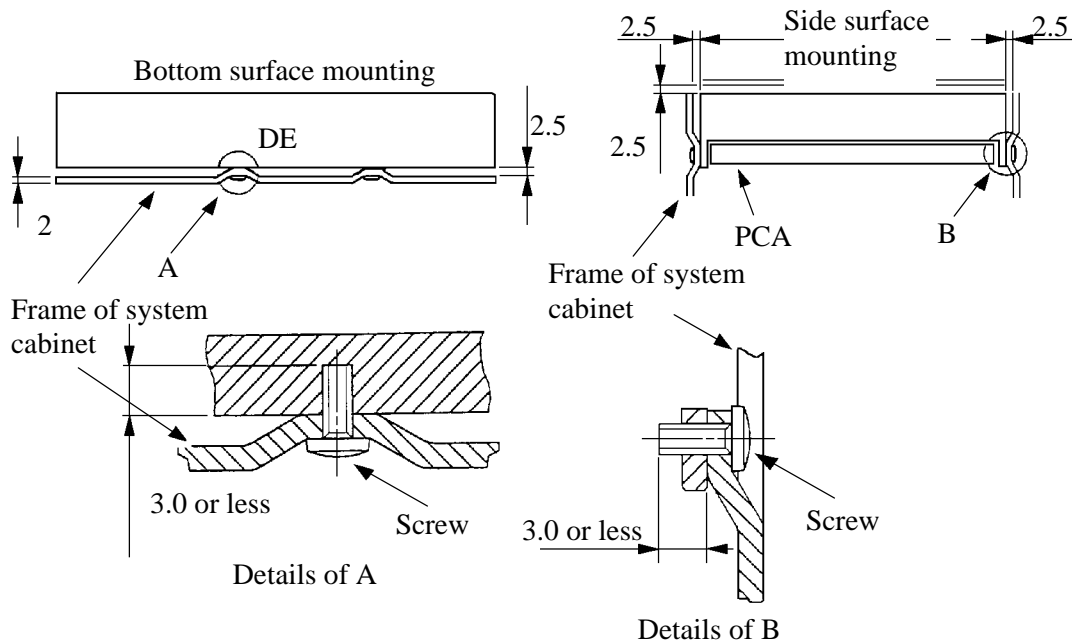

**Figure 3.3 Mounting frame structure**

**IMPORTANT**

Because of breather hole mounted to the HDD, do not allow this to close during mounting.

Locating of breather hole is shown as Figure 3.4.

For breather hole of Figure 3.4, at least, do not allow its around  $\phi 2.4$  to block.

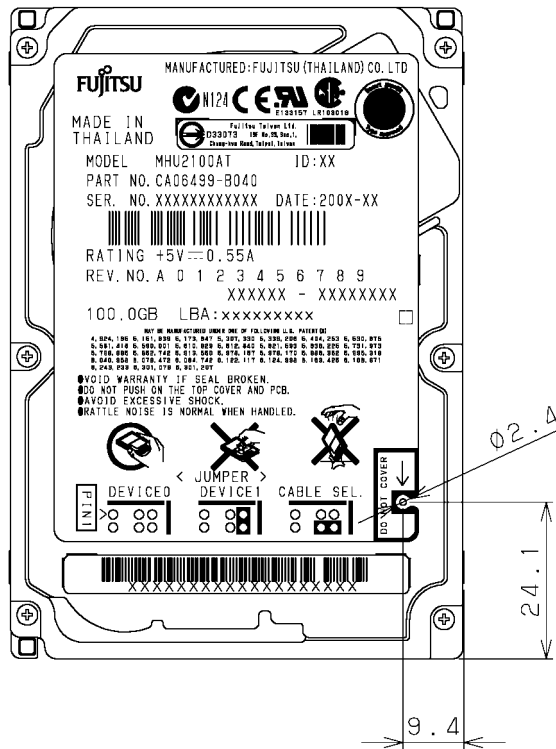
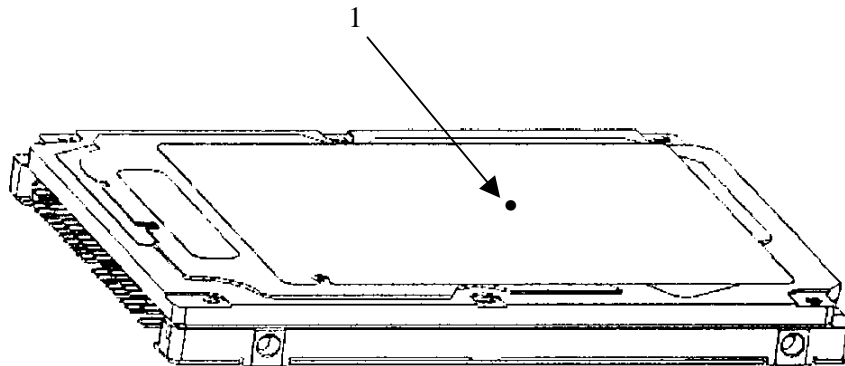

**Figure 3.4 Location of breather**

(4) Ambient temperature

The temperature conditions for a disk drive mounted in a cabinet refer to the ambient temperature at a point 3 cm from the disk drive. The ambient temperature must satisfy the temperature conditions described in Section 1.4, and the airflow must be considered to prevent the DE surface temperature from exceeding 60 °C.

Provide air circulation in the cabinet such that the PCA side, in particular, receives sufficient cooling. To check the cooling efficiency, measure the surface temperatures of the DE. Regardless of the ambient temperature, this surface temperature must meet the standards listed in Table 3.1. Figure 3.5 shows the temperature measurement point.



**Figure 3.5 Surface temperature measurement points**

**Table 3.1 Surface temperature measurement points and standard values**

No.	Measurement point	Temperature
1	DE cover	60 °C max

### (5) Service area

Figure 3.6 shows how the drive must be accessed (service areas) during and after installation.

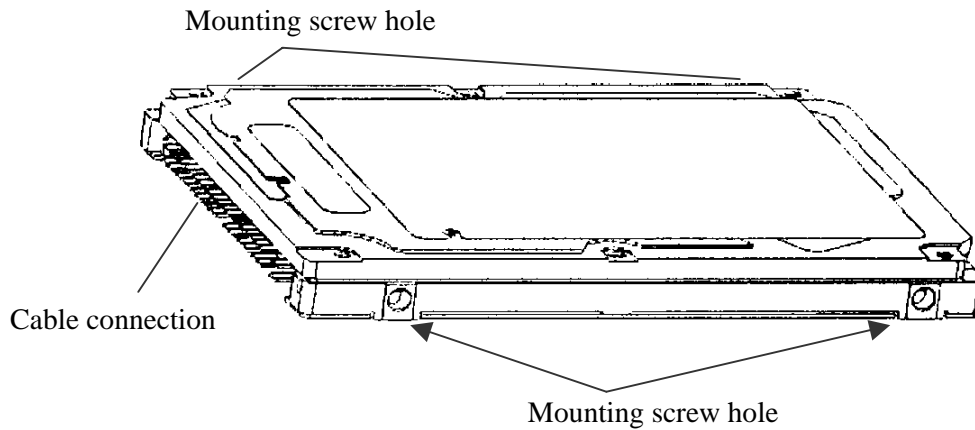

**Figure 3.6 Service area**

### **CAUTION**

**Data corruption:** Avoid mounting the disk drive near strong magnetic sources such as loud speakers. Ensure that the disk drive is not affected by external magnetic fields.

**Damage:** Do not press the cover of the disk drive. Pressing it too hard, the cover and the spindle motor contact, which may cause damage to the disk drive.

**Static:** When handling the device, disconnect the body ground (500 k $\Omega$  or greater). Do not touch the printed circuit board, but hold it by the edges.

### (6) Handling cautions

Please keep the following cautions, and handle the HDD under the safety environment.

- **General notes**

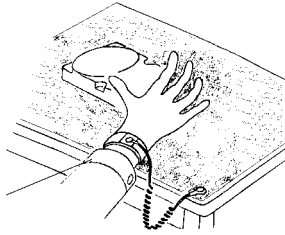

Wrist strap

Use the Wrist strap.

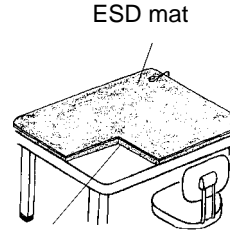

ESD mat

Shock absorbing mat

Place the shock absorbing mat on the operation table, and place ESD mat on it.

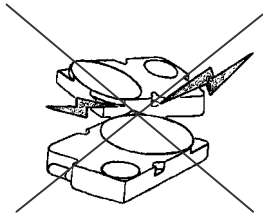

Do not hit HDD each other.

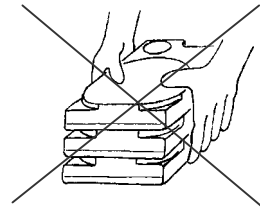

Do not stack when carrying.

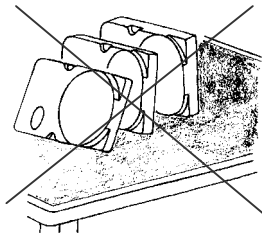

Do not place HDD vertically to avoid falling down.

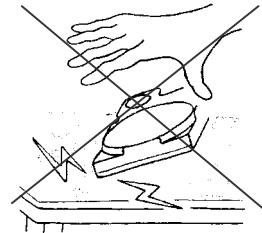

Do not drop.

**Figure 3.7 Handling cautions**

- **Installation**

- (1) Please use the driver of a low impact when you use an electric driver.  
HDD is occasionally damaged by the impact of the driver.
- (2) Please observe the tightening torque of the screw strictly.  
M3 ..... 0.49N·m (5 kgf·cm).

- **Recommended equipments**

	Contents	Model	Maker
ESD	Wrist strap	JX-1200-3056-8	SUMITOMO 3M
	ESD mat	SKY-8A (Color Seiden Mat)	Achilles
Shock	Low shock driver	SS-6500	HIOS



## 3.3 Cable Connections

### 3.3.1 Device connector

The disk drive has the connectors and terminals listed below for connecting external devices. Figure 3.8 shows the locations of these connectors and terminals.

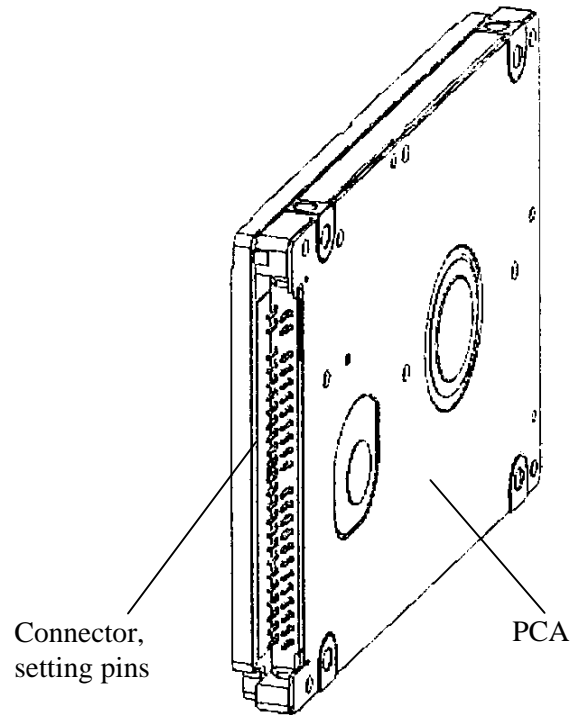

**Figure 3.8 Connector locations**

### 3.3.2 Cable connector specifications

Table 3.2 lists the recommended specifications for the cable connectors.

**Table 3.2 Cable connector specifications**

	Name	Model	Manufacturer
ATA interface and power supply cable (44-pin type)	Cable socket (44-pin type)	89361-144	FCI

**IMPORTANT**

For the host interface cable, use a ribbon cable. A twisted cable or a cable with wires that have become separated from the ribbon may cause crosstalk between signal lines. This is because the interface is designed for ribbon cables and not for cables carrying differential signals.

### 3.3.3 Device connection

Figure 3.9 shows how to connect the devices.

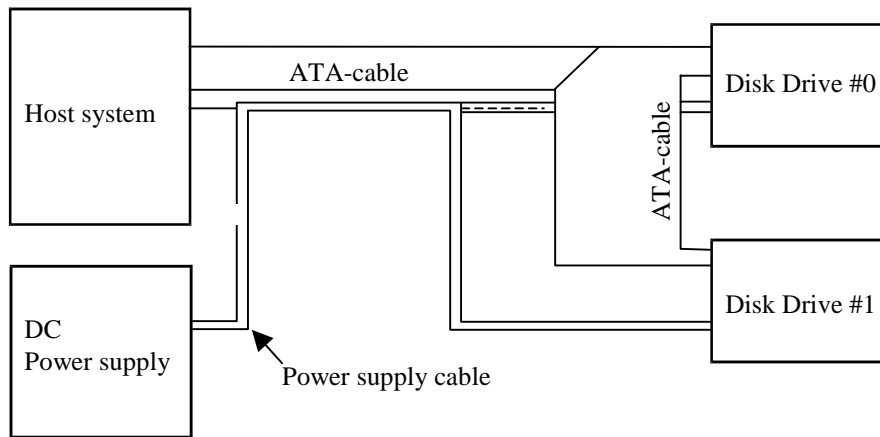

**Figure 3.9 Cable connections**

### 3.3.4 Power supply connector (CN1)

Figure 3.10 shows the pin assignment of the power supply connector (CN1).

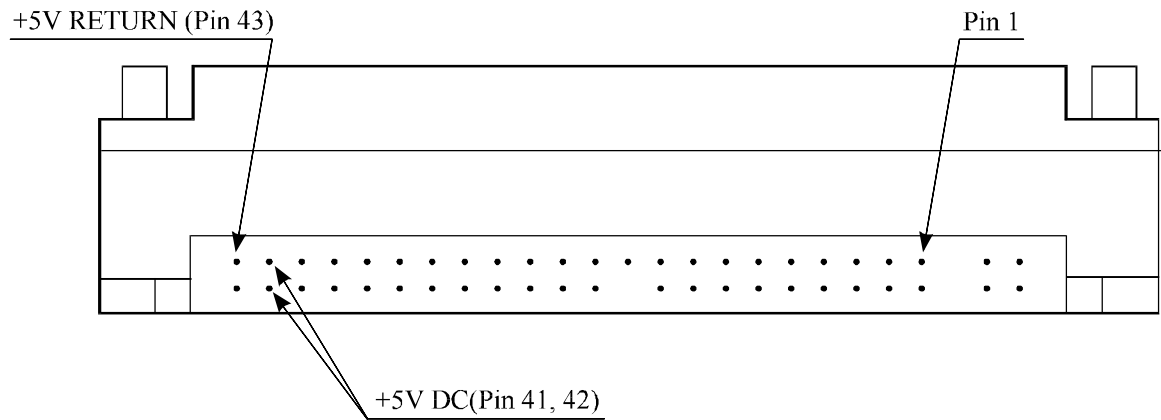

(viewed from connector side)

**Figure 3.10 Power supply connector pins (CN1)**

## 3.4 Jumper Settings

### 3.4.1 Location of setting jumpers

Figure 3.11 shows the location of the jumpers to select drive configuration and functions.

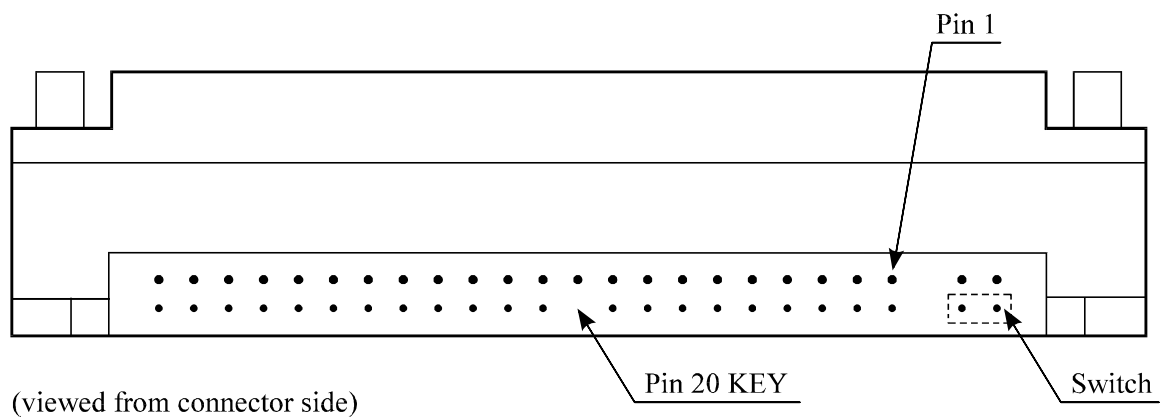

(viewed from connector side)

**Figure 3.11 Jumper location**

### 3.4.2 Factory default setting

Figure 3.12 shows the default setting position at the factory.

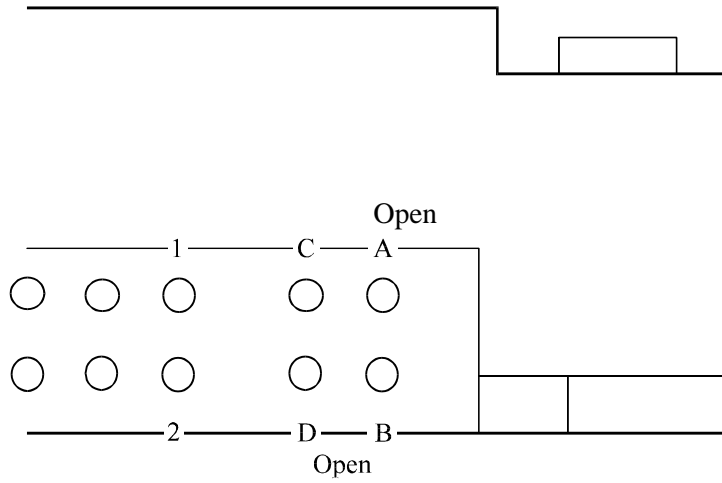

**Figure 3.12 Factory default setting**

### 3.4.3 Master drive-slave drive setting

Master drive (disk drive #0) or slave drive (disk drive #1) is selected.

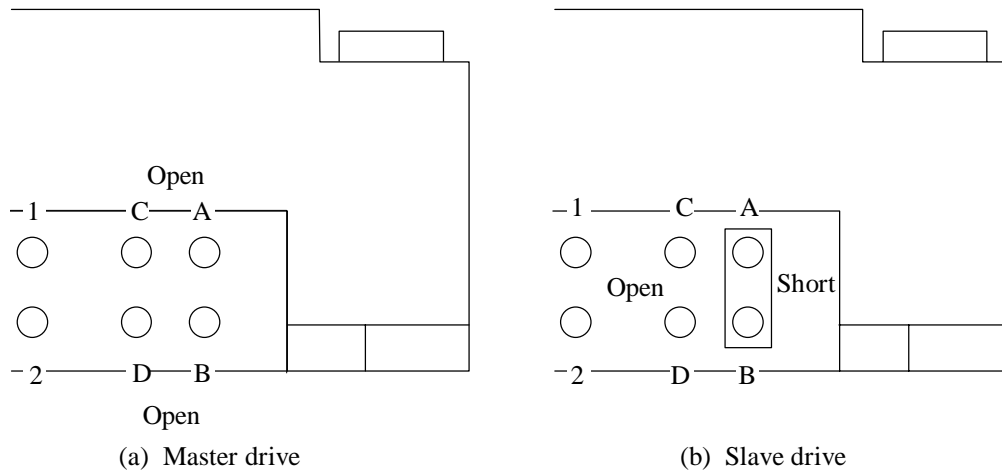

**Figure 3.13 Jumper setting of master or slave drive**

Note:

Pins A and C should be open.

### 3.4.4 CSEL setting

Figure 3.14 shows the cable select (CSEL) setting.

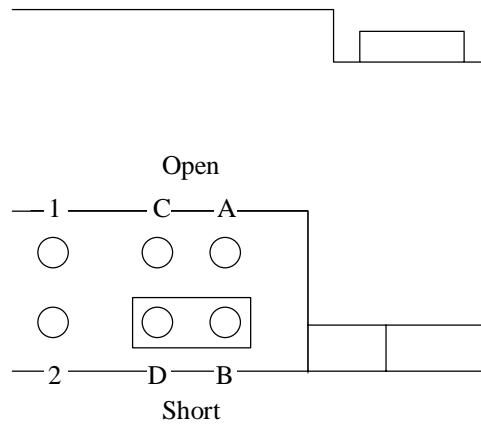

Note:

The CSEL setting is not depended on setting between pins Band D.

**Figure 3.14 CSEL setting**

Figure 3.15 and 3.16 show examples of cable selection using unique interface cables.

By connecting the CSEL of the master drive to the CSEL Line (conductor) of the cable and connecting it to ground further, the CSEL is set to low level. The drive is identified as a master drive. At this time, the CSEL of the slave drive does not have a conductor. Thus, since the slave drive is not connected to the CSEL conductor, the CSEL is set to high level. The drive is identified as a slave drive.

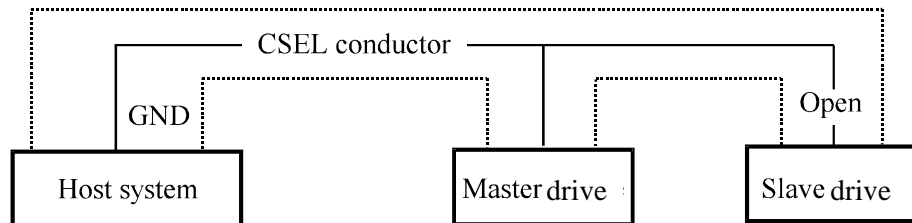

**Figure 3.15 Example (1) of Cable Select**

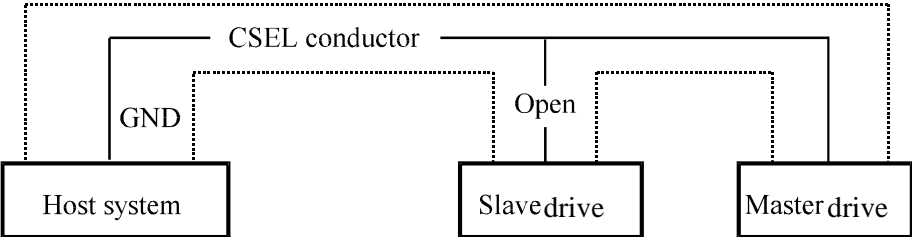

**Figure 3.16 Example (2) of Cable Select**

**3.4.5 Power Up in Standby setting**

When pin C is grounded, the drive does not spin up at power on.