

MB86R11 "Emerald-L"

2D/3D Graphics System-on-a-Chip (SoC) with Integrated GDC and GPU



Description

The MB86R11 "Emerald-L" is a powerful graphics System-on-a-Chip (SoC) with an integrated GDC and GPU. Designed for high-end embedded graphical applications in the automotive market, the MB86R11 "Emerald-L" is well-suited for the most demanding cluster, center information display, navigation and in-car multimedia graphics applications.

At the heart of the Emerald-L SoC are a 400MHz ARM Cortex A9™ processor and a powerful, custom-built graphics core capable of cutting-edge 3D and 2D graphics. The Emerald-L graphics engine is full Open GL ES 2.0-compliant* and builds upon Fujitsu's proven MB86298 "Ruby" technology.

In addition to these primary components, the MB86R11 "Emerald-L" is equipped with multiple peripherals including USB 2.0, Ethernet, Most, IDE66, two ADCs and much more. An on-board DDR2/DDR3-800M controller ensures the high memory bandwidth required for the most demanding embedded applications. The MB86R11 "Emerald-L" packs all these capabilities into a compact 544-ball PBGA package.

The SoC also incorporates many advanced automotive and safety features, including support for the Fujitsu 360° Wrap-Around Video Imaging Technology. A Visibility Enhancement feature performs adjacent pixel comparison to reproduce images with natural colors and great detail. A flexible Signature Unit offers automotive system developers a powerful way to verify data integrity and enhance safety.

Integrated Components

The major functional blocks of MB86R11 “Emerald-L” include:

CPU Core

The MB86R11 “Emerald-L” is powered by a 400MHz ARM Cortex A9™ running at two DMIPS/MHz, which equates to 800 MIPS of processing performance. The ARM processor includes 32kB I-cache, 32kB D-cache, and 128kB L2-cache as well as a Neon DSP.

Graphics Core

Graphics Processor Unit

The MB86R11 “Emerald-L” graphics core is fully OpenGL 2.0 compliant* and features a unified shader array, which supports vertex and fragment shaders. This programmable pipeline allows for OpenGL ES 2.0-compliant graphics. The 16 parallel floating point units are complemented by features including 16- and 32-bit/ pixel color formats, a 32-bit/pixel format frame buffer, and textures that support RGBA, ARGB, and ABGR color ordering.

Since 2D is very efficient at producing many common graphical effects, the shader architecture is complemented by a proprietary, highly optimized 2D core. This 2D engine, which includes Fujitsu’s recently developed PixBlt unit, can process certain graphics without using the GPU. The PixBlt unit offers an extraordinary variety of important functions related to blending, anti-aliasing, and many levels of filtering.

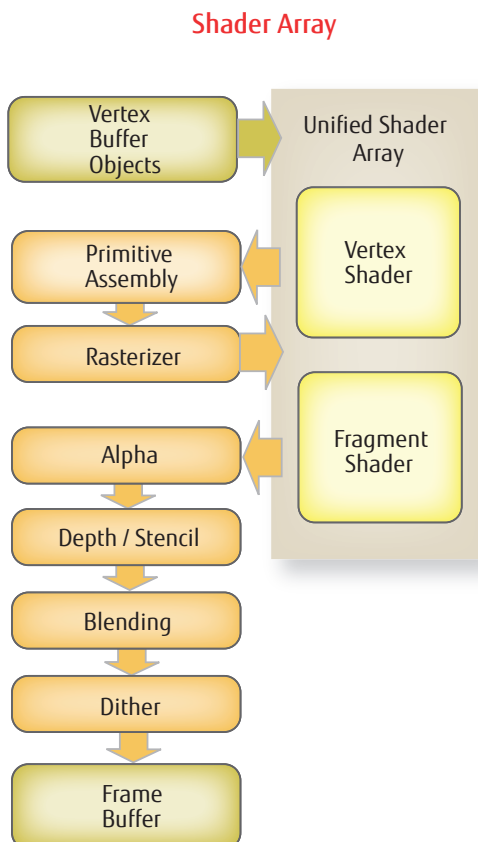

By offloading less complex graphics tasks from the shader array to the 2D engine, the MB86R11 “Emerald-L” design enables superior graphics quality while minimizing processing overhead and memory access. This highly efficient design reduces power consumption and allows the chip to run cooler without the need for active or passive cooling.

MB86R11 “Emerald-L” GPU Features

- Constant fill
- Copy
- Antialiasing (2x2 full scene)
- Simple scaling by repetition or skip
- Blending (OpenGL 2.0 and OpenVG 1.1 modes)
- Logical Raster Operations (ROP2/ROP3)
- 3x3 filtering with OpenVG 1.1 tiling support
- 7x7 filtering support in combination with unified shader

Display Controllers

The MB86R11 “Emerald-L” has three independent display controller units (DCUs). The two main controllers can support up to eight layers and drive display resolutions up to 1600X1200 pixels. These high-performance DCUs are ideal for managing the instrument cluster display and center stack TFT. The third display controller can drive a single-layer display with a maximum resolution of 1024x768@60Hz or 1280x480@60Hz, which is perfect for managing the heads up display. The two main display controllers can drive two displays each, while the third DCU is able to support one, bringing the total number of displays supported by the MB86R11 “Emerald-L” to five.

MB86R11 “Emerald-L” Display Controller Features

- Up to 8 display layers
- Two displays can be connected to each of the two main controllers
- Double buffering
- Alpha plane
- Hardware cursors
- 8-bit, 16-bit and 24-bit color depths supported
- Output in 666 or 888 color
- Hardware scrolling
- Gamma correction and dithering unit
- Graphics “signature” unit for safety-critical applications
- Direct support for dual-view displays

Video Capture Units

The MB86R11 “Emerald-L” supports four independent video-capture inputs. Video can be captured in PAL, NTSC, RGB and 720P HD formats. Powerful visual effects can be created from the captured video by using it as a “texture” for other graphical elements or by enhancing it with overlaid graphics.

MB86R11 “Emerald-L” Video Capture Unit

- ITU R.BT-656 or RGB capture
- Support for 720P (1280x720) HD capture
- Hardware up-scaling and down-scaling
- Adaptive de-interlacing with still image detection
- Horizontal and vertical low-pass filter processing
- Captured video can be used by the texture unit

Memory Controller

The MB86R11 “Emerald-L” supports up to 1GB of 32-bit DDR3-800 or DDR2-800 memory. A unified memory architecture allows seamless access to the memory by the processor core and graphics engine. This enables the MB86R11 “Emerald-L” to provide a maximum memory performance of 3.2GB/sec.

Power Management Unit

A flexible power management unit allows for the selective disabling and enabling of the core to dynamically control power consumption at any given moment. Several low-power “stand-by” modes are also provided, as is an external memory auto-refresh feature.

Interfaces

High-Speed I/O

The MB86R11 “Emerald-L” supports the following high-speed I/O interfaces:

- MediaLB six wire (for MOST 150)
- Ethernet (10/100 Mbit)
- Serial ATA (2 channels)
- Parallel ATA (1 channel)
- NAND/NOR flash engine
- 32-bit external memory bus
- USB 2.0 HS/FS/OTG (4 channels)
- I2S 32-bit audio interface (in / out)
- SD/MMC/SDIO interface (2 channels)

Low-Speed I/O

The MB86R11 “Emerald-L” supports the following low-speed I/O interfaces:

- UART
- CAN
- A/D and D/A converter
- PWM
- SPI
- I²C
- GPIO
- External interrupts

Block Diagram

Emerald-L MB86R11

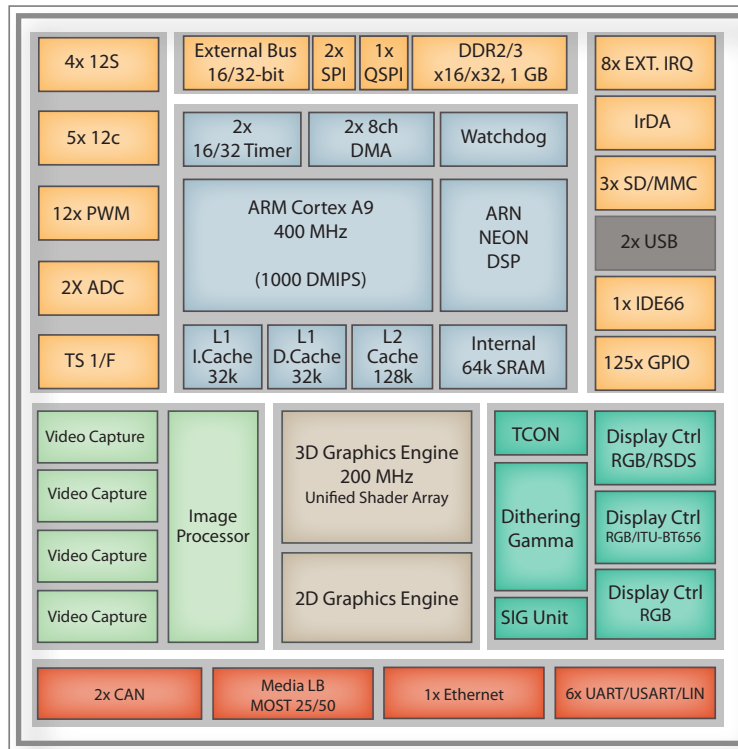

Key Features

- Arm Cortex A9™ processor operating at 400Mhz combined with Fujitsu's cutting-edge display controller (DCU) and OpenGL ES 2.0* shader array.
- High performance DCU drives up to five high resolution displays (1600 X 1200)
- Video Capture unit supports four separate inputs
- Ready for integration with Fujitsu 360° Wrap-Around Video Imaging Technology
- Visibility Enhancement and Object Recognition technology
- DDR2-800/ DDR3/1066 controller supports up to 1GB of graphics memory.
- Broad peripheral support including Most, Ethernet, CAN, and USB (host and device)

* Final certification of conformance with the Open GL ES standard pending verification by Khronos Group (<http://www.khronos.org/opengles/>)

Product information is preliminary and subject to change without notice.

FUJITSU SEMICONDUCTOR AMERICA, INC.

Corporate Headquarters
1250 E. Arques Avenue, M/S 333, Sunnyvale, CA 94085-5401
Tel: (800) 866-8608 Fax: (408) 737-5999
E-mail: FSA_inquiry@us.fujitsu.com | Website: <http://us.fujitsu.com/semi>



©2012 Fujitsu Semiconductor America, Inc.
ARM and Cortex A9 are the trademark of ARM Limited.
All other company and product names are trademarks or registered trademarks of their respective owners.

Printed in the U.S.A. GDC-FS-21388-06/2012