

Case study

Aisin Seiki Co., Ltd.

Aisin Seiki Co., Ltd. refurbished its virtual infrastructures using Fujitsu PRIMERGY blade servers, Fujitsu ETERNUS network disk arrays (NAS), and VMware vSphere virtualization technology. The renewed VMware environment enabled this leading manufacturer to provide cost-optimized infrastructure services across the entire group of companies based on three different SLAs, while significantly reducing TCO to one-third.



The customers

AISIN アイシン精機株式会社

Industry: Manufacturing
 Head office: 2-1, Asahi-machi, Kariya-shi, Aichi, 448-8650 Japan
 Establishment: August 31, 1965
 President: Fumio Fujimori
 Capital: JPY 45.0 billion (as of March 31, 2011)
 Net sales (Consolidated): JPY 2,257.4 billion (as of March, 2011)
 Employees (Consolidated): 74,671
 Number of subsidiaries: 154 (Domestic: 70; Overseas:84)
 Number of affiliates under the equity method: 11 (Domestic: 5; Overseas: 6)
 Company website: <http://www.aisin.com/>
 Business segments: Production and sales of automotive parts, life related products(sewing machines,beds,GHPs) and welfare related products

The challenge

- Refresh the aging previous-generation virtual systems at Aisin Seiki.
- Reduce the burden of maintenance tasks and improve operability of storage systems.

The benefit

- Provided service level-optimized infrastructure services in a cost efficient manner that reduced TCO by two-thirds.
- Adoption of NAS storage ensured ease of storage maintenance and greatly improved operability.

Overview

Aisin Seiki Co., Ltd. (Aisin Seiki), the world's third largest automotive parts manufacturer, built a new virtual environment using Fujitsu PRIMERGY BX920 blade servers, Fujitsu ETERNUS NR1000F NAS storage, and VMware vSphere virtualization technology. It is now able to operate the company's business applications at three different service levels. This made it possible for Aisin Seiki to achieve system optimization and greatly reduce their total cost of IT ownership by two-thirds.

Customer's background

Aisin Seiki needed replacements for the aging infrastructure it had deployed in 2005. The old virtually-consolidated server environment had generated problems from its single-point-of-failure risks.

Aisin Seiki Co., Ltd., one of the leading manufacturers in Japan, was created in 1965 when two Japan-based auto parts makers, Aichi Kogyo Co., Ltd. and Shinkawa Kogyo Co., Ltd. merged to become a single company with a complete range of automotive parts. Since its establishment, the auto parts giant has expanded its business, both domestically and internationally, and kept pace with the worldwide growth of the automotive industry. In addition, with its eye on creating new value and contributing to the prosperity and progress of society, Aisin Seiki has also been expanding its business operations in new fields such as life & amenity and energy systems. To do this it has leveraged the technical capabilities and know-how the company has built throughout its long-standing automotive parts business.

Around 2000, Aisin Seiki embarked on a shift from mainframe computers to x86 servers, for the operation of the company's business-critical applications. By 2004 the number of x86 physical servers at the company had increased to over 150. These covered operations such as data transfers between central hosts and office computers, groupware, email, security, authentication, and other business related functions. As shared-use platforms, the systems were accessed and used not only by Aisin Seiki but also 30 overseas and domestic subsidiaries and affiliates, as well as around 500 suppliers. However, the increased number of physical machines gradually becoming a headache for the company. It led Aisin Seiki to look at adoption of a high availability approach, to increase server uptime. This included – implementation of redundant configurations for critical systems and the separation of production servers from test machines. However, the approach only resulted in further significant

Products and services (Hardware)

- Fujitsu PRIMERGY BX920/RX300 servers
- Fujitsu ETERNUS NR1000F network disk arrays

increases in server volumes. In order to solve the situation, Aisin Seiki looked for ways to improve availability without adding additional boxes. Then in 2005, they saw that VMware virtualization was gaining popularity in enterprise systems. Aisin Seiki decided to implement VMware virtualization solutions to move from its high volumes of servers to a virtually consolidated environment.

“Among the Aisin group of companies, I think Aisin Seiki Co., Ltd. was the first adopter of virtualization, in an attempt to consolidate servers for business-critical applications. The primary reason that we turned to VMware was its capability to support a wide variety of operating systems. That was an important factor, because we had some platforms that were running Windows NT. We chose VMware ESX 2.5



Mr. Ryuichi Aoyama
Manager
Information Systems Dept.
Aisin Seiki Co., Ltd.

when we first implemented VMware, and then upgraded to VMware Infrastructure 3 in 2006. With VMware, over 100 physical servers at Aisin Seiki were virtualized,” recalled Mr. Ryuichi Aoyama, Manager, Information Systems Department at Aisin Seiki Co., Ltd.

The VMware virtualization adoption made it possible for the company to operate “multi-resident” infrastructures instead of sticking with its older “one server per application” approach. This helped Aisin Seiki successfully reduce the number of physical machines. In addition, advanced features such as VMware HA and vMotion delivered dramatically improved system availability, meeting another of the company’s primary needs. However, several storage challenges - continuous availability of the storage systems, and ease of maintenance, remained. As Aisin Seiki was using SAN storage arrays, scheduled interruptions to the whole environment, involving both the SAN storage and servers, were regularly needed when performing firmware updates on the storage and associated devices such as FC switches. Also, the management and maintenance burden of the SAN storage was another area that Aisin Seiki wanted to improve.

Aisin Seiki called upon Fujitsu to refresh their aging virtualization environment.

Fujitsu’s proposal perfectly captured Aisin Seiki’s IT requirements for the support of three different service levels and a switch to NAS storage systems.

When the previously-deployed hardware infrastructures approached their replacement time, Aisin Seiki started working on solving their remaining challenges with SAN storage maintenance. In addition, there were several other new areas to be prioritized. They were: Lower the total cost of IT ownership to help accelerate Aisin Seiki’s corporate-wide cost reduction initiatives after the Lehman shock; Consolidate physically dispersed file servers across many departments; and take system availability to the next level. To address all of these challenges, Aisin Seiki decided on a rebuild of its VMware environment.

Products and services (Software)

- VMware vSphere

For the planned new environment, the company included one specific requirement - the support of multiple service levels. Aisin Seiki’s intention was to operate its business applications at three different service levels, “Gold, Silver and Bronze”. They could then let each business unit select the right service level based on their IT needs and the importance of jobs to be performed. The aim was to reduce overall IT costs with optimized service levels. In solving its storage challenges, the company chose to replace the existing SAN disk arrays with new NAS devices. These would reduce impact on the overall environment during storage-related maintenance work.

“This time, we decided to create the new virtual environment using VMware vSphere. That was a quick decision, as we wanted to continue to use VMware. Also we needed support for Linux operating systems. We also knew that VMware provided the most trusted virtualization platform, and we liked the idea that we could minimize the migration costs by staying with VMware. Besides, considered the fact that we had built a lot of operational know-how and experience over the past 4 years with VMware, it was a natural choice for us,” Mr. Fuyuki Kobayashi, Information Systems Department at Aisin Seiki Co., Ltd. talks about the benefits of using VMware.

For the hardware platforms, Fujitsu PRIMERGY BX920 blade servers and Fujitsu ETERNUS NR1000F network disk arrays were chosen to provide the core foundation for building the virtual environment. Aisin Seiki turned to Fujitsu, as the company was pleased with Fujitsu’s efforts to come up with a best-fit offering that could deliver maximum cost savings and support Aisin Seiki’s operation of a new environment concept, with three ‘fine-tuned’ service levels. Mr. Ikuya Nonoyama, System Management Group, DC Services Department, Datacenter Business Unit at Aisin Infotex Co., Ltd., the company responsible for providing IT services to Aisin Seiki and its group of companies, recalls the time when Aisin received proposals for the tech refresh project. “We called on several vendors for help, but only Fujitsu lived up to our expectations. The truth was all the other vendors came back with a variety of proposals, but they were all based on the highest-possible specifications that would meet the ‘Gold-level’ of service needs. Those vendors then tried to provide their offerings at a discount price to suit our budget. Such approaches were a bit different from what we had sought. When we looked at those offerings from a total cost viewpoint, including running costs, we had to conclude each proposal would not provide what we needed. In contrast, the proposed configuration from Fujitsu included three well-defined service levels, based on the existing applications that we used at Aisin Seiki, as well as optimized pricing based on lowering the overall costs required for the new environment. That was a perfect proposal, and we were impressed,” continues Nonoyama.



Mr. Fuyuki Kobayashi
Information Systems Dept.
Aisin Seiki Co., Ltd.

Once the hardware configuration was determined, Aisin Seiki

the phase of checking its applications inventory. During that process, all business applications used throughout the company were thoroughly reviewed, and each allocated under Gold, Silver or Bronze, so that the individual applications would operate at the right service levels in the future. Through that careful inventory check, Aisin Seiki discovered that, among the company's existing applications, 53% were over specification while 17% were under specification. In fact, only 30% of the total systems had right-sized specifications. Those findings helped the company allocate its business applications to the appropriate service level and correct the unmatched specification problems. It also indicated the areas where the company could reduce costs. In July 2010, immediately after the applications inventory process,



Mr. Ikuya Nonoyama
System Management Group
DC Services Dept.
Datacenter Business Unit
Aisin Infotex Co., Ltd.

migration to the new vSphere-based environment began. As the systems were moved from the old to new environments, Aisin Seiki could only allow a maximum of one day's system downtime for each. The company has therefore initially projected that a relatively long lead-time would be required to complete the task, and planned migration completion by the end of December 2010, a 5 month period. "Regarding the actual migration work, Fujitsu carried out those tasks for us. Fujitsu quickly got on with the migration tasks using VMware vCenter Converter. When possible, as many as 10 systems were moved to the new environment in a single day. Thankfully, things went so well, that the migration work was completed by the end of October - two months earlier than we expected," says Kobayashi.

The newly-deployed virtual environment at Aisin Seiki
Refurbished virtual environment lets Aisin Seiki operate its business-critical systems and file servers with greatly improved maintainability.

Aisin Seiki's new environment was constructed using Fujitsu hardware platforms and VMware vSphere. At the center, 18 Fujitsu PRIMERGY BX920 server blades are connected to the Fujitsu ETERNUS NR1000F network disk arrays. A PRIMERGY RX300 rack-mounted server is used to manage and backup the virtual environment (Figure 1). Of the 18 PRIMERGY blade servers, 10 blades host 60 virtual machines (VMs) dedicated to running Gold-service-level applications. Five blades host 40 VMs which are used for Silver-level services, and the remaining three blades are allocated as shared-use file servers and operated at Bronze service level. For storage, Aisin Seiki chose to adopt Fujitsu ETERNUS NR1000F in a clustered configuration to ensure continuous availability. Using the NAS disk arrays, it is possible to recover data on a per-file basis. This allows the company to be very responsive to end-user requests for data recovery. In addition, switching from SAN storage to the NAS-based system made the storage maintenance work much easier for Aisin Seiki. With the responsiveness, easier operation, and reliable performance, of the new NAS storage Aisin Seiki now has an ideal storage environment.

Nonoyama says, "In the event a problem occurs with storage, Fujitsu provides us with troubleshooting support for individual problems based on the level of failure. For example, if a problem occurs, Fujitsu provides maintenance patches only for the affected areas. We appreciate such thoughtful and granular support from Fujitsu, as it

entered really helps us ensure high levels of system maintainability for the overall virtual environment."

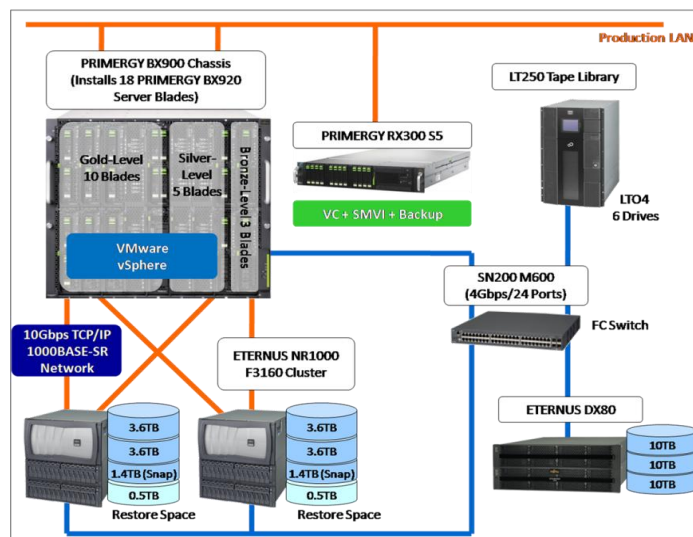

(Figure 1) System Configuration at Aisin Seiki

Business benefits and future scenarios

The new virtual environment is positioned to deliver higher service levels than physical server environments. Aisin Seiki has system expansion plans to consolidate and integrate the company's manufacturing, engineering and overseas infrastructures into the vSphere environment.

The implementation of the new virtual environment with Gold, Silver and Bronze service levels not only delivered TCO reductions for the company, it also allowed Aisin Seiki to establish a cost-optimized charging scheme. Now each business unit can use the infrastructure services and pay for them in line with their level of IT needs. This further helps reduce overall IT costs at the company.

"When we first adopted VMware virtualization technology in 2005, our primary goal was to create a server consolidation environment to reduce the volume of physical servers. After years of experience with VMware virtualization since then, we've found that virtualization can actually contribute not only to successful server consolidation but also greatly improve system availability. With advanced high availability features such as VMware HA and vMotion available in our new virtual environment, we can position the new vSphere-based systems to meet higher service levels than our conventional physical environments. I think this may seem to be completely paradoxical to what many other enterprise IT departments today think about the concept of virtualization," says Mr. Aoyama.

Accordingly, it has become mandatory at Aisin Seiki that for each new system added and deployed, the systems infrastructure department must be involved from the very beginning. This allows determination, right from the initial system planning phase, whether a virtualization approach should be implemented for the planned system.

With Aisin Seiki in the process of aggressive business expansion into the global marketplace, the company is now planning to expand further the scope of its virtualization targets. Aisin Seiki is considering enabling use and access to the new virtual environment from overseas

Case study Aisin Seiki Co., Ltd.

subsidiaries via networks as well as deploying virtual environments locally at overseas subsidiaries. This would allow them to roll out the same system environments inside and outside of Japan. Aisin Seiki is enthusiastic about fully leveraging the advantages delivered by the recently refurbished virtualization environment in growing its business.

In collaboration with

vmware[®]

Contact

FUJITSU Limited
Address: 1-5-2
Higashi-Shimbashi,
Minato-ku, Tokyo 105-7123
JAPAN
Website: www.fujitsu.com
2011-07-12-JP-EN

© Copyright 2011 Fujitsu Limited, Fujitsu, the Fujitsu logo are trademarks or registered trademarks of Fujitsu Limited in Japan and other countries. Other company, product and service names may be trademarks or registered trademarks of their respective owners. Technical data subject to modification and delivery subject to availability. Any liability that the data and illustrations are complete, actual or correct is excluded. Designations may be trademarks and/or copyrights of the respective manufacturer, the use of which by third parties for their own purposes may infringe the rights of such owner.