

Areas Covered

Before Reading This Manual	This section explains the notes for your safety and conventions used in this manual.
Chapter 1 Overview	This chapter explains component names and basic operations of this server, as well as an overview of the software provided with this server. In addition, the workflow, from placing the server to starting the operation, is also described.
Chapter 2 Checking before OS Installation	This chapter explains the preparation and cautions for the server before OS installation. Observe this chapter before starting installation.
Chapter 3 OS Installation	This chapter explains how to install the OS in the server using ServerStart.
Chapter 4 Operations after OS Installation	This chapter explains the operations to be performed after OS installation. Be sure to perform these operations before operating the server.
Chapter 5 High Reliability Tools	For stable PRIMERGY server operations, we recommend that high reliability tools be installed. This chapter explains the installation and necessary settings of high reliability tools.
Chapter 6 Installing Internal Options	This chapter explains how to install and remove the various hardware options.
Chapter 7 Configuring Hardware and Utilities	This chapter explains how to make the environment settings necessary to operate the server and how to use each utility.
Chapter 8 Operation and Maintenance	This chapter explains the operations that become necessary after starting to use this server as well as daily care and maintenance.
Appendix	This appendix explains the specifications for the server and for its internal options.

Before Reading This Manual

For Your Safety...

This manual contains important information, required to operate the server safely. Thoroughly review the information in this manual before using the server. Especially note the points under "Safety Precautions", and only operate the server with a complete understanding of the material provided. This manual and "Safety Precautions" should be kept in an easy-to-access location for quick reference when using this server.

Safety of Laser

This product contains Class 1 laser product, which is compatible with U.S. FDA 21 CFR, Subchapter J and International Standard IEC 60825-1. Do not look at the light source of laser beam directly. Doing so may lead to visual damage.

Data Backup

To protect data stored in this device (including basic software and application software), perform backup and other necessary operations. Note that data protection is not guaranteed when repairs are performed. It is the customer's responsibility to maintain backup copies in advance.

In case of data loss, Fujitsu assumes no liability for data maintenance or restoration and damages that occur as a result of the data loss for any reason, except for items covered under warranty.

High Safety

The Products are designed, developed and manufactured as contemplated or general use, including without limitation, general office use, personal use, household use, and ordinary industrial use, but are not designed, developed and manufactured as contemplated for use accompanying fatal risks or dangers that, unless extremely high safety is secured, could lead directly to death, personal injury, severe physical damage, or other loss (hereinafter "High Safety Required Use"), including without limitation, nuclear reaction control in nuclear facility, aircraft flight control, air traffic control, mass transport control, medical life support system, missile launch control in weapon system. You shall not use this Product without securing the sufficient safety required for the High Safety Required Use. If you wish to use this Product for High Safety Required Use, please consult with our sales representatives in charge before such use.

Problems may occur with this device in the event of an instantaneous voltage drop of the power supply due to lightning, etc. To prevent an instantaneous voltage drop of the power supply, we recommend that you use an uninterruptible power supply system.

■ Usage of this server

This server is designed to be used about eight hours per day for five years with small scale and comparatively low access frequency. Refrain from using for mission-critical tasks in which continuous 24/7/365 operation is necessary, or database in which the access is frequently repeated, and high reliability is required.

To prevent the loss of important data, regular data backup is recommended.

■ Trademarks

Microsoft, Windows, and Windows Server are trademarks or registered trademarks of Microsoft Corporation in the USA and other countries.

Intel, Pentium, Celeron and Xeon are registered trademarks or trademarks of Intel Corporation or its subsidiaries in the USA and other countries.

Linux is a trademark or registered trademark of Linus Torvalds in the USA and other countries.

Red Hat and all Red Hat-based trademarks and logos are trademarks or registered trademarks of Red Hat, Inc. in the USA and other countries.

Other product names used are trademarks or registered trademarks of their respective manufacturers.

Other products are copyrights of their respective manufacturers.



All Rights Reserved, Copyright© FUJITSU LIMITED 2008

Screen shot(s) reprinted with permission from Microsoft Corporation.



Remarks

■ Warning descriptions

Various symbols are used throughout this manual. These are used to emphasize important points for your safety and that of others. The following are the symbols and their meanings. Fully understand these symbols when reading this manual.



 WARNING	Failure to observe this warning may cause serious injury or death, and/or destroy the system.
 CAUTION	Failure to observe this warning may lead to injury, destruction of the system, or loss of data.

The following symbols are used to indicate the type of warning or caution being described.

	A triangle mark emphasizes the urgency of the WARNING and CAUTION. Details are described next to the triangle.
	A barred circle (⊘) warns against certain actions (Do Not). Details are described next to the circle.
	A black circle indicates actions that must be taken. Details are described next to the black circle.

■ Symbols

Symbols used in this manual have the following meanings.

 IMPORTANT	These sections explain prohibited actions and points to note when using this device. Make sure to read these sections.
 POINT	These sections explain information needed to operate the hardware and software properly. Make sure to read these sections.
→	This mark indicates reference pages or manuals.

■ Key descriptions / operations

Keys are represented throughout this manual in the following manner.

E.g.: [Ctrl] key, [Enter] key, [→] key, etc.

The following indicate pressing several keys at once:

E.g.: [Ctrl] + [F3] key, [Shift] + [↑] key, etc.

■ DVD-ROM drive description

DVD-ROM drive is described as "CD/DVD drive" herein.

■ Entering commands (Keys)

Command entries are displayed in the following way.

```
diskcopy a: a:
          ↑ ↑
```

- At each blank in a command line (as pointed out above), press the [Space] key once.
- When using Windows or DOS OS, commands are not case sensitive.
- CD/DVD drive names are shown as [CD/DVD drive]. Enter your drive name according to your environment.

```
[CD/DVD drive]:\setup.exe
```

■ Screen shots and figures

Screen shots and figures are used as visual aids throughout this manual. Windows, screens, and file names may vary depending on the OS, software, or configuration of the server used. Figures in this manual may not show cables that are actually connected for convenience of explanation.

■ Consecutive operations

Consecutive operations are described by connecting them with "-".

Example: Procedure of clicking the [Start] button, pointing to [All Programs], and clicking [Accessories]

↓

Click [Start] – [All Programs] – [Accessories].

■ Server type

Server type is described as follow.

table: Server type

Type	Expression and abbreviation
Server without an internal hard disk	Diskless type

■ Abbreviations

The following expressions and abbreviations are used throughout this manual.

table: Abbreviations of product names

Product name	Expressions and abbreviations		
PRIMERGY ECONEL 100 S2	ECONEL 100 S2 or the server		
Microsoft® Windows Server® 2003, Standard Edition	Windows Server 2003	Windows	
Microsoft® Windows Server® 2003 R2, Standard Edition	Windows Server 2003 R2		
Microsoft® Windows Server® 2003, Standard x64 Edition	Windows Server 2003 x64 *1		
Microsoft® Windows Server® 2003 R2, Standard x64 Edition	Windows Server 2003 R2 x64		
Microsoft® Windows® Small Business Server 2003	SBS 2003 *1		
Microsoft® Windows® Small Business Server 2003 R2	SBS 2003 R2		
Microsoft® Windows® 2000 Server	Windows 2000 Server		
Microsoft® Windows® Preinstallation Environment	Windows PE		
Microsoft® Windows Vista® Business	Windows Vista		
Microsoft® Windows® XP Professional	Windows XP Professional		
Microsoft® Windows® 2000 Professional	Windows 2000 Professional		
Microsoft® Windows Server® 2003 Service Pack	Service Pack		
Microsoft® Windows Server® 2003 x64 Service Pack			
Red Hat Enterprise Linux ES (v.4 for x86)	Linux		
Red Hat Enterprise Linux ES (v.4 for EM64T)			
Red Hat Enterprise Linux 5 (for x86)			
Red Hat Enterprise Linux 5 (for Intel64)			

*1: Unless otherwise noted, Windows Server 2003 x64 and SBS 2003 can also mean Windows Server 2003.

Reference Information

■ Software manuals

Software Manual contains other reference information and cautions for ServerStart not described in this manual. Please read it before using ServerStart.

Software Manual is contained as a "README.TXT" file in the root directory on PRIMERGY Startup Disc. Use a text editor to read it.

■ Latest information about software provided with this server

For the latest information regarding ServerStart and other software provided with this server, refer to the Fujitsu PRIMERGY website (<http://primergy.fujitsu.com>).

Warning and Caution Labels

Warning and caution labels are found on the server.

Do not remove or stain these labels.

Contents

Chapter 1 Overview

1.1 ECONEL 100 S2	12
1.2 Supplied Software	14
1.2.1 Setup Support Tool - ServerStart	14
1.2.2 High Reliability Tools	18
1.2.3 Installing High Reliability Tools	19
1.3 Component Names and Functions	21
1.3.1 Server (front view)	21
1.3.2 Server (rear view)	23
1.3.3 Server (internal)	25
1.3.4 Baseboard	26
1.4 Standard Operations	28
1.4.1 Turning On the Server	28
1.4.2 Turning Off the Server	29
1.4.3 Inserting and Ejecting a Floppy Disk	31
1.4.4 Inserting and Ejecting a CD/DVD	33
1.5 Workflow	35

Chapter 2 Checking before OS Installation

2.1 Preparation on the Server	38
2.1.1 Installing Internal Options	38
2.1.2 Hardware Settings	40
2.2 Selecting an Installation Method	41
2.2.1 Supported OS	41
2.2.2 Installation Modes of ServerStart	41
2.3 Precautions on Installation	42
2.3.1 Installation Partition Size	42
2.3.2 Notes on Configuring RAID	42
2.3.3 Cautions for Using ServerStart	43
2.3.4 Automatic Driver Installation with ServerStart	45

Chapter 3 OS Installation

3.1 Quick Installation Mode	48
3.2 Expert Mode	54
3.2.1 Starting Up the Expert Mode	54
3.2.2 Disk Manager	58
3.2.3 OS Installation Wizard	59
3.2.4 Application Wizard	64
3.2.5 Starting OS Installation	65

Chapter 4 Operations after OS Installation

4.1 Memory Dump/Paging File Setting	70
4.1.1 How to Obtain Memory Dump	70
4.2 Creating a Disk for System Recovery	75
4.2.1 Creating the Automated System Recovery (ASR) Set	75
4.3 Storing the System Configuration Information	77
4.3.1 Storing the BIOS Information	78
4.3.2 Recovering the BIOS Information	79
4.4 Creating Maintenance Tools and Driver Disks	80
4.4.1 Installing ServerStart	80
4.4.2 Startup Method for FloppyBuilder	83
4.4.3 Creating "Server Management Tools" Disk	85
4.4.4 Creating Driver Disks	86
4.4.5 Creating a DOS Diskette	86
4.5 Notes before Operating the Server	87
4.5.1 Auto-run Function from CD/DVD Drives	87
4.5.2 Drive Letter Assignment in the Expert Mode	87
4.5.3 Notes on Advanced Uninterruptible Power Supply (UPS)	88
4.5.4 Turning the Power On via a LAN	89
4.5.5 Other Notes on Operation	89
4.6 LAN Driver Advanced Setup [Intel® PROSet]	90
4.6.1 Intel® PROSet Installation	90
4.6.2 VLAN	91

Chapter 5 High Reliability Tools

5.1 RAID Management Tool	94
5.2 Server Monitoring Tool [ServerView]	95
5.2.1 Installing ServerView	96
5.2.2 Setting Required after Installation	96
5.3 Maintenance Support Tool [HRM/server]	97
5.3.1 Installing HRM/server	97
5.3.2 How to Use	97
5.4 Solving Problems Early [DSNAP]	98
5.4.1 Installing DSNAP	98
5.4.2 How to Use	98

Chapter 6 Installing Internal Options

6.1 Before Installing Internal Options	100
6.2 Removing and Attaching Covers	102
6.2.1 Removing Covers	102
6.3 Installing Memory Modules	104
6.3.1 Installation Location of Memory Modules	105

6.3.2 Installable Memory Modules and Notes	105
6.3.3 How to Install Memory Modules	106
6.4 Installing Expansion Cards	108
6.4.1 Installation Location of Expansion Cards	108
6.4.2 Installable Expansion Cards and Notes	109
6.4.3 How to Install Expansion Cards	109
6.4.4 When a SAS Array Controller Card is Installed	112
6.5 Installing Internal Hard Disk Units	115
6.5.1 Installation Location of Internal Hard Disk Units	116
6.5.2 Installable Internal Hard Disk Units and Notes	116
6.5.3 How to Install Internal the Hard Disk Units	117
6.6 Installing 5-inch Internal Options	121
6.6.1 Installation Location of 5-inch Internal Devices	121
6.6.2 Installable 5-inch Internal Devices	122
6.6.3 How to install 5-inch Internal Devices	122

Chapter 7 Configuring Hardware and Utilities

7.1 Jumper Settings	126
7.2 BIOS Setup Utility	127
7.2.1 Starting and Exiting BIOS Setup Utility	127
7.2.2 Main Menu	130
7.2.3 Boot Features Submenu	131
7.2.4 Advanced Menu	132
7.2.5 Peripheral Configuration Submenu	133
7.2.6 Advanced System Configuration Submenu	134
7.2.7 Advanced Processor Options Submenu	135
7.2.8 PCI Configuration Submenu	136
7.2.9 System Management Submenu	137
7.2.10 Security Menu	138
7.2.11 Power Menu	140
7.2.12 Boot Menu	141
7.2.13 Exit Menu	142

Chapter 8 Operation and Maintenance

8.1 Daily Maintenance	144
8.1.1 Checking the Server Status	144
8.1.2 Cleaning	144
8.2 Troubleshooting	148
8.2.1 Hardware Troubleshooting	148
8.2.2 Error Messages	150
8.2.3 Software Troubleshooting	155
8.3 System Event Log	160
8.3.1 How to Refer to Event Logs	160

8.3.2 Deleting the System Event Log	160
8.4 Security	161
8.4.1 Hardware Security	161
8.4.2 Security against Unauthorized Use	161
8.4.3 Security When Disposing of the Server	163
8.5 Backup	164
8.5.1 Importance of Backups	164
8.5.2 Backup Devices, Software and Their Operations	164
8.6 Restoring the System	167
8.6.1 For Windows Server 2003	167
8.7 Reinstalling the OS	169
8.7.1 Checking before OS Reinstallation	169
8.8 Maintenance Service	170
8.8.1 Contacting Maintenance Support	170

Appendix

A Server Specifications	172
B Specifications for Internal Options	174
B.1 Memory	174
B.2 Internal Hard Disk Units	174
B.3 Parallel Port Option	175
B.4 Power Cord Selection	175
C Setting Notifications for Events of Failures	177
C.1 Setting for Alarm Group	177
C.2 Setting Actions	181
D Recycling	192

Chapter 1

Overview

1

This chapter explains component names and basic operations of this server, as well as an overview of the software provided with this server. In addition, the workflow, from placing the server to starting the operation, is also described.

1.1	ECONEL 100 S2	12
1.2	Supplied Software	14
1.3	Component Names and Functions	21
1.4	Standard Operations	28
1.5	Workflow	35

1.1 ECONEL 100 S2

This server is an economy server with high-speed processing and cost-effectiveness, having the following features.

■ High reliability

● Memory modules enabling high-speed processing

This server supports the memory modules, DDR2-800 Unbuffered ECC DIMM, enabling high-speed processing.

● Disk array configuration

An array can be configured with an Onboard Software RAID (Embedded MegaRAID SATA). An array can also be configured with an optional SAS array controller card (MegaRAID SAS) installed.

● Data security

This server provides data securities to prevent such problems as data asset theft by setting a password in BIOS Setup Utility.

● Proactive fan function

Stable system operation is performed with automatically increasing the rotating speed of the system fan to control temperature in the server as a fan fails or the ambient temperature rises.

● High reliability tools

High reliability tools, such as ServerView which is the tool for monitoring the server status, offer further stable system operation. Refer to "1.2.2 High Reliability Tools" (→pg.18) for details.

■ High-speed processing

● Intel® Pentium® Dual-Core Processor and Celeron® Processor

An Intel® Pentium® Dual-Core Processor, or a Celeron® processor is installed as a standard feature, which enables high-speed data processing. The Pentium® Dual-Core Processor has the same operational capacity as two CPUs, enabling high-speed processing.

■ Excellent scalability

● Maximum 8GB memory size

This server has 512MB memory installed as a standard feature. The memory size can be extended to 8GB maximum.

- **Four hard disk bays**

Up to four hard disk units of 500GB maximum capacity can be installed in this server.

- **Four PCI slots**

The server has four PCI slots. Functions can be expanded by using expansion cards.

- **5-inch internal option bay**

The server has a 5-inch storage bay, and a 5-inch internal device option can be installed to accommodate increasing data.

- **Sound deadening characteristics**

This server has the sound deadening characteristics. The characteristics offer you a less stress environment even in an office by reducing the operational noise to nearly 20dB.

1.2 Supplied Software

The following software is supplied together with the server. ServerStart supports setting up the system and high reliability tools to prevent troubles while server system is running.

1.2.1 Setup Support Tool - ServerStart

ServerStart is an initial setup support tool for PRIMERGY. It offers simple procedures for setup and proper installation for recommended drivers.

■ Setting up with ServerStart

When performing the OS installation with ServerStart, drivers which are corresponding to the automatically recognized expansion cards will be installed by ServerStart. In addition, high reliability tools and array controller management tools are automatically installed. It prevents the related errors. It is recommended to perform the OS installation by using ServerStart.

Not using ServerStart

- Complicated hardware settings such as RAID configuration
- User definition, access policies and network settings
- Manual settings for each item
resulting in leading mistakes and taking time for server installation.

Example:
IP address settings, creation of user,
registration of computer name, and etc.

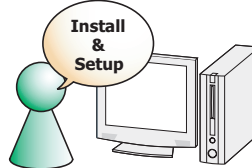

Using ServerStart

- Automatic RAID configuration
- Automatic installation of recommended drivers
- Automatic installation of high reliability tools are available.

Example:
Automated operations such as OS installation.

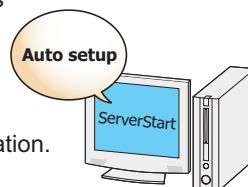

POINT

- ▶ Some operations such as a license window and media replacements are required to be performed manually.
- ▶ High reliability tools are software with comprehensive strength for stable system operation of the server management.

■ Merit with ServerStart setup**● Network configuration**

ServerStart can configure a network on server installation. For details on available network patterns, refer to "Using ServerStart to Configure the Network".

● Automatic driver installation

Recommended drivers for automatically recognized expansion cards are installed with the server. This prevents possible mistakes in driver installation, such as installation of an older version or drivers which were not supplied with this server.

● Automatic RAID configuration

Even without RAID utility, a disk array can be configured by specifying a RAID type and number of hard disk units.

■ Intuitive user interface

The intuitive user interface allows you to easily set the necessary information.

● Main window

When ServerStart starts up, the following window appears. The window and tool bar differ, depending on the mode.

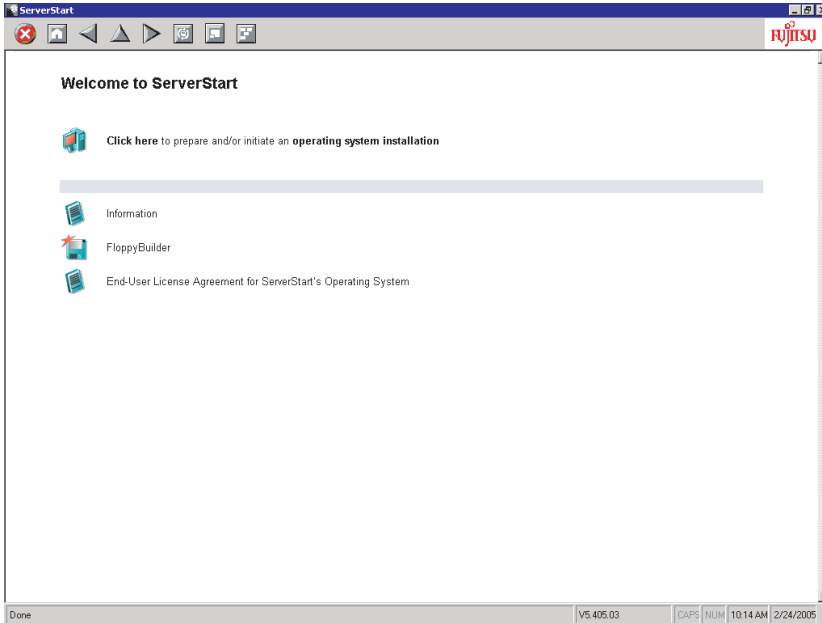

● Tool bar

For the Expert mode

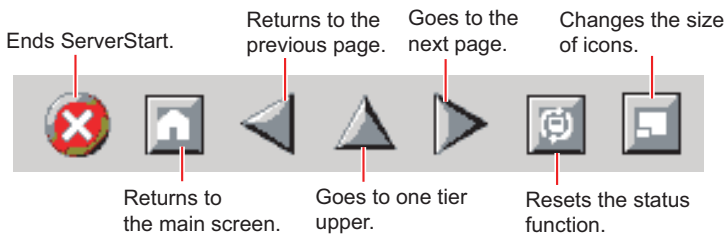

IMPORTANT

- ▶ While the wizard is running, do not click the  icon to move to the previous or next window or to upper tree level. To move to a different window, click the [Previous], [Up], or [Next] button at the bottom of the wizard window.

● **Wizard window**

Clicking a wizard displays a wizard window.

Set each item in the wizard window. To move to a step in the next wizard window, click the operation button at the bottom of the window. Clicking [help] displays an explanation for setting the item.

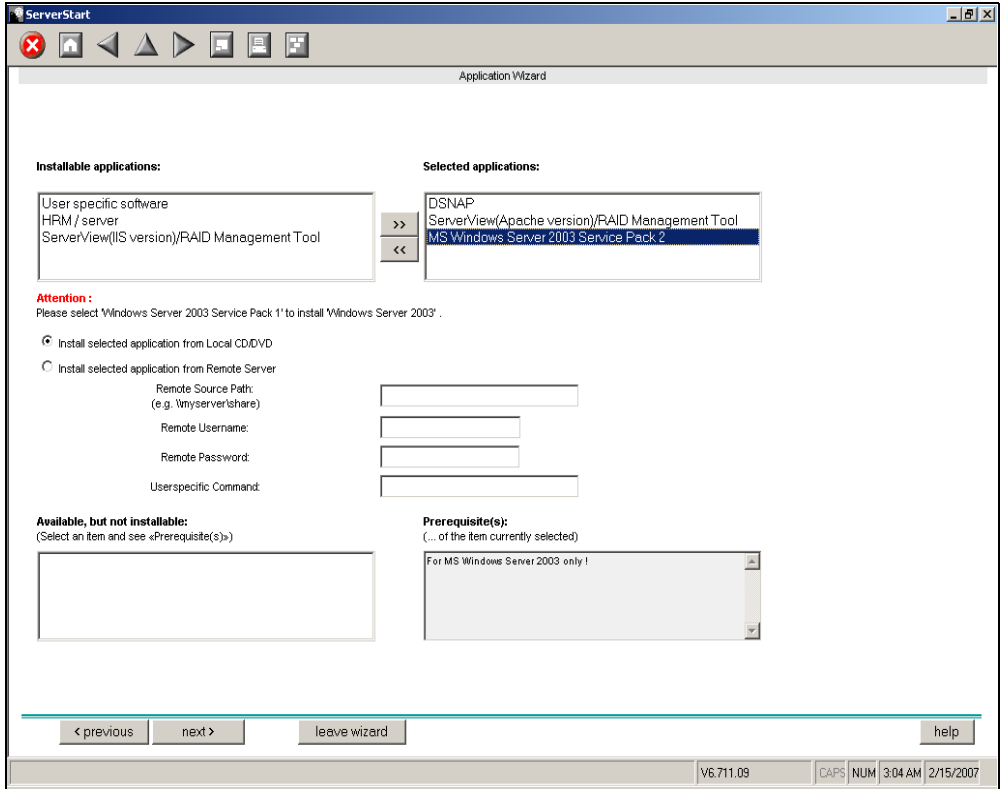

1.2.2 High Reliability Tools

High reliability tools provide comprehensive supports for stable system operations of the server. The following tools have individual management function through normal operations to restoration from errors:

- Server monitoring tools
- System diagnosis support tool
- LAN driver advanced setup tool

■ Server monitoring tools

The server monitoring tools monitor the hardware status and notify the event of an error when irregular status occurs.

● Early detection of a server failure [ServerView]

ServerView monitors the server status to protect important server resources. The server hardware keeps under observation all the time and a potential irregular status will be notified in a timely manner when it is detected. A corrective action can be taken in early stage and eliminate the system error before growing a serious matter.



- ▶ For notes of security for ServerView, refer to " ● Security" in Section "1.1.7 Note" in "ServerView User's Guide."

● Maintenance support tool [HRM/server]

HRM/server performs the server maintenance operation promptly and surely to retain stable system operation.

● Early detection of a disk problem [RAID management tool]

RAID management tool monitors a configured disk array performance. When an event occurs, it leaves an event log in the event viewer's application logs. At the same time, a pop-up window indicates a hard disk failure, rebuild status, etc.



Notification settings for events of failures

- ▶ This server is not equipped with LEDs which notify you an error or a failure of the installed hard disk units. To receive an error or a failure notification in real-time, start up ServerView S2 to complete the necessary settings after installation of ServerView and RAID management tool (ServerView RAID). For details on the setting procedures, refer to "Appendix C Setting Notifications for Events of Failures" (→pg.177).

■ System diagnosis support tool

The system diagnosis support tools boost device management in order to perform stable server operation.

● Early solution to problems [DSNAP]

DSNAP is a command line utility for collectively acquiring failure analysis information. Command line operation makes easy to set the configuration information of the system file and major registries, and collect the event log.

When a problem occurs in your Windows Server 2003 system, DSNAP is used for a support engineer to understand your system software configuration and settings correctly and to promote research smoothly. Provide this with memory dump to your support engineer.

■ LAN driver advanced setup tool

This tool sets details on the LAN, including VLAN configuration.

● Intel® PROSet

Intel® PROSet is a tool to set details of LAN cards to configure VLAN with LAN cards.

1.2.3 Installing High Reliability Tools

Collective installation of all high reliability tools, provided with PRIMERGY, may be made by specifying them in "Application Wizard".

The following high reliability tools are installed with ServerStart.

table: High reliability tools installation

High reliability tool	ServerStart installation	
	Quick Installation mode	Expert mode
RAID Management Tool / ServerView (for Apache)	I	S
RAID Management Tool / ServerView (for IIS)	M	N
HRM/server	I	N
DSNAP	I	S
Intel® PROSet	I	I

I : Installed automatically

N: Installed if selected (Not selected by default)

S: Installed if selected (Selected by default)

M: Install manually.



- ▶ SBS 2003 and Linux do not support batch installation with ServerStart.
- ▶ ServerView is required configuration after installation even when the high reliability tools have been installed at once with ServerStart. Refer to "Chapter 5 High Reliability Tools" (→pg.93).

 **POINT**

- ▶ When using ServerStart to install the OS, RAID management tool and ServerView are installed together. These cannot be selected individually.
- ▶ To use all functions of ServerView, "Java2 Runtime Environment Standard Edition" and "Web server" are required. When using ServerStart to install the OS, "Java2 Runtime Environment Standard Edition" is installed automatically. For Web server, you can use either of the following by selecting a menu.
 - ServerView (for Apache)
Install ServerView Web-Server (Web server for ServerView, Apache for Win32 base) and install ServerView configuring to use this Web server.
 - ServerView (for IIS)
Install Microsoft Internet Information Server (IIS) supplied with Windows separately. ServerView is installed with the setting to operate using IIS installed on the system.
When IIS is not found in the system, ServerView Web-Server is installed even if "ServerView (for IIS)" is selected. ServerView (for Apache) is selected by default. To install ServerView (for IIS), select "ServerView (IIS Version)/RAID Management Tool". If "ServerView (IIS Version)/RAID Management Tool" is selected, ServerView (for Apache) is not installed.
It is not possible to release both of ServerView (for IIS) / ServerView (for Apache).
ServerView (for IIS) can not be installed in the Quick Installation mode.
- ▶ Intel® PROSet will be installed only when an optional LAN card is installed properly and the driver is applied correctly.
- ▶ If the OS is installed on other than drive C using ServerStart, Intel® PROSet will not be installed. In this case, install Intel® PROSet manually. For details, refer to "4.6.1 Intel® PROSet Installation" (→pg.90).

1.3 Component Names and Functions

This section explains the component names and functions of the server and baseboard.

1.3.1 Server (front view)

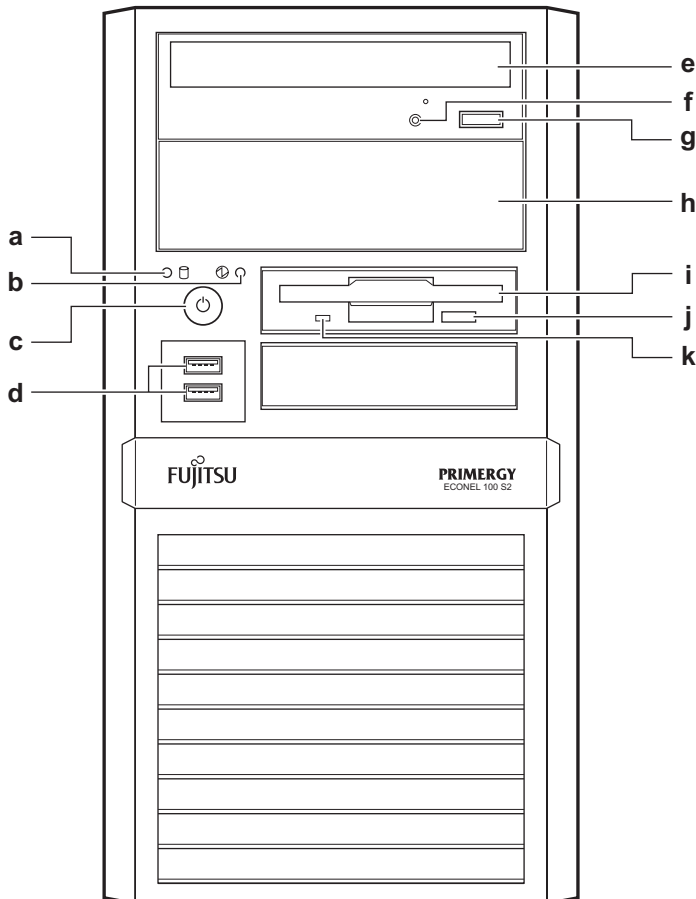

a Hard disk access LED (◻)

This LED is blinking when data is being written to or read from the hard disk.



- ▶ Do not turn off the server while the hard disk access LED is blinking. Data in the hard disk may be damaged.

b Power LED (⊕)

This LED is lit green when the server is turned on.

- c** Power switch
Press this switch to turn on the server.
- d** USB connector ()
Connect peripheral devices conforming to the USB standard (2.0 or 1.1).
- e** CD/DVD drive
This drive reads data or programs from a CD/DVD.
- f** CD/DVD access LED
This LED is blinking when data is being read from a CD/DVD.
- g** CD/DVD eject button
Press this button to eject a CD/DVD.
Do not press this when the CD/DVD access LED is lit.
- h** 5-inch storage bay
Install a 5-inch internal device.
- i** Floppy disk drive
This drive writes/reads data to/from a floppy disk.
- j** Floppy disk eject button
Press this button to eject a floppy disk.
Do not press this when the floppy disk access LED is lit.
- k** Floppy disk access LED
This LED is blinking when data is being written to or read from a floppy disk.

1.3.2 Server (rear view)

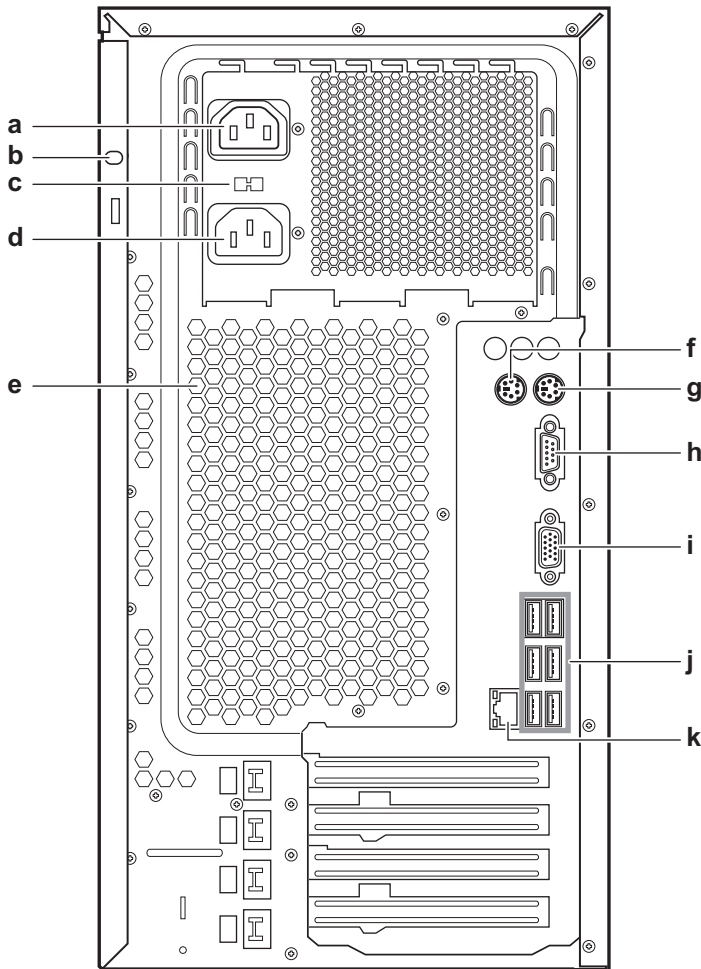

a Outlet

Connect the power cable of a peripheral device.

Use only a 300-watt device or smaller wattage.

To use this outlet when the UPS is connected to the server, make sure that the total wattage of the server and the peripheral devices does not exceed the UPS maximum wattage.

b Hole for an antitheft lock

The side cover can be locked by using this hole with an antitheft lock.

c 100V/200V switch

The visible value must correspond to the local mains voltage.

115 : 100 V to 127 V

230 : 200 V to 240 V

The initial values is set to 230. If it is necessary, sliding the switch changed the voltage rating.

d Inlet

Connect a power cable.

e Ventilation holes (cooling fan)

The holes let the heated air out of the server.

Put a release tie through the protrusion to fasten the power cables.

f Mouse connector ()

Connect a mouse cable.

g Keyboard connector ()

Connect a keyboard cable.

h Serial port ()

Connect a cable of a device conforming to the RS-232C standard such as a modem.

i Display connector ()

Connect a display cable.

j USB connector ()

Connect cables of peripheral devices conforming to the USB standard (2.0 or 1.1).

k LAN (10/100/1000BASE-T) port ()

Connect an Unshielded Twisted Pair (UTP) cable.

For 1000Mbps connection, a category 5 enhanced or a category 6 cable is required.

For 10Mbps/100Mbps connection, a category 5 or higher cable is required.



The meaning of the LED is shown in the table below.

table: Meaning of the LAN port LED

LED location	LED status	Connection status
Upper LED	Amber (lighting)	Connection established at 1000 Mbps
	Green (lighting)	Connection established at 100 Mbps
	Off	Connection established at 10 Mbps
Lower LED	Green (lighting)	Link is being established
	Green (blinking)	Data is being transferred

1.3.3 Server (internal)

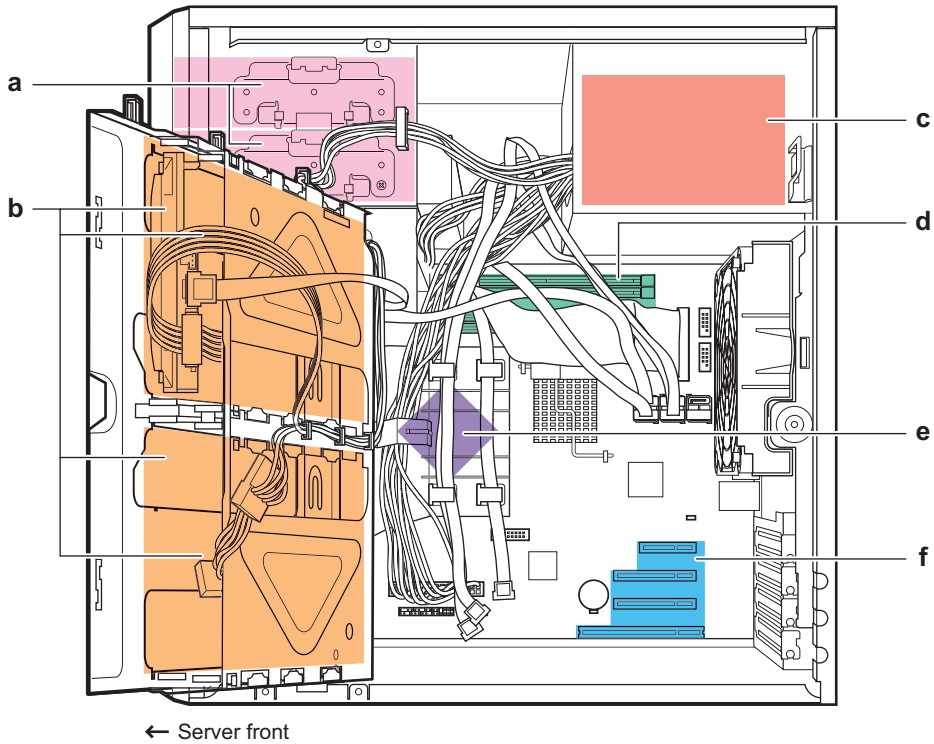

- a** 5-inch storage bay
Install a 5-inch internal device.
- b** 3.5-inch storage bay
Install internal hard disk units.
- c** Power supply unit
- d** Memory slot
Install memory modules.
- e** CPU
- f** PCI slot
Install expansion cards that enhance the server functions.

1.3.4 Baseboard

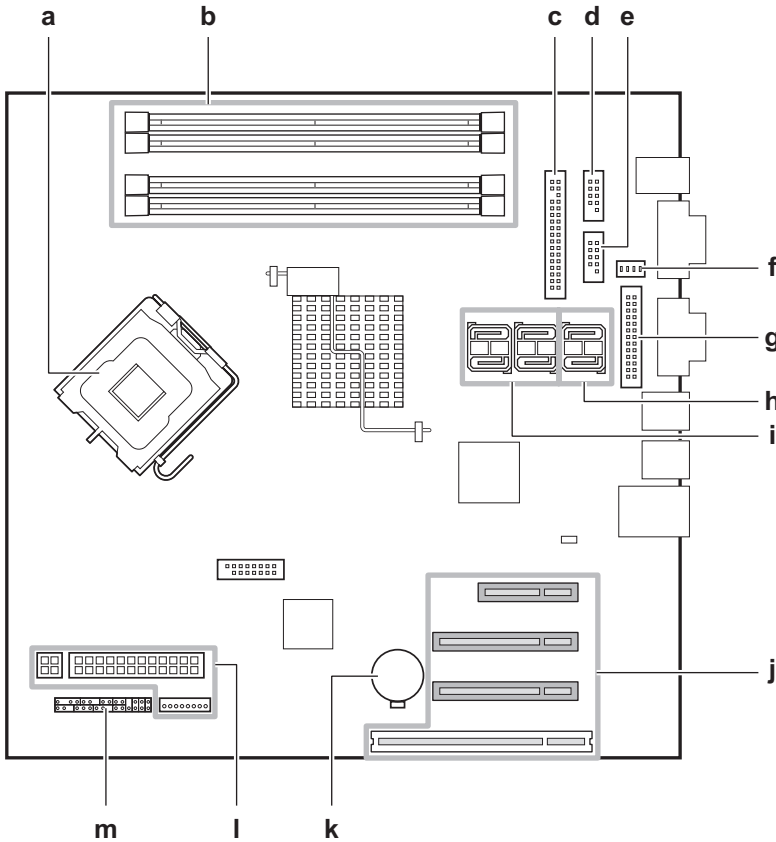

- a** CPU socket
Install a CPU.
- b** Memory slot
Install memory modules.
- c** Floppy disk drive connector
Connect a floppy disk drive cable.
- d** USB connector
Connect a USB cable when a Tape Drv DAT72 36GB internal or an Internal Data Cartridge Drive Unit is installed.
- e** USB Front connector
Connect a cable for USB port on the front side of the server.
- f** Fan connector
Connect a fan cable on the rear side of the server.
- g** Parallel port connector
Connect a cable of a Parallel Port.

h SATA connector 5, 6

Connect the SATA cable of the DVD-ROM unit, which is installed as a standard feature, to the SATA connector 5. SATA connector 6 is not used.

i SATA connector 1 to 4

Connect the SATA cables of the internal hard disk units. Match the bay numbers of the internal hard disk units with the connector numbers.

j PCI slot

Install an expansion card. PCI slot 1 to 4 are numbered from bottom to top in the figure shown above.

k Built-in server battery

This battery saves the server clock function settings and the BIOS settings.

l Power connector

Connect a power cable from a power supply unit.

m Front panel connector / jumper

Connect a front panel cable.

For details on jumper settings, refer to "7.1 Jumper Settings" (→pg.126).

1.4 Standard Operations

This section explains such standard operations as turning the server on/off and handling the disk drive.

1.4.1 Turning On the Server



CAUTION



Do not

- Do not move, strike, or shake the server when it is turned on. This can damage the hard disk in the server and cause data loss.



- Turn the server on when the temperature is in its operating environment range (10-35°C). For details about the operating environment, refer to "Start Guide" and "Safety Precautions".

When operating the device outside of this operating environment, the server may operate improperly, damage data etc.

Furthermore, Fujitsu cannot be held responsible for any related damage, malfunction, or loss of data, etc.



- The fans rotate at high speed immediately after the server is turned on, but this is not defective. When the temperature is in the server's operating environment range (10-35°C), they start to rotate at normal speed later.



- Be sure to wait for 10 seconds or more after shutdown before turning on the server.

- 1** Make sure that the floppy disk drive and CD/DVD drive are empty.
- 2** Turn on the display and peripheral devices.

3 Press the power switch on the front of the server.

The server's power LED is lit green.

When the power is turned on, the server performs Power On Self Tests (POST). If any abnormalities are detected by POST, error messages are displayed ("8.2.2 Error Messages" (→pg.150)).

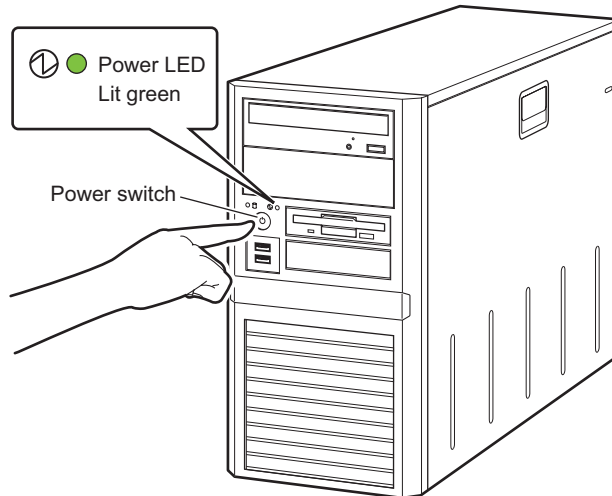

POINT

- ▶ The time to turn on the server can be set with the ASR setting (on the [Power On/Off] tab) using ServerView. For details, refer to "3.4 Serious Error Handling (ASR)" in "ServerView User's Guide".
- ▶ If you press the [F12] key right after the POST memory amount check, the [Boot] menu is displayed, where you can change the boot drives ("■ How to start up BIOS Setup Utility" (→pg.127)).

1.4.2 Turning Off the Server



- In the event of smoke or sparks, immediately disconnect the electric cord. Failure to do so may lead to a fire or electric shock.



- Follow the procedures below to turn off the server. Data can be lost if these procedures are not followed correctly.

1 Make sure that the floppy disk drive and CD/DVD drive are empty.

2 Shut down the OS.

In the following cases, the server is turned off after the OS is shut down (Step 4 is not necessary).

- Windows OS
- ServerView is installed

In other cases, make sure that the access LEDs of floppy disk and hard disk are off when the OS is shut down.

3 Press the power switch on the front of the server.

The server's power LED is off after the server is turned off.

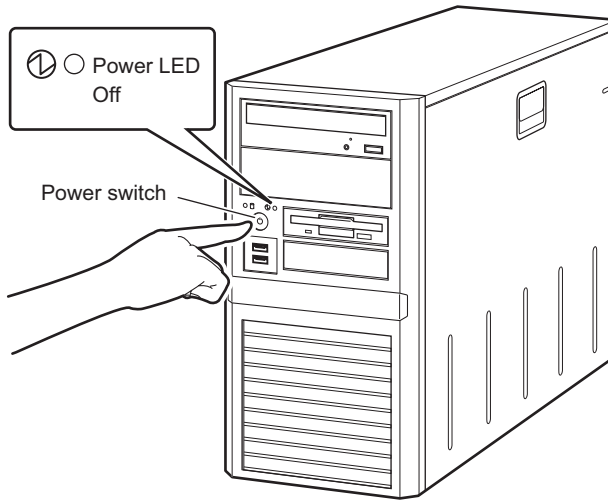

4 Turn off the display and peripheral devices.



- Be sure to wait for 10 seconds at least after shutdown before turning on the server.

POINT

- ▶ The time to turn off the server can be set with the ASR setting (on the [Power On/Off] tab) using ServerView. For details, refer to "3.4 Serious Error Handling (ASR)" in "ServerView User's Guide".

■ Cautions when turning the power off (Windows Server 2003)

For the power switch operation mode of this server, you can specify the following modes depending on the OS settings (normally, "Shutdown" is specified).

"Do Nothing", "Prompt Input", "Standby", "Hibernation", or "Shutdown"

On this server, functions corresponding to "Standby" and "Hibernation" are supported as BIOS and hardware functions. However, some drivers and software installed in the server do not support these functions. For this reason, functions corresponding to "Standby" and "Hibernation" are unavailable on this server. When the operating mode is set to "Standby" or "Hibernation", the system may operate improperly or hard disk data may be corrupted.

For details about operating mode settings, refer to the manual supplied with the OS.

1.4.3 Inserting and Ejecting a Floppy Disk

■ Cautions

When using floppy disks, note the following points to avoid failures:

- Do not expose the disk to any fluids.
- Do not open the shutter of the floppy disk and touch the disk surface.
- Do not bend the floppy disk or place heavy objects on it.
- Do not expose the floppy disk to strong magnetic fields.
- Do not drop the floppy disk on hard surfaces.
- Do not store the disk in extremely hot or cold conditions.
- Do not store the disk in humid or dusty conditions.
- Do not put layers of labels on the floppy disk. Doing so may cause the drive to be clogged with the disk.
- Keep the disk away from moisture condensation or water droplets.

■ Inserting the floppy disk

POINT

- ▶ Use a formatted floppy disk. Operations are not guaranteed when you use other floppy disks.

- 1** Insert the floppy with the label up into the floppy disk drive from the side with a shutter.

It makes a clicking sound and the floppy disk eject button pops out.

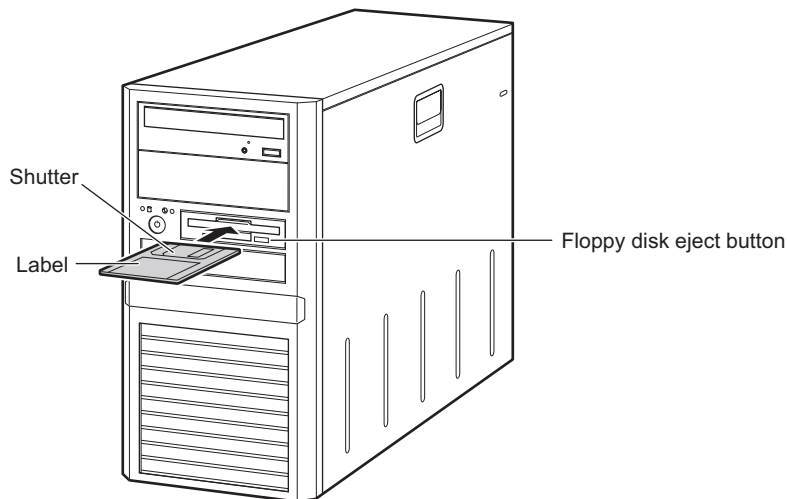

■ Ejecting the floppy disk

- 1** Make sure that the floppy disk access LED is off.

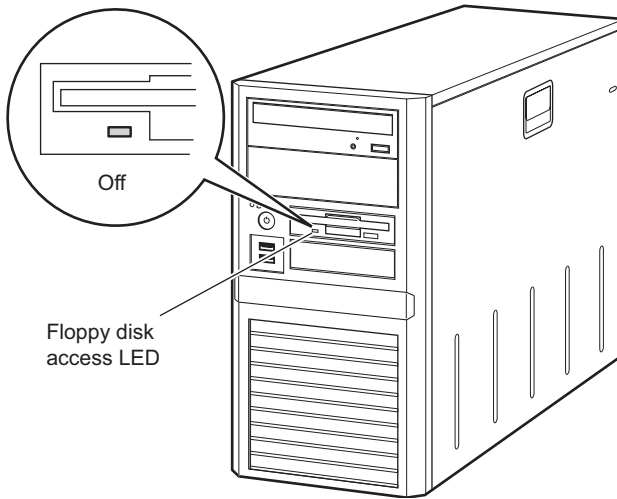

IMPORTANT

- ▶ Do not eject the floppy disk while the floppy disk access LED is lit. Doing so may damage data.

- 2** Press the floppy disk eject button.
The floppy disk comes out.

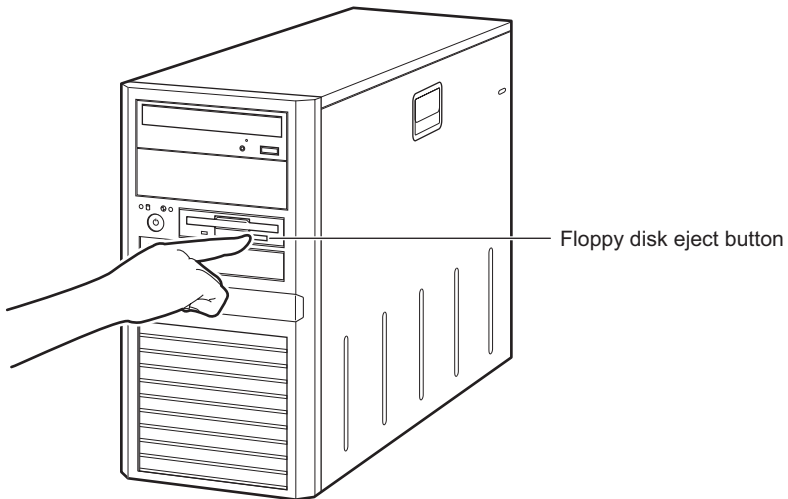

1.4.4 Inserting and Ejecting a CD/DVD

This section explains how to insert and eject a CD/DVD.

To prevent causes of mechanical failures, observe the precautions about handling CD/DVD stated below.



Do not look at the light source of the CD/DVD drive laser beam directly. Doing so may lead to visual damage.

■ Cautions for handling drives

- Avoid an area with high humidity and airborne dust level. Electric shocks and/or server failures may be caused by liquids such as water, or metallic items, such as paper clips, entering a drive.
- Do not use the drive in an area where is easily influenced by shocks and vibrations.
- Do not insert any objects other than the specific CD/DVDs.
- Do not pull on, press hard, or handle the CD/DVD tray roughly.
- Do not disassemble the CD/DVD drive.
- Before use, clean the CD/DVD tray using a soft, dry cloth.
- As a precaution, remove discs from the CD/DVD drive when the drive is not to be used for a long time. Keep the CD/DVD tray closed to prevent foreign matter, such as dust, from entering the CD/DVD drive.

■ Cautions for handling media

- Hold CD/DVDs by their edges to avoid contact with the disc surface.
- Do not contaminate the CD/DVD surface with fingerprints, oil, dust, etc. If dirty, clean with a soft, dry cloth, wiping from the center to the edge. Do not use benzene, thinners, water, record sprays, antistatic agents, or silicone-impregnated cloth.
- Be careful not to damage the CD/DVD surface.
- Keep the CD/DVDs away from heat sources.
- Do not bend or place heavy objects on CD/DVDs.
- Do not write with ballpoint pen or pencil on the label (printed) side.
- Do not attach stickers or similar to the label side. Doing so may cause rotational eccentricity and abnormal vibrations.
- When a CD/DVD is moved from a cold place to a warm place, moisture condensation on the CD/DVD surface can cause data read errors. In this case, wipe the CD/DVD with a soft dry cloth then let it air dry. Do not dry the CD/DVD using devices such as a hair dryer.
- To avoid dust, damage, and deformation, keep the CD/DVD in its case whenever it is not in use.
- Do not store CD/DVDs at high temperatures. Areas exposed to prolonged direct sunlight or near heating appliances are to be avoided.

■ Inserting CD/DVD

- 1** Make sure the server is turned on and press the CD/DVD eject button.
The CD/DVD tray comes out a little.

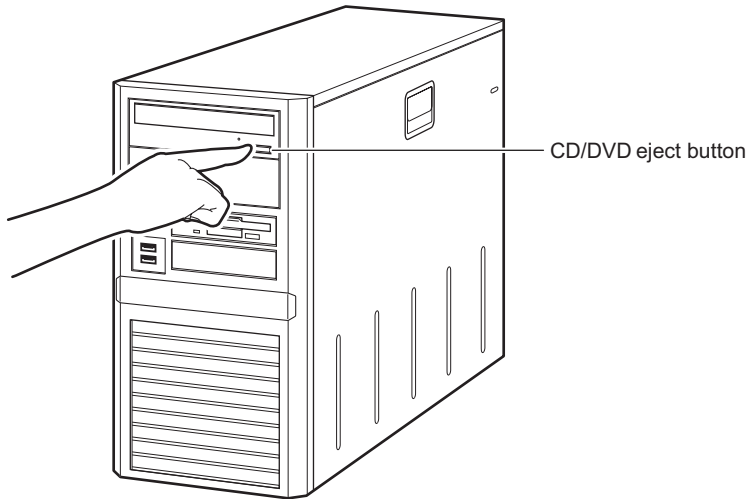

- 2** Place the CD/DVD with the label side up at the center of the tray.

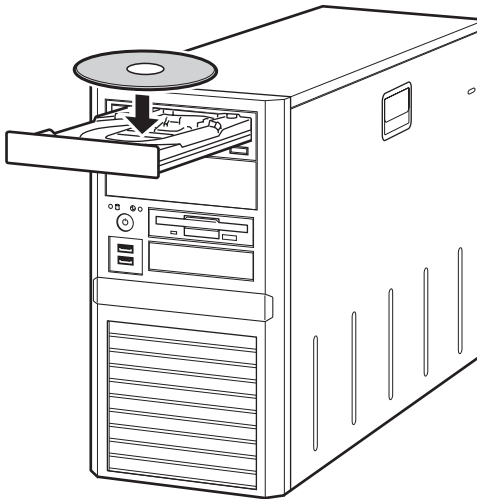

- 3** Press the CD/DVD eject button again.
The tray is inserted into the server and CD/DVD is set.

POINT

- ▶ When CD/DVD is set, the CD/DVD access LED is lit. To go to the next operation, check that the LED is off.

■ Ejecting CD/DVD

To eject the CD/DVD, confirm that the CD/DVD access LED is off and then press the CD/DVD eject button.

1.5 Workflow

To start the server operation, perform the following procedures.

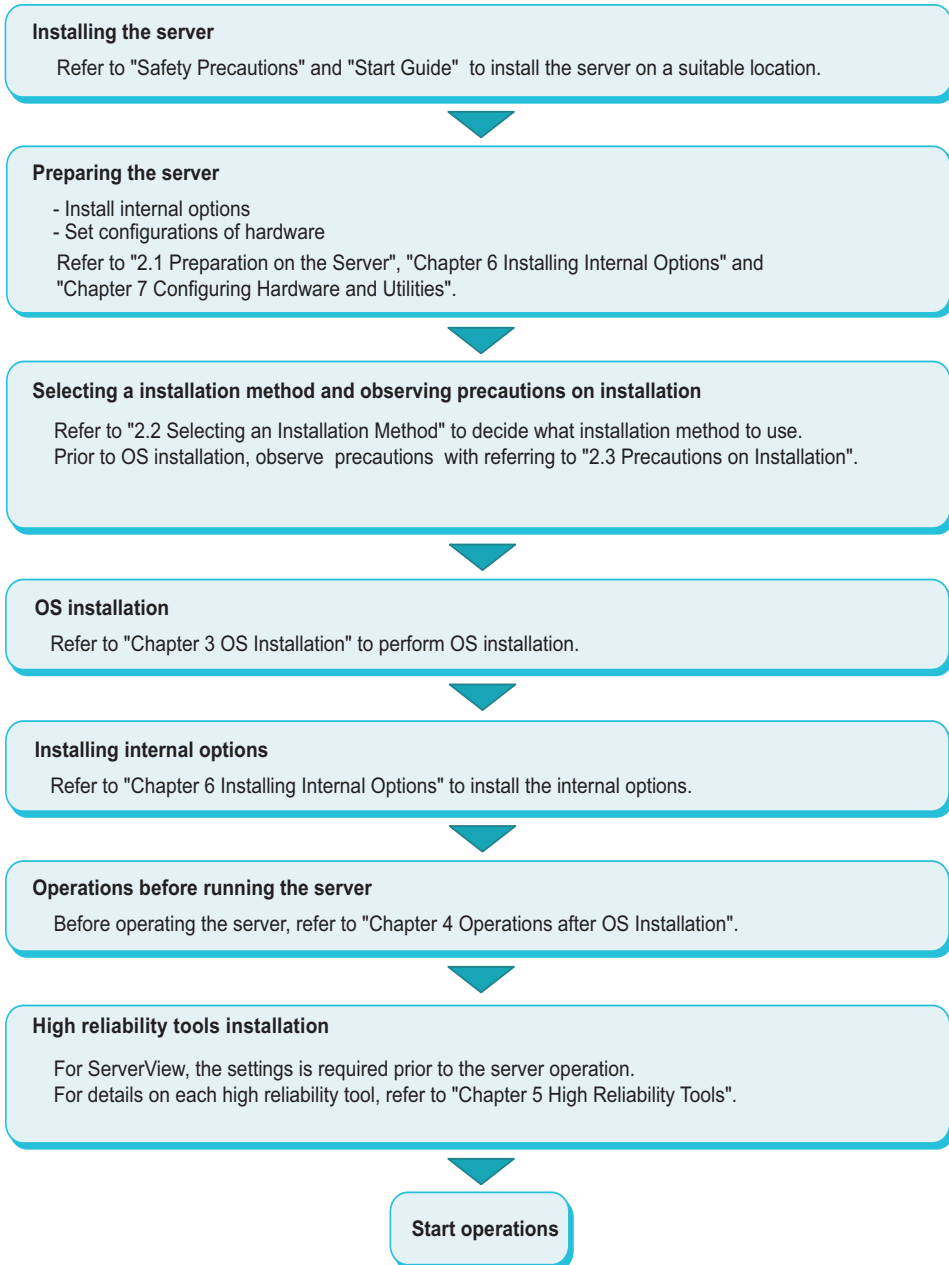

Chapter 2

Checking before OS Installation

2

This chapter explains the preparation and cautions for the server before OS installation. Observe this chapter before starting installation.

2.1	Preparation on the Server	38
2.2	Selecting an Installation Method	41
2.3	Precautions on Installation	42

2.1 Preparation on the Server

Before starting installation of the OS, install internal options in the server and perform hardware settings.

2.1.1 Installing Internal Options

The installation sequence depends on the internal options which must be installed before or after installation of the OS.

For installation procedures, refer to "Chapter 6 Installing Internal Options" (→pg.99).

● Options to be installed before the OS installation

- Internal hard disk units to install OS
- Memory modules
- Expansion cards

● Options to be installed after the OS installation

- A 5-inch internal device option
- Internal hard disk units where the OS is not installed



- ▶ If an internal device option that must be installed after the OS installation has been already installed, remove the device, and reinstall the device after completion of OS installation.

■ Installing optional USB connected devices

When installing USB connected devices, turn off power supply or unplug their connection cables from the server during the OS installation. Connect them again after the OS installation.

■ Cautions for installing an expansion card

When using an expansion card, read the notes on the expansion card.

■ Cautions for installing a memory module

The supported maximum capacity varies depending on OS to be installed. Furthermore, since the server uses part of memory as PCI resources, the maximum available capacity has limitation.

The following shows the maximum installable memory capacity and the maximum available capacity.

table: Installable memory capacity and available memory capacity

OS	Installed memory capacity	Available memory capacity
Windows Server 2003 SBS 2003	Up to 2GB	Same as the installed memory capacity
	2GB to 4GB	Available memory capacity varies depending on the setting in BIOS Setup Utility. Start up BIOS Setup Utility, select the [Advanced] menu – the [Advanced Processor Options] submenu, and then refer to the setting of [NX Memory Protection]. <ul style="list-style-type: none"> • [Disabled]: 2GB • [Enabled]: Same as the installed memory capacity ^{*1}
Windows Server 2003 x64	Installed memory capacity	Same as the installed memory capacity
Linux	Installed memory capacity	Same as the installed memory capacity

*1: Adding the /PAE option to the Boot.ini file also makes the installed memory capacity the available memory capacity. Refer to the Microsoft website for how to set /PAE option in the Boot.ini file.

■ LAN cable

Connect a LAN cable to the server that is disconnected from the Internet.



- ▶ Security problems may occur if you access the Internet during setup operation. Do not access the Internet until the setup completes.

When the OS installation and/or automatic installation of an application are performed without connecting the LAN cable to the LAN card, an error may be recorded in the event viewer after setup completes.

Connect a LAN cable to LAN card after Service Pack 2 is applied when:

- Performing a half-duplex connection with 10Mbps
- Installing Intel[®] PROSet

When performing OS installation with ServerStart to the server with a LAN card installed, Intel[®] PROSet is automatically installed.

2.1.2 Hardware Settings

Before starting installation of the OS, modify the settings of BIOS Setup Utility as necessary.

■ BIOS Setup Utility

BIOS Setup Utility must be set in the following cases. For details on how to set BIOS Setup Utility, refer to "7.2 BIOS Setup Utility" (→pg.127).

● Changing the boot drives

To change boot drives, start up BIOS Setup Utility, select the [Boot] menu, and then change the boot drives. For how to set up the boot drive, refer to "7.2.12 Boot Menu" (→pg.141).

2.2 Selecting an Installation Method

When installing the OS with ServerStart, there are multiple installation methods. Prior to OS installation, refer to the following to decide on the method.

POINT

- ▶ To install the OS manually, refer to the following "Manual OS Installation".
<http://www.fujitsu.com/global/services/computing/server/ia/driver/>

2.2.1 Supported OS

The following operating systems can be installed by using ServerStart V6.711.

- Microsoft® Windows Server® 2003, Standard Edition
- Microsoft® Windows Server® 2003, Enterprise Edition
- Microsoft® Windows Server® 2003, Standard x64 Edition
- Microsoft® Windows Server® 2003, Enterprise x64 Edition
- Microsoft® Windows Server® 2003 R2, Standard Edition
- Microsoft® Windows Server® 2003 R2, Enterprise Edition
- Microsoft® Windows Server® 2003 R2, Standard x64 Edition
- Microsoft® Windows Server® 2003 R2, Enterprise x64 Edition

POINT

- ▶ ServerStart does not support OS installation of SBS 2003 / Linux.
- ▶ Any of unsupported OS can not be installed.

2.2.2 Installation Modes of ServerStart

■ Quick Installation mode

This mode completes the OS installation by executing plain settings. Select this mode when you want to install the OS quickly and simply. To install while maintaining the established RAID environment, the Quick Installation mode must be selected to install the OS.

Select [Logical Disk 0] in the [Select the Boot Controller and Boot Disk] window and install the OS.

■ Expert mode

In this mode, start up Disk Manager and format the partition where your OS is installed prior to installation of the OS. Select the Expert mode only when installing the OS while maintaining the existing partitions. Also, when using ServerStart while maintaining the existing partitions, start up Disk Manager, format an installation partition and install the OS.

2.3 Precautions on Installation

Observe all the following notes before starting OS installation.

2.3.1 Installation Partition Size

The installation partition sizes are stated as below when using ServerStart to install your OS.

- Maximum size: 2TB
- Minimum size: 2200MB

● Notes

- When setting the OS and BOOT partitions on different partitions, specify the partition size directly. (The BOOT partition indicates the partition for startup. Minimum information required for startup such as "ntldr" is allocated on the partition. The OS partition indicates the partition for installing the OS.)
- In either of the following cases, specify a partition size 2TB or less.
 - When the same partition is specified as the OS and BOOT partitions
 - When different partitions are specified as the OS and BOOT partitions
- The OS cannot be installed on a partition larger than 2TB.

2.3.2 Notes on Configuring RAID

Observe the notes described as follows prior to configuring RAID.

■ Hard disk unit

- Only internal hard disk units can be used.

Although up to four internal hard disk units can be installed on this server, the number of available hard disk units to be installed varies depending on the RAID level to be configured. For details, refer to the manual in Array Controller Document & Tool CD.
- Be sure to use hard disk units of the same model with the same capacity.

■ Array configuration

The array configurations vary depending on the array controller to be used.

● When using an Onboard Software RAID

Configure a RAID with internal hard disk units which are connected to SATA connector 1 to 4 on the baseboard. The array controller to be employed is "Embedded MegaRAID SATA" and available RAID level is "RAID 0" or "RAID 1". For details, refer to "Embedded MegaRAID SATA User's Guide" in Array Controller Document & Tool CD.

● When using a SAS array controller card (MegaRAID SAS)

Configure a RAID with internal hard disk units which are connected to SAS RAID Ctrl w/ Cable (PG-248BC). The array controller to be employed is "MegaRAID SAS" and available RAID level is "RAID 0 / RAID 1 / RAID 1+0 / RAID 5 / RAID 6". For details, refer to "MegaRAID SAS User's Guide" in Array Controller Document & Tool CD.

POINT

- ▶ Only one array controller is available with connecting to the internal hard disk. Multiple array controllers can not be used. When a SAS array controller card is installed, the available array controller is "MegaRAID SAS" only.

■ Notes

- When RAID-configured hard disk unit is used
Hard disk units that have been used before may have unwanted partition information or array configuration information, which may cause unexpected problems. If you connect any hard disk units with usage history to this server, format them at low level on another system before connecting them to the server. For information on how to format the hard disk, refer to the manual supplied with the system to be used.
- Number of hard disk units
If the number of actually installed units is less than that of the setting for the number of units (plus one, when hot spare is specified), installation using ServerStart is aborted because of an error. When the number of actually installed hard disk units is larger than the configured, the disk units are set up according to the setting. Extra units will be configured as standby disk units.

2.3.3 Cautions for Using ServerStart

Observe the cautions described below when the OS installation is performed with ServerStart.

■ Operating ServerStart

Mainly, a mouse is used for ServerStart operations. In some cases, operation with the [Tab] key or cursor are not available. Be sure to use a mouse while operating ServerStart.

■ Configuration file (SerStartBatch.ini)

A configuration file stores the server setup and client information configured in ServerStart. To create a configuration file, use the ServerStart floppy disk supplied with this server. Store only one file on each floppy disk. Do not set the ServerStart floppy disk to the write-protected state. You can use any name for the configuration file. However, the file must be installed in the server as "SerStartBatch.ini". When installing the configuration file, make sure to save it as "SerStartBatch.ini" on the ServerStart floppy disk. Start up ServerStart, insert the ServerStart floppy disk containing "SerStartBatch.ini", and click [Start] to install the server.

■ Ejecting PRIMERGY Startup Disc

Do not eject PRIMERGY Startup Disc while ServerStart is running. If the PRIMERGY Startup Disc is ejected and inserted again, ServerStart starts up in multiple windows, and settings you have made may be lost.

■ Exiting ServerStart

After operation in the Expert mode, exiting ServerStart restarts the system. Remove discs from the floppy disk and CD/DVD drive and click [OK]. When the display on the screen disappears, turn off the system.

■ License for use of system for ServerStart

"License for Use of System for ServerStart" linked from the ServerStart startup window is a license for use of Windows PE contained in ServerStart of the PRIMERGY Startup Disc. Windows PE for starting up ServerStart can be only used for installing Windows Server 2003 R2 and Windows Server 2003, provided under a separate legal license.

■ Display of onboard LAN

Display of an onboard LAN on the OS is as below when OS installation performs with ServerStart.

table: Display of onboard LAN

LAN port	Property on My Network	LAN device name
Onboard LAN	Local Area Connection	Intel® 82566DM-2 Gigabit Network Connection

■ Adapter numbers

For ServerStart, onboard multiple LAN adapters (network adapter) may be configured on OS installation wizard.

To configure multiple LAN cards, select the adapter numbers in order of Adapter 1 and Adapter 2, and enter settings for each adapter. Note that the order of adapter numbers is not necessarily the same as the order of slots for the installed LAN adapters. This means that the setting for Adapter 1 is not always applied to the onboard LAN. After installing the OS, check the LAN adapters to make sure that they are configured as intended.

■ Setting up the printer

ServerStart does not support setup of printers. Perform installation after setup is completed.

2.3.4 Automatic Driver Installation with ServerStart

ServerStart supports automatic driver installation for the following expansion cards.

[table: Automatic driver installation](#)

Onboard controller/Card type	Product ID	Bus
Onboard FDD/IDE/SATA	-	-
Onboard LAN	-	PCI-E
Onboard VGA	-	PCI
Onboard Software RAID	-	-
SAS array controller card	PG-248BC	PCI-E
LAN card	PG-1853	PCI

Chapter 3

OS Installation

3

This chapter explains how to install the OS in the server using ServerStart.

3.1 Quick Installation Mode	48
3.2 Expert Mode	54

3.1 Quick Installation Mode

In this mode, the OS is installed after configuring minimum required settings. To install the OS quickly and easily, use the Quick Installation mode.

POINT

- ▶ To install the OS while maintaining the established RAID environment, Quick Installation mode must be employed to install the OS.

- 1 Turn on the server and insert PRIMERGY Startup Disc immediately. ServerStart starts up. The select-media window for the configuration file appears.

ServerStart - StartUp

FUJITSU COMPUTERS
SIEMENS

ServerStart

We make sure

PRIMERGY

Regional and language settings

Language: German English Keyboard: US-International

ServerStart mode

Standard mode
 GlobalFlash Light mode
 MDP mode

Connect status media and/or installation media via network

Network parameters

Get IP address automatically [DHCP]
 Take the following IP address:

IP address: . . .
Subnet mask: . . .
Default gateway: . . .

Status backup media

on local drive (floppy / USB stick)
Insert a media before you are pressing the "Continue" button
A: . . .

on local read only drive (CD / DVD)
Insert a media before you are pressing the "Continue" button
D: . . .

via network:

Folder: . . .
Account: . . .
Password: . . .

No status backup

Continue Exit

- 2** Insert the ServerStart floppy disk supplied with the server. Make sure that "on local drive (floppy/USB stick)" and "A:" are selected and click [Continue].

POINT

- ▶ Set the ServerStart floppy disk in the write-enabled state.

The [Initialization of ServerStart core running] window appears and the ServerStart initialization process starts. Depending on hardware configuration, this process may take a few minutes. After completion, the license agreement window appears.

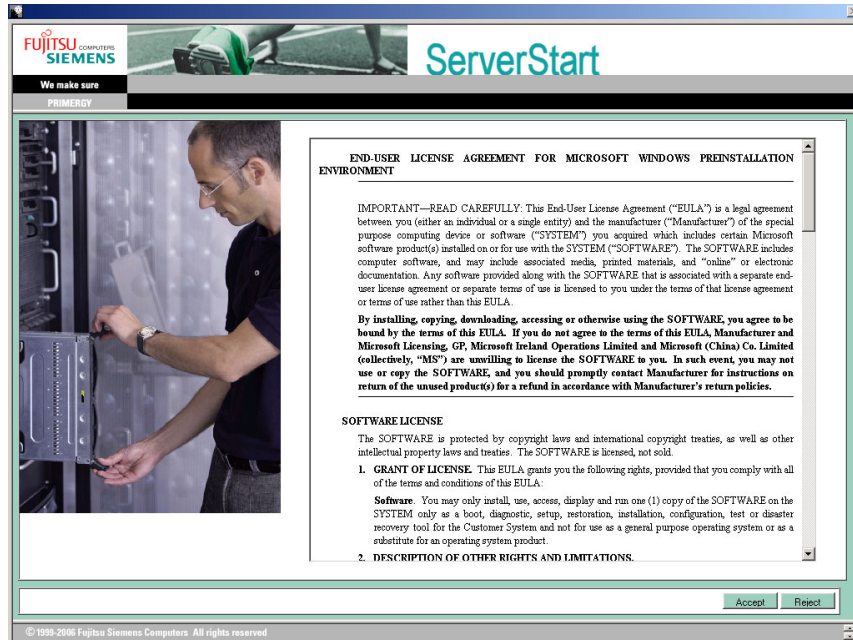

3 Click [Accept].

The [Welcome to ServerStart] window appears.

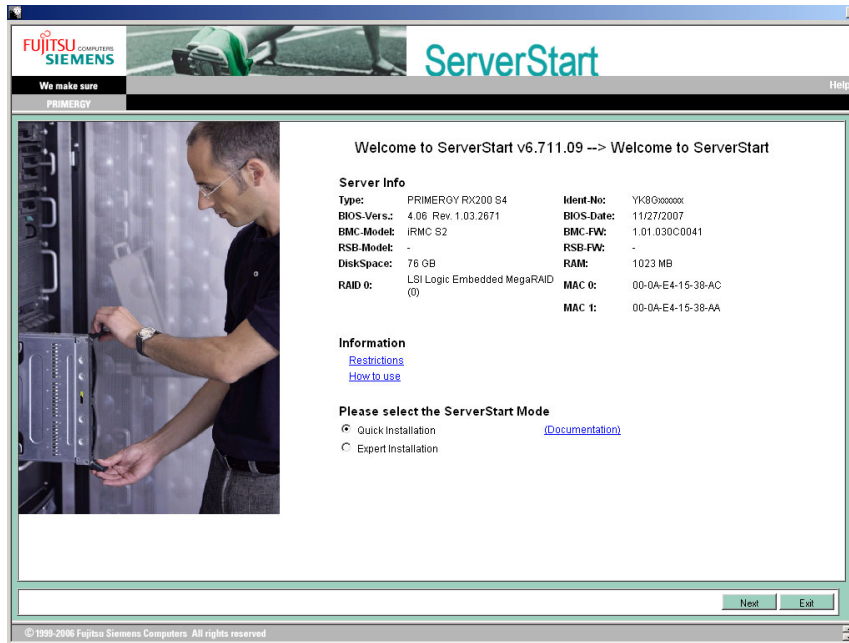

4 Select [Quick Installation] and click [Next].

The [Select the Boot Controller and Boot Disk] window appears.

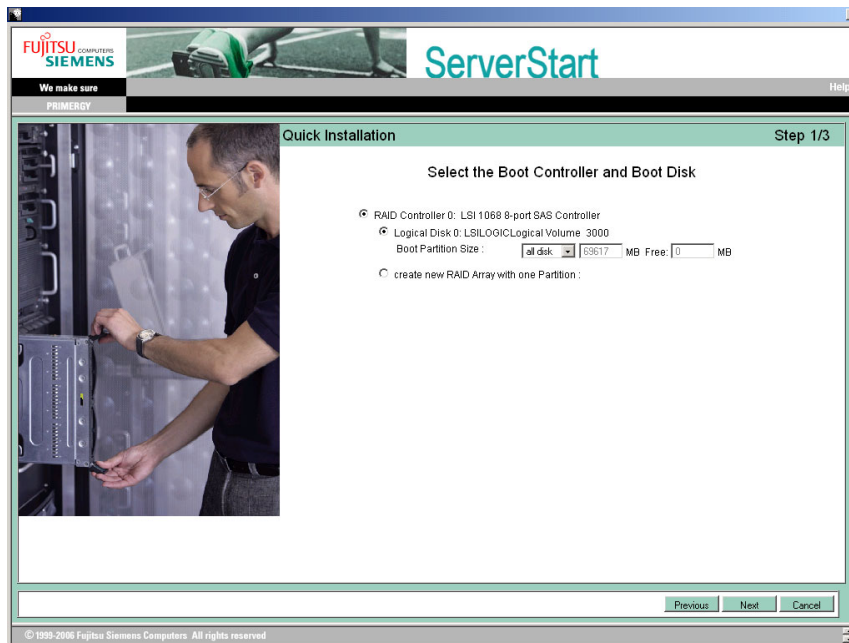

5 Set configuration of the RAID and disks and click [Next].

To install the OS while maintaining the established RAID environment

Select [Logical Disk 0] and specify partition size to be created.

One partition can be created. Select [Logical Disk 0] since the RAID is not required to be created.

To configure RAID

Select [create new RAID array with one partition] and specify the RAID level to be configured and the size of the partition.

All existing RAID will be deleted. Also, only one partition can be created.

POINT

- ▶ For a system with a SAS array controller card installed, the following RAID levels can be configured depending on the number of the installed disk units when [Auto] is selected.
 - When two hard disk units are installed: RAID 1
 - When three hard disk units are installed: RAID 5
 - When four hard disk units are installed: RAID 5 with hot spare function
- ▶ The configurations of the created partitions are as follows.
 - Volume label: system
 - File system: NTFS
 - Partition configuration: Boot/OS

The [Please select the OS to install] window appears.

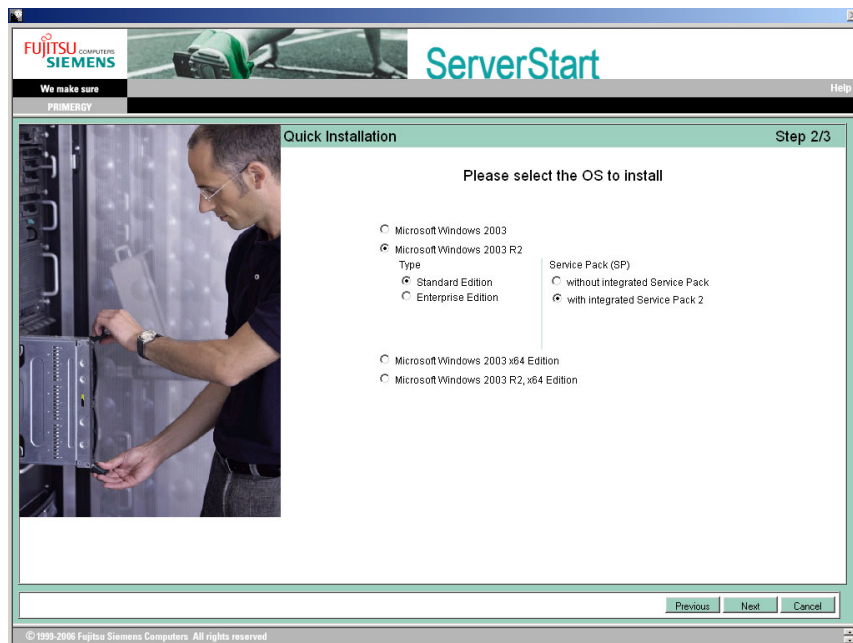

6 Select the OS to be installed and click [Next].

The [Configure your unattended Windows Installation] window appears.

7 Set the items and click [Next].

The [Summary] window appears.

8 Confirm the settings and click [Start Installation].**9** Click [Start now].

Installation starts.

1. If a message prompts you to insert Array Controller Document & Tool CD, insert the CD/DVD and click [OK].
2. If a message prompts you to insert Service Pack CD-ROM, Insert the CD-ROM and click [OK].

POINT

- ▶ When installing an OS with Service Pack 2 already applied, click [Cancel]. Skip to the next step without inserting Service Pack CD-ROM.

3. For Window Server 2003 x64, a message appears and prompts you to insert Startup Disc Win64 and restart the system. Insert Startup Disc Win64.

10 When a message prompts you to insert the OS CD/DVD, insert the CD/DVD and click [OK].

For Windows Server 2003 / Windows Server 2003 x64

1. Insert the OS CD/DVD (Installation disc).

After files are copied, a message prompts you to eject the CD/DVD and floppy disk.

For Windows Server 2003 R2 / Windows Server 2003 R2 x64

1. Insert the OS CD/DVD (Installation disc) Disc 1.
After files are copied, a message prompts you to insert the Disc 2.
2. Insert the OS CD/DVD (Installation disc) Disc 2.
After files are copied, a message prompts you to eject the CD/DVD and floppy disk.

11 Eject the CD/DVD and floppy disk and click [OK].

The system is restarted.

The system continues the installation operation after restart.

Setup of OS GUI and installation of LAN utility, Service Pack, and Active Directory are performed automatically.

12 When a confirmation message to restart appears, click [Restart].

The system restarts and installs high reliability tools.

POINT

- ▶ Thus the Command Prompt windows may appear and disappear during installation of ServerView, the installation process is properly proceeding.

13 Press the [Enter] key when a message notifies completion of installation.**14** Restart the system.

Click [Start] – [Shutdown]. Select [Restart] and click [OK].

The system restarts.

15 Configure the settings for the RAID management tool (ServerView RAID).

For the setting procedures, refer to the manuals in Array Controller Document & Tool CD.

- Settings of an array administrator account
The Windows user account is required when using ServerView RAID. Create a group named "raid-adm", and an account with any name for an array administrator within the group "raid-adm".
- Configuration of HDD Check Scheduler
Modify the settings of HDD Check Scheduler if necessary when using a SAS array controller card (MegaRAID SAS) and an Onboard Software RAID (Embedded MegaRAID SATA). It has been set at 12 o'clock every day as a default setting.

The server setup and OS installation have been completed.

Refer to "Chapter 4 Operations after OS Installation" (→pg.69) and perform necessary procedures before starting server operations.

3.2 Expert Mode

In this mode, start up Disk Manager, format the installation partition, and install the OS. Use this mode only when you want to perform installation while maintaining the existing partitions.

3.2.1 Starting Up the Expert Mode

Start up the Expert mode.

- 1 Turn on the server and insert PRIMERGY Startup Disc immediately. ServerStart starts up. The select-media window for the configuration file appears.

The screenshot shows the 'ServerStart - Startup' configuration window. The window title is 'ServerStart - Startup'. The interface includes the Fujitsu Siemens logo and a 'ServerStart' title. The main content area is divided into several sections:

- Regional and language settings:** Language is set to English (selected), and Keyboard is set to US-International.
- ServerStart mode:** Standard mode is selected.
- Network parameters:** The checkbox 'Connect status media and/or installation media via network' is unchecked. The 'Get IP address automatically [DHCP]' option is selected.
- Status backup media:** The 'on local drive (floppy / USB stick)' option is selected, with drive letter A: chosen. The 'on local read only drive (CD / DVD)' option is also visible, with drive letter D: chosen.

At the bottom of the window, there are 'Continue' and 'Exit' buttons.

- 2** Set the ServerStart floppy disk, provided with the server, and ensure that "Removable media" and "A:" are selected. Click [Create].

The [Initialization of ServerStart core running] window appears and the ServerStart initialization process starts. Depending on hardware configuration, this process may take a few minutes. After completion, the license agreement window appears.

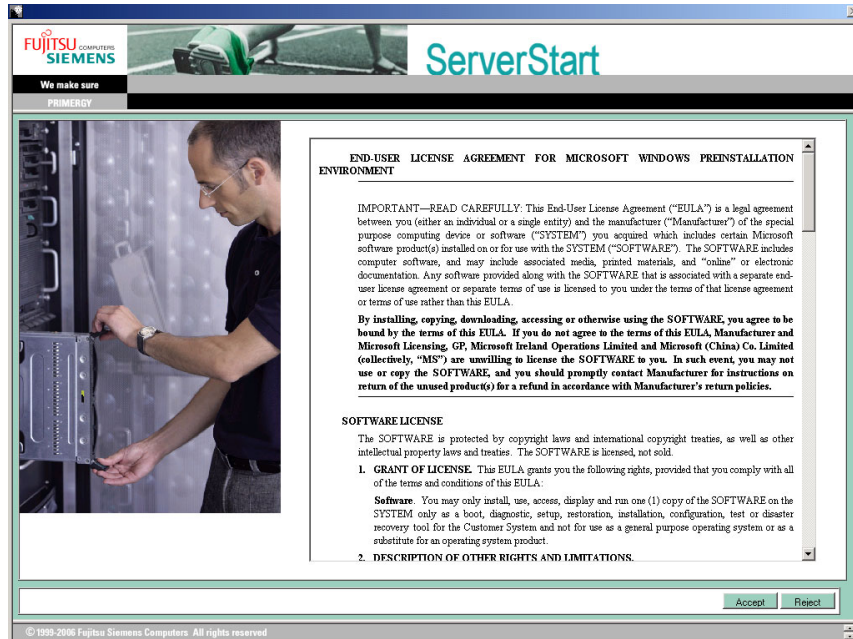

- 3** Click [Accept].

The [Welcome to ServerStart] window appears.

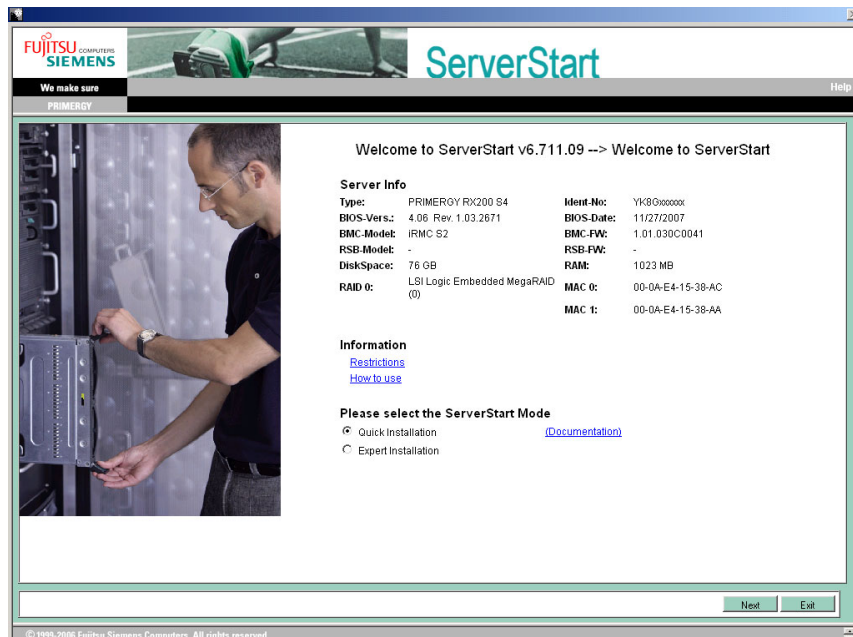

- 4 Select [Expert Installation] and click [Next].
The [Create a ServerStart Floppy Disk] window appears.

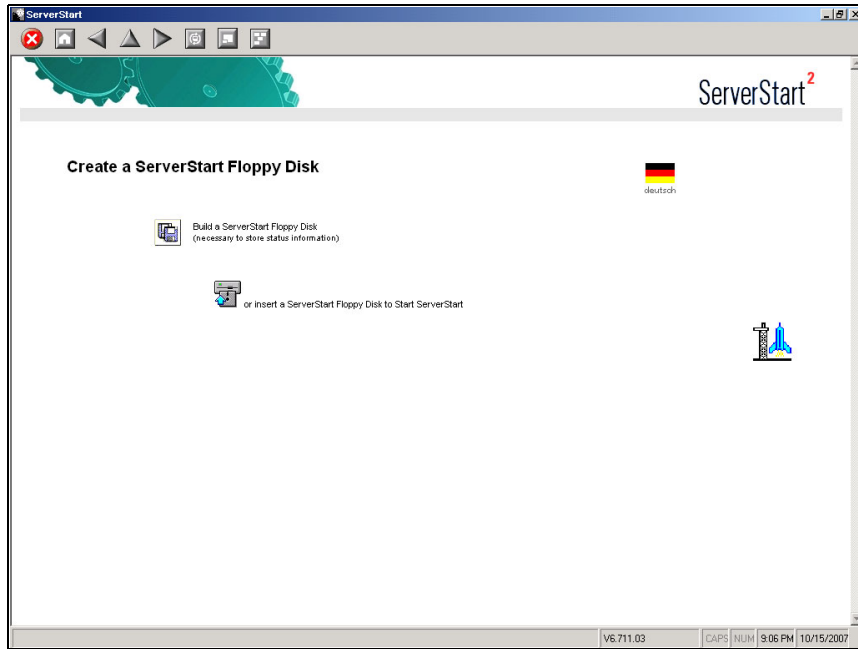

- 5 Click [Build a ServerStart Floppy Disk].
Creation of a ServerStart floppy disk starts. When the creation is completed, the "Floppy disk has been created." message appears.
- 6 Click [OK].
The [Please Select your Keyboard] window appears.
- 7 Select your keyboard language from the drop-down list and click [OK].
The subsequent start procedure may take several minutes.
The [Welcome to ServerStart] window appears.

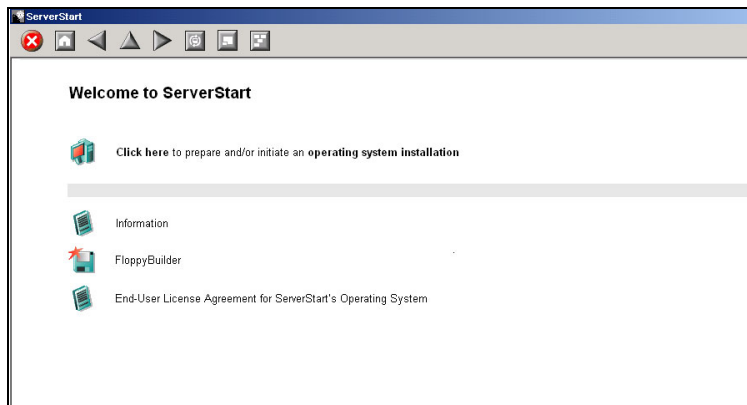

- 8** Click [Click here to prepare and/or initiate an operating system installation].
The [Select the operating system to be installed] window appears.
Click [Special Hints on Operating System Installation] and observe them carefully. Important information such as limitations on configuration of hard disk units is described.
- 9** Click [MS Windows Operating Systems].
The [Microsoft Windows Operating System Installation] window appears.
- 10** Click [Install MS Windows Server 2003 or MS Small Business Server (SBS) 2003].
The [Installation of MS Windows Server 2003] window appears.
- 11** Click [Install MS (OS) interactively (expertise required)].
The Expert mode starts.



Start up the configuration tools to set items. Exiting a tool returns to the display to the Expert mode window.



- ▶ Make sure to open the menu of each wizard and confirm the settings.

3.2.2 Disk Manager

Start up Disk Manager and format the installation partition.

- 1 Click [Use Disk Manager to partition and format your disk drives].
Disk Manager starts up.

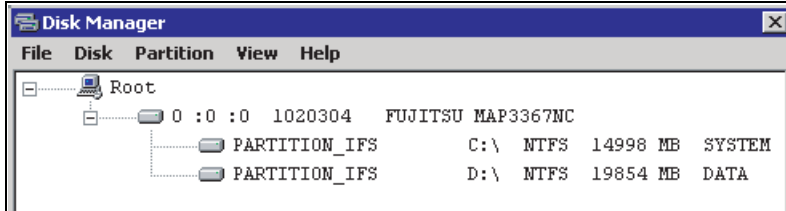

- 2 Format the OS installation partition. Select the OS installation partition and click the [Partition] menu – [Format].
The [Format Partition] window appears.

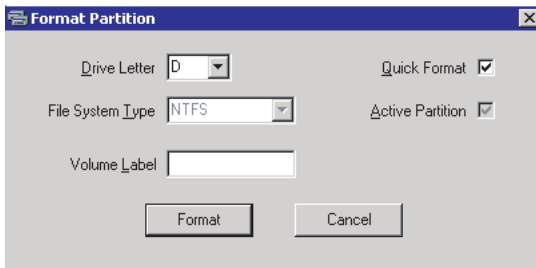

IMPORTANT

- ▶ Be sure to set the active partition on drive C.

- 3 Set items and click [Format].
The partition is formatted.
- 4 When the formatting is completed, click the [File] menu – [Exit].
Disk Manager closes and the display returns to the Expert mode window.

3.2.3 OS Installation Wizard

Set computer information, user information, and the network protocol.

ServerStart can configure multiple network patterns. When configuring a domain controller, refer to "Using ServerStart to Configure the Network".

POINT

- ▶ The setup windows vary depending on the OS to be installed. For example, operation on Windows Server 2003 R2 is given below. Windows Server 2003 R2 is corresponding to your OS to be installed.

1 Click [Installation Wizard for MS Windows Server 2003].

A message prompts you to specify the configuration file.

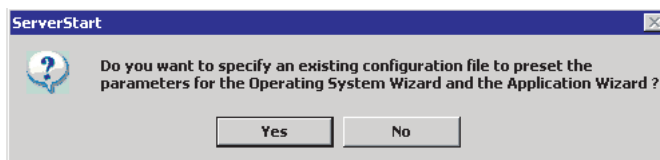

2 Click [No].

The [Windows Installation] window appears.

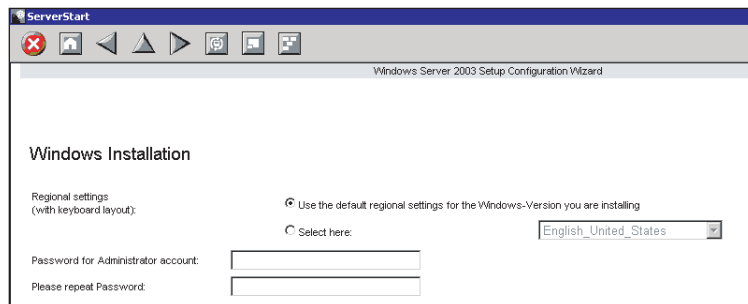

3 Enter the password in [Password for Administrator account] and [Please repeat Password] and click [Next].

POINT

- ▶ If the passwords of [Password for Administrator account] and [Please repeat Password] are not identical, an error message appears. Enter the password correctly.

The [Computer Identification] window appears.

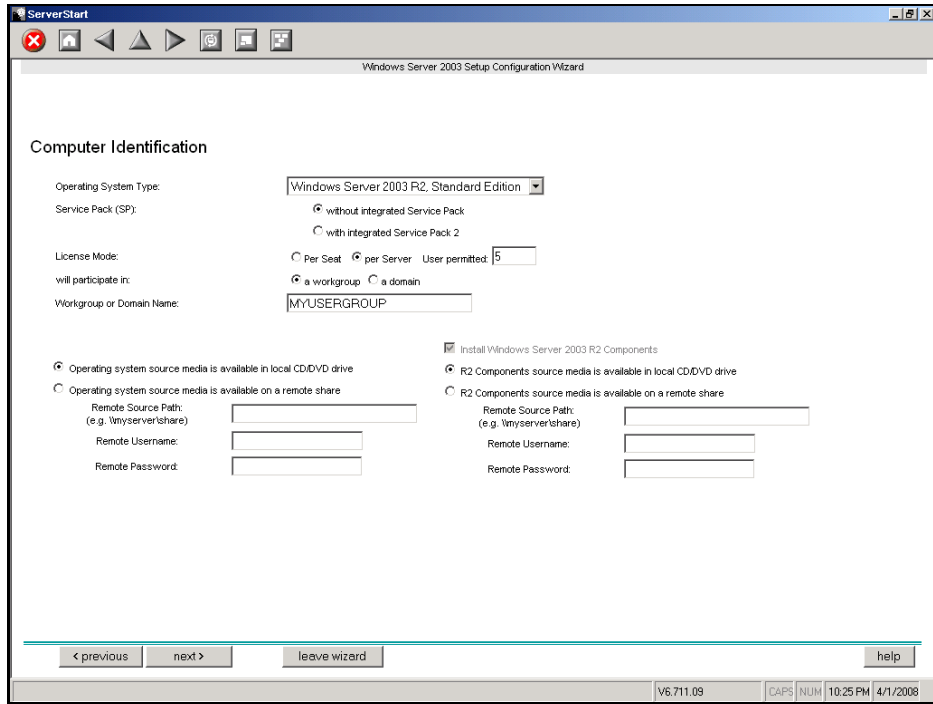

4 Set items and click [next].

The [Installation Directory and Time Zone] window appears.

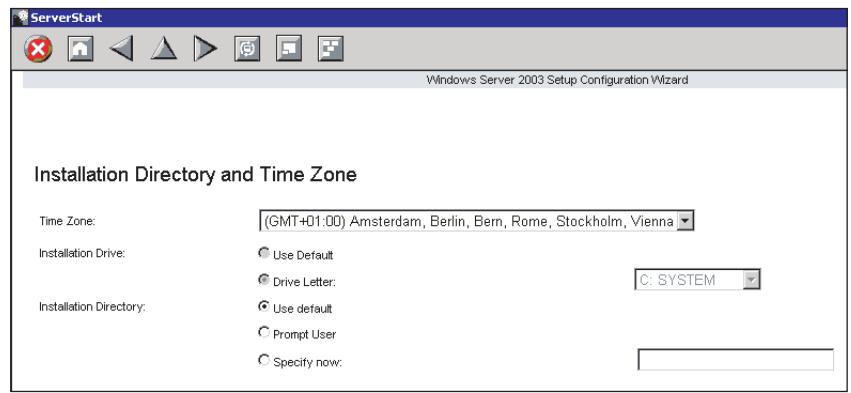

- 5** Set items and click [next].
The [User Name] window appears.

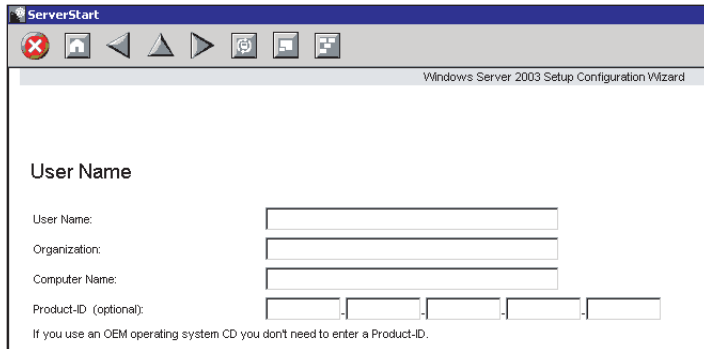

- 6** Set items and click [next].
The [Display Settings] window appears.

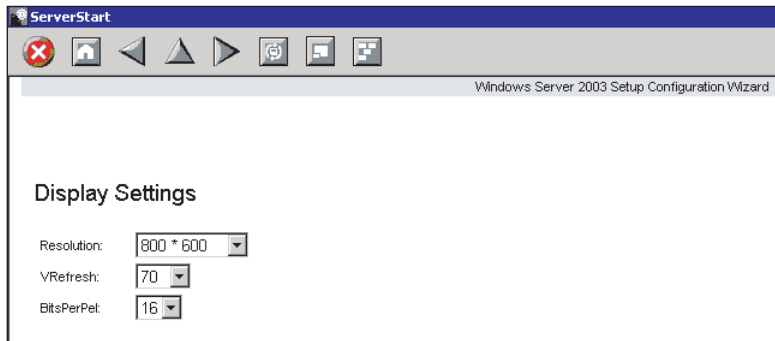

- 7** Set items and click [next].
The [Network Protocol] window appears.

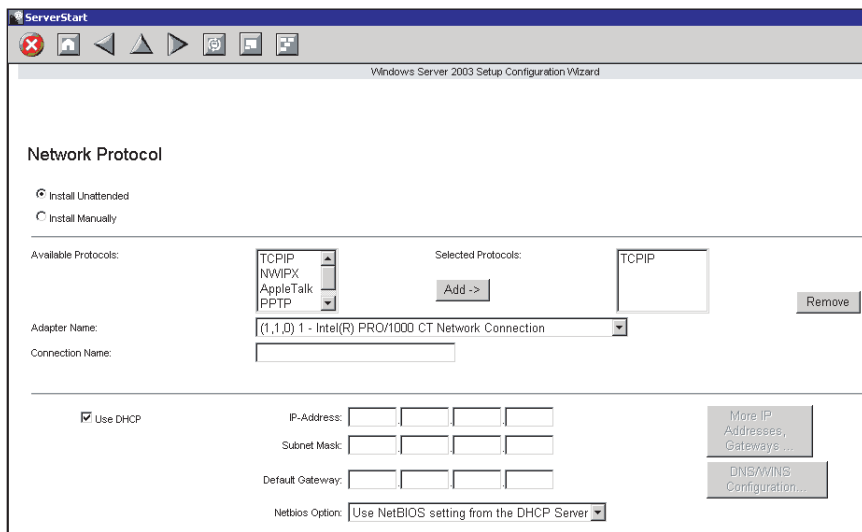

8 Set items and click [next].

The [Software Components] window appears.

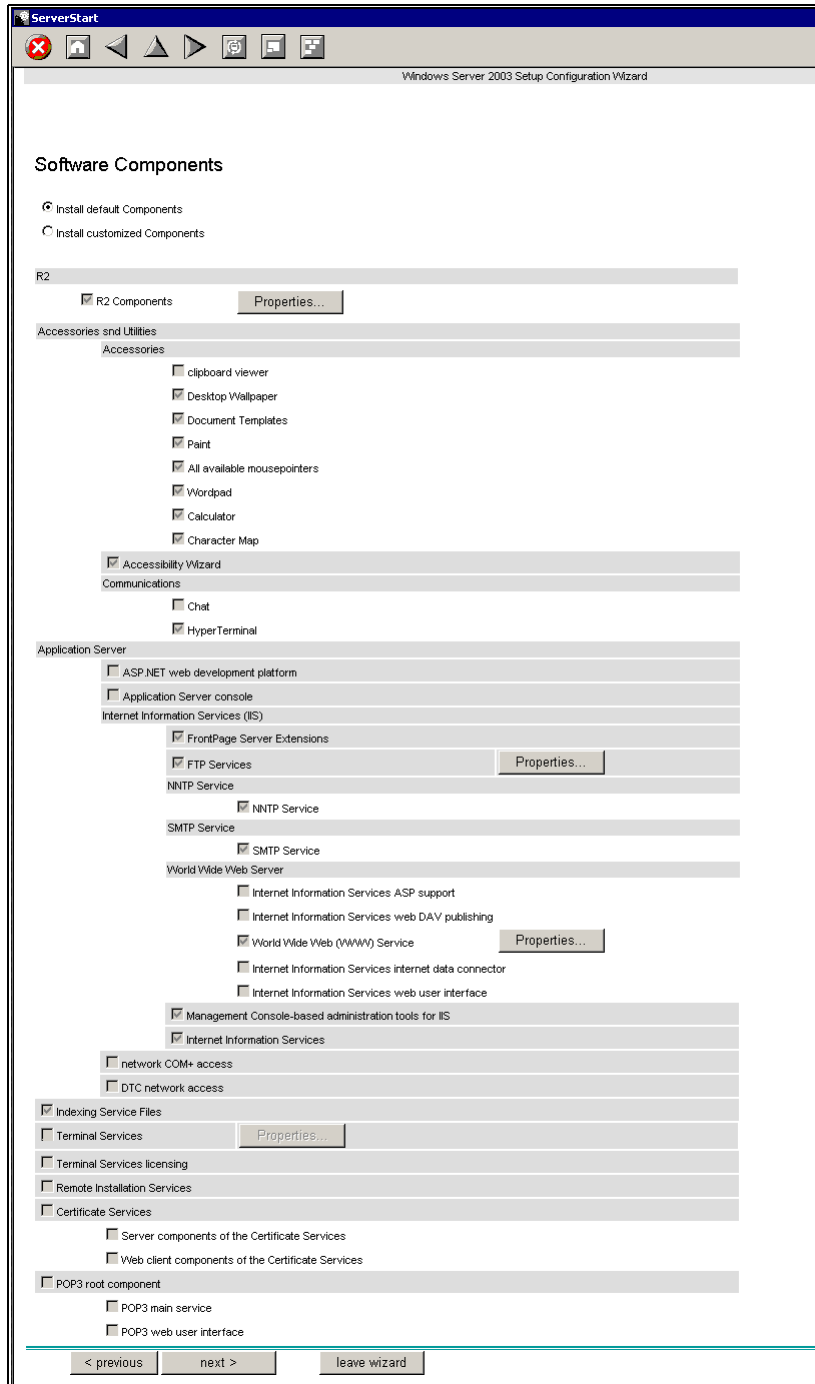

- ▶ If Windows Server 2003 R2 is selected at the Computer Identification, R2 components are always copied to the hard disk. To install the components, click [Properties] and check the box of the components to be installed.

- 9 Set items and click [next].
The [Services] window appears.

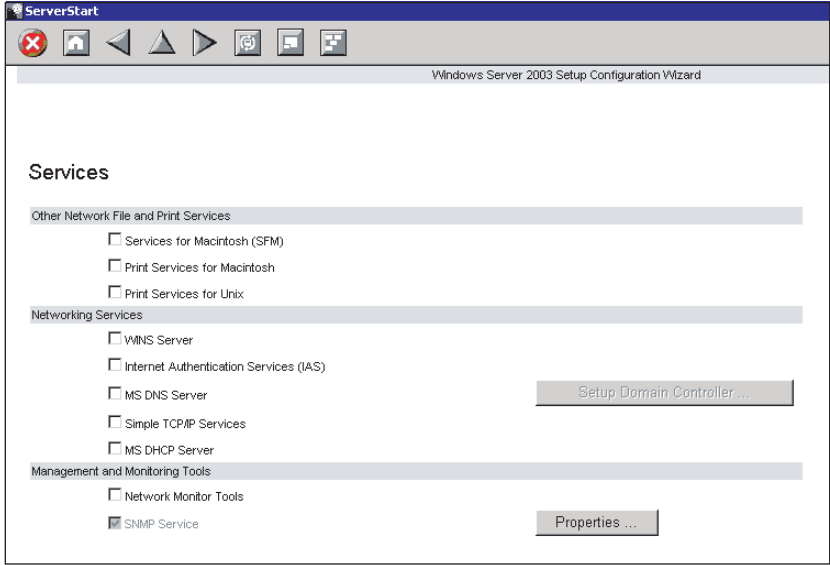

POINT

- ▶ Simple Network Management Protocol is always installed. Click [Properties] to change the settings.

- 10 Set items and click [leave wizard].
The display returns to the Expert mode window.

3.2.4 Application Wizard

Set configurations for installation of supplied applications such as high reliability tools. Open those windows and confirm the settings carefully.

1 Click [Application Wizard: Select additional software components].

The application wizard appears.

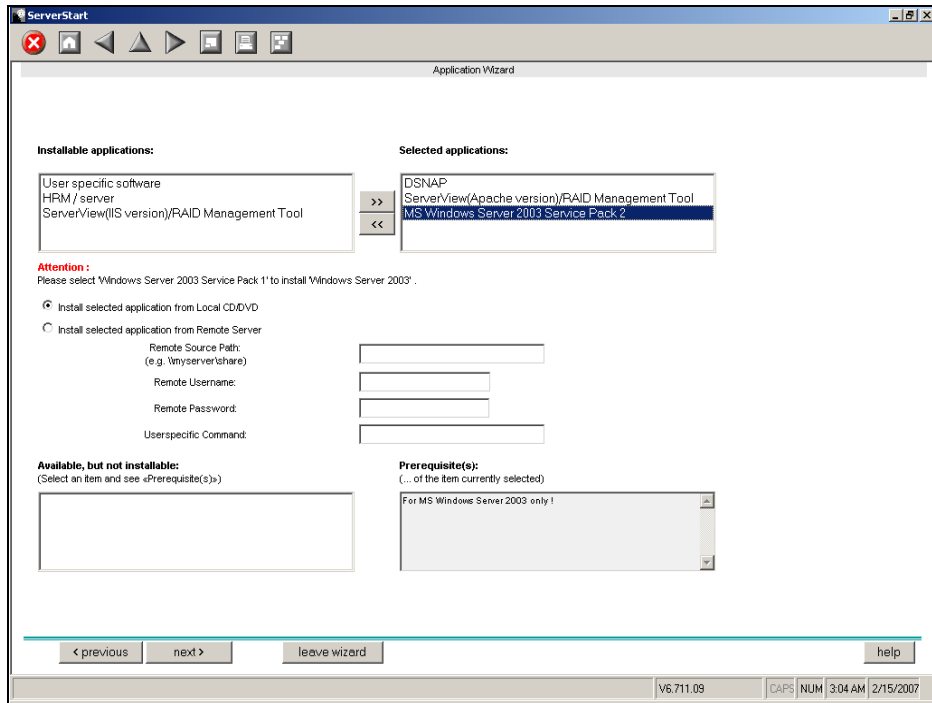

2 From the list in [Installable applications], select application software to be installed and click [>>].

Set all applications to be installed on the [Selected applications] list.

POINT

- ▶ Although the selection can be released in the Expert mode, it may take a long time to restore the system when errors occur without the management tools. Be sure to install these tools.
 - RAID management tool
 - ServerView (Apache)
 - ServerView (IIS)
 - HRM/server
 - DSNAP
- ▶ Only Service Pack 2 is available to perform automatic installation with ServerStart.

3 Click [leave wizard].

The application wizard closes.

3.2.5 Starting OS Installation

Install the operating system to the server.



Notes on the installation

- ▶ When the installation partition is not empty, a confirmation message appears. Unless otherwise considered as problem, click [OK] to continue the installation procedure.
- ▶ If an incorrect setting (such as the CD key) is found during installation, an error window will appear. Enter the correct values in the window to continue the installation procedure. However, corrections made here are not reflected on the configuration file.

1 Click [Click here, to Start the Installation of (OS)].

A confirmation window asking whether you want to save the current settings appears.

2 Click [Yes].

The following window appears.

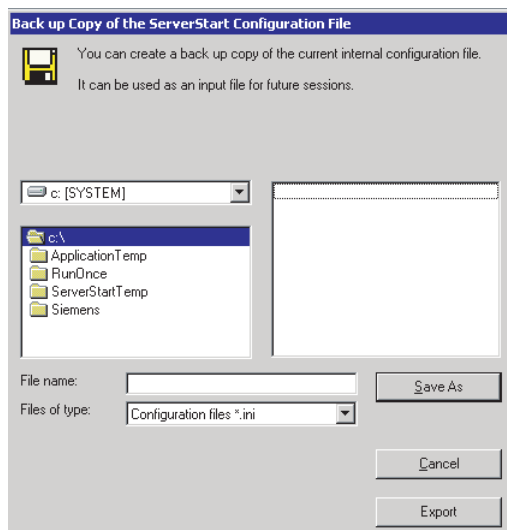

3 Enter the file name and click [Save As].

Installation starts automatically.

1. If a message prompts you to insert Array Controller Document & Tool CD, insert the CD-ROM and click [OK].
2. If a message prompts you to insert the Service Pack CD-ROM, insert the CD-ROM and click [OK].
3. For Window Server 2003 x64, a message appears and prompts you to insert Startup Disc Win64 and restart the system. Insert Startup Disc Win64.

- 4** When a message prompts you to insert the OS CD/DVD, insert the CD/DVD and click [OK].

For Windows Server 2003 / Windows Server 2003 x64

1. Insert the OS CD/DVD (Installation disc).

The license agreement window appears.

2. Click [I agree].

After files are copied, a message prompts you to eject the CD/DVD and floppy disk.

For Windows Server 2003 R2 / Windows Server 2003 R2 x64

1. Insert the OS CD/DVD (Installation disc) Disc 1.

The license agreement window appears.

2. Click [I agree].

After files are copied, a message prompts you to insert the Disc 2.

3. Insert the Disc 2 of OS CD/DVD (Installation disc).

After files are copied, a message prompts you to eject the CD/DVD and floppy disk.

- 5** Eject the CD/DVD and floppy disk and click [OK].

The system is restarted. The system continues the installation operation after restart.

Setup of OS GUI and installation of LAN utility, Service Pack, and Active Directory are performed automatically.

 **POINT**

- ▶ The message appears that SATA HDD is detected. Click [OK] and proceed to the operation.

- 6** When a confirmation message to restart appears, click [Restart].

The system restarts and installs high reliability tools.

 **POINT**

- ▶ Thus the Command Prompt windows may appear and disappear during installation of ServerView, the installation process is properly proceeding.

- 7** Press the [Enter] key when a message notifies completion of installation.

- 8** Restart the system.

Click [Start] – [Shutdown]. Select [Restart] and click [OK].

The system restarts.

- 9** Configure the settings for the RAID management tool (ServerView RAID).

For the setting procedures, refer to the manuals in Array Controller Document & Tool CD.

- Settings of an array administrator account

The Windows user account is required when using ServerView RAID. Create a group named "raid-adm", and an account with any name for an array administrator within the group "raid-adm".

- Configuration of HDD Check Scheduler

Modify the settings of HDD Check Scheduler if necessary when using a SAS array controller card (MegaRAID SAS) and an Onboard Software RAID (Embedded MegaRAID SATA). It has been set at 12 o'clock every day as a default setting.

The server setup and OS installation have been completed. Refer to "Chapter 4 Operations after OS Installation" (→pg.69) and perform necessary procedures before starting server operations.

Chapter 4

Operations after OS Installation

4

This chapter explains the operations to be performed after OS installation. Be sure to perform these operations before operating the server.

4.1	Memory Dump/Paging File Setting	70
4.2	Creating a Disk for System Recovery	75
4.3	Storing the System Configuration Information	77
4.4	Creating Maintenance Tools and Driver Disks	80
4.5	Notes before Operating the Server	87
4.6	LAN Driver Advanced Setup [Intel® PROSet]	90

4.1 Memory Dump/Paging File Setting

Before starting operating this server, configure the setting for obtaining memory dump.

● Memory dump

Debugging information, when memory dump has been set, will be automatically saved in case that a STOP error (fatal system error) occurs in the system. Error causes may be apparent by analyzing the saved memory dump.

When a large-capacity memory is installed, care shall be exercised to configure the settings of the memory dump file. The settings for obtaining memory dump should be configured after installing the files to be used for operations (OS, applications, etc.).

4.1.1 How to Obtain Memory Dump

Check the following settings before starting configuration to obtain memory dump.

■ Checking hard disk free space

To obtain memory dump, sufficient hard disk capacity is required for creating paging files and memory dump files. The obtainable dump types and required hard disk capacity are as follows.

● Complete memory (full) dump (recommended)

When the system unexpectedly stops, contents of the whole system memory are recorded. The file is stored in the directory displayed in the [Dump file] box.

- Paging file: Installed physical memory + 11MB (Recommended: Installed physical memory × 1.5)
- Memory dump file: Equivalent to installed physical memory



- ▶ Complete memory dump can not be used on the computer in which the 2GB or larger memory is installed.

● Kernel memory dump

Information of only kernel memory space is recorded. The file is stored in the directory displayed in the [Dump file] box. Capacity required for kernel memory dump is as follows:

- Paging file: Depending on installed physical memory amount
 - For memory of 256 to 1,373MB - Installed physical memory × 1.5
 - For memory of 1,374MB or more - 32-bit system: 2GB + 16MB, 64-bit system: Installed physical memory + 128MB
- Memory dump file: Depending on the kernel-mode address space being used during STOP

● Small memory dump

Minimum information to identify a problem is recorded. When this option is selected, a new file is created each time the system unexpectedly stops.

Those file histories are stored in the directory displayed in [Small dump directory].

- Paging file: Minimum 2MB
- Memory dump file: 64KB or 128KB

■ Memory dump file setting

Set up the memory dump file according to the following procedure.

- 1** Log on to the server with the administrator account.
- 2** Check free space of the drive where the memory dump file is to be stored.
Check the required free space according to "■ Checking hard disk free space" (→pg.70).
If the drive has insufficient free space, refer to "■ Cannot collect the memory dump" (→pg.157).
- 3** Click [Start] – [Control Panel] – [System].
The [System Properties] window appears.
- 4** Click the [Advanced] tab and click [Settings] in [Startup and Recovery].
The [Startup and Recovery] window appears.

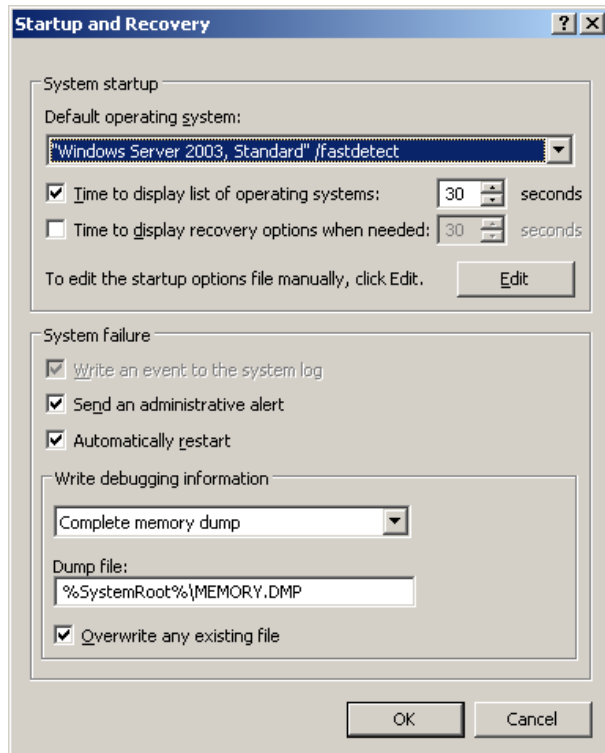

5 Set as follows:

1. In the [Write debugging information] section, select the memory dump file type.
 - Complete memory dump (Recommended)
The whole system memory information is recorded to the memory dump file.
 - Kernel memory dump
Only kernel memory is recorded to the memory dump file.
 - Small memory dump (64KB)
Minimum information is recorded to the memory dump file.
Each time a fatal error occurs, a new file is created in the directory specified in [Small dump directory].
2. In [Dump file] or [Small dump directory], specify the directory to save the memory dump file, with its full path.
For kernel memory dump or complete memory dump, when you check the box of the [Overwrite any existing file], debugging information is overwritten to the specified file every time.

6 Click [OK] to close the [Startup and Recovery] window.

7 Click [OK] to close the [System Properties] window.

8 Restart the system.

The setting is enabled after the system restarts.

■ **Paging file setting**

Set up the paging file according to the following procedure.

1 Log on to the server with the administrator account.

2 Check free space of the drive where the system has been installed.

Check the required free space according to "■ Checking hard disk free space" (→pg.70).

If the drive has insufficient free space, refer to "■ Cannot collect the memory dump" (→pg.157).

3 Click [Start] – [Control Panel] – [System].

The [System Properties] window appears.

4 Click the [Advanced] tab and click [Settings] in [Performance].

The [Performance Options] window appears.

5 Click the [Advanced] tab.

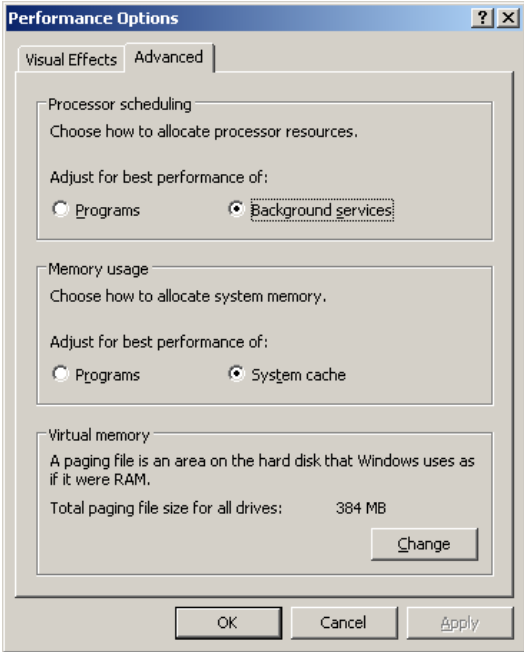

6 Click [Change] of the [Virtual memory].
The [Virtual Memory] window appears.

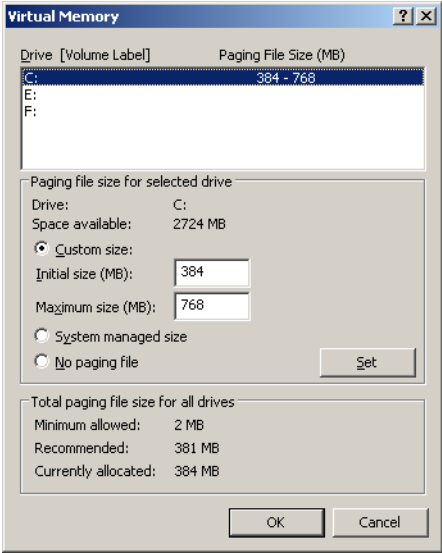

7 Select the drive where the paging file is to be created.
In [Drive], select the drive where the system is installed.
The selected drive is displayed in [Drive] in [Paging file size for selected drive].

8 Select [Custom size] and enter a value in [Initial size].

The value depends on the type of the set dump file.

Set a value larger than the value shown in [Recommended] in [Total paging file size for all drives].



- ▶ When a smaller value is specified for the paging file size, performance may be affected. For maximum system efficiency, be sure to set [Initial size] with a value larger than the [Recommended] size described in [Total paging file size for all drives]. The recommended size is total memory installed in the system \times 1.5. However, if a program occupies a large part of memory is regularly used, set a larger size as required.

9 Enter a value in [Maximum size].

Set a value larger than the [Initial size].

10 Save the settings.

Click [Set] in the [Paging file size for selected drive] section.

The settings are saved, and the value specified is displayed in [Paging File Size] of [Drive].

11 Click [OK] to close the [Virtual Memory] window.

12 Click [OK] to close the [Performance Options] window.

13 Click [OK] to close the [System Properties] window.

14 Restart the system.

The setting is enabled after the system is restarted.

■ **Rebooting after OS dump setting**

Rebooting may not be executed when the server fails even if rebooting has been set after obtaining dumping.

Immediate provision may be required when the server fails. However, configure the settings of rebooting with the Software Watchdog, when continuous operation is required. For details and configuration procedures for the Software Watchdog, refer to "3.4 Serious Error Handling (ASR)" in "ServerView User's Guide".

4.2 Creating a Disk for System Recovery

If the installation of the OS was performed manually, create a system recovery disk.

POINT

- ▶ If the system file, system configuration, or environment setting change at startup, etc., is damaged, such data can be reconstructed using the recovery information stored in the created system recovery disk.
- ▶ To create a recovery disk, prepare an unused formatted floppy disk.

4.2.1 Creating the Automated System Recovery (ASR) Set

After setting up Windows Server 2003, create a system recovery set. An unused formatted floppy disk and a medium are required to store back up files.

- 1** Click [Start] – [All Programs] – [Accessories] – [System Tool] – [Backup].
The [Backup or Recovery Wizard] window appears.
- 2** Click [Next].
The [Backup or Recovery] window appears.
- 3** Select [Create a backup of files and settings], and then click [Next].
The [Items to Create Backups] window appears.
- 4** Select [All the information in this computer], and then click [Next].
The [Backup Type, Destination and Name of the Backup File] window appears.
- 5** Enter a name and a destination of the backup file, and then click [Next].
The [Backup or Recovery Wizard Complete] window appears.
- 6** Click [Finish].
Backup process starts.
- 7** If a message prompts you to insert a floppy disk, insert the floppy disk and click [OK].
Automated system recovery disk is created.
- 8** When the process is completed, a message appears. Eject the floppy disk according to the message and put a label on it.
Label Example: "Windows Automated System Recovery Disk: Backup.bkf, Created at 12:00 02/01/2008"

- 9** Click [OK] to exit [Backup Utility].
- 10** Click [Close] to close the [Backup Progress] window.
An automated system recovery set has been created.
Store the automated system recovery set just created for sure.

4.3 Storing the System Configuration Information

Before starting operations and when changing the system configuration information, store the configuration information. By storing this information, the system can be recovered with the stored information in case of a system failure (such as when the baseboard fails). Use Server Management Tools for storing and recovering the system configuration information.



- ▶ Since the system configuration information is significant in maintaining the server, be sure to store the configuration information after the following operations:
 - When the information is changed with BIOS Setup Utility
 - When the hardware configuration of this server is changed (e.g. memory, hard disk unit, baseboard or expansion card is added/removed or changed)
- ▶ As the stored system configuration information will be used for maintenance operation.

■ Cautions

- When using ServerStart floppy disk, check that the USB floppy disk drive is connected before turning on the server.
- "Server Management Tools" disk is exclusively for this server. Do not use it on other systems. Otherwise, the systems may be damaged.
- Only the information that is configured with BIOS Setup Utility can be stored/recovered.
- Make sure to perform this operation only when the server is started with the "Server Management Tools" disk. Do not run Server Management Tools on the server started from the hard disk or by the other floppy disk. Otherwise, the system may be damaged.
- Do not eject a floppy disk while the floppy disk access LED is lit. Such an action may lead not only to corruption of the floppy disk data but also an unstable state of the system.
- If an error message appears while running Server Management Tools, respond to the message according to "■ Server Management Tools error messages" (→pg.154).

■ Creating "Server Management Tools" disk

"Server Management Tools" disk is required to be created when stated as "blank" on the label of the "Server Management Tools" disk supplied with the server. Create "Server Management Tools" disk by referring to "4.4 Creating Maintenance Tools and Driver Disks" (→pg.80).

4.3.1 Storing the BIOS Information

Store the BIOS information according to the following procedure.



- ▶ "Server Management Tools" disk is required to be created when stated as "blank" on the label of the "Server Management Tools" disk, supplied with the server. Create "Server Management Tools" disk by referring to "4.4 Creating Maintenance Tools and Driver Disks" (→pg.80).

1 Insert the "Server Management Tools" disk into the floppy disk drive and turn on the server.

The window for selecting a keyboard appears.

```
Please select:
  1 = JP Keyboard
  2 = US Keyboard
Your selection
```

2 Select a keyboard.

Select [1] for Japanese keyboard or select [2] for English keyboard. Japanese keyboard is selected by default.

3 When the DOS Prompt window appears, enter the following command and press the [Enter] key.

```
A:\SMT>SAVE.bat
```

4 If the BIOS information is stored successfully, the following message appears.

```
Success !
```

5 Confirm that the stored information files are created.

Enter the following command to display the stored information files which are created.

```
A:\SMT>dir
```

The BIOS information has been stored. The server can now be turned off safely.

4.3.2 Recovering the BIOS Information

If the information configured with BIOS Setup Utility was deleted due to a drain of the built-in server battery, etc., restore the BIOS information according to the following procedure.



- ▶ Do not turn off the server while a program is running.

- 1** Insert the "Server Management Tools" disk into the floppy disk drive and turn on the server.

The window for selecting a keyboard appears.

```
Please select:
  1 = JP Keyboard
  2 = US Keyboard
Your selection
```

- 2** Select a keyboard.

Select [1] for Japanese keyboard or select [2] for English keyboard. Japanese keyboard is selected by default.

- 3** When the DOS Prompt window appears, confirm that the BIOS stored information files are in the floppy disk.

Enter the following command to confirm that the stored information files are in the floppy disk.

```
A:\SMT>dir
```

- 4** Enter the following command and press the [Enter] key.

```
A:\SMT>REST.bat
```

- 5** If the BIOS information is restored correctly, the following message appears.

```
Success !
```

- 6** The BIOS information will be enabled after the next system restart. Restart the server.

Perform Step 1 to display the DOS Prompt window. The restoration procedure has been completed. The server can now be turned off safely.

4.4 Creating Maintenance Tools and Driver Disks

This section explains how to create the server maintenance tools and driver disks with FloppyBuilder function of ServerStart.

With FloppyBuilder function of ServerStart, you can create the following tools:

- "Server Management Tools" disk
- DOS Diskette

FloppyBuilder can be used under environments such as:

- The ServerStart system started on a client computer (recommended)
- The ServerStart system started from PRIMERGY Startup Disc on the server

POINT

- ▶ When creating the tools on a client computer, it is necessary to install ServerStart on the client computer beforehand.
If ServerStart of a different version is installed on the computer, make sure to uninstall the ServerStart. Then perform installation again. For details on how to uninstall ServerStart, refer to "■ Uninstalling ServerStart" (→pg.82).

4.4.1 Installing ServerStart

Install ServerStart on a client computer when creating a driver disk using FloppyBuilder function.

● System requirements for client computers

Client computers must satisfy the following requirements.

Hardware	Personal computers operated with Windows Vista, Windows XP Professional, or Windows 2000 Professional (A DVD drive and minimum 10MB free disk space are required.)
Software	Microsoft® Internet Explorer 5.5 or later

POINT

Using ServerStart on the server

- ▶ ServerStart can be installed to the server, when using Windows Server 2003. Install ServerStart in accordance with this chapter.
Note that ServerStart is not available to the server where Windows Server 2003 x64 is installed.

- 1** Insert the PRIMERGY Startup Disc into the client computer.
The [PRIMERGY Startup Disc] window appears.

- 2** Click [ServerStart V6.711].
[Fujitsu Siemens ServerStart] window appears.

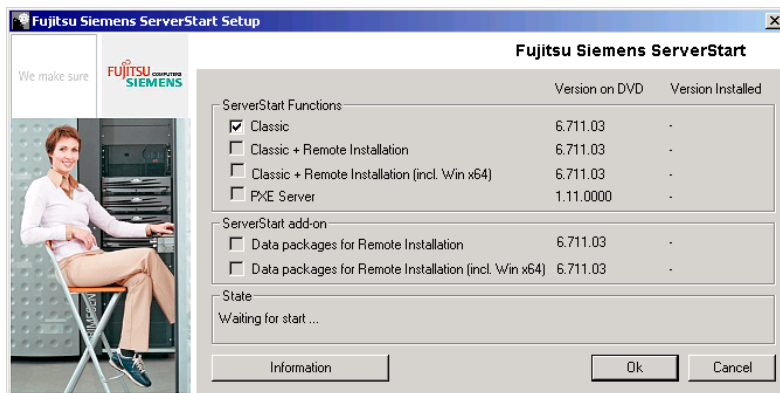

POINT

- ▶ The message "Do you want to run or save this file?" may appear depending the OS in use. Follow as below.
 1. Click [Run].
A message appears that "The publisher could not be verified. Are you sure you want to run this software?"
 2. Click [Run].
Execute "SeStSetup.exe" in the disk when [Fujitsu ServerStart Setup] window does not display.

- 3** Check the checkbox of [Classic] only and click [OK].
The Setup window appears.
- 4** Click [Next].
The [License Agreement] window appears.
- 5** Select [I accept the license agreement] and click [Next].
The [User Information] window appears.

- 6** Enter the user information of the software and click [Next].
The [Destination Folder] window appears.

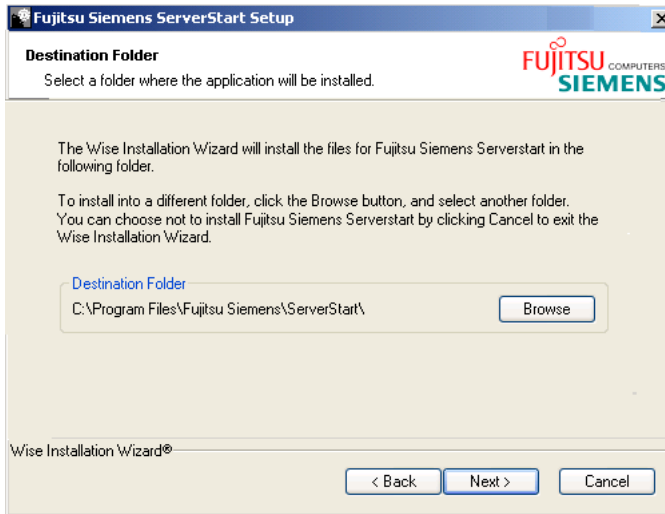

- 7** Specify the installation folder and click [Next]. To change the installation folder, click [Browse] and select the folder.

The [Ready to Install the Application] window appears.

- 8** Click [Next].

Installation is executed.

POINT

- ▶ If a message prompts you to restart the system before or after installation, eject the disc and restart the system according to the message. When the system restarts, insert PRIMERGY Startup Disc and start installation again.
If the "This program does not respond." message appears during restart operation, click [Exit] to continue the restart operation.

When the installation is completed, the completion window appears.

- 9** Click [Exit].

ServerStart has been installed to the client computer.

■ Uninstalling ServerStart

Uninstall ServerStart on the client computer according to the following procedure when necessary.

- 1** Click [Start] – [All Programs] – [Fujitsu Siemens ServerStart] – [Uninstall ServerStart].
- 2** Click [OK].
When the uninstallation is executed successfully, ServerStart is deleted.

4.4.2 Startup Method for FloppyBuilder

Start up ServerStart and FloppyBuilder. Startup methods vary depending on the cases of creating on a client server, or the server.

- **For creation on a client computer**

- 1** Set the PRIMERGY Startup Disc to the client computer.
Once "PRIMERGY Startup Disc" window appears, exit the window.
- 2** Click [Start] – [All Programs] – [Fujitsu Siemens ServerStart] – [ServerStart (Start from DVD)].
ServerStart starts up and the [Welcome to ServerStart] window appears.

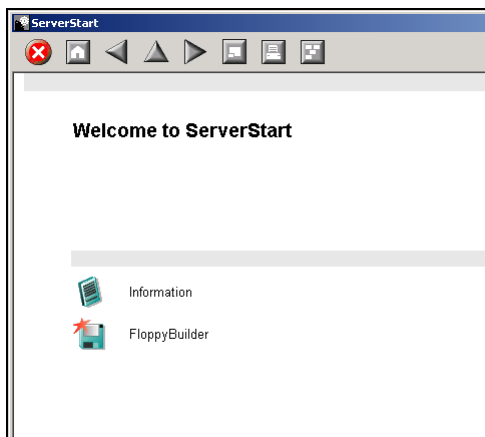

- 3** Click [FloppyBuilder].
The [ServerStart FloppyBuilder] window appears.

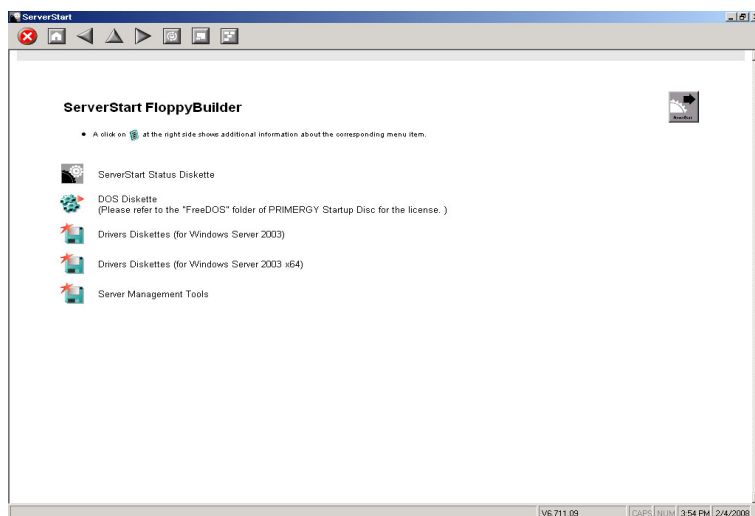

● **For creation on the server**

1 Turn on the power of the server and set PRIMERGY Startup Disc.
ServerStart starts up and select media window for the configuration file appears.

2 Select [RAM Disk] and click [Next].

The [Initialization of ServerStart core running] window appears and the initialization operation launches. In some cases, initialization operation may take a few minutes depending on hardware configuration. After completion, the license agreement window appears.

3 Click [Accept].

The [Welcome to ServerStart] window appears.

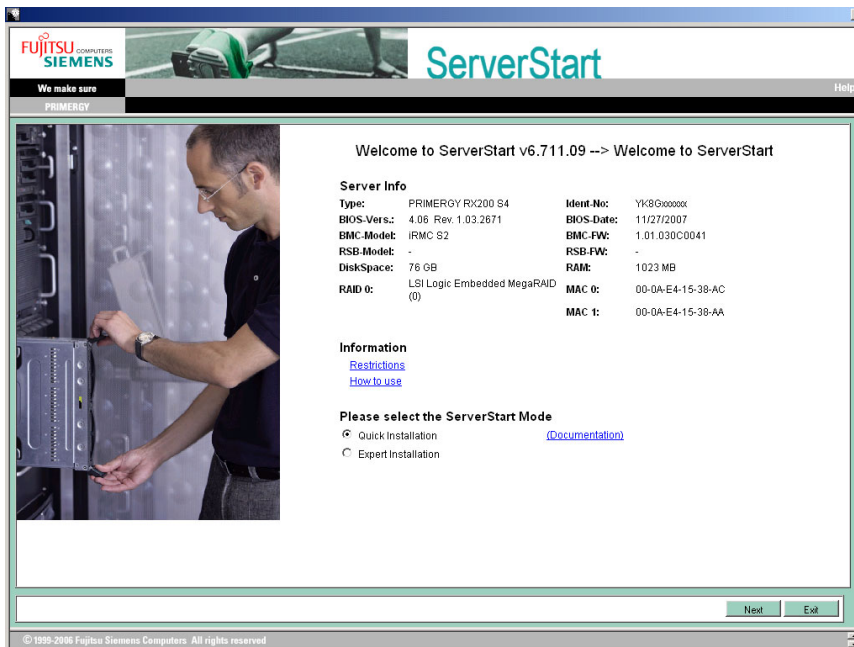

4 Select [Expert Installation] and click [Next].

The [Welcome to ServerStart] window appears.

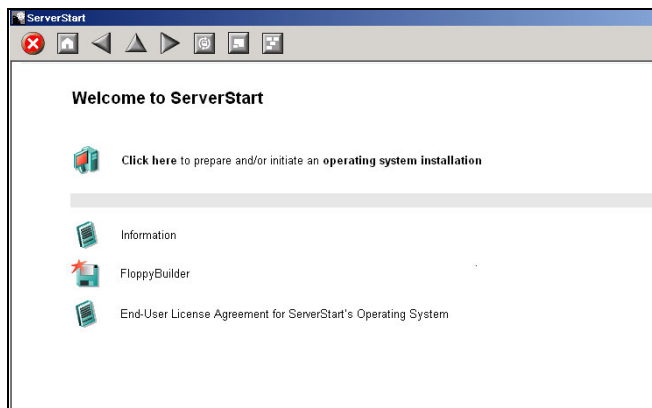

- 5** Click [FloppyBuilder].
The [ServerStart FloppyBuilder] window appears.

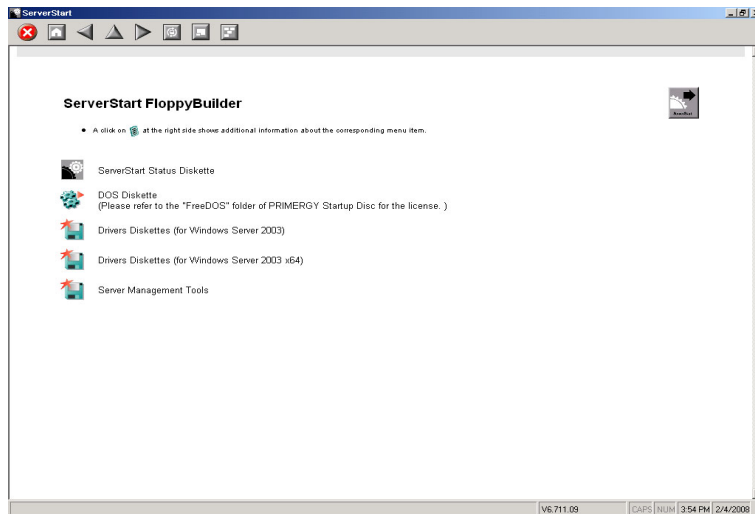

4.4.3 Creating "Server Management Tools" Disk

Start up ServerStart and confirm that the FloppyBuilder window is displayed.

- 1** Click [Server Management Tools].
- 2** Click the tool to be created.
Insert the prepared floppy disk by following the message.
- 3** Perform the subsequent operations according to the messages on the window.
The floppy disk will be formatted automatically and file copying will start.
The respective tools will be created automatically. When a message appears indicating that the disk is created, click [OK] and eject the disk.
- 4** Fill the following items on the label of the floppy disk.
 - The model of the server
 - Version and Level of the Server Management Tools
 - Date of the floppy disk created

4.4.4 Creating Driver Disks

Prepare floppy disks as many as the number of the drivers to be created.

Start up ServerStart and confirm that the FloppyBuilder window is displayed.

- 1** Click [Drivers Diskettes (for Windows Server 2003 / R2)] or [Drivers Diskettes (for Windows Server 2003 x64 / R2 x64)] according to the installed OS.

The [FloppyBuilder Driver Disk] window appears.

- 2** Click the type of the driver to be created.

- 3** Click the driver disk to be created.

Follow the message and insert a floppy disk.

- 4** Perform the subsequent operations according to the messages on the windows.

The floppy disk will be formatted automatically and file copying will start.

The driver disk is automatically created. When a message appears indicating that creating the disk is completed, click [OK] and eject the floppy disk.

4.4.5 Creating a DOS Diskette

For DOS data stored into the floppy disk, refer to the file in the following folder of the PRIMERGY Startup Disc.

[CD/DVD drive]:\FreeDOS

To create a DOS diskette, prepare an unused floppy disk.

Start up ServerStart and confirm that the FloppyBuilder window is displayed.

- 1** Start up ServerStart and click [FloppyBuilder].

- 2** Click [DOS Diskette].

- 3** Perform the subsequent operations according to the messages on the window.

The floppy disk will be formatted automatically and file copying will start.

The DOS diskette will be created automatically. When a message appears indicating that the disk is created, click [OK] and eject the disk.

4.5 Notes before Operating the Server

This section explains the settings required before starting to operate the server. For details on the settings, refer to the following URL.

<http://www.microsoft.com/technet/prodtechnol/exchange/2003/Library/default.msp>

POINT

- ▶ For the settings of the installed application software supplied with the server, refer to the manuals of each of them.

IMPORTANT

- ▶ For notes on the ServerView security, refer to "Security" in "1.1.7 Notes" in the "ServerView User's Guide".

4.5.1 Auto-run Function from CD/DVD Drives

Perform the following procedure to change the settings of the auto-run function from the CD/DVD drives after server installation.

- 1** Make the registry editable, and change the value of AutoRun of the following registry key:
HKEY_LOCAL_MACHINE\System\CurrentControlSet\Services\CDRom
Set the value of AutoRun to "1" to enable auto-run, or to "0" to disable auto-run.
- 2** Restart the system.
The setting is enabled after the system restarts.

4.5.2 Drive Letter Assignment in the Expert Mode

In the Expert mode, assignment of a drive letter to a particular partition arbitrarily is not available. Drive letters specified on Disk Manager in the Expert mode will be sequentially assigned from the first partition with "C, D, E..." when installation is completed, and an unused drive letter will be assigned to the CD/DVD drive. To change the drive letter, perform the following procedures after installation.

IMPORTANT

- ▶ The drive letters for the system and boot drive are not changeable.

- 1** Click [Start] – [Administrative Tools] – [Computer Management].
- 2** Click [Disk Management].
- 3** Right-click the partition to change the letter and click [Change Drive Letter and Path].
The [Change Drive Letter and Path] window appears.
- 4** Click [Edit].
The [Change Drive Letter or Path] window appears.
- 5** Change the drive letter.

4.5.3 Notes on Advanced Uninterruptible Power Supply (UPS)

Note the following cautions when using an advanced uninterruptible power supply (referred to as UPS herein).

■ UPS shutdown time setting

Set a sufficient time interval of UPS power-off time (time from the shutdown command to the actual power-off). If the interval is not adequate, the power will be cut off before system shutdown. It may cause data collapse. For details, refer to the manuals of UPS and the UPS management software.

■ Power supply control by UPS

Change the BIOS settings to turn on the server automatically at power recovery or during scheduled operation using the UPS management software (PowerChute Network Shutdown and PowerChute Business Edition).

- 1** Start up BIOS Setup Utility.
→"7.2.1 Starting and Exiting BIOS Setup Utility" (pg.127)
- 2** Click the [Power] menu and set [Power Failure Recovery] to [Always On].
→"7.2.11 Power Menu" (pg.140)
- 3** Save the changes and exit BIOS Setup Utility.

4.5.4 Turning the Power On via a LAN

You can turn the power on the server from a client (via a LAN) by utilizing the Wakeup on LAN (WOL) function.

IMPORTANT

- ▶ Be sure to install ServerView to control the power supply via a LAN.

POINT

- ▶ When the power cable is disconnected from the server or the server is powered off due to power interruption, restart the server. Unless otherwise, the WOL function will be disabled.
- ▶ Only the onboard LAN is available to correspond to the WOL function for this server. To control power supply via a LAN, connect the onboard LAN and set the onboard LAN adapter bind to "1" for sure.

■ BIOS Setup Utility setting

To manage the power supply via a LAN, start up BIOS Setup Utility, select the [Power] menu – [LAN], and then set it to [Enabled]. The [Enabled] is set as the initial setting.

4.5.5 Other Notes on Operation

■ Unnecessary files

After OS installation is completed, folders named Runonce and Runonce2 may be left in the drive where the OS has been installed. Delete these folders since those are not necessary for the system operation.

■ Automated system operation

When performing automated system operation, enhancement of the safety operation with this server against unexpected accidents is necessary, employing such measures as introducing disaster-prevention provisions and stationing responsible for disaster prevention (such as a security guard or janitor) in the building.

■ Unintentional power-off prevention

It is recommended to employ a dedicated power supply device (such as a power distribution board) to prevent accidental power shut-offs.

4.6 LAN Driver Advanced Setup [Intel[®] PROSet]

"Intel[®] PROSet" is a tool for configuring details on the LAN driver for an onboard LAN and a LAN card. This is used in the following cases.

- Setting up a VLAN using a LAN card
- Performing advanced settings of a LAN card



- ▶ ECONE1 100 S2 can not be used for the Teaming function between the onboard LAN and a LAN card (PG-1853).

4.6.1 Intel[®] PROSet Installation

If the tabs such as [Link], [Teaming], and [VLANs] are not added on the property of LAN adapters which can be selected from the [Device Manager], install Intel[®] PROSet according to the following installation procedure.

- 1** Start up the following file contained in the PRIMERGY Startup Disc.
For Windows Server 2003 x64
[CD/DVD drive]:\DRIVERS\LAN\Intel\APPS\PROSETDX\Winx64\Dxsetup.EXE
For Windows Server 2003
[CD/DVD drive]:\DRIVERS\LAN\Intel\APPS\PROSETDX\Win32\DxSetup.EXE
- 2** Click [Next].
- 3** Select [Accept] and click [Next].
- 4** Select [Driver and Intel[®] PROSet/Advanced Network Service] and click [Next].
- 5** Click [Install].
- 6** Click [Finish].

4.6.2 VLAN

■ Notes

Note the following points when using a VLAN.

- When adding or deleting a VLAN, perform such an operation with "Intel® PROSet". Do not disable or delete a VLAN from the [Device Manager] or [Network and Dial-up Connections].
- Only ten or less VLANs can be set to a LAN port.
- Up to four VLANs whose "NetBIOS over TCP/IP" is enabled in the whole system.
- On a VLAN, only use TCP/IP protocols.
- When LLC and the LNDFC protocols are installed by the Fujitsu communication control service, these protocols are bound (connected) unconditionally. Therefore, release the bind of VLAN and these protocols in the system where these protocols and VLAN are installed at the same time.

■ VLAN configuration procedure

1 Click [Start] – [Administrative Tools] – [Computer Management] to start up Intel® PROSet.

2 Click [Network adapters] under [Device Manager] and double-click a LAN.

3 Click the [VLANs] tab, and click [New...].

4 Specify [VLAN ID] and [VLAN Name]. Then click [OK].

The [VLAN ID] should be identical with the switch setting. The configuration range 1 to 4094 can be specified. Any name can be specified as the [VLAN Name].

5 Click [OK] to close the property window for the LAN adapter.

When setup of the VLAN is completed, the following virtual adapter will be created.

- "(LAN Adapter Name)-VLAN:(VLAN Name)"

Upper protocols will be bound with the main virtual adapter. They can not be bound with the LAN card configuring a VLAN. The IP address should be specified in the main virtual adapter.

Chapter 5

High Reliability Tools

5

For stable PRIMERGY server operations, we recommend that high reliability tools be installed. This chapter explains the installation and necessary settings of high reliability tools.

5.1 RAID Management Tool	94
5.2 Server Monitoring Tool [ServerView]	95
5.3 Maintenance Support Tool [HRM/server]	97
5.4 Solving Problems Early [DSNAP]	98

5.1 RAID Management Tool

RAID management tool performs configuration, initialization and monitoring of the hard disk array. For details, refer to the manual in the Array Controller Document & Tool CD.

POINT

OS installation using ServerStart

- ▶ When the OS has been installed using ServerStart, RAID management tool has been also installed together with the OS as well as other high reliability tools.

■ Before starting operation

Complete the following settings after the OS installation.

For details, refer to the manual in Array Controller Document & Tool CD.

● Configuration of the array administrator account

Set an array administrator account for the RAID management tool (ServerView RAID).

A Windows user account is required when using ServerView RAID.

Create a group named "raid-adm", and an account with any name for an array administrator within the group, "raid-adm".

● Configuration of HDD Check Scheduler

Modify the settings of HDD Check Scheduler if necessary when using a SAS array controller card (MegaRAID SAS) and an Onboard Software RAID (Embedded MegaRAID SATA). It has been set at 12 o'clock every day as a default setting.

● Notification settings for events of failures

This server is not equipped with LEDs which notify you an error or a failure of the installed hard disk units. To receive error or failure notifications in real-time, start up ServerView S2 to complete the necessary setting after installation of ServerView and RAID management tool (ServerView RAID).

For details on the setting procedures, refer to "Appendix C Setting Notifications for Events of Failures" (→pg.177).

5.2 Server Monitoring Tool [ServerView]

ServerView constantly monitors the hardware status of each server in the network, and at the same time, provides a console which enables to recognize the status of all the servers promptly. ServerView keeps the server hardware under monitoring all the time. An error that could cause trouble, if detected, will be notified in real-time. This function helps to remove a system error at earlier stage and avoid troubles.



- ▶ For notes on ServerView security, refer to "Security" in "1.1.7 Note" in the "ServerView User's Guide".

■ Importance of monitoring the server with ServerView

For safe operation of PRIMERGY, perform monitoring of the server using ServerView for sure. Even if the server is operating with a redundancy configuration, overlooking or neglecting errors could result in a system stop or data loss. As soon as one constituent part of the redundancy configuration fails, the corresponding countermeasures must be taken. For that reason, monitoring the server with ServerView is necessary.

If ServerView is not installed, the following serious problems may occur.

● RAID error monitoring

ServerView notifies users of the RAID errors. In an environment where ServerView is not in use, any errors will be notified. Leaving the RAID error unsolved may lead to a system stop caused by multiple hard disk unit malfunctions.

● Memory monitoring

ServerView monitors the memory. In an environment where ServerView is not in use, a memory single-bit error can not be detected during operation. The server must restart as those errors are detected by using Server Management Tools. Leaving this error unsolved may develop to multiple-bit errors and cause a system stop.

● Fan monitoring

ServerView monitors the fan function. In an environment where ServerView is not in use, fan malfunction (failure/stop) can not be detected during operation. The server must restart as those errors are detected by using Server Management Tools. Leaving the malfunction unsolved may lead to overheating inside the server and a system stop.

● Temperature monitoring

ServerView monitors the temperature. In an environment where ServerView is not in use, the increasing temperature inside the server, caused by the fan malfunction as described above, can not be detected to prevent a system failure. The server must restart as those errors are detected by using Server Management Tools.

- **Voltage monitoring**

ServerView monitors the voltage. In an environment where ServerView is not in use, voltage surge cannot be detected during operation. The server must restart as those errors are detected by using Server Management Tools. Voltage surges may result in malfunction or data loss.

- **Power supply monitoring**

ServerView monitors the power supply. In an environment where ServerView is not in use, power supply irregularities cannot be detected during operation. The server must restart as those errors are detected by using Server Management Tools. System stops due to power supply failures cannot be prevented.

5.2.1 Installing ServerView

- **When installed using ServerStart**

When the OS has been installed using ServerStart, ServerView has been also installed together with the OS as well as other high reliability tools.

- **When installed manually (Linux)**

ServerView cannot be installed using ServerStart. To install ServerView manually on a Linux system, refer to "Chapter 2 Installation" in "ServerView User's Guide".



- ▶ Be sure to install SNMP service before installing ServerView.

- **When an error screen appears after ServerView installation (Windows Server 2003 only)**

If Windows Server 2003 Service Pack 1 is applied, the following message may appear on restarting immediately after installing/uninstalling ServerView.

```
In order to protect the computer, this program is terminated by
Windows.
Name: SNMP Service
```

This message does not imply an error. Click [Close Message] to close the message.

5.2.2 Setting Required after Installation

Perform necessary operations after ServerView installation referring to "2.4 Setting after Installation" in "ServerView User's Guide".

5.3 Maintenance Support Tool [HRM/server]

HRM/server supports quick and proper maintenance operation to achieve high server operation stability.

5.3.1 Installing HRM/server

- **When installed using ServerStart**

When the OS has been installed using ServerStart, HRM/server has been also installed together with the OS as well as other high reliability tools.

- **When installed manually (Linux)**

HRM/server cannot be installed using ServerStart.

To install HRM/server manually into a Linux system, refer to "HRM/server for PRIMERGY (Windows/Linux)" at the following location of the PRIMERGY Startup Disc.

[CD/DVD drive]:\PROGRAMS\Japanese2\HRM\iasv_hrm_install.pdf



- ▶ It is necessary to install ServerView to use HRM/server.

5.3.2 How to Use

For system requirements for HRM/server or usage information, refer to "HRM/server for PRIMERGY (Windows/Linux)" at the following location of PRIMERGY Startup Disc.

[CD/DVD drive]:\PROGRAMS\Japanese2\HRM\iasv_hrm_install.pdf

5.4 Solving Problems Early [DSNAP]

DSNAP is a tool for collectively acquiring failure investigation information such as server environment information.

POINT

OS installation using ServerStart

- ▶ When the OS has been installed using ServerStart, DSNAP has been also installed together with the OS as well as other high reliability tools.

5.4.1 Installing DSNAP

● For Windows Server 2003 x64

Copy the following file stored in the PRIMERGY Startup Disc on the hard disk in the server.
[CD/DVD drive]:\PROGRAMS\Japanese\DSNAPx64\DSNAPx64.EXE

● For Windows Server 2003

When installing DSNAP separately, copy the following file stored in the PRIMERGY Startup Disc on the hard disk in the server.
[CD/DVD drive]:\PROGRAMS\Japanese\DSNAP\DSNAP.EXE

5.4.2 How to Use

● For Windows Server 2003 x64

Refer to the following file stored in the PRIMERGY Startup Disc. Use a program such a text editor to open it.
[CD/DVD drive]:\PROGRAMS\Japanese\DSNAPx64\README.TXT

● For Windows Server 2003

Refer to the following file stored in the PRIMERGY Startup Disc. Use a program such a text editor to open it.
[CD/DVD drive]:\PROGRAMS\Japanese\DSNAP\README.TXT

Chapter 6

6

Installing Internal Options

This chapter explains how to install and remove the various hardware options.

6.1	Before Installing Internal Options	100
6.2	Removing and Attaching Covers	102
6.3	Installing Memory Modules	104
6.4	Installing Expansion Cards	108
6.5	Installing Internal Hard Disk Units	115
6.6	Installing 5-inch Internal Options	121

6.1 Before Installing Internal Options

The following types of internal options can be installed in this server.

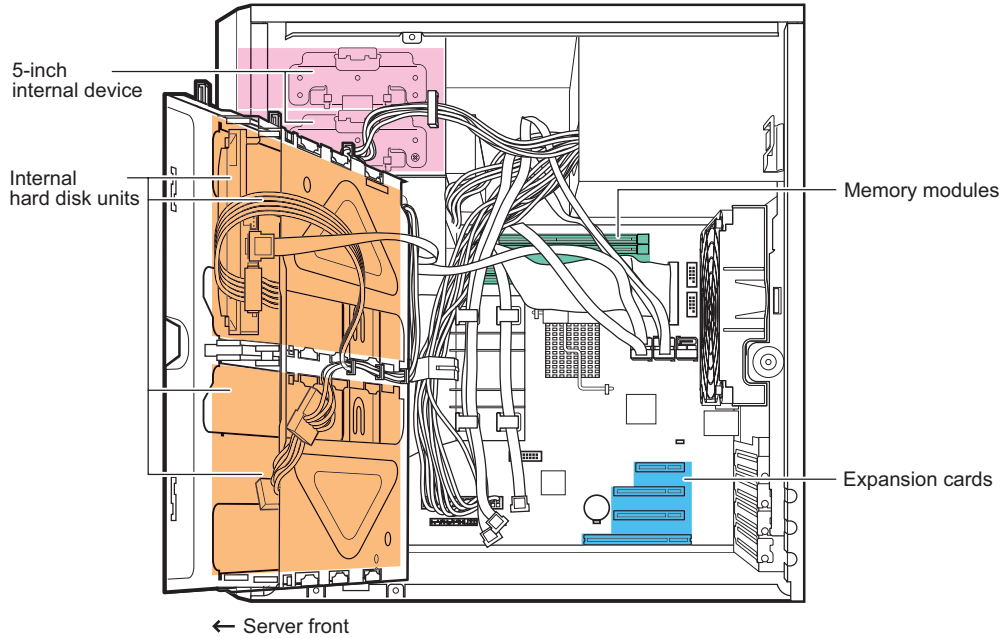

POINT

- ▶ When installing and removing options, make sure to use the removed screws on the same devices that were last installed or removed. Failure to do so can damage the device.
- ▶ The types of optional devices listed in this manual are liable to be updated without any notice. Please be forewarned.
- ▶ When installing optional products (such as internal/external options and USB equipments), be sure to use the products in a system configuration diagram for stable PRIMERGY server operations. Fujitsu does not warrant that the server related products will operate properly if you use the unauthorized third party options.

**WARNING**

Electric Shock

- Before installing/removing internal options to/from the server, turn off the server, all peripheral devices, and any other connected devices. Also unplug all power cables from the outlet. Failure to do so can cause electric shock ("1.4.2 Turning Off the Server" (→pg.29)).
- Do not disassemble the PSU. Doing so can cause electric shocks.



Do not

- Use our genuine internal options only. Failure to do so may cause a device failure, fire, or electric shock.
- Do not damage or modify internal cables or devices. Doing so may cause a device failure, fire, or electric shock.

**CAUTION**

- Devices inside the server remain hot after shutdown. Wait for approximately 10 minutes after shutdown before installing or removing internal options.
- The circuit boards and soldered parts of internal options are exposed. They can be damaged by static electricity. Before handling them, first touch a metal part of the server to discharge static electricity.
- Do not touch the circuitry on boards and soldered parts. Hold the metallic areas or the edge of the circuit boards.
- When installing an internal device, make sure to avoid pinching cables.
- If devices are installed or disassembled by other methods than those outlined in this chapter, the warranty will be invalidated.

6.2 Removing and Attaching Covers

Remove covers to install peripheral devices. Perform the following procedures to remove the cover.



Electric Shock • Before removing or attaching covers, turn off the server, all peripheral devices, and any other connected devices. Also unplug all power cables from the outlet. Failure to do so can cause electric shock ("1.4.2 Turning Off the Server" (→pg.29)).

6.2.1 Removing Covers

- 1** Turn off the server and connected devices, and unplug all power cables from the outlet.
- 2** Pull up the latch of the side cover (1), and pull it outward to remove it (2).

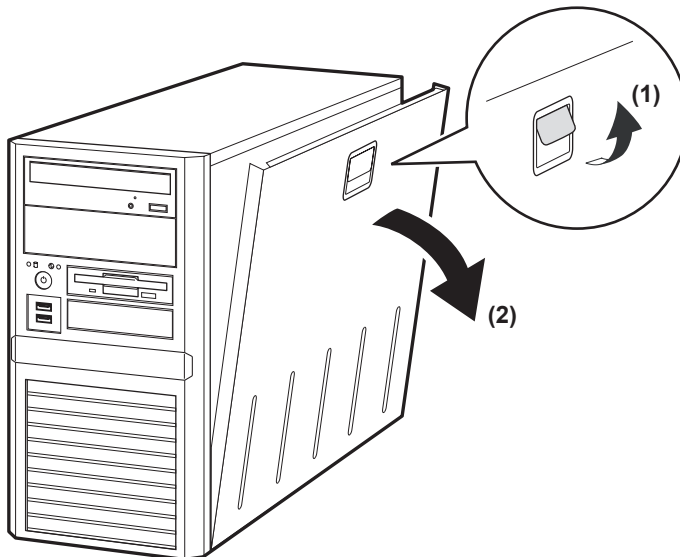

■ Attaching the covers

To attach the side cover, simply reverse the removal procedure.

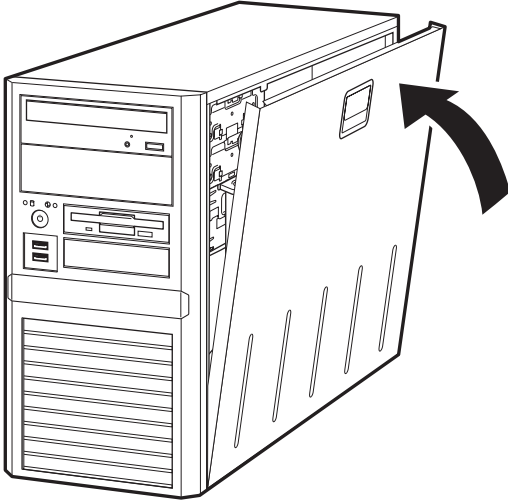

 CAUTION



- Before turning on the server, make sure that all covers are in place.



- Before attaching the side cover, make sure no tools or unnecessary components are left inside the server.

6.3 Installing Memory Modules

Additional memory modules will help to increase the amount of data that can be read at a time and improve the server processing capability.



WARNING



Electric Shock

- When installing or removing memory modules, turn off the server, all peripheral devices, and any other connected devices. Also unplug all power cables from the outlet.

Failure to do so can cause electric shock.

- Use our genuine memory modules only.

Failure to do so may cause a device failure, fire, or electric shock.



- Wait for a sufficient period of time after server shutdown before installing or removing memory.

Failure to do so can cause burns.



CAUTION



Injury

- When installing or removing memory, make sure to remove the screws at the specified locations only. There is a risk of injury if screws other than those at the specified locations are removed. This could also damage the server.



- Touch only the specified part of the printed circuit board.

Failure to do so could cause injury or damage the server.



- Memory modules are made of delicate components that are extremely sensitive to static electricity, and they can be destroyed by static electricity from your clothes or body. Before handling them, first touch some metallic object to discharge static electricity.

- Do not insert and remove memory modules repeatedly. This could damage the server.

- Hold the edges of the memory module, as shown in the figure below. Do not touch the gold contacts and memory chip.

Do not touch here

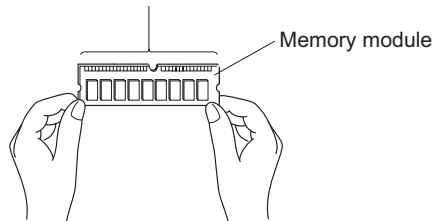

6.3.1 Installation Location of Memory Modules

Install memory modules to the memory slots inside the server.

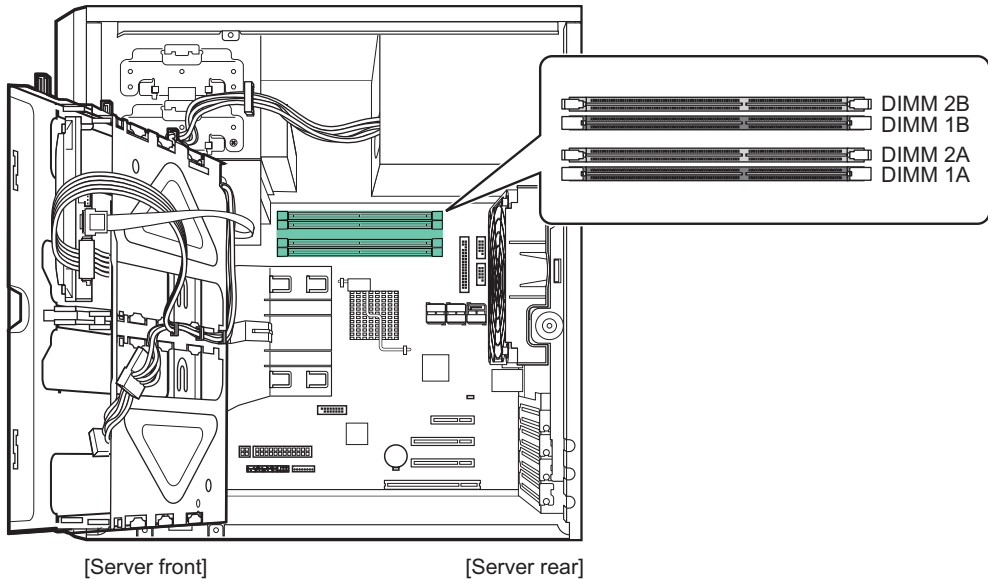

- DIMM1A: the RAM module which is installed as standard feature
- DIMM2A, DIMM1B, and DIMM2B: additional expandable RAM modules

■ Installation order

Install the memory modules in ascending order of memory capacity from the memory slot DIMM1A, DIMM1B, DIMM2A, to DIMM2B.

6.3.2 Installable Memory Modules and Notes

■ Installable memory modules

Installable memory modules are listed below.

table: Installable memory modules

Product name (Product ID)	Remarks
Memory Module-512MB (PG-RM51BH)	512MB (512MB-DIMM × 1)
Memory Module-1GB (PG-RM1BH)	1GB (1GB-DIMM × 1)
Memory Module-2GB (PG-RM2BH)	2GB (2GB-DIMM × 1)

POINT

- ▶ Before installation, refer to "B.1 Memory" (→pg.174) to check the packaged contents.

6.3.3 How to Install Memory Modules

- 1** Turn off the server and connected devices, and unplug all power cables from the outlet.
- 2** Remove the side cover.
→"6.2 Removing and Attaching Covers" (pg.102)
- 3** Lay the server on its side.
- 4** Touch a metal part of the server to discharge static electricity.
- 5** Open an hard disk cage.
Loosen the screws that fix the hard disk cage (1), and open the cage to the front (2).

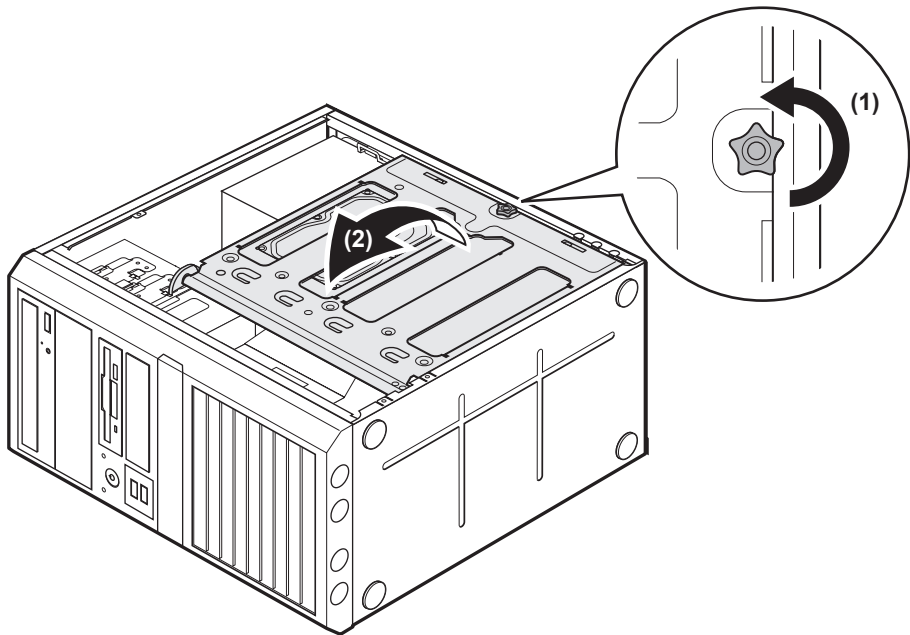

6 Remove and install a memory module.When installing a memory module

Open the retention clips on both sides of the slot and insert the memory module.

Align a notch of the memory module to correspond with the memory slot and insert the module perpendicularly to the slot.

When the module is correctly inserted, the retention clips on both sides will close. Then, check that they secure the memory module. If the retention clips are not securely closed, push them with your fingers to close.

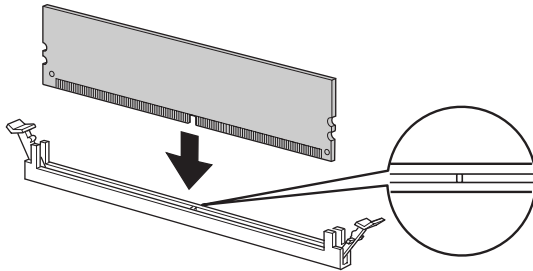

- If the memory module has not been correctly inserted, it may cause a fire. Insert the memory module with attention to its direction.

When removing a memory module

Open the retention clips outward on both sides of the slot and remove the memory module.

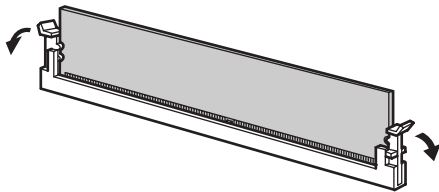

- If a memory module is installed and you pull the retention clips strongly outwards, the memory module pops up. Doing so may cause a device failure.

7 Put the hard disk cage to the place that you removed it from, and fix it with screws.

When you put it back, be careful not to pinch the cable.

8 Put the server lengthwise.**9** Attach the side cover.

6.4 Installing Expansion Cards

This section explains the types of expansion cards, notes and installation procedures.



Electric Shock

- When installing or removing an expansion card, turn off the server, all peripheral devices, and any other connected devices. Also unplug all power cables from the outlet. Failure to do so can cause electric shock.
- Install our genuine expansion cards only. Failure to do so may cause a device failure, fire, or electric shock.



- Expansion cards are susceptible to static electricity. Place them on conductive pads or keep them in their packaging as long as they are not necessary.



- The circuit boards and soldered parts of internal options are exposed. They can be damaged by static electricity. Before handling them, first touch a metal part of the chassis to discharge static electricity.
- Do not touch the circuitry on boards or soldered parts. Hold the metallic areas or the edges of the circuit boards.

6.4.1 Installation Location of Expansion Cards

This server has four PCI slots. PCI slot 2 is not supported.

The specifications are different depending on the PCI slot number.

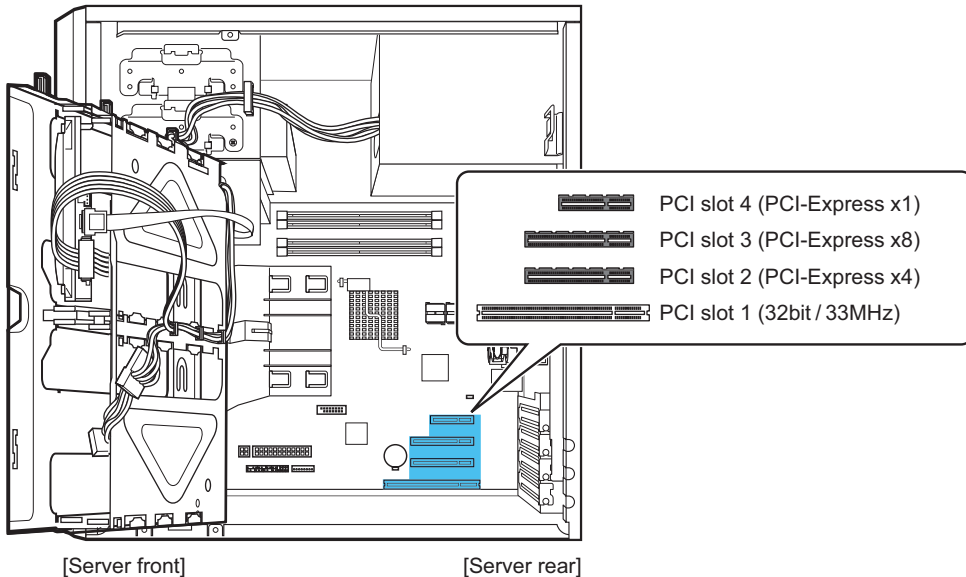

6.4.2 Installable Expansion Cards and Notes

■ Installable expansion cards and slots

Each of the following expansion cards can be installed.

table: Expansion card installation order and slots

Product name (Produce ID)	PCI slot				Remarks
	1	2	3	4	
SAS RAID Ctrl w/ Cable (PG-248BC)	—	—	1	—	MegaRAID SAS, (cache capacity: 256MB)
Eth. Ctrl 1x1Gbit PCI 1000-BASE-T (PG-1853)	1	—	—	—	1000BASE-T, PCI-X
Parallel Port (PG-PP08)	—	—	—	1	

■ Notes on installing expansion cards

- Install installable expansion cards only.
- Before installing an expansion card, refer to the manual supplied with the options and observe the related notes. Further, observe the notes below.

● SAS RAID Ctrl w/ Cable (PG-248BC)

When a SAS array controller card is installed, a connecting cable for an internal hard disk unit must be connected to the SAS array controller card. A connecting cable to an internal hard disk is supplied with SAS array controller card.

→"6.4.4 When a SAS Array Controller Card is Installed" (pg.112)

● Parallel Port (PG-PP08)

To install a parallel port option, change the setting in BIOS Setup Utility.

1 Start up BIOS Setup Utility.

→"7.2.1 Starting and Exiting BIOS Setup Utility" (pg.127)

2 Select the [Advanced] menu – the [Peripheral Configuration] submenu, and change the setting of [Parallel port] to [Auto].

→"7.2.5 Peripheral Configuration Submenu" (pg.133)

6.4.3 How to Install Expansion Cards

1 Turn off the server and connected devices, and unplug all power cables from the outlet.

2 Remove the side cover.

→"6.2 Removing and Attaching Covers" (pg.102)

- 3** Lay the server on its side.
- 4** Touch a metal part of the server to discharge static electricity.
- 5** Open the hard disk cage.

Loosen the screws that fix the hard disk cage (1), and open the cage to the front (2).

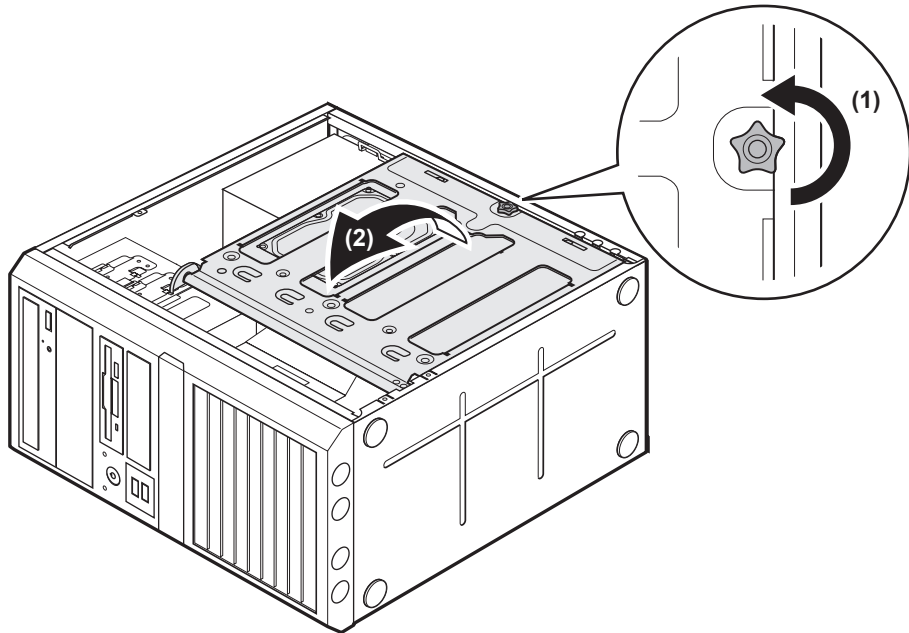

- 6** Loosen the screws that fix the slot cover, and remove it.

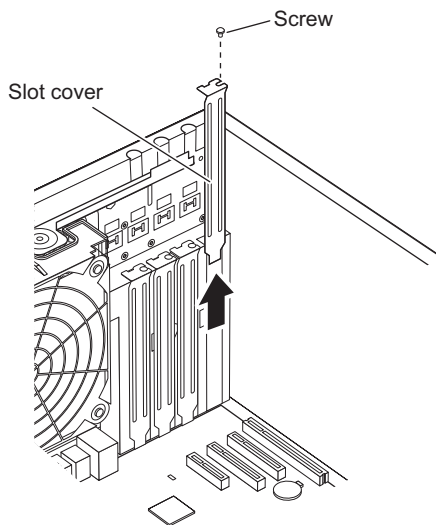

POINT

- ▶ Be sure to keep the removed slot cover for later use.
If operating the server with no expansion cards, attach the slot cover to keep dust away.

- 7** Press the expansion card firmly into the connector of the PCI slot, and fix it with screws.

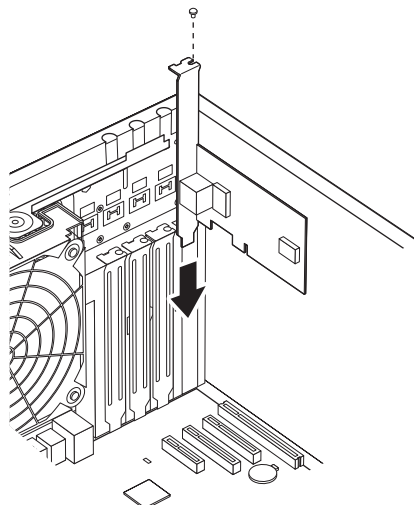

When installing Parallel Port (PG-PP08)

Connect the parallel cable to the parallel port connector on the baseboard. For the parallel port connector location, refer to "1.3.4 Baseboard" (→pg.26).

When installing SAS RAID Ctrl w/ Cable (PG-248BC)

Connect the internal hard disk cable to the SAS array controller card. For details, refer to "6.4.4 When a SAS Array Controller Card is Installed" (→pg.112).

- 8** Put the hard disk cage to the place that you removed it from, and fix it with screws.
When you put it back, be careful not to pinch the cable.
- 9** Put the server lengthwise.
- 10** Attach the side cover.

■ Removing expansion cards

To remove the expansion cards, simply reverse the installation procedure.

6.4.4 When a SAS Array Controller Card is Installed

After SAS array controller card installation, an internal hard disk unit cable must be connected to the SAS array controller card. The setting values of BIOS Setup Utility are also required to be reconfigured.

- 1** Disconnect the internal hard disk unit cable (SATA cable) that is connected to the baseboard.
Disconnect all the SATA cables that are connected to SATA connector 1 through 4.
Disconnect, also, the SATA cables that are connected to the internal hard disk units.
- 2** Connect the SAS cable, which is supplied with the SAS array controller card, to the SAS-MLC1 connector of the SAS array controller card.

[SAS array controller connection]

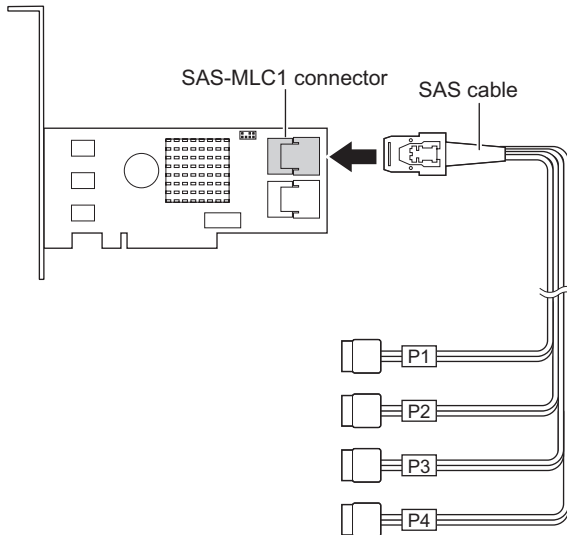

3 Connect the SAS cable to the internal hard disk unit.

Match the slot numbers of the 3.5-inch storage bays with the SAS cable numbers by referring to the table below.

table: Correspondence between slot numbers and SAS cables

Item	Number			
Slot number	0	1	2	3
SAS cable	P1	P2	P3	P4

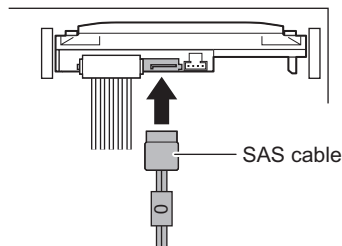

After the connection, bind the SAS cables to the hard disk cage as shown below.

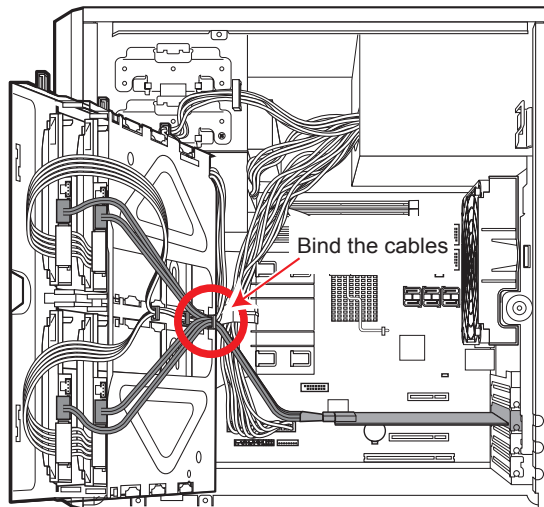
**4** Put the hard disk cage to the place that you removed it from, and fix it with screws.

When you put it back, be careful not to pinch the cable.

5 Put the server lengthwise.**6** Attach the side cover.**7** Turn on the server and start up BIOS Setup Utility.

→"7.2.1 Starting and Exiting BIOS Setup Utility" (pg.127)

- 8** Select the [Advanced] menu – the [Advanced System Configuration] submenu, and change the settings of [SATA RAID Enable] and [SATA AHCI Enable] to [Disabled].
→ "7.2.6 Advanced System Configuration Submenu" (pg.134)
- 9** Press the [F10] key to save the modified configuration, and exit BIOS Setup Utility.
- 10** Start up BIOS Setup Utility again, and select the [Boot] menu to check the settings of [BIOS priority order].
The successful installation will display "PCI SCSI: (Bus01 Dev00)PCI RAID Ad".

 **POINT**

- ▶ After changing the settings of BIOS, store the changed system configuration information.
→ "4.3 Storing the System Configuration Information" (pg.77)

6.5 Installing Internal Hard Disk Units

This section explains how to install internal hard disk units.



WARNING



Electric Shock

- When installing or removing internal hard disk units, turn off the server, all peripheral devices, and any other connected devices. Also unplug all power cables from the outlet (→"1.4.2 Turning Off the Server" (pg.29)).



CAUTION



- When the hard disk unit is starting up, you may hear a resonant noise for a while, but this does not mean a failure.
- Depending on the OS, you can configure the write cache settings for the hard disk drives. However, disable the write cache for use in this server. If the power failure should occur while the write cache is enabled, cached data may be lost.
- When disposing of, transferring, or returning a hard disk unit, wipe out the data on the hard disk for your own security. Contact an office listed in the "Contact Information" of "Start Guide" regarding repairs of the hard disk units.
- Rough handling of hard disk units can damage the stored data. To cope with any unexpected problems, always back up important data. When backing up data to another hard disk drive, you should make backups on a file or partition basis.
- Use the unit in a dry place with low dust levels.
- Be careful not to hit the hard disk unit or bring it into contact with metallic objects.
- Use and store the unit in a shock and vibration free environment.
- Keep the unit away from direct sunlight and from radiators or other heat sources.
- Do not use or store the unit in extremely hot or cold location, or locations with extreme temperature changes.
- Do not disassemble hard disk units.



6.5.1 Installation Location of Internal Hard Disk Units

Install internal hard disk units to 3.5-inch storage bays of the internal hard disk cage.

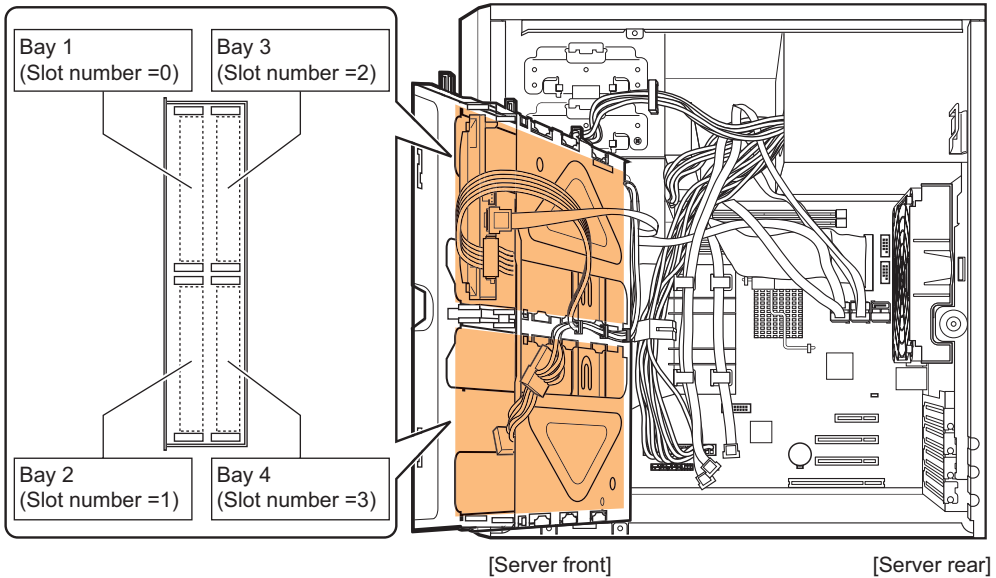

The installation locations for 3.5-inch storage bays have slot numbers that are displayed in RAID management tool.

■ Installation order

Install the internal hard disk units in the ascending order from bay 1 to bay 4.

6.5.2 Installable Internal Hard Disk Units and Notes

Before installing an internal hard disk unit, observe the following notes.

■ Installable internal hard disk units

table: Installable internal hard disk units

Product name	Product ID
HDD SATA 7.2k 80GB 3.5inch	PG-HDE87A
HDD SATA 7.2k 160GB 3.5inch	PG-HDE67A
HDD SATA 7.2k 500GB 3.5inch	PG-HDE57A

POINT

- ▶ Before installation, refer to "B.2 Internal Hard Disk Units" (→pg.174) to check the packaged contents.

IMPORTANT

- ▶ This server does not support hot plug function. Make sure to turn off the server when replacing internal hard disk units.

6.5.3 How to Install Internal the Hard Disk Units

- 1** Turn off the server and connected devices, and unplug all power cables from the outlet.
- 2** Remove the side cover.
→ "6.2 Removing and Attaching Covers" (pg.102)
- 3** Lay the server on its side.
- 4** Touch a metal part of the server to discharge static electricity.
- 5** Open the hard disk cage.
Loosen the screws that fix the hard disk cage (1), and open the cage to the front (2).

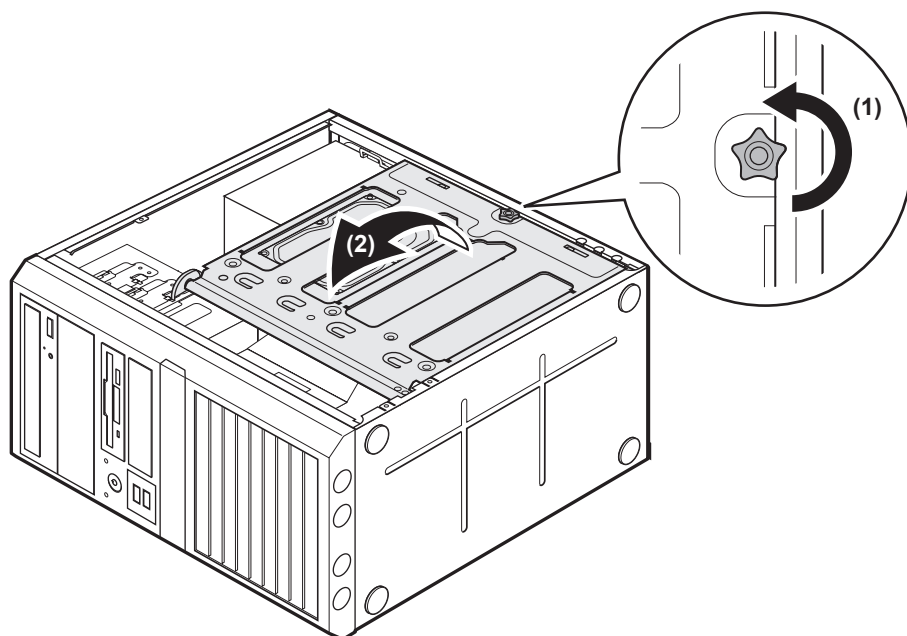

- 6** Remove the hard disk rails from the bay to install the internal hard disk unit.

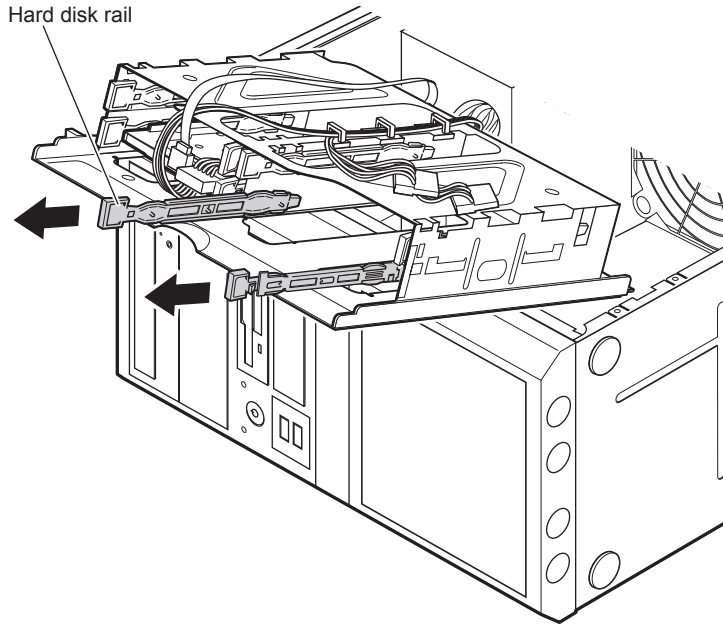

- 7** Attach the rails to the internal hard disk unit.

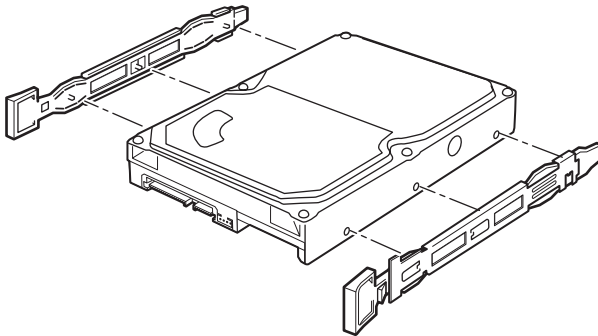

- 8** Install the hard disk unit in the internal hard disk bay.

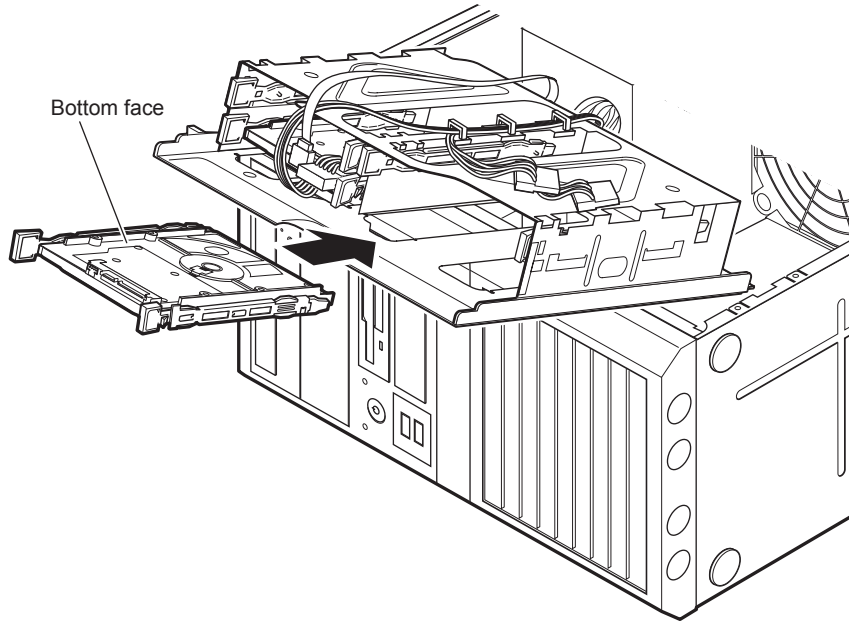

- 9** Connect the internal hard disk cable (SATA cable or SAS cable), and the power cable.

For SATA cable

The slot numbers are marked on the cable ends. Connect the SATA cable with the matching slot number.

For SAS cable

The following table shows the correspondence between slot numbers and SAS cables. Match them by referring to the table.

[table: Correspondence between slot numbers and SAS cables](#)

Item	Number			
Slot number	0	1	2	3
SAS cable	P1	P2	P3	P4

For power cable

Connect a power cable as shown in the figure below.

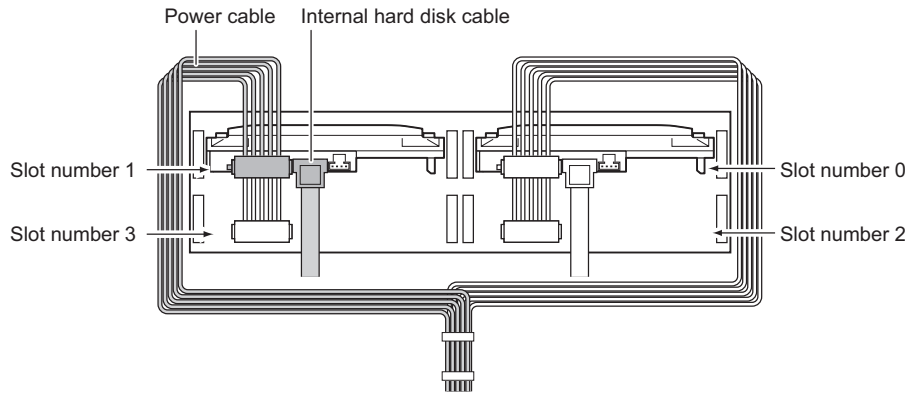

- 10** Put the hard disk cage to the place that you removed it from, and fix it with screws.
When you put it back, be careful not to pinch the cable.
- 11** Put the server lengthwise.
- 12** Attach the side cover.

■ **How to remove the internal hard disk unit**

To remove an internal hard disk, simply reverse the installation procedure.

6.6 Installing 5-inch Internal Options

This section explains how to install a 5-inch internal device option.



WARNING



Electric Shock

- When installing or removing internal devices, turn off the server, all peripheral devices, and any other connected devices. Also unplug all power cables from the outlet.
Failure to do so can cause electric shock.
- Install our genuine internal devices only.
Failure to do so may cause a device failure, fire, or electric shock.



CAUTION



- When installing or removing hardware options, make sure to remove the screws on the specified points only.
There is a chance of injury if screws other than those on the specified points are removed. This could also damage the server.



- Touch only the specified part of the printed circuit board. Failure to do so could cause injury and also damage the server.

POINT

- ▶ Before installing a 5-inch internal device option, install the OS and turn off the server once.

6.6.1 Installation Location of 5-inch Internal Devices

Install a 5-inch internal device option to 5-inch storage bay.

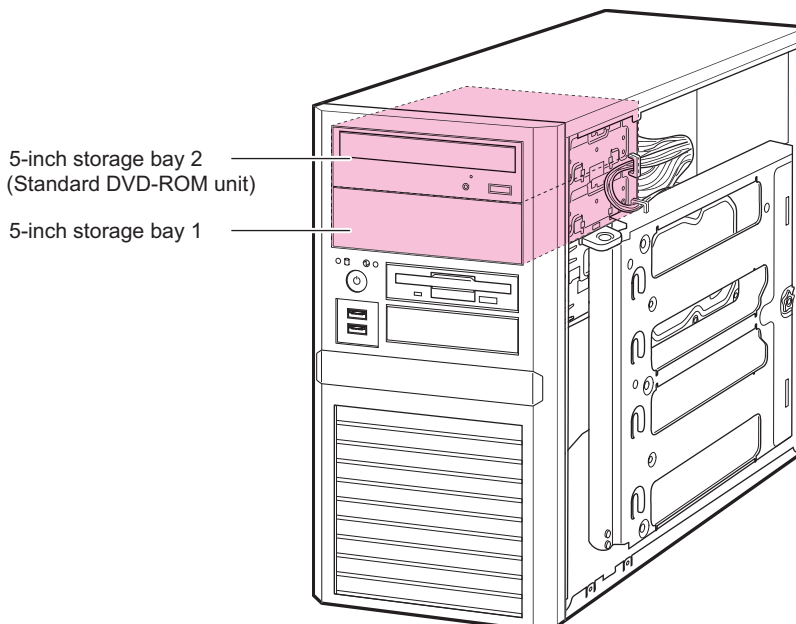

6.6.2 Installable 5-inch Internal Devices

One of the following internal 5-inch device options can be installed in the server.

table: Installable 5-inch internal device options

Product name	Product ID	Cable (separate)	SCSI ID
Tape Drv DAT72 36GB internal	PG-DT5043	PG-CBLU005	—
Internal Data Cartridge Drive Unit	PG-RD1021	PG-CBLU005	—

6.6.3 How to install 5-inch Internal Devices

Follow the procedure below to install a 5-inch internal device option.

- 1** Turn off the server and connected devices, and unplug all power cables from the outlet.
- 2** Remove the side cover.
→"6.2 Removing and Attaching Covers" (pg.102)
- 3** Touch a metal part of the server to discharge static electricity.
- 4** Remove the dummy unit.
Remove the two screws that fix the 5-inch storage bay, and pull it out slowly.

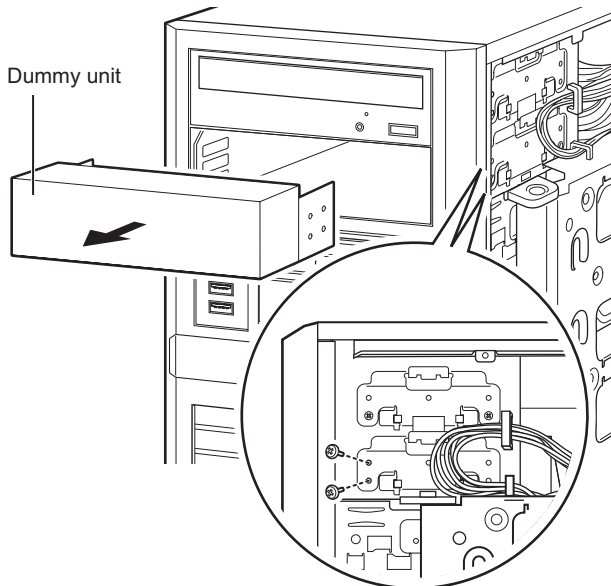

POINT

- ▶ Be sure to keep the removed dummy unit for later use.

5 Install a 5-inch internal device option with two screws to the 5-inch storage bay.

Example: For Tape Drv DAT72 36GB internal

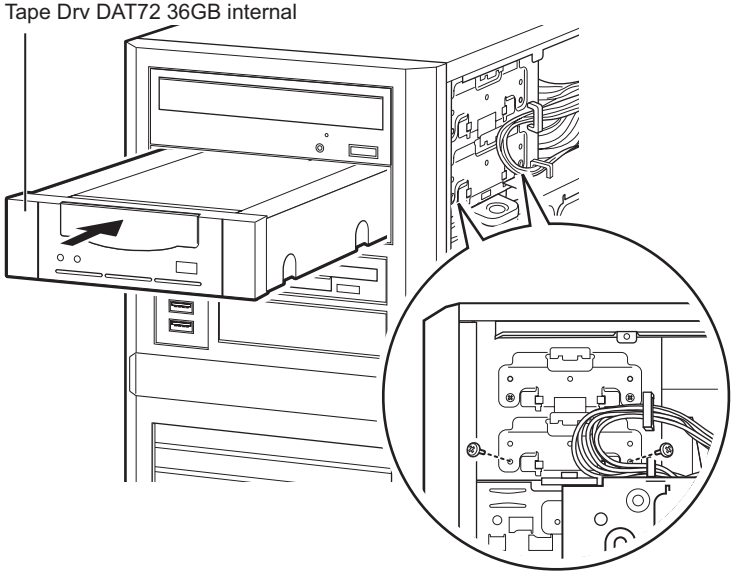

6 Lay the server on its side.

7 Open the hard disk cage.

Loosen the screws that fix the hard disk cage (1), and open the cage to the front (2).

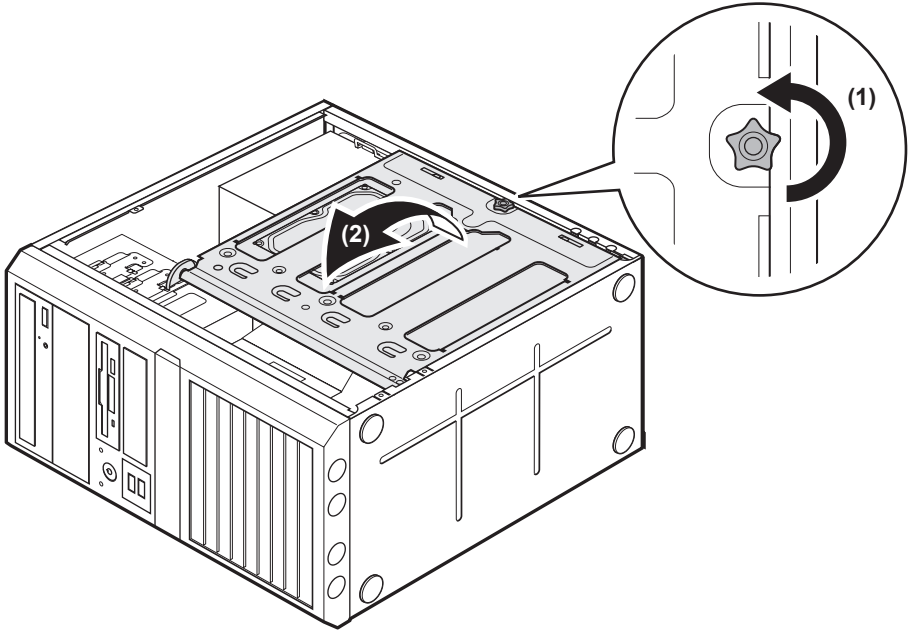

- 8** Connect the power cable and the USB cable to the 5-inch internal device option.

Connect the USB cable to the power cable inside the server.

For Tape Drv DAT72 36GB internal

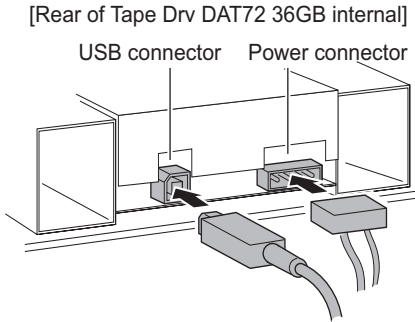

For Internal Data Cartridge Drive Unit

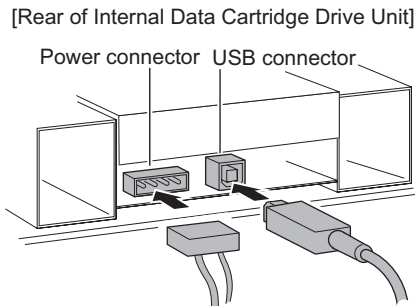

- 9** Connect the USB cable to the baseboard.

For the connection location, refer to "1.3.4 Baseboard" (→pg.26).

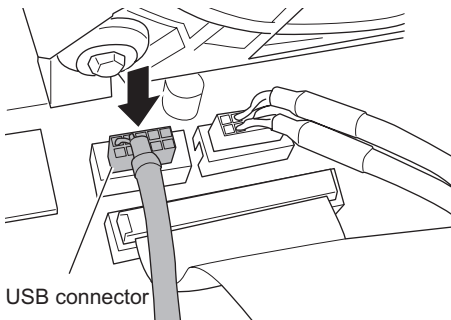

- 10** Put the hard disk cage to the place that you removed it from, and fix it with screws.

When you put it back, be careful not to pinch the cable.

- 11** Put the server lengthwise.

- 12** Attach the side cover.

7

Chapter 7

Configuring Hardware and Utilities

This chapter explains how to make the environment settings necessary to operate the server and how to use each utility.

7.1 Jumper Settings	126
7.2 BIOS Setup Utility	127

7.1 Jumper Settings

This section explains jumper settings.

■ Jumper location

The jumper of the server is located on the baseboard as shown below.

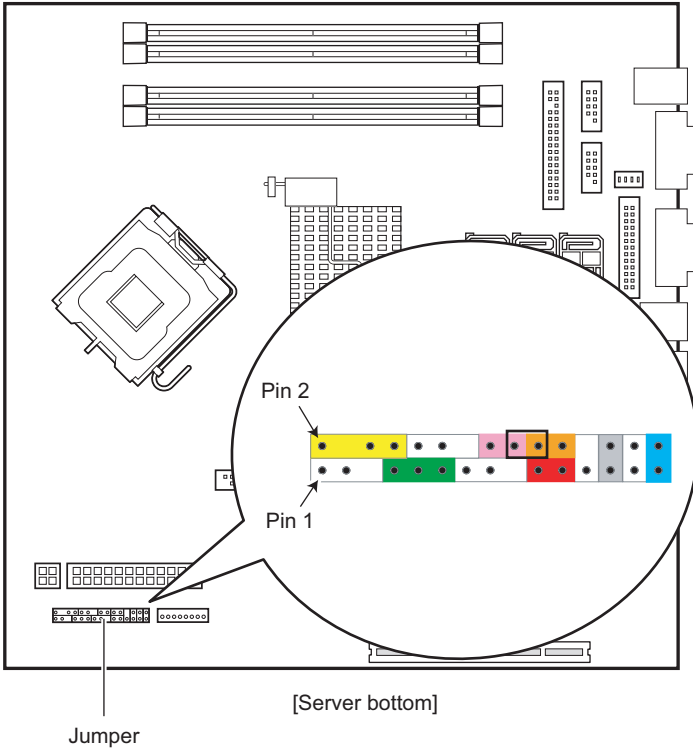

■ Jumper settings

The jumper settings are as shown below.

table: Jumper settings

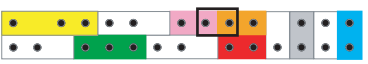
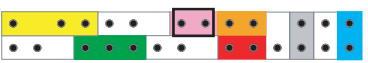
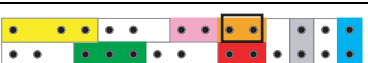
Key	Meaning	Description
 <p>[Server bottom]</p>	Standard Location	It is the standard location. Put the jumper back to the standard location after operation.
 <p>[Server bottom]</p>	Password Skip	When a password has been set, BIOS Setup Utility starts up without password authentication.
 <p>[Server bottom]</p>	BIOS Recovery	The BIOS setting values will be recovered by using the recovery floppy disk.

7.2 BIOS Setup Utility

This section explains settings for BIOS Setup Utility and items regarding each setting.

7.2.1 Starting and Exiting BIOS Setup Utility

The following explains how to start up and exit BIOS Setup Utility.

■ How to start up BIOS Setup Utility

- 1** Turn on the server.
- 2** During POST, press the [F2] key while the message "<F2> BIOS Setup / <F12> BOOT Menu" is displayed on the screen.
The [Main] menu screen appears when POST completes.

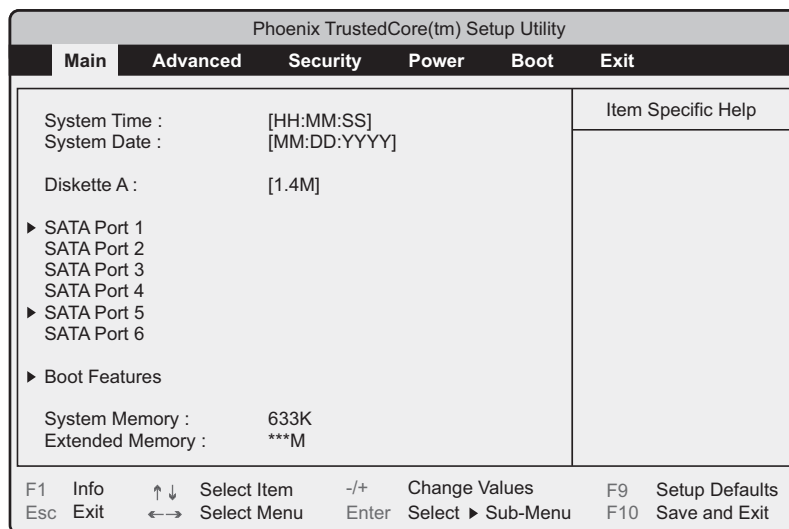

POINT

When the [Main] menu screen does not appear

- ▶ When the [Main] menu screen does not appear because the [F2] is pressed at wrong timing, press the [Ctrl] + [Alt] + [Delete] keys at the same time to restart the system, then start up BIOS Setup Utility.

POINT

- ▶ While the message "<F2> BIOS Setup / <F12> BOOT Menu" is displayed, pressing the [F12] key displays the [Boot] menu screen when POST completes.
→ "7.2.12 Boot Menu" (pg.141)

● Key operations in BIOS Setup Utility

The functions of the keys used for setting BIOS Setup Utility are as follows.

table: List of key operations on the BIOS Setup Utility screens

Key	Description
[F1]	Displays the system information. Press the [Esc] key to close.
[Esc]	Ends a submenu and returns to the previous menu. Or displays the [Exit] menu.
[↑][↓]	Scrolls through the menu option list.
[←][→]	Switches menus.
[-][+]	Changes the values of an item.
[Enter]	Selects an item. For items with ►, the submenu appears.
[F9]	Sets the configured value of each item to its default value.
[F10]	Saves the value of each item and exits BIOS Setup Utility.

IMPORTANT

- ▶ Note the following points to return the configured values to the default values with the [F9] key.
 - When an Onboard Software RAID is not used, confirm that [SATA RAID Enable] and [SATA AHCI Enable] are [Disabled] on the [Advanced System Configurations] submenu of the [Advanced] menu. If not, the system may not start up.
 - When an Onboard Software RAID is used, confirm that the startup priority has been set properly on the [Boot] menu. When the priority of CD/DVD drive is low, startup from the CD/DVD drive may fail.

■ How to exit BIOS Setup Utility

- 1 Use the [←] [→] keys to display the [Exit] menu.

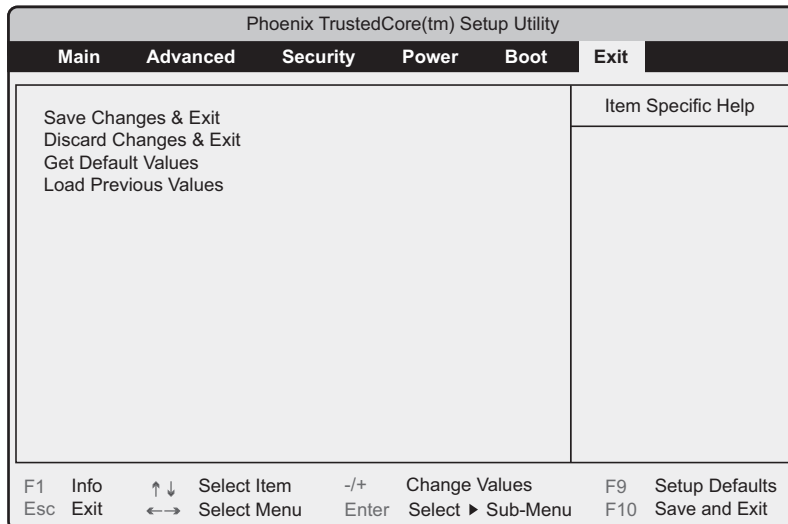

2 Use the [↑] [↓] keys to select the exit mode.To save configuration changes before exiting:

Select [Save Changes & Exit] and press the [Enter] key.

The message "Save configuration changes and exit now?" is displayed.

To exit without saving configuration changes:

Select [Discard Changes & Exit] and press the [Enter] key.

When the settings are changed, the "Configuration has not been saved! Save before exiting?" message is displayed.

3 Use the [←] [→] keys to move the cursor to [Yes] or [No], and press the [Enter] key.If you select [Save Changes & Exit] on the [Exit] menu:

- Select [Yes] to exit.
After saving changes, BIOS Setup Utility exits and the server restarts.
- Select [No] to continue.
The display returns to the BIOS Setup Utility screen.

If you select [Discard Changes & Exit] on the [Exit] menu:

- Select [Yes] to save changes before exiting.
BIOS Setup Utility exits and the server restarts.
- Select [No] not to save changes.
BIOS Setup Utility exits and the OS starts.

7.2.2 Main Menu

The [Main] menu appears when you start up BIOS Setup Utility.

Use this menu to set the time and date, and configure the drives.

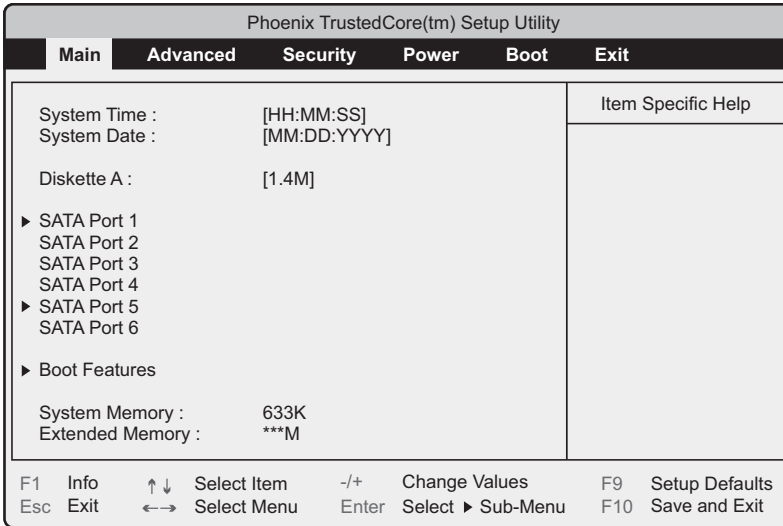

table: Items on the Main menu

Item	Setting	Description
System Time	Present time	The system time is set in "hours:minutes:seconds" format. The hours should be based on a 24-hour clock. For example, 6:30:00 P.M. is set as "18", "30", "00". If a highly precise system time is necessary, install a network synchronized time system (NTP, etc.).
System Date	Present date	The system date is set in "month:day:year" format. For example, December 25, 2007 is set as "12", "25", "2007".
Diskette A	1.4M (Unchangeable)	The type (recording density and drive size) is set for Floppy Disk Drive A.
SATA Port 1 to 6		Pressing the [Enter] key displays the [SATA Port] submenu which shows the device capacity, LBA Mode, DMA transfer mode, the version of the firmware and so on. The submenu is displayed only for SATA port in use.
Boot Features		Configures the system startup settings. Pressing the [Enter] key displays the "7.2.3 Boot Features Submenu" (→pg.131) screen.
System Memory		Displays available system memory size less than 1MB.
Extended Memory		Displays available system memory size larger than 1MB.

7.2.3 Boot Features Submenu

Use this submenu to set system startup options.

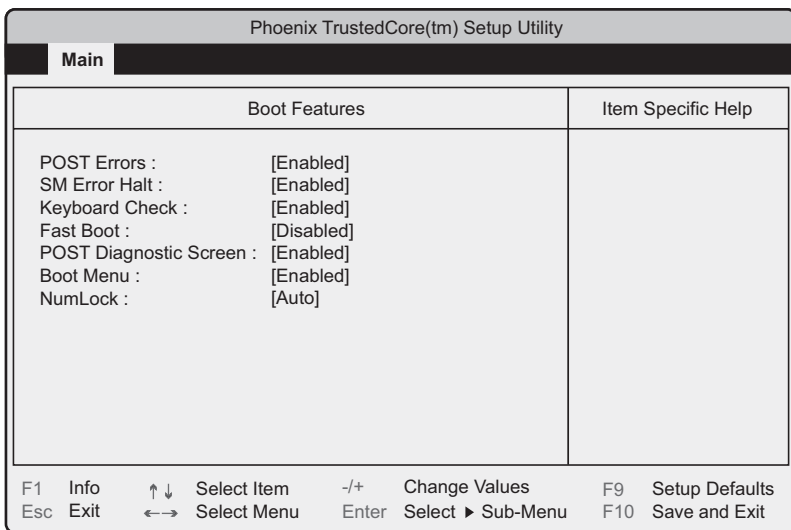

table: Items on the Boot Features submenu

Item	Setting	Description
POST Errors	Enabled (Unchangeable)	Sets whether to stop the boot process and shut down the system, in case a POST (Power On Self Test) error is detected.
SM Error Halt	Enabled (Unchangeable)	Sets whether to interrupt the system boot when errors in the fans or the temperature sensor occur.
Keyboard Check	<ul style="list-style-type: none"> • Disabled • Enabled (Initial value) 	Sets whether to check keyboard connection during POST.
Fast Boot	Disabled (Unchangeable)	Sets whether to reduce the scope of POST and thereby speed up system startup.
POST Diagnostic Screen	Enabled (Unchangeable)	Sets whether to display POST Diagnostic Screen.
Boot Menu	Enabled (Unchangeable)	Sets whether to display the boot drive selection window after POST.
NumLock	Auto (Unchangeable)	Sets the state of the NumLock key when booting the server.

7.2.4 Advanced Menu

Use this menu to set the peripheral devices and PCI device options.

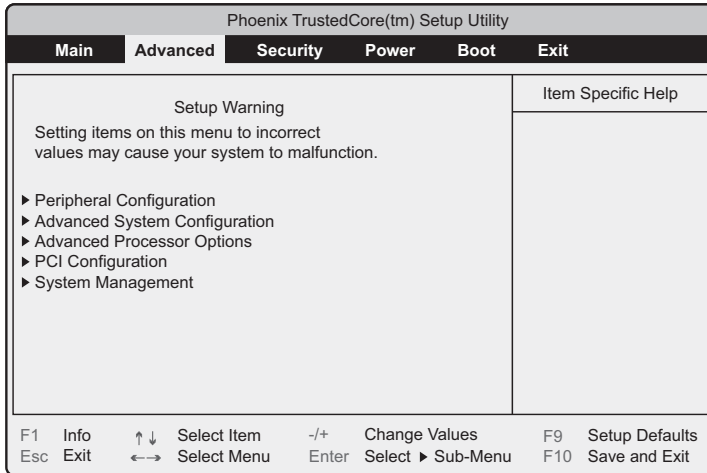

table: Items on the Advanced menu

Item	Description
Peripheral Configuration	Configures the serial port, parallel port, etc. Press the [Enter] key to display the "7.2.5 Peripheral Configuration Submenu" (→pg.133) screen.
Advanced System Configuration	Configures additional settings. Press the [Enter] key to display the "7.2.6 Advanced System Configuration Submenu" (→pg.134) screen.
Advanced Processor Options	Configures processor settings. Press the [Enter] key to display the "7.2.7 Advanced Processor Options Submenu" (→pg.135) screen.
PCI Configuration	Configures the PCI device. Press the [Enter] key to display the "7.2.8 PCI Configuration Submenu" (→pg.136) screen.
System Management	Displays the server hardware statuses. Pressing the [Enter] key displays "7.2.9 System Management Submenu" (→pg.137) screen.

7.2.5 Peripheral Configuration Submenu

Use this submenu to set the serial port, parallel port, etc.

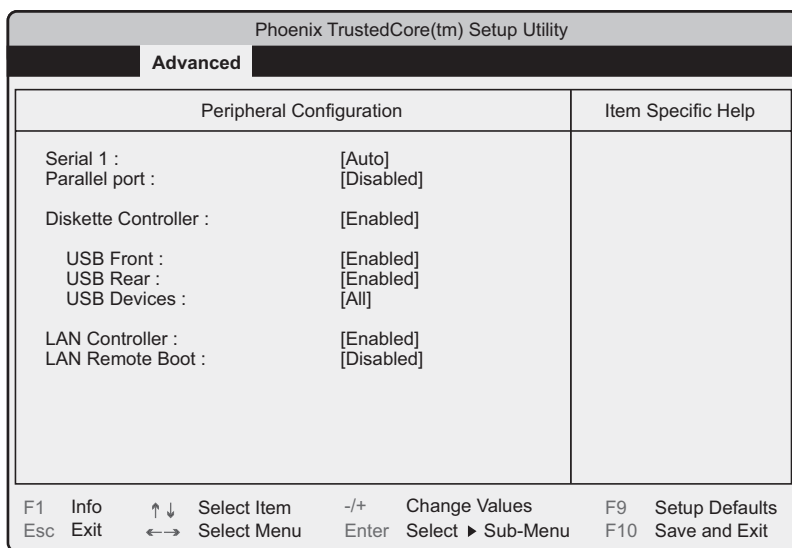

table: Items on the Peripheral Configuration submenu

Item	Setting	Description
Serial 1	<ul style="list-style-type: none"> • Disabled • Enabled • Auto (Initial value) 	Sets whether to enable or disable the serial port. Setting [Enabled] displays [Serial 1 Address].
Serial 1 Address	3F8h (Unchangeable)	Appears when [Serial 1] is [Enabled].
Parallel Port	<ul style="list-style-type: none"> • Disabled (Initial value) • Enabled • Auto 	Sets whether to enable or disable the parallel port.
Mode	<ul style="list-style-type: none"> • Printer • Bidirection (Initial value) • EPP • ECP 	Sets mode of the parallel port. When [Parallel Port] is [Auto] or [Enabled], this item appears and can be set.
Parallel Address	378h, IRQ7 (Unchangeable)	Appears when [Parallel Port] is [Enabled].
Diskette Controller	Enabled (Unchangeable)	Sets the floppy disk controller.
USB Front	<ul style="list-style-type: none"> • Disabled • Enabled (Initial value) 	Sets whether to use the USB port on the front side.
USB Rear	<ul style="list-style-type: none"> • Disabled • Enabled (Initial value) 	Sets whether to use the USB port on the rear side.
USB Devices	All (Unchangeable)	Sets whether to enable or disable USB devices.
LAN Controller	Enabled (Unchangeable)	Sets whether to enable or disable the onboard LAN controller.
LAN Remote Boot	<ul style="list-style-type: none"> • Disabled (Initial value) • Enabled 	Sets whether to perform a network boot. This function allows booting the server via the network. It is used for remote installation of the OS, etc. This item can be set only when [LAN Controller] is [Enabled].

7.2.6 Advanced System Configuration Submenu

Use this submenu to configure the onboard system settings.

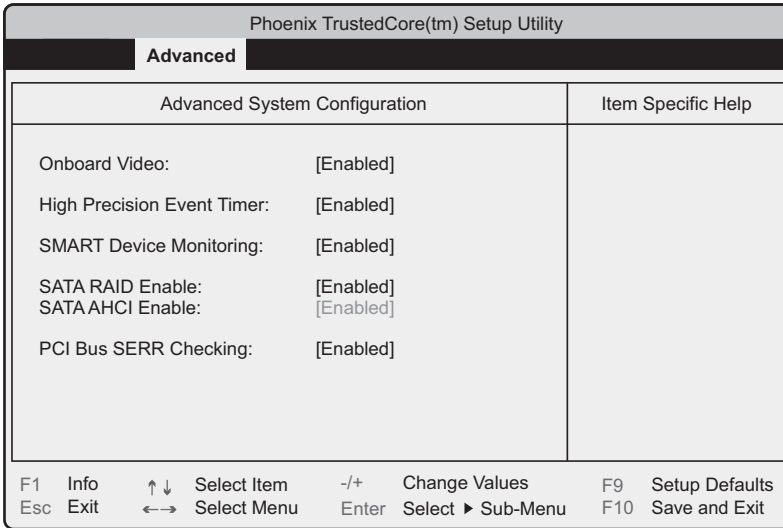

table: Items on the Advanced System Configuration submenu

Item	Setting	Description
Onboard Video	Enabled (Unchangeable)	Sets whether to enable or disable the display function on the baseboard.
High Precision Event Timer	<ul style="list-style-type: none"> • Disabled • Enabled (Initial value) 	Sets whether to use the high precision timer of the chipset.
SMART Device Monitoring	Enabled (Unchangeable)	Sets whether to monitor SMART device.
SATA RAID Enable	<ul style="list-style-type: none"> • Disabled • Enabled 	Sets whether to enable or disable the SATA RAID function. The initial values differ depending on the type of the server. For the system without an array configuration or the system with an SAS array controller card installed, set this item to [Disabled].
SATA AHCI Enable	<ul style="list-style-type: none"> • Disabled • Enabled 	Sets whether to enable or disable AHCI mode. This item must be the same setting as [SATA RAID Enable].
PCI Bus SERR Checking	Enabled (Unchangeable)	Sets whether to detect the PCI Bus error (system error).

7.2.7 Advanced Processor Options Submenu

Use this submenu to configure the processor settings.

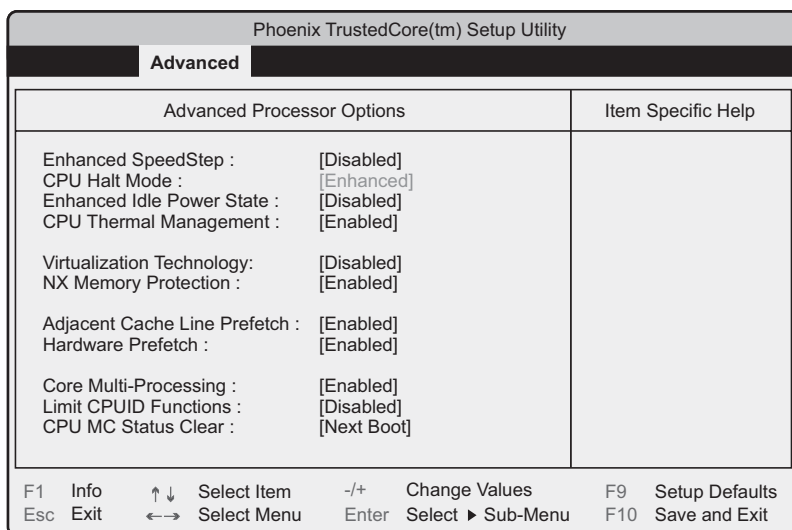

table: Items on the Advanced Processor Options submenu

Item	Setting	Description
Enhanced SpeedStep	<ul style="list-style-type: none"> Disabled (Initial value) Enabled 	Sets whether to enable or disable the power saving function. This item does not appear depending on CPU.
CPU Halt Mode	Enhanced (Unchangeable)	Configures the CPU internal setting.
Enhanced Idle Power State	Disabled (Unchangeable)	Configures the CPU internal setting. This item does not appear depending on CPU.
CPU Thermal Management	Enhanced (Unchangeable)	Configures the CPU internal settings.
Virtualization Technology	<ul style="list-style-type: none"> Disabled (Initial value) Enabled 	Sets whether to enable or disable Virtualization Technology. This item does not appear depending on CPU.
NX Memory Protection	<ul style="list-style-type: none"> Disabled (Initial value) Enabled 	Sets whether to enable or disable "execute disable bit function" of processor.
Adjacent Cache Line Prefetch	Enabled (Unchangeable)	Configures the CPU internal settings.
Hardware Prefetch	Enabled (Unchangeable)	
Core Multi-Processing	Enabled (Unchangeable)	Sets whether to enable or disable multi-core function. This item does not appear depending on CPU.
Limit CPUID Functions	Disabled (Unchangeable)	Sets whether to limit CPUID expanded function. If the OS does not support expanded functions, the system may not start.
CPU MC Status Clear	Next Boot (Unchangeable)	Configures the CPU internal settings.

7.2.8 PCI Configuration Submenu

Use this submenu to set the PCI device.

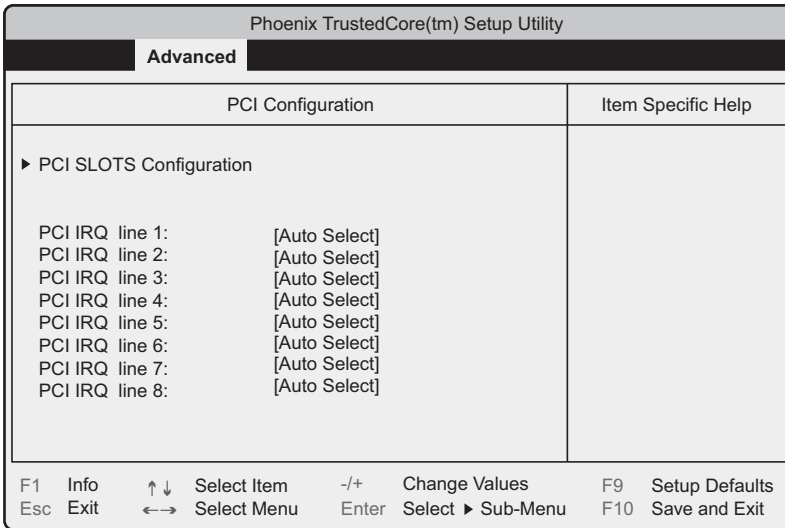

table: Items on the PCI Configuration submenu

Item	Setting	Description
PCI SLOTS Configuration		Configures the PCI slots. Press the [Enter] key to display the [PCI SLOTS Configuration] submenu screen.
PCI Slot 1 Configuration		Sets whether to initialize the expansion ROM on each PCI slot.
Option ROM SCAN	Disabled (Unchangeable)	
PCI Slot 2 Configuration		
Option ROM SCAN	Disabled (Unchangeable)	
PCI Slot 3 Configuration		Sets the PCI IRQ.
Option ROM SCAN	Enabled (Unchangeable)	
PCI Slot 4 Configuration		
Option ROM SCAN	Disabled (Unchangeable)	
PCI IRQ Line 1-8	Auto Select (Unchangeable)	

7.2.9 System Management Submenu

This submenu displays the statuses of the battery, the fans and the temperature sensors.

Phoenix TrustedCore(tm) Setup Utility			
Advanced			
System Management		Item Specific Help	
Battery State	OK		
SM Fan Control	[Auto]		
Fan State :			
Power Supply :	OK		
Fan 1 :	None		
Fan 2 :	OK		
Fan 3 :	OK		
Thermal Sensor State :			
CPU :	OK		
Inside :	OK		
System :	OK		
Hard Disk :	OK		
F1 Info	↑↓ Select Item		-/+ Change Values
Esc Exit	←→ Select Menu		Enter Select ▶ Sub-Menu
			F9 Setup Defaults
		F10 Save and Exit	

table: Items on the System Management submenu

Item	Setting	Description
Battery State		Displays the status of the battery.
SM Fan Control	Auto (Unchangeable)	Sets a control method for the system fans.
Fan State		Displays the statuses of the fans.
Power Supply		Displays the status of the power supply fan.
Fan 1		Displays the status of Fan 1 (not installed).
Fan 2		Displays the status of Fan 2 (on the server front).
Fan 3		Displays the status of Fan 3 (on the server rear).
Thermal Sensor State		Displays the status of the temperature sensor.
CPU		Displays the status of the CPU temperature sensor.
Inside		Displays the status of the server inside temperature sensor.
System		Displays the status of the system temperature sensor.
Hard Disk		Displays the status of the hard disk unit temperature sensor.

7.2.10 Security Menu

Use this menu to set the security options.

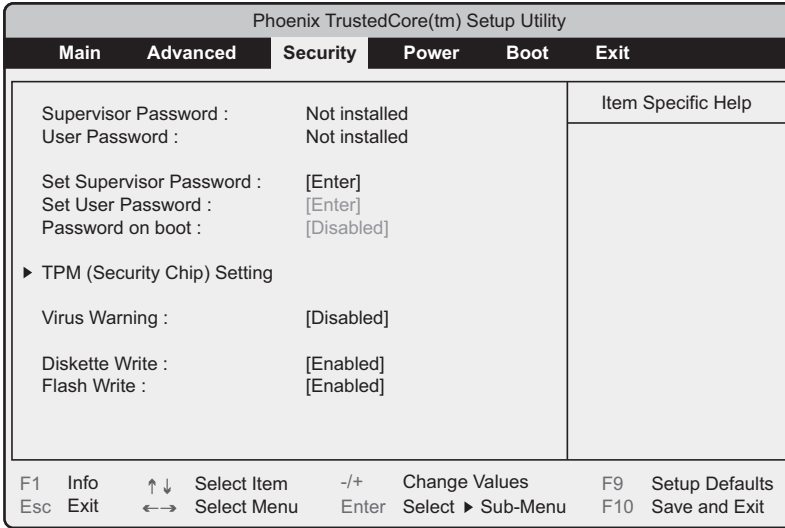

table: Items on the Security menu

Item	Setting	Description
Supervisor Password		Displays whether the password (supervisor password), which is used for setup, has been set. <ul style="list-style-type: none"> • Not Installed: A password is not set yet. • Installed: A password is already set.
User Password		Displays whether the password (user password), which is used to access to the server, has been set. <ul style="list-style-type: none"> • Not Installed: A password is not set yet. • Installed: A password is already set.
Set Supervisor Password		Sets the password (supervisor password) which is used for security of BIOS setup. Once the password is set, password entry is required when BIOS Setup Utility starts up. Press the [Enter] key to display the password entry window. Enter the supervisor password. For details, refer to "8.4.2 Security against Unauthorized Use" (→pg.161).
Setup Password Lock	<ul style="list-style-type: none"> • Standard (Initial value) • Extended 	Sets a scope of protection with the supervisor password. [Supervisor Password] must be set to set this item.
Set User Password		Sets the user password. Once the password is set, password entry is required to access to the server. This password can be set when [Supervisor Password] has been set. Press the [Enter] key to display the password entry window. Enter the user password. For details, refer to "8.4.2 Security against Unauthorized Use" (→pg.161).
User Password Mode	Standard (Unchangeable)	Sets how way to enter a password on the system startup.
Password on boot	<ul style="list-style-type: none"> • Disabled (Initial value) • Enabled 	Sets whether to enable or disable to enter the password when the system starts up.

table: Items on the Security menu

Item	Setting	Description
System Password Lock	<ul style="list-style-type: none"> • Standard (Initial value) • WOL SKIP 	Sets whether to enter a password when turning on the server by Wakeup On LAN.
TPM (Security Chip) Setting	Pressing the [Enter] key displays [TPM (Security Chip) Setting] submenu.	
Security Chip	Disabled (Unchangeable)	Sets whether to enable the security chip.
Virus Warning	Disabled (Unchangeable)	Sets whether to check the boot sector of the hard disk drive on and after the previous system startup. If the boot sector is changed without a clear reason, it is necessary to scan the system for computer viruses with a virus detection program.
Diskette Write	Enabled (Unchangeable)	Sets whether to allow writing on a floppy disk.
Flash Write	Enabled (Unchangeable)	Sets whether to allow writing on the BIOS Flash ROM.

7.2.11 Power Menu

Use this menu to configure power on/off settings.

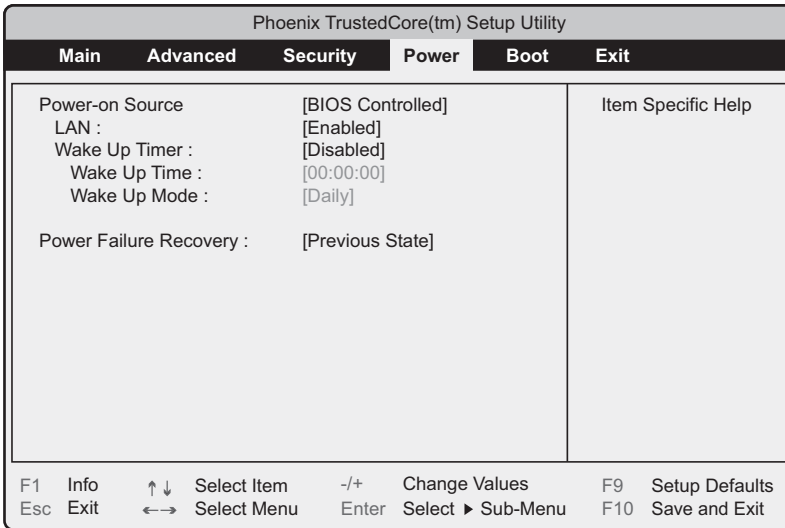
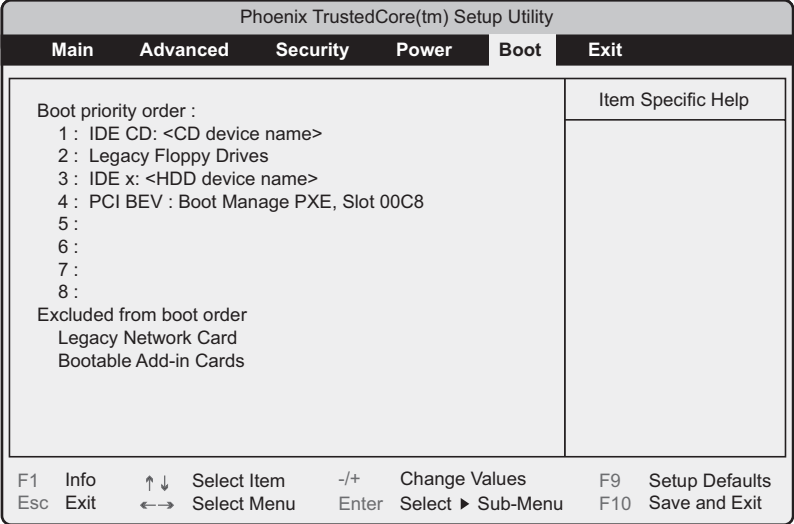

table: Items on the Power menu

Item	Setting	Description
Power-on Source	BIOS Controlled (Unchangeable)	Configures the power-on setting.
LAN	<ul style="list-style-type: none"> Disabled Enabled (Initial value) 	Sets whether to enable or disable the server to be turned on via LAN.
Wake Up Timer	Disabled (Unchangeable)	Sets whether the power is turned on at a certain time or after a certain time has passed. A separate program is required to set the startup time. Set the following items when setting [Enabled].
Wake Up Time	[00:00:00]	Sets the startup time when using [Wake Up Timer].
Wake Up Mode	Daily (Unchangeable)	Sets the startup mode when using [Wake Up Timer].
Wake Up Day	1 (Unchangeable)	Sets this item when [Monthly] in [Wake Up Mode] has been set.
Power Failure Recovery	<ul style="list-style-type: none"> Always On Always Off Previous State (Initial value) Disabled 	Sets a power state for when the electricity is supplied again after power-off due to such an event as power outage. Note: ▶ For UPS scheduled operation, set this item to [Always On]. Otherwise, the server may not be turned on at the specified time.

7.2.12 Boot Menu

Use this menu to set the priority order of startup. The names of CD devices and HDD devices on the display vary depending on the installed devices.



7.2.13 Exit Menu

Use this menu to exit BIOS Setup Utility.

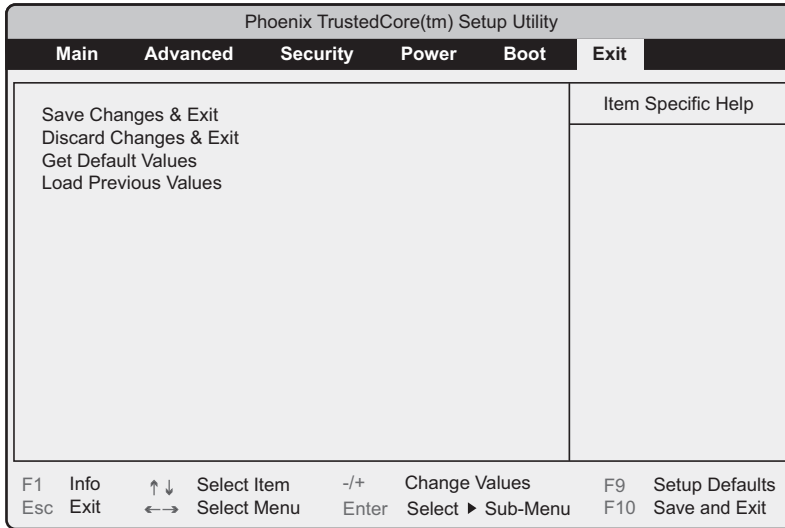

table: Items on the Exit menu

Item	Description
Save Changes & Exit	Saves the current settings and exit BIOS Setup Utility. After it exits, the server reboots.
Discard Changes & Exit	Exits BIOS Setup Utility without saving current settings. Previously saved settings remain valid.
Get Default Values	Returns all items to the default values of the server.
Load Previous Values	Sets all items to the values before the last changes by reading from CMOS. Current setting values are discarded.

IMPORTANT

- ▶ Note the following points to return the configured values to the default values by [Get Default Values].
 - When an Onboard Software RAID is not used, confirm that [SATA RAID Enable] and [SATA AHCI Enable] are [Disabled] on the [Advanced System Configurations] submenu of the [Advanced] menu. If not, the system may not start up.
 - When an Onboard Software RAID is used, confirm that the startup priority has been set properly on the [Boot] menu. When the priority of CD/DVD drive is low, startup from the CD/DVD drive may fail.

Chapter 8

Operation and Maintenance

8

This chapter explains the operations that become necessary after starting to use this server as well as daily care and maintenance.

8.1 Daily Maintenance	144
8.2 Troubleshooting	148
8.3 System Event Log	160
8.4 Security	161
8.5 Backup	164
8.6 Restoring the System	167
8.7 Reinstalling the OS	169
8.8 Maintenance Service	170

8.1 Daily Maintenance

This section explains procedures for checking the status of the server in operation and for performing daily maintenance.

● Information for PRIMERGY

For the latest information on PRIMERGY, update modules, drivers and the software, refer to the Fujitsu PRIMERGY website.

<http://www.fujitsu.com/global/services/computing/server/ia/driver/>

Regarding BIOS and firmware, contact to Fujitsu Support Office. Refer to the website below.

http://www.fujitsu.com/global/contact/computing/PRMRGY_index.html

8.1.1 Checking the Server Status

■ Checking each LED

This server is equipped with LEDs that display various hardware conditions.

Check the server status with each LED after starting the server. For locations and functions of each status LED, refer to "1.3 Component Names and Functions" (→pg.21).

■ Server Monitoring Tool (ServerView)

ServerView is software to monitor whether the server hardware is in a normal state to protect important server resources. When using ServerView, the server hardware is monitored all the time. If an error that could cause trouble is detected, the error is notified in real-time which enables early detection. This allows quicker response to system errors and prevents the error from becoming a serious problem.

For an overview and installation of ServerView and other high reliability tools, refer to "1.2.2 High Reliability Tools" (→pg.18) and "Chapter 5 High Reliability Tools" (→pg.93).

8.1.2 Cleaning

Perform periodical cleaning for the server.



WARNING



Electric Shock • Before cleaning, turn off the server and unplug the power cables from the outlets. Also turn off peripherals and disconnect them from the server. Otherwise electric shock may occur. (→"1.4.2 Turning Off the Server" (pg.29)).



• Do not use any cleaning sprays (including inflammable types). It may cause a device failure or a fire.

■ Cleaning the server

Wipe with a soft, dry cloth. For difficult stains, wipe with a cloth lightly dampened with a mild detergent. Once the stain has been removed, wipe off any remaining detergent with a cloth dampened with water. When wiping the server, be sure that no liquid enters the server. Do not use solvents. Use mild detergents only. Otherwise, the server may be damaged.

Vacuum the server periodically to prevent dust accumulation in ventilation holes.

POINT

- ▶ In dusty environments, dust accumulates up on the front and rear panels of the server over short periods. Install the server in a different location to avoid failures.

■ Cleaning the server interior

In dusty environments, dust accumulates inside of the server. Dust deposits may cause a server failure, fire, or electric shock. To keep the PRIMERGY server in good condition, vacuum the interior of the server periodically to remove dust deposits.

POINT

Cleaning components

- ▶ CPU: Dust deposits must be removed, otherwise it will impair the cooling performance.
- ▶ Fan: Remove dust from and around the fan.
- ▶ Memory / Expansion cards: Remove dust between memory modules and between expansion cards. Remove dust from the connector before adding a memory module or an expansion card.
- ▶ Internal hard disk units / 5-inch internal devices: Remove dust deposits from units and devices. Tape devices are particularly susceptible to dust and may cause failures. Install them in a clean environment.



WARNING



Electric Shock • Do not disassemble the PSU when cleaning the server interior. Doing so can cause failures or electric shock.

IMPORTANT

- ▶ Be careful when removing components such as CPU, memory modules, or hard disk units. Be sure to install parts and cables in the original position.
- ▶ Leaving dust on the server can cause failure. Be sure to remove any dust from the server.

■ Cleaning the keyboard

Wipe with a soft, dry cloth.

■ Cleaning the mouse

Wipe the surface with a soft, dry cloth. If the tracking ball does not move smoothly, remove the ball and clean it.

● **Cleaning procedure**

- 1** Remove the cover from the base of the mouse.
Remove the cover by rotating it in the direction of the arrow.

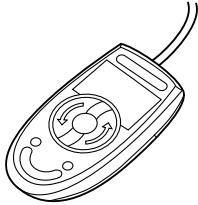

- 2** Remove the ball and rinse it with water.
Flip the mouse over to remove the ball. Afterwards, wash it with water.

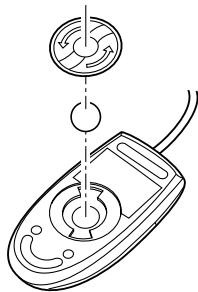

- 3** Clean the inside of the mouse.
Wipe the inside of the mouse, the roller, and the bottom cover with a damp cloth.
- 4** Insert the ball and apply the cover.
After the ball and inside of the mouse are dry, put back the ball and the cover.

■ **Cleaning the floppy disk drive**

Long-term use of the floppy disk drive attributes to accumulation of dust on the device head (the part which reads/writes data). A dirty head can impair the ability to read/write data to/from a floppy disk correctly. Clean the head once every three months.

● **Cleaning procedure**

- 1** Insert the cleaning disk into the floppy disk drive.
- 2** Access the floppy disk drive from the OS.
 - For Windows, access it with Explorer.
 - For Linux, execute the "mount" or "dd" commands of the floppy disk drive.The process is completed when an error message such as to indicate that the disk cannot be read is displayed.
- 3** Remove the cleaning disk from the floppy disk drive.

■ **Optional devices**

For details about cleaning optional devices, refer to the manual for each optional device.

8.2 Troubleshooting

This section explains the resolutions when the server is not running properly or when error messages are displayed. For each situation, refer to the following.

- Hardware problems: "8.2.1 Hardware Troubleshooting" (→pg.148)
- Error messages: "8.2.2 Error Messages" (→pg.150)
- Software problems: "8.2.3 Software Troubleshooting" (→pg.155)

If the problem is not resolved after performing troubleshooting, contact an office listed in the "Contact Information" of "Start Guide".

When contacting your maintenance engineer, refer to "8.8.1 Contacting Maintenance Support" (→pg.170) and collect the required information.

● Information for PRIMERGY

For the latest information on PRIMERGY, update modules, drivers and the software, refer to the Fujitsu PRIMERGY website.

<http://www.fujitsu.com/global/services/computing/server/ia/driver/>

Regarding BIOS and firmware, contact to Fujitsu Support Office. Refer to the website below.

http://www.fujitsu.com/global/contact/computing/PRMRGY_index.html

8.2.1 Hardware Troubleshooting

This section explains hardware related troubleshooting. Check the following if the server does not operate properly or a failure is suspected. For optional devices, refer to the manual for each optional device.

■ Server

● The server does not power on, or the power LED on the front of the server does not light up.

Check to see whether the power cable is properly connected to the outlet. For instructions on connecting the power cable, refer to "Start Guide".

● The hard disk access LED does not light up.

The server may be damaged. Contact an office listed in the "Contact Information" of "Start Guide". When contacting your maintenance engineer, refer to "8.8.1 Contacting Maintenance Support" (→pg.170) and obtain the required information.

● An error message is displayed.

Handle the error message by referring to "8.2.2 Error Messages" (→pg.150).

■ Display

● The display does not power on.

Check to see whether the power cable of the display is properly connected to the outlet. For details, refer to "Start Guide" and the manual of the display.

● The screen is distorted at Linux shutdown.

Although the screen display may be distorted when shutting down the system in the Linux environment, the system is shut down successfully. This has no effect on the system.

● Nothing is displayed on the screen.

- Check to see whether the display cable is connected properly. If it is not connected, turn the server off and then connect the cable. For the connection location, refer to "Start Guide".
- Check that the brightness volume and contrast volume of the display are adjusted correctly. If they need to be adjusted, perform the necessary adjustments.
For details, refer to the manual of the display.
- There may be an error in the system area of the memory. Contact an office listed in the "Contact Information" of "Start Guide".

● Typing on the keyboard does not display any characters, or the mouse cursor does not move.

Check to see whether the keyboard and mouse are connected properly. If not connected, turn the server off and then connect the cables to the server. For the connection location, refer to "Start Guide".

● The screen shakes.

If a device that produces a strong magnetic field such as a television or speaker is near the display, place them further away from the display.

The display may also shake if a nearby cell-phone receives a call. Do not use a cell-phone near the display.

■ Floppy disk drive

● Cannot read or write to the floppy disk.

The device head may be dirty. Clean the drive using a cleaning floppy disk. For cleaning methods, refer to "8.1.2 Cleaning" (→pg.144).

● Cannot write to the floppy disk.

The write protection of the floppy disk may be applied. Flip the switch on the disk to allow writing.

■ CD/DVD drive unit

● Cannot read data.

- Check to see whether the CD/DVD is inserted properly. If not, insert the CD/DVD properly with the label facing up.
- Check to see whether the CD/DVD is not dirty. If it is dirty, wipe it with a soft, dry cloth.
- Check to see whether the CD/DVD is scratched or warped. If scratched or damaged, do not use such a CD/DVD.

● The DVD-ROM unit does not operate properly.

Check to see whether the internal cable is connected properly. If not connected, correctly connect the internal cable.

8.2.2 Error Messages

■ POST error messages

This section explains error messages of Power On Self Test: a device check performed during the server startup (POST).

If an error occurs during POST, the following messages are displayed.

POINT

- ▶ To check/change the settings of BIOS Setup Utility, refer to "7.2 BIOS Setup Utility" (→pg.127).
- ▶ For instructions on checking peripheral connections, refer to "Start Guide".
- ▶ For details on installing internal options, refer to "Chapter 6 Installing Internal Options" (→pg.99).

table: List of POST error messages

Message	Description
Failure Fixed Disk	Indicates a SATA device error. Check whether the SATA device is properly installed. If the message still appears, the SATA device must be replaced. Contact an office listed in the "Contact Information" of "Start Guide".
Stuck Key	Indicates a keyboard error. Check whether any key on the keyboard is being pressed, or the keyboard is properly connected. If the message still appears, the keyboard must be replaced.
Keyboard error	
Keyboard controller error	Indicates a keyboard controller error. Check whether any key on the keyboard is being pressed. If the message still appears, the baseboard must be replaced. Contact an office listed in the "Contact Information" of "Start Guide".
System RAM Failed at offset: *****h	Indicates a memory error. Turn off the server and turn it back on. If the message still appears, check the error log and replace the faulty memory module. If the message still appears, the baseboard must be replaced. Contact an office listed in the "Contact Information" of "Start Guide".
Shadow RAM Failed at offset: *****h	
Extended RAM Failed at address line: ****h	

table: List of POST error messages

Message	Description
Memory type mixing detected	The installation configuration of the memory is not acceptable. Check that the same type of memory modules is installed in the slots of the same bank. If the message displays even though the installation is adequate, replace the memory module. Even when the message still appears after replacement, the baseboard must be replaced. Contact an office listed in the "Contact Information" of "Start Guide".
Single-bit ECC error occurred	Indicates a memory error. Check the error logs. If the error frequency reaches the replacement level (twice per hour), the memory module must be replaced.
Multiple-bit ECC error occurred	Indicates a memory error. Check the error logs and replace the faulty memory module. If the message still appears after the replacement, the baseboard must be replaced. Contact an office listed in the "Contact Information" of "Start Guide".
Memory decreases in Size	Indicates a memory error. Due to a memory failure, available memory capacity is less than the capacity of the actually installed memory. Check the error log and replace the faulty memory module. If the message still appears after the replacement, the baseboard must be replaced. Contact an office listed in the "Contact Information" of "Start Guide".
Non Fujitsu Siemens Memory Module detected - Warranty restricted!	Indicates a memory error. Check whether the settings of BIOS Setup Utility are correct. If the message still appears, the baseboard must be replaced. Contact an office listed in the "Contact Information" of "Start Guide".
System battery is dead - Replace and run SETUP	Indicates a battery error. Check whether the battery on the baseboard is properly set. If the message still appears, the baseboard must be replaced. Contact an office listed in the "Contact Information" of "Start Guide".
System CMOS checksum bad - Default configuration used	Indicates an error of the CMOS settings. Correct the current settings with BIOS Setup Utility or restore the settings to the initial values. If the message still appears, the baseboard must be replaced. Contact an office listed in the "Contact Information" of "Start Guide".
Password checksum bad? Password cleared	Indicates an error of the CMOS settings. Check the error logs. If a battery error occurs, the battery must be replaced. Contact an office listed in the "Contact Information" of "Start Guide".
System timer error	Indicates a system clock error. Turn off the server and turn it back on. If the message still appears, the baseboard must be replaced. Contact an office listed in the "Contact Information" of "Start Guide".
Real time clock error	Indicates a Real Time Clock (RTC) error. Start up BIOS Setup Utility and enter the present time and date on the [Main] menu. If the message still appears, the baseboard must be replaced. Contact an office listed in the "Contact Information" of "Start Guide".
Check date and time settings	Indicates an error of the date and time settings. Start up BIOS Setup Utility and enter the present time and date on the [Main] menu. If the message still appears, the baseboard must be replaced. Contact an office listed in the "Contact Information" of "Start Guide".

table: List of POST error messages

Message	Description
Previous boot incomplete - Default configuration used	POST is not complete during the last startup. Be sure to perform the following operation. Otherwise, the failure of OS startup or server operation may occur. <ol style="list-style-type: none"> 1. Start up BIOS Setup Utility. 2. Select the [Exit] menu – [Save Changes & Exit], and press the [Enter] key. The message "Save configuration changes and exit now?" is displayed. 3. Select [Yes] and press the [Enter] key. BIOS Setup Utility exits and the server restarts.
CPU had been changed	The CPU has been changed. Check whether the CPU is properly installed. If the installation of CPU is appropriate and the message still appears, the CPU or the baseboard must be replaced. Contact an office listed in the "Contact Information" of "Start Guide".
CPU mismatch detected	The CPU frequency has changed. Check whether the supported CPU is installed. If the compatible CPU is appropriate and the message still appears, update BIOS by using the BIOS update tool, provided with the CPU. If the message still appears, the CPU or the baseboard must be replaced. Contact an office listed in the "Contact Information" of "Start Guide".
Available CPUs do not support the same bus frequency- System halted!	
Diskette drive A error	Indicates a floppy disk drive error. Check whether the floppy disk drive cable is connected properly. Also check the setting of [Diskette A] on the [Main] menu of BIOS Setup Utility. If both the connecting environment and the setting value are correct and the message still appears, the floppy disk drive, the cables or the baseboard must be replaced. Contact an office listed in the "Contact Information" of "Start Guide".
Incorrect Drive A type - run SETUP	
System cache error - Cache disabled	Indicates a system cache error. Turn off the server and turn it back on. If the message still appears, check the error log and replace the CPU if it is faulty. If the CPU is considered as keeping its capability, the baseboard must be replaced. Contact an office listed in the "Contact Information" of "Start Guide".
System Memory Exceeds the CPU's caching limit	Indicates a system cache error. The CPU must be replaced. Contact an office listed in the "Contact Information" of "Start Guide".
DMA Test Failed	Indicates a DMA test error. Turn off the server and turn the server back on. If the message still appears, the baseboard must be replaced. Contact an office listed in the "Contact Information" of "Start Guide".
Software NMI Failed	Indicates an NM processing error. Verification is required by checking the error logs before and after the error. Contact an office listed in the "Contact Information" of "Start Guide".
Fail-safe Timer NMI Failed	
The system performed an emergency shutdown	The system shutdown is executed. Check the error logs before and after the error.
Verify CPU Frequency selection in Setup	Indicates a CPU error. Turn off the server and turn it back on. If the message still appears, check the error log and replace the CPU if faulty. If the message still appears, the baseboard must be replaced. Contact an office listed in the "Contact Information" of "Start Guide".

table: List of POST error messages

Message	Description
Correctable memory error in module n	Indicates a memory error. Check the error logs. If the error frequency reaches the replacement level (twice per hour), the memory module must be replaced.
Uncorrectable memory error in module n	Indicates a memory error. Check the error log and replace the appropriate memory module. If the message still appears, the baseboard must be replaced. Contact an office listed in the "Contact Information" of "Start Guide".
System monitoring: Configuration change	Indicates an error of the hardware configuration. Verification is required by checking the error logs before and after the error. Contact an office listed in the "Contact Information" of "Start Guide".
System monitoring: Battery voltage out of range	Indicates a battery error. Replace the button battery. If the message still appears, the baseboard must be replaced. Contact an office listed in the "Contact Information" of "Start Guide".
System monitoring: Supply voltage out of range	Indicates a power supply error. The power supply unit must be replaced. Contact an office listed in the "Contact Information" of "Start Guide".
System monitoring: Fan failed	Indicates a fan error. Verification is required by checking the error logs before and after the error. Contact an office listed in the "Contact Information" of "Start Guide".
System monitoring: sensor failed	Indicates a sensor error. Verification is required by checking the error logs before and after the error. Contact an office listed in the "Contact Information" of "Start Guide".
Memory configuration has changed - Run SETUP	Indicates a memory error. The memory size has changed since the last startup. Check the error log and replace the appropriate memory module. If the message still appears, the baseboard must be replaced. Contact an office listed in the "Contact Information" of "Start Guide".
No usable system memory.	Indicates a memory error. No memory available to the system are detected. Check the error log and replace the memory module. If the message still appears, contact an office listed in the "Contact Information" of "Start Guide".
Memory module disabled! This module is no longer available for the operating system.	Indicates a memory error. Turn off the server and check whether the memory module is installed correctly. If the message still appears, check the error log and replace the appropriate memory module. If the message still appears after the replacement, the baseboard must be replaced. Contact an office listed in the "Contact Information" of "Start Guide".
No usable CPU	Indicates an installed CPU error. Replace the CPU. If the message still appears, the baseboard must be replaced. Contact an office listed in the "Contact Information" of "Start Guide".
Patch for installed CPU not loaded. Please run the bios flash update diskette.	Check the correct CPU is installed. If the correct CPU is properly installed and the message still appears, the CPU or the baseboard must be replaced. Contact an office listed in the "Contact Information" of "Start Guide".
CPU disable! CPU is no longer available for the operating system.	Indicates a CPU error. No CPUs available to the system are detected. Check the error log and replace the CPU. If the message still appears, the baseboard must be replaced. Contact an office listed in the "Contact Information" of "Start Guide".

■ Server Management Tools error messages

The following error messages may appear while executing Server Management Tools. In such cases, perform the appropriate resolutions. If messages other than the following are displayed, contact an office listed in the "Contact Information" of "Start Guide".

table: List of Server Management Tools error messages

Message	Description
Write protect error writing drive A. Abort, Retry, Fail?	The inserted floppy disk is write-protected. Disable the write-protect, and then press the [R] key.
Not ready writing drive A. Abort, Retry, Fail?	The floppy disk is not inserted into the floppy disk drive. Insert the proper floppy disk ("Server Management Tools" disk), and then press the [R] key.
ERROR: Fail to create data file.	The following factors may be possibly root causes. Check the floppy disk condition again. <ul style="list-style-type: none"> • The floppy disk is write-protected. Disable the write-protect and retry. • The floppy disk is not inserted into the floppy disk drive. Insert the proper floppy disk, and then retry. • The floppy disk contains improper data. Create "Server Management Tools" disk again. If this occurs while recovering the BIOS information, configure the information using BIOS Setup Utility. Then store the BIOS information.
ERROR: Fail to write 1st CMOS data into data file. nn	
ERROR: Fail to write 2nd CMOS data into data file. nn	
ERROR: Fail to write ESCD data into the data file. nn	
ERROR: Fail to write SEEPROM data into the data file. nn	The file to recover the BIOS information does not exist on this floppy disk. Insert the floppy disk on which the BIOS information was stored, and then retry.
ERROR: Fail to open data file.	
ERROR: Fail to write 1st CMOS data into system. nn	
ERROR: Fail to write 2nd CMOS data into system file. nn	
ERROR: Fail to write ESCD data into system file. nn	The following factors may be possibly root causes. Check the floppy disk condition again. <ul style="list-style-type: none"> • The floppy disk is not inserted into the floppy disk drive. Insert the proper floppy disk, and then retry. • A different model or an unsupported version of the BIOS information. Insert the proper floppy disk, and then retry. • The floppy disk contains improper data. Create "Server Management Tools" disk again. If this occurs while recovering the BIOS information, configure the information using BIOS Setup Utility. Then store the BIOS information.
ERROR: Fail to write SEEPROM data into system. nn	
Other messages	Contact an office listed in the "Contact Information" of "Start Guide".

8.2.3 Software Troubleshooting

This section explains software-related troubleshooting. For troubles during OS installation or system operation, refer to the following contents.

■ Trouble at a ServerStart Startup

- **After a boot from PRIMERGY Startup Disc, nothing is displayed on the screen.**

This situation may occur if the hard disk drive still contains the previous information. In that case, this situation may occur even when you insert Windows Server 2003 Installation CD-ROM.

In such a situation, physically format the hard disk drive to delete the previous information and start up ServerStart.

For physical formatting for hard disk drive, refer to the manual on Array Controller Document & Tool CD.

■ Error messages during installation

The following error messages may appear during installation using ServerStart. Observe the corrective action against the relevant error.

- **"WzDiskAdmin: System Error!, Last Error: The device is not ready." appears**

Optional SCSI/SAS devices (e.g., hard disk cabinet, DAT unit) may be connected.

Disconnect the optional SCSI/SAS devices and perform installation again. Connect the optional devices after the installation completes.

- **"Operating System not found" appears when the system restarts from the CD/DVD after file copy**

The following factor may be possibly root cause.

- The Active flag is selected.

- **"Missing Operating System" appears during installation**

The installation partition size may be too large. Specify the installation partition size correctly. For details on the installation partition size, refer to "2.3.1 Installation Partition Size" (→pg.42).

- **"Error 1920. Service (PXE Services) failed to start" appears during preconfigured installation**

The system installed with the preconfigured settings (PXE server) may not be connected to the network. Check the LAN cable connection and click [Rerun].

■ Application software which uses tftp client function (tftp.exe) does not operate properly

For the system on which Windows Server 2003 is installed, since the tftp client function (tftp.exe) is not installed by default, and application software which uses the tftp client function (tftp.exe) does not operate properly. To use the tftp client function (tftp.exe), install "tftp.exe" from the OS installation disc according to the following procedures.

- 1** Insert the OS installation disc into the CD/DVD drive.
The OS installation disc must be any of Windows Server 2003 CD that has applied SP1, Windows Server 2003 x64 DVD or Windows Server 2003 R2 Disc 1 CD-ROM.
- 2** Start the Command Prompt and move to the i386 folder of the CD/DVD drive.
- 3** Execute the following command to extract "tftp.exe" in the "%Systemroot%\system32" folder.

```
[CD/DVD drive]:\i386>expand -r:tftp.exe TFTP.EX_ %Systemroot%\system32
```

- 4** Confirm that "tftp.exe" exists in the "%Systemroot%\System32" folder.

■ Error Window appears after installing or uninstalling ServerView (For Windows Server 2003)

For Windows Server 2003 with Service Pack 1 applied, the following message may appear on restarting after installing/uninstalling ServerView. The operation will run properly. Click [Close Message] to close the message.

```
In order to protect the computer, this program is terminated by
Windows. Name: SNMP Service
```

■ Error Window appears after LAN driver installation (For Windows Server 2003)

The following window may appear when the installation of the LAN driver to the [Ethernet controller] under [Other devices] starts.

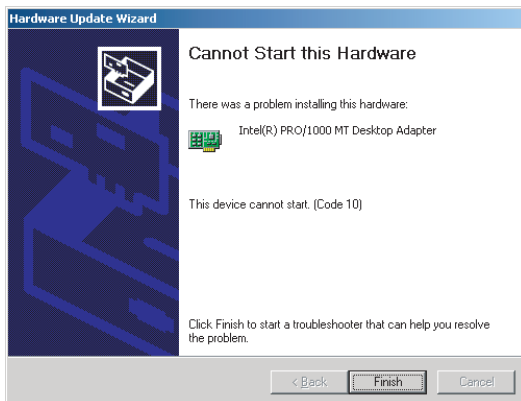

This error results from that the LAN driver for the network adapter recognized immediately after the OS installation is not updated.

Clicking [Finish] in this window displays the [Help and Support Center] window. Click [X] to close this window. The "!" mark is displayed at the LAN device name in Device Manager. The device names are displayed properly when all the LAN drivers are installed and the system is restarted.

■ LAN operation fails or error message appears during LAN driver installation

A conflict may have occurred between system resources including the LAN and other expansion cards. Delete all the LAN drivers and check that conflicts between system resources do not exist. Then, restart the system and reinstall the LAN drivers again.

■ Event log errors after installation

After installation, the following events may be displayed in Event Viewer. Check and perform the corrective action against the relevant event.

table: List of event log errors that may occur after installation

ID	Description	Cause and corrective action
62	This computer is a domain PDC at the root of forest. Use the net command "net time /setsntp:<server name>" to configure it for synchronization from an external time source.	<p>Cause: An NTP was selected as a component.</p> <p>Corrective action: ServerStart cannot configure the NTP server due to the absence of items for specifying it. After OS installation, perform the following procedure to specify the time server.</p> <ol style="list-style-type: none"> 1. Start SNTP server operation on another machine. For example, the SNTP server address is <172.22.78.246>. 2. Enter the following at a Command Prompt. net time /setsntp:172.22.78.246 w32tm -s 172.22.78.246
1000	The user or computer name cannot be identified. The return value is "1722".	<p>Cause: The primary DNS server address may be invalid or the server cannot be accessed.</p> <p>Corrective action: Perform the following procedures to correct the DNS address in Internet protocol (TCP/IP) properties.</p> <ol style="list-style-type: none"> 1. Right-click [My Network] and click [Properties]. 2. Right-click [Local Area Connection] and click [Properties]. 3. Click [Internet Protocol (TCP/IP)] and click [Properties]. 4. Enter the correct DNS address in the [Primary DNS server] box.

■ Cannot collect the memory dump

If the memory dump file cannot be created, perform the following procedures.

● Correcting the settings

If the memory dump cannot be collected, check the settings of the paging file and memory dump file. For setting procedures, refer to "4.1 Memory Dump/Paging File Setting" (→pg.70).

● **Collecting memory dump to other than the system drive**

If the memory dump is set to be collected to the system drive (C:\), change the settings so that the memory dump can be saved to a drive other than the system drive. For setting procedures, refer to "4.1 Memory Dump/Paging File Setting" (→pg.70). If only the system drive exists, or if there is no free space in any of the drives, perform one of the following:

- Adding a hard disk unit
- Replacing with a higher-capacity hard disk unit

● **Reducing the installed memory to collect the memory dump**

There must be enough free disk space that matches the size of the installed memory; therefore, reduce the installed memory to a collectable size. Check the memory dump settings when changing the installed memory size.

For setting procedures, refer to "4.1 Memory Dump/Paging File Setting" (→pg.70).

● **Changing the write type of the debugging information**

If the memory dump cannot be collected, select a write type of debugging information within the range of free space of the volume size. If the above does not provide a solution, try increasing the size of the hard disk or adding an additional hard disk unit.

■ **Restoring the system**

In the event where the system file, system configuration, or environment changes during startup are corrupted, use the repair information stored on the repair disk created at the installation to restore the system. For restoration procedures, refer to "8.6.1 For Windows Server 2003" (→pg.167).

■ **SNMP Service startup fails**

If the Simple Network Management Protocol (SNMP) is installed, but has not started, perform the following procedures to start the service.

- 1** Click [Start] – [Administrative Tools] – [Computer Management].
- 2** Select [Services] on the [Services and Applications] menu.
- 3** On the details, select [SNMP Service].
- 4** Select [Start] on the [Action] menu.

POINT

- ▶ To have the service automatically start each time the OS starts, double-click [SNMP Service] on the details, and select [Automatic] for the [Startup type] setting of the [SNMP Service Properties] window.

■ Time display in Linux OS environment

● Difference in time between the OS and the hardware clock

Since the software clock on OS is employed but not the hardware clock functioned in the server for time display in Linux environment, time lag may occur between the OS and the hardware clock.

When time precision is required on OS, it is recommended to use the NTP service to periodically correct the time displayed on the OS.

● Changing the time settings for the OS and hardware clock

In a Linux environment, the time displayed on the OS (the software clock value on the OS) is written to the hardware clock in the server when the OS is shut down.

- Procedure for prohibiting the time on the OS from being written to the hardware clock

When you do not want the time on the OS to be written to the hardware clock at an OS shutdown, comment the following line out in `/etc/rc0.d/S01halt`.

```
runcmd $"Syncing hardware clock to system time" /sbin/hwclock $CLOCKFLAGS
```

↓

```
#runcmd $"Syncing hardware clock to system time" /sbin/hwclock $CLOCKFLAGS
```

- Procedure for reflecting the hardware clock value to the time on the OS

To reflect the hardware clock value to the software clock value on the OS, run the following command.

```
>hwclock --hctosys
```

8.3 System Event Log

This section explains how to refer to and operate system event logs.

8.3.1 How to Refer to Event Logs

ServerView S2 is used for reference of system event logs. A summary of reference procedures is described below. For details such as how to start up ServerView, refer to the "ServerView User's Guide".

- 1** Start up ServerView S2.
- 2** Click the server to be referred from the ServerList.
- 3** Select [Configuration] – [Recovery] on the menu list on the left side.
The list of all the system event logs is displayed.

8.3.2 Deleting the System Event Log

Use "Server Management Tools" disk to delete the system event logs.

- 1** Insert "Server Management Tools" disk into the floppy disk drive.
- 2** After the DOS Prompt is displayed, enter the following command, and press the [Enter] key.

```
A:\SMT>bioslog -clear
```

- 3** Restart the system.

8.4 Security

This server provides security provisions in order to protect resources of both hardware and software against theft and such. Additional security functions, such as preventing unauthorized use, provided by BIOS Setup Utility are also available to help maintain a highly reliable data security system.

8.4.1 Hardware Security

This section describes security function of hardware.

■ Locking the side cover

This server has the holes for antitheft lock on the server rear and the side cover. Use these holes to prevent the server hardware such as hard disk units and 5-inch internal devices from theft.

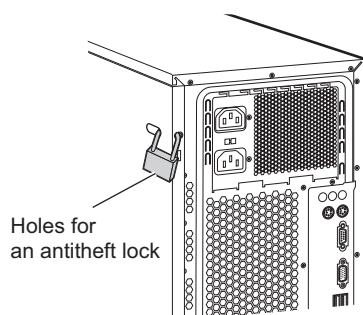

8.4.2 Security against Unauthorized Use

A password can be set to prevent unauthorized use of the server. Setting a password makes it necessary to enter the password in order to access the server. Without the password, the server cannot be used.

■ Password types

There are two types of passwords that define the privileges of server operations.

● User password (User password)

The password required to use the server. Unless the set password is entered, part of the BIOS setup cannot be accessed and the OS cannot be booted.

● Administrator password (Supervisor password)

This is the password that only allows the administrator to set up this server. Unless the set password is entered, the BIOS setup cannot be accessed and the OS cannot be booted.

■ Setting a password

The password is set in BIOS Setup Utility. For details on BIOS Setup Utility, refer to "7.2.10 Security Menu" (→pg.138).

1 Start up BIOS Setup Utility.

→"7.2.1 Starting and Exiting BIOS Setup Utility" (pg.127)

2 Select the [Security] menu and select the type of password to set.

- For the administrator password, select [Set Supervisor Password] and press the [Enter] key.
- For the user password, select [Set User Password] and press the [Enter] key.

3 When the password input window is displayed, enter the password to set.

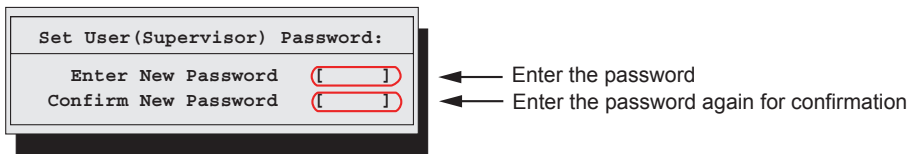

4 Enter the password again to confirm it.

5 Press the [Enter] key.

The password is set.

● Changing / Deleting passwords

If a password is already set, perform the above password setting operations to display the password change window.

- To change the password, perform the following settings and press the [Enter] key.

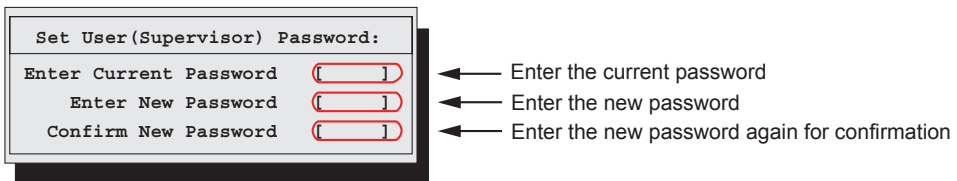

- To delete the password, enter the current password, and then press the [Enter] key without entering anything in the second and third fields. The status of "User (Supervisor) Password" changes to "Not installed".

POINT

- ▶ The system shuts down after three times password attempts. If this happens, turn off the server, turn it back on, and then enter the correct password.
- ▶ If you forgot your password and cannot start the server, change the jumper setting on the baseboard to reset the passwords. For jumper settings, refer to "7.1 Jumper Settings" (→pg.126).

8.4.3 Security When Disposing of the Server

■ Notes regarding the deletion of data from the hard disk when disposing of or transferring the server

When disposing of or transferring a server that has been used, the data in the hard disk may be read and used unscrupulously. To prevent confidential or important data from leaking out, the data on the hard disk must be wiped before disposal or transfer.

However, wiping the hard disk is not an easy task. Simply initializing (formatting) the hard disk or deleting the files may give the pretense that the data no longer exists, but in reality the data is simply no longer accessible to the OS, and it is still accessible to malicious individuals that can restore the data. Therefore, if confidential or important data is saved to the hard disk, in addition to the operations mentioned above, it is recommended to use third-party tools or services to wipe the data completely from the disk to prevent its restoration.

When disposing of or transferring the server, it is the customer's responsibility to wipe data contained in the hard disk in order to prevent such important data from leaking.

Also, if software license agreements prohibit unauthorized distribution of software (OS or application software), transferring the server without removing the software may violate the license agreements. These issues must be taken into consideration.

8.5 Backup

This server utilizes high reliability components and hard disks, however, as a further precautionary provision, it is recommended that periodic backups be taken of the data.

8.5.1 Importance of Backups

A backup of data stored on the server is required for data restoration in the event of server trouble resulting in a system failure or accidental data loss due to operational errors. If the data on the server is backed up, it can be restored from the backup in the event of hardware failures or data corruption in hard disks due to operational errors. If backups are not made, restoration is impossible and data will be permanently lost. To prepare for unexpected problems, be sure to perform periodic backups of the system.

8.5.2 Backup Devices, Software and Their Operations

Backup operations differ depending on network operating systems, applications, and system operations. Contact an office listed in the "Contact Information" of "Start Guide" and make backups using the following items.

- Backup device (e.g., DAT72 unit)
- Backup software
(Standard backup software supplied with the OS, e.g., ARCserve, Changer Option)
- Backup operations (schedules etc.)

Use our genuine backup devices and software. Observe the backup medium (tape etc.) storage conditions.

POINT

For mirroring and disk array systems

- ▶ To enhance system reliability, it is recommended to employ a mirroring or disk array system using an array controller together with periodical backup.

■ Notes on operating backups

Notes on operating backups are as follows. For details, refer to the device manuals and Readme.txt, included in the device driver.

● **Head cleaning**

Airborne dust and dust from the magnetic media can collect on the head of the magnetic tape device. To remove this dust, head cleaning must be implemented. Implement head cleaning when the device displays a cleaning request. Particularly DDS devices require periodic head cleaning, otherwise dust can cling to the magnetic head, creating a situation that cannot be cleaned with standard head cleaning methods, and eventually render the device useless. Also note that the cleaning media has a limit on how many times it can be used. Using cleaning media that exceeded its lifespan will have no cleaning effect. Note these points especially when performing automatic backups with library devices.

● **Managing media lifespan**

Media is a consumable product that must be replaced regularly. Continued use of media exceeding its lifespan can have negative effects on the device (e.g. increase the speed of dust accumulation). The lifespan of media varies depending on the environment and operation condition of the device, the type of backup software used, and other operation conditions, however, it is recommended that they be replaced sooner than later.

To manage the lifespan, write the use start date on the media.

● **Rotating media**

When using a single media cartridge repeatedly, backup data can be temporarily lost in the event the backup fails. Also if the hard disk fails during backup, the backup data cannot be recovered. Perform backup operations using multiple mediums on a rotating basis.

● **Avoid leaving media in devices**

Because the magnetic recording surface of the device is exposed, media can easily be affected by airborne dust when left inserted for a long period of time. Insert the media before using it, and remove the media after use, and restore it in its case. Also note that some tape devices write management information to the tape when ejecting the media. If the power were to go out when the media is still in the device, this writing process will not be performed and the media may become corrupted.

To avoid this, remove the media from the device when turning off the server/device.

● **Verifying data after a backup**

Some backup software products provide data verification functions after a backup is completed. Such functions will read and verify the data written to the media after a backup is completed. This will increase the usage of the media, thus reducing the number of times it can be used for backups. Depending on the hardware being used, some devices perform "read after write" operations on data; note the points of this section as necessary.

● **Ejecting media after a backup**

Some backup software products provide functions for ejecting media after a backup is completed. Such functions will rewind the tape after a backup is completed and then eject the media from the drive. Be sure to execute this function for autoloader/library devices. Depending on the structure of some servers, this function may cause the media to eject from an internal device of the server and hit the chassis door. If this is the case, open the door when ejecting, or do not eject the media.

- **Media label types and positions**

When writing information such as the name on media, use the label that came with the media. The area in which a label can be posted on the media of each device varies.

Failing to post labels in the designated area can damage the device.

- **Data storage**

When storing data for long periods of time, store the media in a location least affected by temperature, humidity and magnetic fields.

8.6 Restoring the System

In the unfortunate event where the system file, system configuration, or environment changes during startup are corrupted, use the repair information stored on the recovery disk created at the installation to restore the system.

POINT

- ▶ Create a recovery disk when you have installed an OS or changed the system configuration. Refer to "4.2 Creating a Disk for System Recovery" (→pg.75).
- ▶ If the procedures of restoring the system are described in the manual of the backup devices or Readme.txt of the device drivers, refer to these procedures.

8.6.1 For Windows Server 2003

● Items required

- Windows Server 2003 CD/DVD (Installation disc)
- Automated System Recovery (ASR) floppy disk (created beforehand)
- Backup media (created beforehand)
- Driver disk (for an array controller)
For details on required driver disk and how to create a driver disk, refer to "4.4 Creating Maintenance Tools and Driver Disks" (→pg.80).

1 Turn on the server and insert the Windows Server 2003 CD/DVD (Installation disc) immediately.

Check there are no floppy disks in the floppy disk drive.

2 When the active area is specified on the hard disk, the following message appears. Press any key while this message is displayed.

```
Press any key to boot from CD...
```

Setup window for Windows Server 2003 appears.

3 The following message appears at the bottom of the window. Press the [F6] key.

```
Press F6 if you need to install a third party
SCSI or RAID driver ...
```

IMPORTANT

- ▶ This message will be displayed for a short time after the setup window (blue screen) appears. Press the [F6] key immediately after the window turns blue.

4 When a message prompts you to press the [F2] key, press the [F2] key.
A message prompts you to insert the ASR floppy disk.

5 Insert the ASR floppy disk and follow the window instructions.

6 Install the driver.

Drivers to be installed vary depending on the array controller in use. Install an appropriate driver described below.

- When an Onboard Software RAID is used:
LSI Logic Embedded MegaRAID
- When no array is configured:
No driver installation is required.

For the procedure for installing a driver, refer to the following "Manual OS Installation".
<http://www.fujitsu.com/global/services/computing/server/ia/driver/>

7 Follow the window instructions to restore the system.

- When prompted to change the floppy disk, follow the instructions and change it.
- If a message appears indicating that the driver has not passed Windows Logo testing to verify its compatibility with Windows, select [Yes] to continue the installation procedure.
- When prompted to insert media, set the backup media created beforehand and follow the messages to continue.

POINT

Notes on Automated System Recovery

- ▶ Automated System Recovery does not restore data files.

8.7 Reinstalling the OS

This section explains the procedure for reinstalling the OS.

8.7.1 Checking before OS Reinstallation

■ Removing the optional devices

Remove the following optional devices before reinstalling the OS. Install or connect them after OS installation.

- Internal hard disk units that do not contain the OS installation folder
- 5-inch internal device options
- Optional USB connected devices

■ Deletion of data from the hard disk unit

Reinstalling a disk will delete all the contents of that disk. Please be careful. Save the necessary data and system configuration in a different location. Some drivers and software are not installed together with the OS. Install them after OS installation.

■ Other notes

Other notes are the same as those that apply for first time installation. Please check in advance.

8.8 Maintenance Service

This section explains the details of the maintenance service.

If the cause of the failure is uncertain or if the original condition cannot be restored, contact the seller or an office listed in the "Contact Information" of "Start Guide".

8.8.1 Contacting Maintenance Support

Before contacting maintenance support, check the following.

POINT

- ▶ Fill in the "Configuration Sheet" and "Accident Sheet" of "Configuration Sheets".

● Item

- Product name and product ID of the server
They are described on the label on the server. For the label location, refer to "Start Guide".
- Hardware configuration (Types and locations of internal options)
- Configuration information (BIOS Setup Utility settings)
- OS
- LAN/WAN system configuration
- Phenomena (what happened when doing what, what was displayed, etc.)
- Date and time of an accident
- Environmental settings of the server
- LED statuses

Appendix

This appendix explains the specifications for the server and for its internal options.

A	Server Specifications	172
B	Specifications for Internal Options	174
C	Setting Notifications for Events of Failures	177
D	Recycling	192

A Server Specifications

This section explains the specifications for the server.

table: Server specifications

Item		Functions and specifications			
Product name		PRIMERGY ECONEL 100 S2			
Product ID		PGUE1021B	PGUE1022B		
Chipset		Intel 3200 + i82801			
CPU	Standard	Intel® Celeron® 430 (1.80GHz/512KB)	Intel® Pentium® E2180 (2.00GHz/1MB)		
	CPU Conversion kit	None	Intel® Core™ 2 Duo Processor E4600 (2.40GHz/2MB)	Intel® Xeon® E3110 (3.00GHz/6MB)	Intel® Xeon® 3065 (2.33GHz/4MB)
	Number of CPU cores	1	2		
	FSB	800MHz	Intel® Pentium® E2180: 800MHz Intel® Core™ 2 Duo Processor E4600: 800MHz Intel® Xeon® E3110, Intel® Xeon® 3065: 1333MHz		
	Number of CPUs	Standard: 1 (maximum: 1)			
Memory	Type	512MB (standard) / 1GB / 2GB PC2-6400 (DDR2-800) unbuffered ECC DIMM			
	Number of memory modules	Standard: 1 (maximum: 4)			
	Adding size	512MB / 1GB / 2GB			
	Maximum	8GB (for 2GB DIMM)			
PCI slot		PCI 32bit/33MHz × 1, PCI-Express (x1) × 1 PCI-Express (x4) × 1, PCI-Express (x8) × 1			
5-inch storage bay	Number of bays	2 (empty bay:1)			
	Standard	DVD-ROM			
3.5-inch storage bay	Type	80GB / 160GB / 500GB (7.2krpm)			
	Number of bays	4			
	I/F	SATA			
Maximum		2TB (500GB × 4)			
Disk array controller		Onboard Software RAID (standard) : Embedded MegaRAID SATA SAS array controller card: MegaRAID SAS			
Onboard controller	Video	ATI ES1000 (32MB Video Memory) Resolution: 640 × 480, 800 × 600, 1024 × 768, 1280 × 1024 Display color: Differs depending on resolution and OS			
	LAN	Intel 82566DM × 1 (Gigabit Ethernet)			
External I/O port	Video	1 (Analogue RGB DSUB 15 pin)			
	USB	8 (USB 2.0, Front × 2, Rear × 6)			
	Serial	1 (DSUB 9 pin)			
	Parallel	1 (DSUB 25 pin, optional)			
Power Supply unit	LAN	1 (Modular (RJ-45) 8 pin)			
	Number of units	Standard: 1 (maximum: 1)			
Fan unit	Redundancy	None			
	Number of units	Standard: 2 (maximum: 2)			
Floppy Disk drive	Redundancy	None			
		Standard			
Internal clock precision		± 2 to 3 minutes/month			
Power consumption / Heating value		178W / 640.8k J/h			
Weight		16.2kg			
Dimensions (Width × Depth × Height(mm))		203 × 386 × 390			
Noise		21dB (A)			

The specifications for this server are liable to be updated without any notice. Please be forewarned.

■ Supported OS

The supported operating systems for this server are as below.

- Windows Server 2003, Standard Edition (SP2 or later)
- Windows Server 2003, Standard x64 Edition (SP2 or later)
- Windows Server 2003 R2, Standard Edition (SP2 or later)
- Windows Server 2003 R2, Standard x64 Edition (SP2 or later)
- Windows Small Business Server 2003 R2 (SP2 or later)
- Windows Small Business Server 2003 (SP2 or later)
- Red Hat Enterprise Linux ES (v.4 for x86)
- Red Hat Enterprise Linux ES (v.4 for EM64T)
- Red Hat Enterprise Linux 5 (for x86)
- Red Hat Enterprise Linux 5 (for Intel64)

For latest Support OS information, please refer to "Support Matrix" at <http://www.fujitsu.com/downloads/PRMRGY/support-matrix.pdf>.

B Specifications for Internal Options

This section explains the specifications for internal options for the server. When you have bought an internal option as a standard option, check that the package contains the following items before use. Should it happen that items are missing, contact an office listed in the "Contact Information" of "Start Guide".

B.1 Memory

■ Package

- Memory module (1)

■ Specifications

table: Memory specifications

Item	Function and specifications		
Product name	Memory Module-512MB	Memory Module-1GB	Memory Module-2GB
Product ID	PG-RM51BH	PG-RM1BH	PG-RM2BH
Capacity	512MB	1GB	2GB
Clock frequency	800MHz (Dual edge)		
PIN count	240PIN		

B.2 Internal Hard Disk Units

■ Package

- Hard disk unit (1)

■ Specifications

table: Internal hard disk unit specifications

Item	Function and specifications		
Product name	HDD SATA 7.2k 80GB 3.5inch	HDD SATA 7.2k 160GB 3.5inch	HDD SATA 7.2k 500GB 3.5inch
Product ID	PG-HDE87A	PG-HDE67A	PG-HDE57A
Interface	SATA (Serial ATA)		
Memory capacity *1	80GB	160GB	500GB
Maximum data transfer speed	3Gbit/s		
Average latency speed	4.2ms		
Rpm	7,200rpm		
Dimensions	101.6 × 147 × 26.1 (mm)		
Weight	450g		635g

*1: The value indicates memory capacity of the formatted hard disk unit (1GB = 1000³ bytes)

B.3 Parallel Port Option

■ Package

- Parallel Port (1)

■ Specifications

table: Parallel Port specifications

Item	Function and specifications
Product name	Parallel Port
Product ID	PG-PP08

B.4 Power Cord Selection

The power cord for this unit has been packed separately and has been selected according to the country of destination. It must be used to prevent electric shock. Use the following guidelines if it is necessary to replace the original cord set. The female receptacle of the cord set must meet CEE-22 requirements (see Figure).

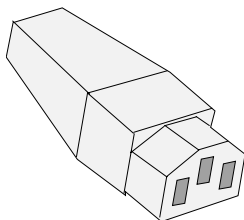

■ For the United States and Canada

Use a UL listed and CSA labeled cord set consisting of a three conductor cord with a maximum length of 15 feet. For units which stand on a desk or table, type SVT or SJT cord sets should be used.

For units which stand on the floor, only SJT type cord sets should be used.

The cord set must be selected according to the current rating for your unit.

Please consult the table below for the selection criteria for power cords used in the United States and Canada.

table: Selection Criteria for Power Cords Used in the United States and Canada

Cord Type	Size of Conductors in Cord	Maximum Current Rating of Unit
SJT	18 AWG	10 Amps
	16 AWG	12 Amps
	14 AWG	12 Amps
SVT	18 AWG	10 Amps
	17 AWG	12 Amps

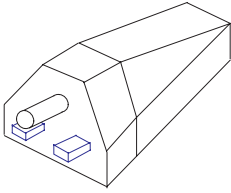

- Parallel
For units set at 115 V: Use a parallel blade, grounding type
Attachment plug rated 15 A, 125 V.

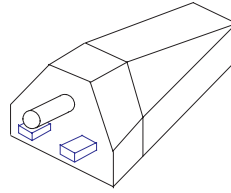

- Tandem
For units set at 230 V: Use a tandem blade, grounding type
Attachment plug rated 15 A, 250 V.

● **For units set at 230 V (outside of the United States and Canada):**

Use a cord set consisting of a minimum AWG according to the table above and a grounding type attachment plug rated 15 A, 250 V. The cord set should have the appropriate safety approvals for the country in which the equipment will be installed and should be marked HAR.

■ **For the United Kingdom**

Should the plug on the flexible cord not be of the type for your socket outlets, do not use an adapter but remove the plug from the cord and discard. Carefully prepare the end of the supply cord and fit a suitable plug.



- This appliance must be earthed.

🔍 **POINT**

- ▶ The wires in this mains lead are colored in accordance with the following code:
 - Green and Yellow: Earth
 - Blue: Neutral
 - Brown: Live

As the colors of the wires in the mains lead of this appliance may not correspond with the colored markings identifying the terminals in your plug, proceed as follows:

- The wire which is colored Green and Yellow must be connected to the terminal in the plug which is marked with the letter E or by the earth symbol or colored Green or Green and Yellow.
- The wire which is colored Blue must be connected to the terminal which is marked with the letter N or colored Black.
- The wire which is colored Brown must be connected to the terminal which is marked with the letter L or colored Red.

C Setting Notifications for Events of Failures

This section explains how to receive hard disk failure and failure prediction notifications by using AlarmService, a component of ServerView Console. For the AlarmService configuration, follow the procedure below on the ServerView S2 management window.

POINT

- ▶ The procedure shown here is an example. Complete appropriate settings for ServerView Console according to your environment.
- ▶ The procedure here is for ServerView Console V4.5x. The procedure may differ depending on the ServerView Console version. For details, refer to "ServerView User's Guide" in PRIMERGY Startup Disc.

C.1 Setting for Alarm Group

Create and/or set alarms to be notified as an alarm group.

- 1** Start up ServerView S2.
For how to start up, refer to "ServerView User's Guide".
- 2** Click [EVENT MANAGEMENT] – [ALARM SETTINGS].

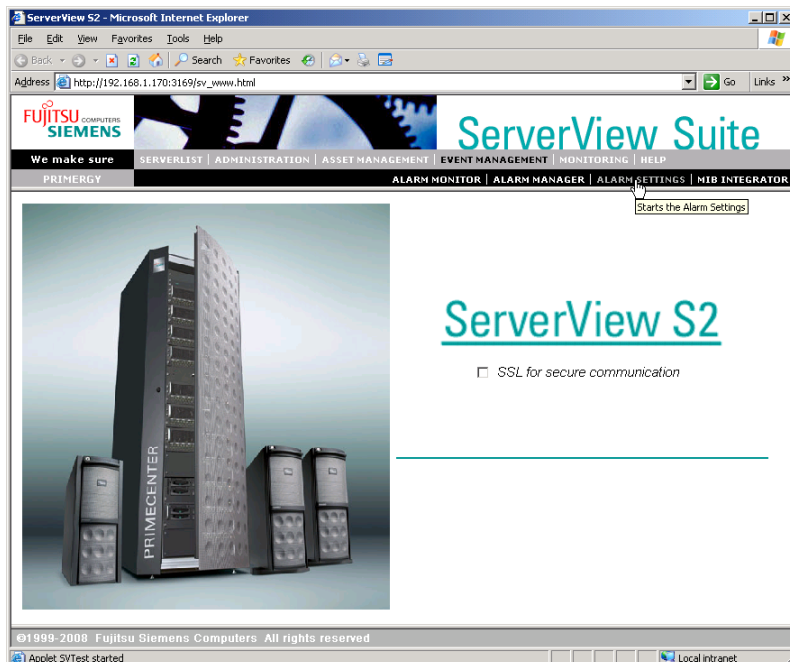

The [Start Alarm Settings] window appears.

- 3** Select [Edit / New Alarmgroup], and click [Go].

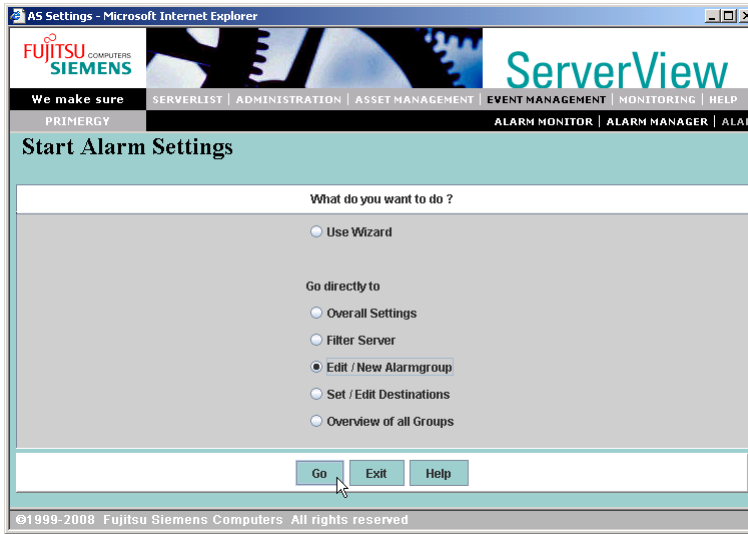

The [Select group] tab window in the [Edit / New Alarmgroup] window appears.

- 4** Create a new alarm group.

Specify and type a group name ("Disk_Failure" in the following screenshot) in "Type in new alarm group name", and click the [Select server] tab.

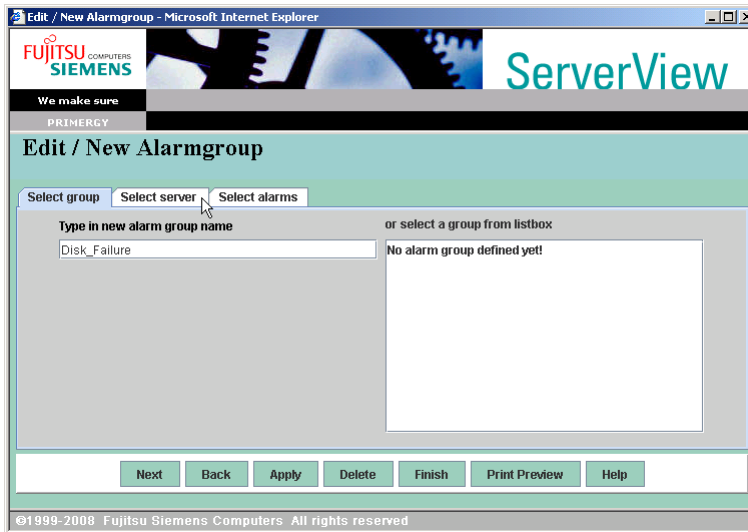

The [Select server] tab window appears.

- 5 Select the server to be included in the alarm group.
 Select the server from [Known server] ("TESTSERVER" in the following screenshot), and click [>>>]. Then, click the [Select alarms] tab.

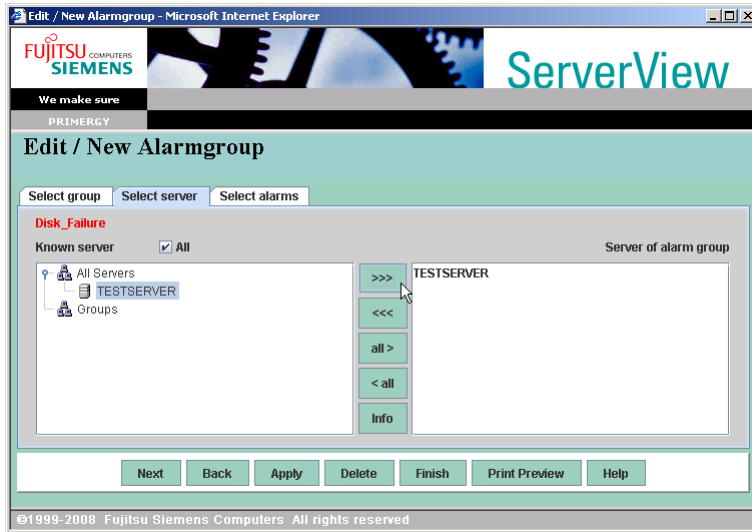

The [Select alarms] tab window appears.

- 6 Specify the "mib" file that includes the hard disk failure events to be notified.
 Select [File], and select [RAID.mib] from the pull down menu.

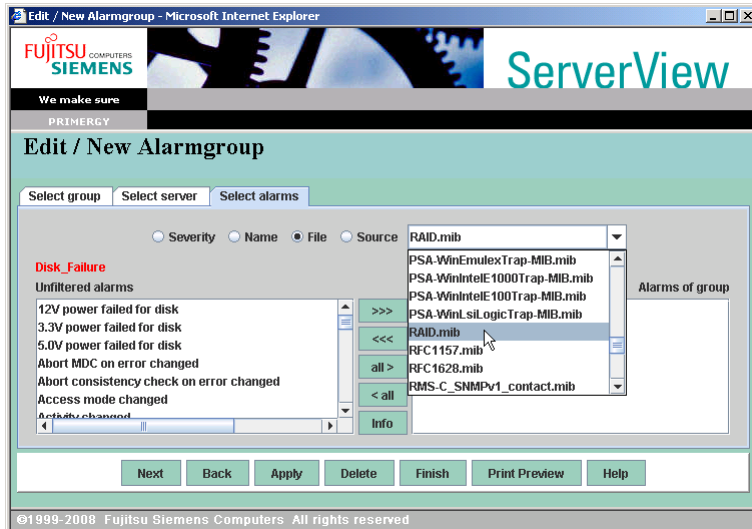

7 Specify the events to be notified.

Select the following alarms from the [Unfiltered alarms], and click [>>>] to add to [Alarms of group].

- Disk missing after reboot
- Predictive failure
- State change from hot spare to failed
- State change from hot spare to offline
- State change from offline to failed
- State change from operational to failed
- State change from operational to failed
- State change from operational to offline
- State change from rebuild to failed
- State change from rebuild to offline

POINT

- ▶ There are two "State change from operational to failed". Add both of them.

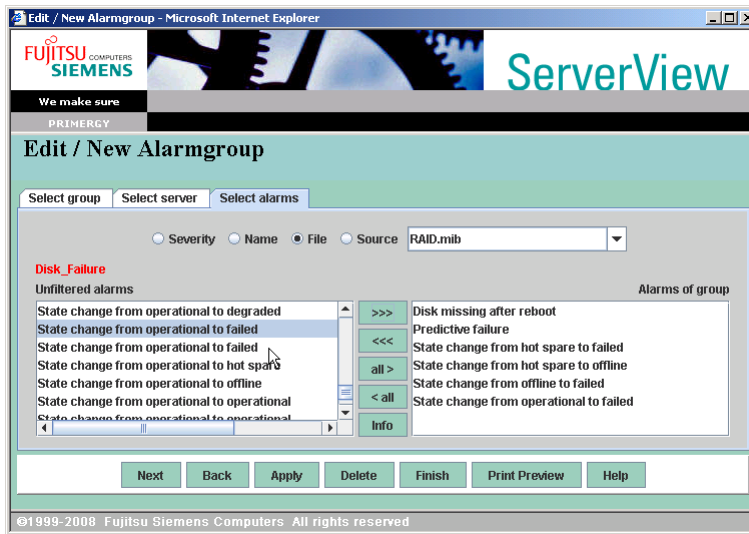

8 When you complete the step 3 to 6 above, which are [Select group], [Select server], and [Select alarms], click [Apply] – [Finish].

After the Alarm group is created, the [Start Alarm Settings] window will appear. "Disk_Failure", the alarm group created here, only includes the alarm group defined in the step 6 among the "TESTSERVER" servers.

IMPORTANT

- ▶ When you change an IP address and/or a host name of the target server to be monitored that the alarm group is set to, the change will not be reflected to the alarm group. You need to edit the alarm group and specify the server again.

C.2 Setting Actions

Set actions to the alarm group that is defined in "C.1 Setting for Alarm Group" (→pg.177). Examples are shown here for popup, broadcast, and sending mails. For detailed settings, refer to "ServerView User's Guide" in PRIMERGY Startup Disc.

■ Popup

- 1 On the [Start Alarm Settings] window, select [Set / Edit Destinations], and click [Go].



The [Set / Edit Destination] window appears. As the default setting, alarms are set to pop up.

- 2 Check that the alarm group you defined in "C.1 Setting for Alarm Group" (→pg.177) is selected, and click [Finish].

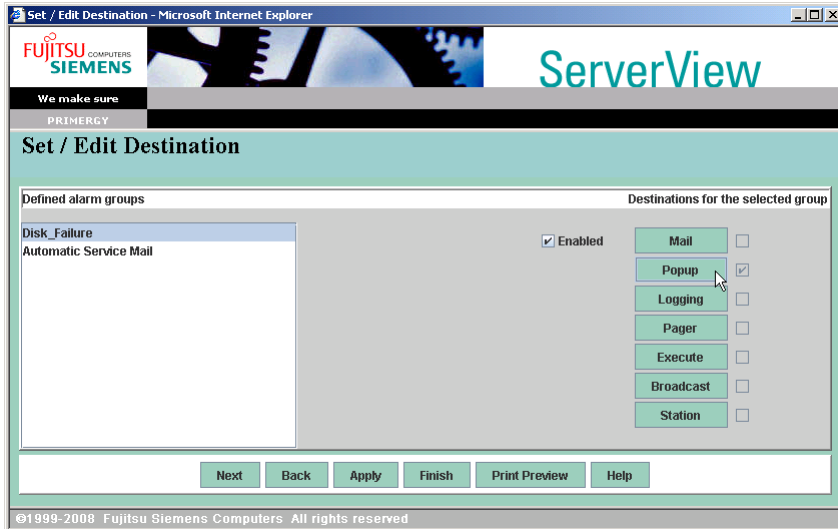

The [Start Alarm Settings] window appears. As the default setting, all the alarms, including the ones not in any alarm groups, are set to pop up.

- 3 Select [Overall Settings], and click [Go].
- 4 Select the [Default alarm handling] tab, and uncheck [Pop up a message].

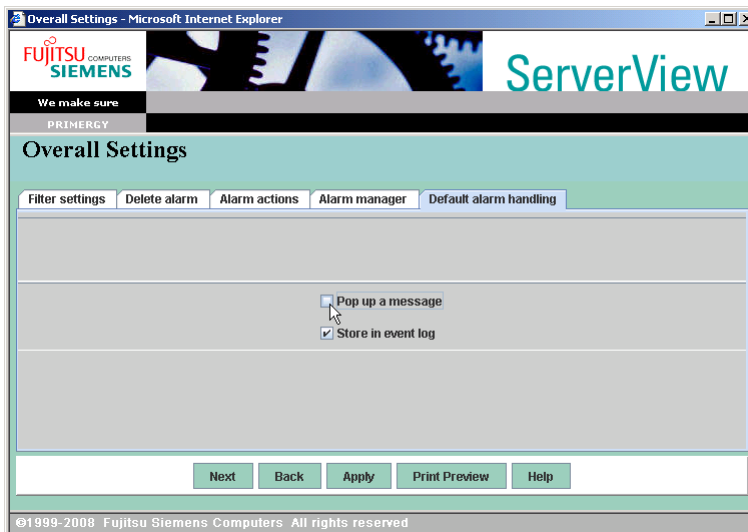

IMPORTANT

- ▶ Only when Messenger service is running, messages will pop up. For Windows Server 2003, Messenger service is disabled as the default setting. Follow the procedure below to change the setting.
 1. Click [Start] – [Administrative Tools] – [Computer Management].
 2. On the left side tree, click [Services and Applications] – [Services].
 3. On the right side window, click [Messenger].
 4. Select [Properties] from the [Action] menu.
 5. Click the [General] tab.
 6. Set [Startup Type] to [Automatic], and click [OK].

5 Click [Apply], and click [Back].

The only alarms defined in alarm groups will pop up.

■ Broadcast

- 1** On the [Start Alarm Settings] window, select [Set / Edit Destinations], and click [Go].



The [Set / Edit Destination] window appears.

- 2 Check that the alarm group you created in "C.1 Setting for Alarm Group" (→pg.177) is selected in [Defined alarm groups], and click [Broadcast] from [Destinations for the selected group].

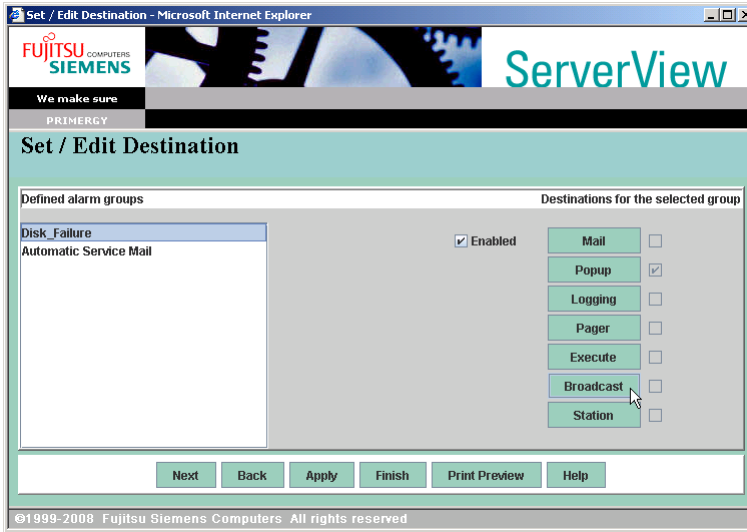

The [Set / Edit Broadcast for group Disk_Failure] window appears.

- 3 Click [New] to configure new broadcast settings.

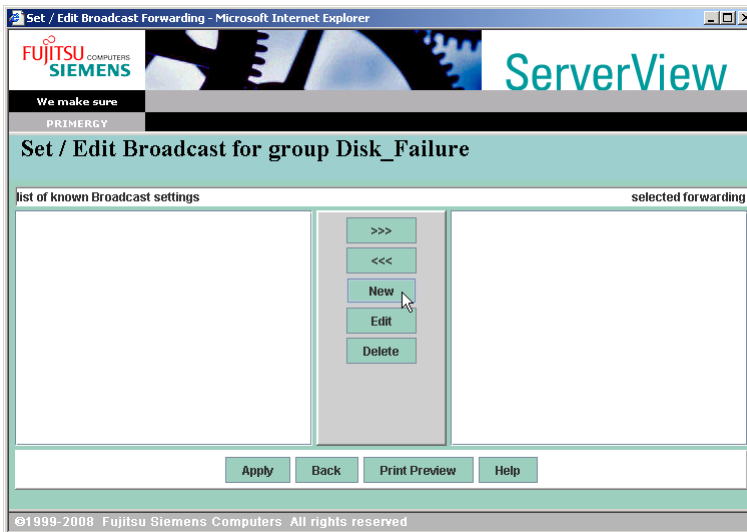

4 Configure the detailed broadcast settings.

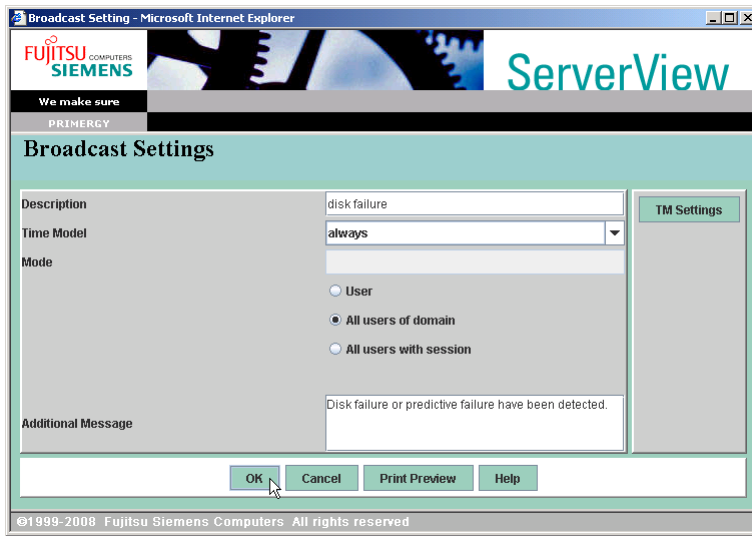

table: Broadcast settings

Item	Description
Description	Enter the name of the broadcast setting.
Time Model	Do not change from "always".
Mode	Specify the mode of the broadcast. <ul style="list-style-type: none"> • User Only a single specified user is notified of the information. Enter a user name in the field next to [Mode]. • All users of domain (only when using Windows) All users in the same domain as the forwarding destination are notified. • All users with session All users connected via the forwarding session are notified.
Additional Message	Enter additional text for the message.

5 Click [OK] after configuring each of the items.

The [Set / Edit Broadcast for group Disk_Failure] window appears.

- 6 Check that the broadcast settings that were just made are displayed, click [Apply], and click [Back].

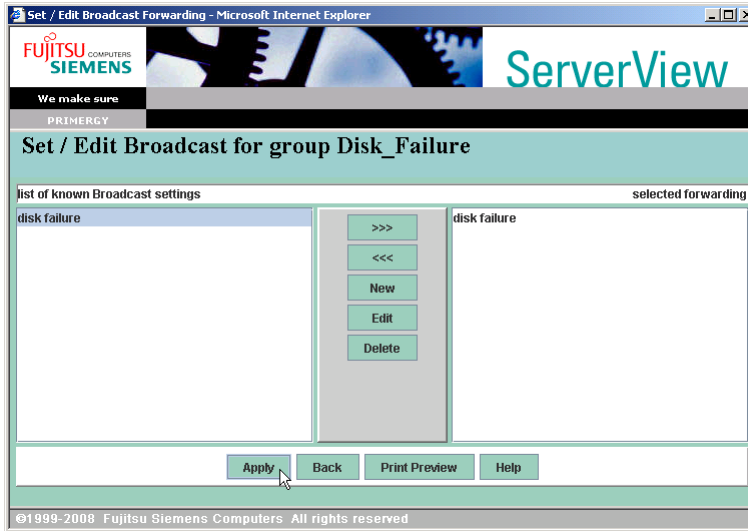

The [Set / Edit Destination] window appears.

- 7 Click [Next].

The [Overview] window appears.

- 8 Check the configuration, and click [Finish] to exit.

The broadcast settings are completed.

As the AlarmService default setting, all the alarms, including the ones not in any alarm groups, are set to pop up.

- 9 Select [Overall Settings], and click [Go].

- 10** Select the [Default alarm handling] tab, and uncheck [Pop up a message].

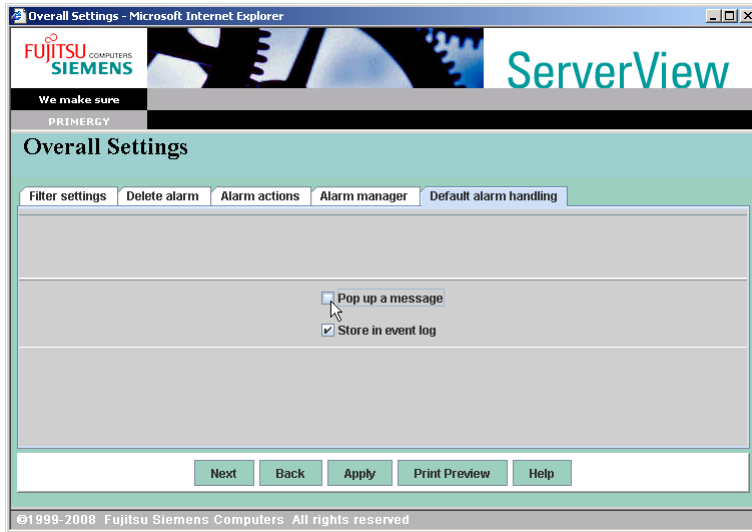

IMPORTANT

- ▶ Only when Messenger service is running, messages will pop up. For Windows Server 2003, Messenger service is disabled as the default setting. Follow the procedure below to change the setting. To pop up the broadcast messages that are received via more than one terminals, you need to change the settings of all the terminals to pop messages up.
 1. Click [Start] – [Administrative Tools] – [Computer Management].
 2. On the left side tree, click [Services and Applications] – [Services].
 3. On the right side window, click [Messenger].
 4. Select [Properties] from the [Action] menu.
 5. Click the [General] tab.
 6. Set [Startup Type] to [Automatic], and click [OK].

- 11** Click [Apply], and click [Back].

The only alarms which are received by broadcast will pop up.

- 12** On the terminals that received broadcast, such a pop up as shown below will be displayed.

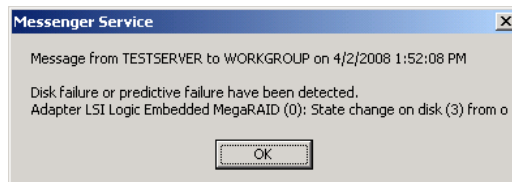

■ Mail



▶E-mail notification tool is not supported by authentication functions such as POP before SMTP, or SMTP auth.

- 1 On the [Start Alarm Settings] window, select [Set / Edit Destinations], and click [Go].



The [Set / Edit Destination] window appears.

- 2 Check that the alarm group you created in "C.1 Setting for Alarm Group" (→pg.177) is selected in [Defined alarm groups], and click [Mail] from [Destinations for the selected group].

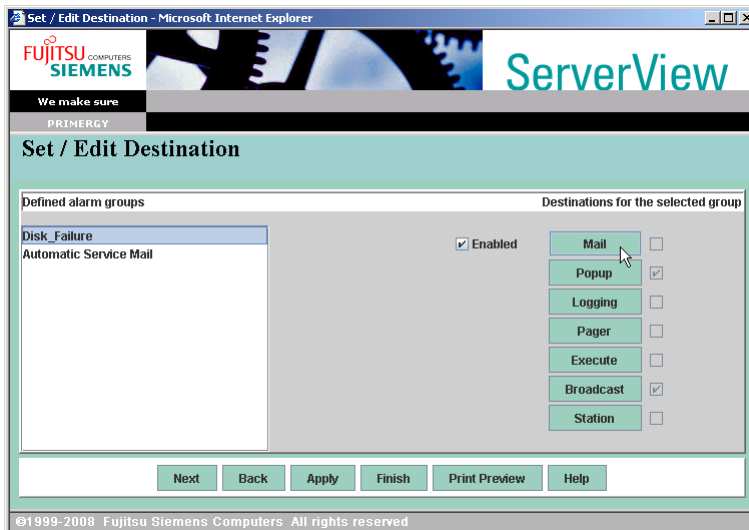

The [Set / Edit mail for group Disk_Failure] window appears.

3 Configure new mail settings. Click [New].

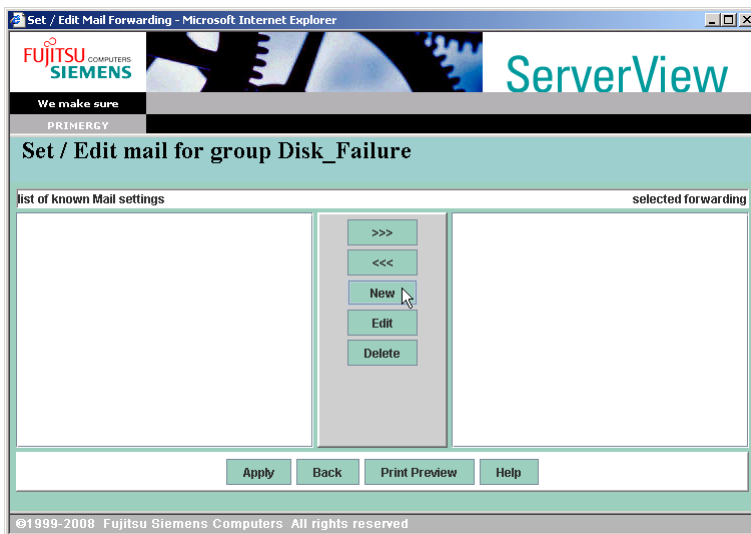

The [Mail Settings] window appears.

4 Enter each item for e-mail notifications.



table: Mail setting

Item	Description
Description	Enter the name of the mail setting.
Subject	Enter the subject of the outgoing mail.
Mail To	Enter the destination address of the mail.
Cc	Enter the Cc address of the mail to send the copy to multiple addresses.
Time Model	Do not change from "always".
Additional Message	Server : \$_SRV IP address : \$_IPA Time : \$_TIM

5 Click [Properties].
The [Mail Properties (SMTP)] window appears.

6 Enter a mail account for e-mail notifications.

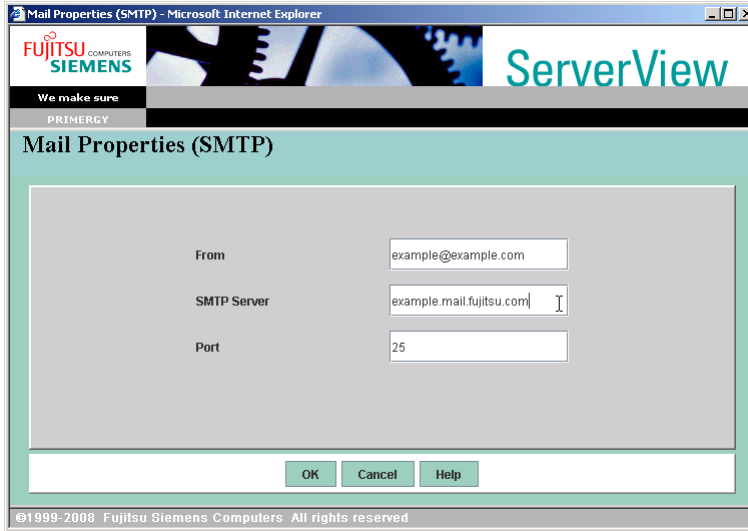

table: Mail properties (SMTP)

Item	Description
From	Enter the mail address for e-mail notifications.
SMTP Server	Enter the mail server address.
Port	Normally, it is not necessary to change from "25".

7 Click [OK].
The display returns to [Mail Settings] window.

8 To confirm the mail account settings in the step 6, click [Test Address].
The test mail is sent to the address you set.

9 Click [OK].
The display returns to [Set / Edit mail for group Disk_Failure] window.

10 Click [Apply], and click [Back].
The display returns to [Set / Edit Destination] window.

11 Click [Next].
The [Overview] window appears.

12 Check the configuration, and click [Finish] to exit.

The settings are completed. At a hard disk failure, such an e-mail as shown below will be sent.

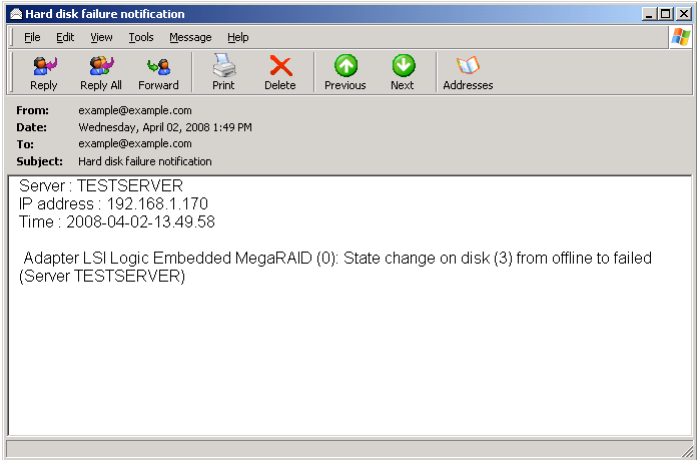

D Recycling

This section explains how to recycle this server.

■ Disposing of the server

When scrapping this server, contact an office listed in the "Contact Information" of "Start Guide". This server must be disposed of as industrial waste.

Furthermore, if the server is disposed of as it is, someone else may gain access to the information contained on the hard disk units. It is therefore recommended that all drives be formatted before disposal.

However, just formatting or deleting files may not avoid the risk that the data is restored and used for wrongful purposes. If confidential or private information is saved, in order to make it impossible to be restored, it is recommended to use third-party data wiping tools.

■ Disposing of used-up batteries

Used-up batteries must be disposed of as industrial waste and therefore require special processing. Let a licensed industrial waste disposal company take care of disposal.

■ Disposing of liquid crystal displays

Liquid crystal displays must be disposed of as industrial waste and therefore require special processing. Let a licensed industrial waste disposal company take care of disposal.

Index

A

Application wizard	
Expert mode	64
ASR	75
Automated system operation	89
Automated System Recovery Set	75
Auto-run Function from CD/DVD drives	87

B

Backup	164
BIOS information	
Recovering	79
Storing	78
BIOS Setup Utility	127
Advanced menu	132
Advanced Processor Options submenu	135
Advanced System Configuration submenu	134
Boot Features submenu	131
Boot menu	141
Exit menu	142
Exiting	128
Key operations	128
Main menu	130
PCI Configuration submenu	136
Peripheral Configuration submenu	133
Power menu	140
Security menu	138
Starting	127
System Management submenu	137

C

Changing passwords	162
Cleaning	
floppy disk drive	146
keyboard	145
mouse	145
server	145
Component names	21

D

Deleting passwords	162
Disk Manager	58
DOS Diskette	86
Drive Letter Assignment	87
DSNAP	19, 98
Installation	98
Usage	98

E

E-mail	
Hard disk failure notifications	177
Error messages	155
Event logs	157
Expert mode	54

F

Fan monitoring	95
----------------	----

H

Hardware Configuration Tool	83
Hardware features	12
High Reliability Tools	18
ServerStart installation	19
HRM/server	97

I

Installable internal hard disk units	116
Installable 5-inch internal device options	122
Installation	
DSNAP	98
ServerStart	80
ServerView	96
Installation order	
Expansion cards	109
Hard disk units	116
Memory modules	105
Installation Partition Size	42
Installing memory modules	104
Intel(R) PROSet	90
Installation	90
LAN driver advanced setup	90
VLAN	91

M

Maintenance	144
Maintenance service	170
Maintenance tools	80
Memory dump	70, 157
Memory dump file setting	71
Memory dump setting	70
Memory monitoring	95
Multiple LAN adapter configuration	
Adapter numbers	44

N

Network configuration 15

O

Operating the Server

Precautions 87

OS installation

Installation method 41

Precautions 42

Preparation 37

OS installation wizard

Expert mode 59

P

Paging file setting 70, 72

Password settings 162

POST error messages 150

Power supply monitoring 96

Q

Quick Installation mode 48

R

RAID configuration

Notes 42

RAID error monitoring 95

RAID Management Tool 18, 94

Reinstalling the OS 169

Restoring the system 167

S

Security 161

Hardware 161

Password settings 161

Server disposal 163

Server disposal 163

Server Management Tools 77

Cautions 77

Server Monitoring Tools 18, 95

ServerStart 14

Cautions 43

Features 14

Installation 80

Supported expansion cards 45

Uninstallation 82

ServerView 18, 95

Installation 96

SNMP Service 158

System diagnosis support tools 19

System event logs 160

System recovery disk 75

T

Temperature monitoring 95

Troubleshooting 148

Turning off the server 29

Turning on the server 28

Turning the Power On via a LAN 89

U

Uninstallation

ServerStart 82

Unintentional power-off prevention 89

Uninterruptible Power Supply (UPS) 88

V

Voltage monitoring 96

W

Wakeup On LAN 89

PRIMERGY ECONEL 100 S2
User's Guide

B7FH-5371-01ENZ0-00

Issued on April, 2008

Issued by FUJITSU LIMITED

- The contents of this manual may be revised without prior notice.
- Fujitsu assumes no liability for damages to third party copyrights or other rights arising from the use of any information in this manual.
- No part of this manual may be reproduced in any form without the prior written permission of Fujitsu.