



**White Paper
WiMAX Spectrum**

RF Spectrum Utilization in WiMAX

Fujitsu Microelectronics America, Inc.

November 2004

Abstract

This paper discusses the implementation of IEEE 802.16a/d/e WirelessMAN™ (broadband wireless access), also referred to as WiMAX (Worldwide Interoperability for Microwave Access), in terms of frequency spectrum. Spectrum-regulating bodies around the world have earmarked frequency bands, both licensed and unlicensed, for broadband deployment. Semiconductor suppliers, such as Fujitsu Microelectronics America, Inc. (FMA), offer flexible chipsets and reference designs for WiMAX-certifiable systems to equipment vendors. These reference designs allow for a selection of RF front-ends to be combined with a highly integrated baseband processor and MAC processor system on a chip (SoC), to accommodate a wide range of markets based on different portions of the spectrum. The RF front-end interface to baseband (SoC) is also discussed along with power considerations and future spectrum allocation.

Contents

<u>Introduction</u>	3
<u>Standardization with Spectrum Diversification</u>	3
<u>Focus on 802.16d – Non-Line-of-Site Multipoint</u>	4
<u>Spectrum to Deliver PMP Broadband Networking</u>	4
<u>Spectrum Options – Band Characteristics</u>	5
<u>Licensed and Unlicensed Spectrum</u>	5
<u>Wireless ISPs and Major Carriers</u>	6
<u>Band Distinctions</u>	6
<u>WiMAX Forum Spectrum Initiative</u>	7
<u>Transmitting and Receiving Signal Strengths</u>	7
<u>Receive Requirements</u>	7
<u>Transmit Requirements</u>	8
<u>SoC to RF Interface</u>	8
<u>Future Spectrum for WiMAX – More Room and Service Options</u>	8

Introduction

Standardization with Spectrum Diversification

Just as the Wi-Fi Wireless Local Area Network (WLAN) boom took off on the wings of the IEEE 802.11 standard, an emerging Metropolitan Area Network (MAN) rocket is preparing to launch based on the IEEE 802.16 WirelessMAN standards. While 802.16x lays out the specifications for standardization and interoperability, the WiMAX Forum, the global Broadband Wireless Access (BWA) industry association, provides the quality control and certification to ensure successfully standardized deployment. The primary task of the WiMAX Forum is to rally a host of worldwide stakeholders – composed of chipmakers, software developers, equipment manufacturers and service providers – in support of the IEEE WirelessMAN/ETSI HyperMAN™ standards, and to ensure worldwide compatibility and interoperability of equipment to accelerate deployment of broadband metropolitan area networks. WiMAX-certified equipment not only ensures compatibility but also creates a broad competitive field that leads to lower cost for service providers and subscribers. IEEE 802.16 and WiMAX will propel BWA forward to accelerate affordable worldwide deployment.

However, standardization does not mean worldwide “sameness” and automatic interoperability for “all” deployed WiMAX-certified equipment. The standards define and suggest key profiles for the Media Access Control (MAC) layer, which packs and unpacks raw data based on standard protocols to accommodate data, voice and video, and for the Physical Layer (PHY), which handles the air interface and modulation schemes based on subscriber needs and Radio Frequency (RF) link quality. The IEEE 802.16 standard generates profiles but also allows for vendor customization to meet specific or localized market needs, or to allow the vendor to differentiate itself with value-added features.

What is more, on a global scale, the actual radio frequency interface varies by region. That is where spectrum-governing authorities, such as the U.S. Federal Communications Commission (FCC), play a key role in determining useable spectrum for various, and sometimes competing, services. Through the governing authorities, governments make available portions of spectrum that may or may not be in harmony with the rest of the world to serve a given segment. Such is the case with the global deployment of WiMAX. Though some fairly common RF ground does exist, there is also a great deal of diversity in spectrum allocation and regulation.

But it is not just regulation that creates RF band diversity in the global deployment of WiMAX-certified wireless MANs. Service carriers and Wireless Internet Service Providers (WISPs) within a region have band choices. Available and allocated spectrum includes various licensed and unlicensed (license-exempt) bands. A carrier may choose to use its licensed spectrum to provide service and/or opt to use unlicensed spectrum. Most WISPs opt to use unlicensed spectrum because it is free for the using and greatly reduces cost to the customer subscribers.

This diversity of spectrum for the deployment of WiMAX-certified MANs results in the demand for RF-diverse Base Stations (BS) and Subscriber Stations (SS). As illustrated in Figure 1, a Generic WiMAX SS system includes a control processor, a MAC unit, a baseband processor (BBP) and an analog RF front-end that serves as the means to place 802.16x into a specific

licensed or unlicensed band. Equipment vendors look to chip makers like Fujitsu Microelectronics America to provide complete reference designs, bill of materials, components, software/firmware and technical support so that they can rapidly manufacture WiMAX-certifiable equipment to meet the needs of these RF-diverse markets. The interface for serving a particular band segment is the RF front-end.

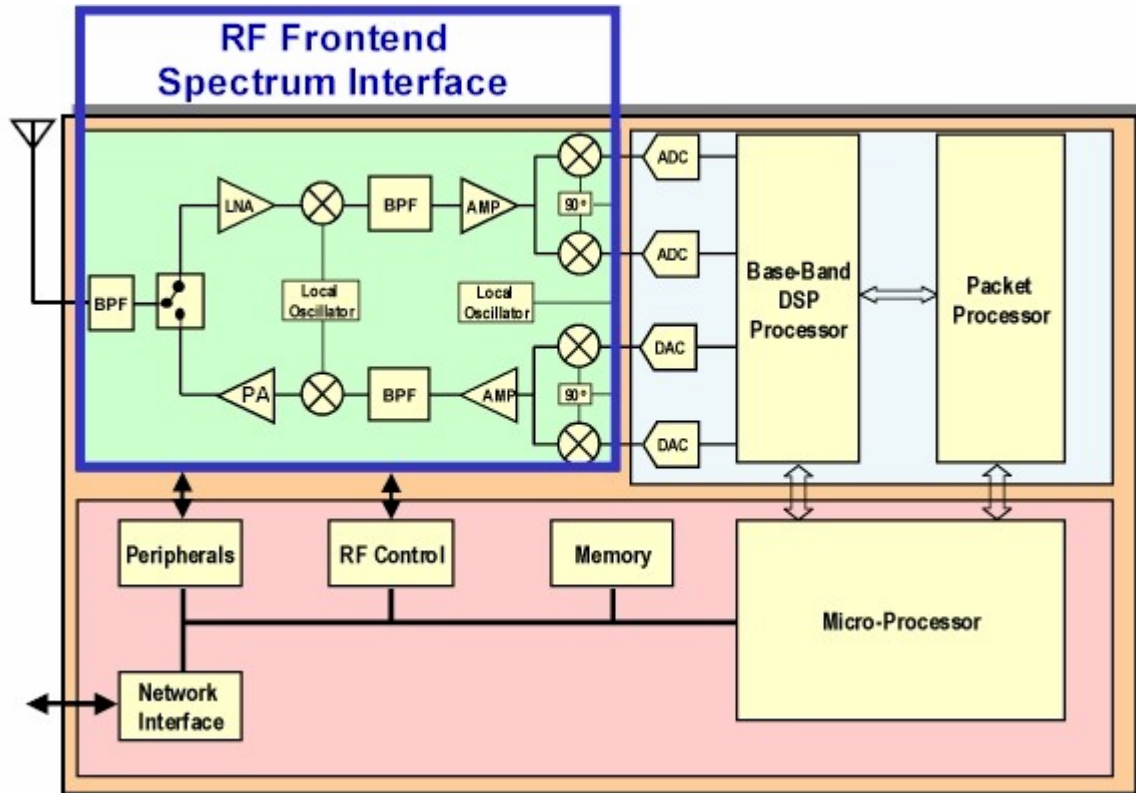

Figure 1 – Basic block diagram of a WiMAX subscriber station – different RF front-ends provide band flexibility

Focus on 802.16d – Non-Line-of-Site Point-to-Multipoint

Spectrum to Deliver PMP Broadband Networking

WiMAX-certified BWA applications include backhauling for cellular networks, wide-bandwidth backhauling for wired and wireless LANs, and for wireless MANs to bring BWA to homes and businesses as an alternative to DSL or cable access. However, the greatest market explosion will take place in the future 802.16x versions addressing portability and mobility, bringing BWA directly to the end user. This “last-mile” market is by nature a Point-to-Multipoint (PMP) architecture utilizing Non-Line-of-Sight (NLOS) RF propagation. WiMAX-certified networks will be emerging worldwide in both licensed and unlicensed bands within this spectrum, in many cases replacing existing proprietary pre-802.16 services.

Currently, focus has been given to frequency bands that exist in the 2 to 6GHz portions of the spectrum. This is where allocated bandwidths are relatively narrow as compared to those bandwidths that are available in the 10 to 66GHz range. Microwave frequencies below 10GHz are referred to as centimeter bands and those above 10GHz are millimeter bands. Millimeter bands, with their much wider allocated channel bandwidths, accommodate large data capacities. Therefore, millimeter bands are generally most suitable for very high data-rate line-of-sight backhauling applications (major pipelines), while centimeter bands are well suited for multipoint, NLOS, tributary and last-mile distribution.

The centimeter spectrum contains a significant tributary – and last-mile market worldwide. IEEE 802.16d supporting fixed NLOS BWA to supplant, or supplement, DSL and cable access for last-mile service is the foundation for the first wave of WiMAX deployment. Moving forward, IEEE 802.16e, to be ratified in 2005, will add mobility and portability to applications such as notebooks and PDAs for spectrums below 6GHz range. Both licensed and unlicensed spectrums will be utilized in these deployments.

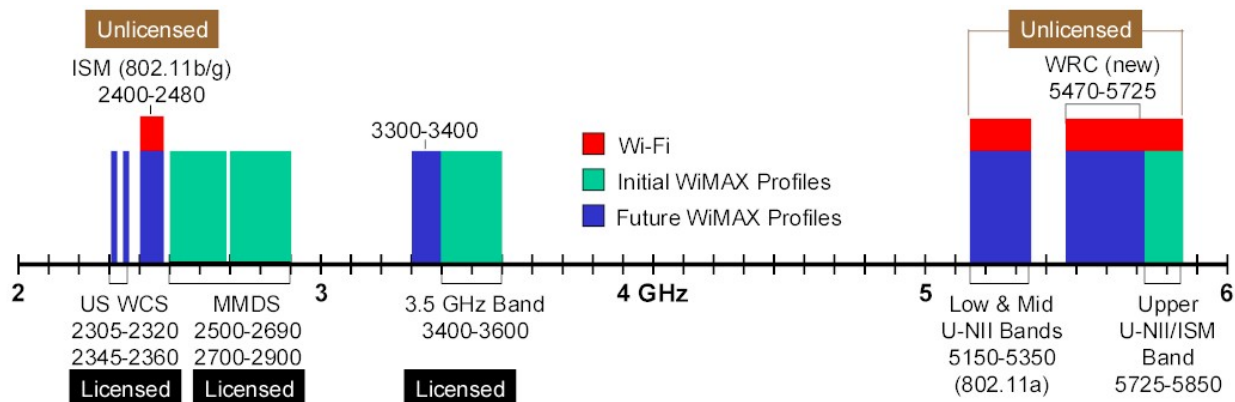

Figure 2 – 2 to 6GHz centimeter bands available for BWA

Spectrum Options – Band Characteristics

Licensed and Unlicensed Spectrum

Figure 2 shows the various bands available for BWA in the 2 to 6GHz range. Note that these bands are identified as either licensed or unlicensed (license exempt). Licensed bands are those that are currently “owned” by carriers that have paid for the use of these bands. Unlicensed bands are freely available for any experimental or enterprise application. IEEE 802.11a/b/g-based Wi-Fi resides in unlicensed bands and has proven to be very robust in spite of competing technologies within these bands. Within each band, channel spacing is relatively narrow, thus limiting data rates as compared to the higher frequency millimeter-band channels.

Wireless ISPs and Major Carriers

Many WISPs seek to utilize unlicensed bands because they are free, saving both money and time for local network deployment. This also reduces costs for the subscriber and provides a competitive alternative to DSL and cable modem services. Unlicensed spectrum is also attractive in the United States because there isn't much licensed spectrum available in the 2 to 6GHz range. On the other hand, major carriers that have licensed spectrum can market it at a premium for "business-class" service because it is perceived to be more robust and reliable, and rides on the reputation of a major brand name.

Band Distinctions

3.5GHz Band – The 3.5GHz band is a licensed spectrum that is available for BWA use in many European and Asian countries, but not in the United States. It is the most heavily allocated band representing the largest global BWA market. Covering 300MHz of bandwidth, from 3.3 to 3.6GHz, this band offers great flexibility for large-pipeline backhauling to Wide Area Network (WAN) services. With this licensed spectrum, major carriers will be able to offer competitive subscriber fees through the economy of scale and lower equipment costs that WiMAX certification brings.

Broad Global Utilization of 3.5GHz Bands

EMEA

Czech Republic, France, Germany, Hungary, Greece, Ireland, Norway, Poland, Romania, Russia, Spain, Switzerland, UK
Israel, Turkey, Nigeria, Mali

Americas

Argentina, Brazil, Canada, Chile, Colombia, Costa Rica, Ecuador, Mexico, Peru, Uruguay, Venezuela

Asia Pacific

Australia, China, Indonesia, India (3.3-3.4 GHz), Japan, Malaysia, New Zealand, Taiwan, China
3400-3430 and 3500-3530 to start
Hong Kong & Singapore – band allocated to fixed satellite only

5GHz U-NII & WRC Bands – The Unlicensed National Information Infrastructure (U-NII) bands have three major frequency bands: low and mild U-NII bands (5150 – 5350) (802.11a), WRC (new) (5470 – 5725), and upper U-NII / ISM band (5725 – 5850). Wi-Fi exists in the lower and middle U-NII bands, which have demonstrated viability for BWA. Many overlapping 5GHz frequency bands earmarked for BWA growth exist around the world. The newly allocated World Radio Conference (WRC) 5470 to 5725MHz band adds significant license-exempt bandwidth. Most WiMAX activities are in the upper U-NII 5725 to 5850 band because there are fewer competing services and interferences there, i.e. Wi-Fi and the outdoor power allowance are in the higher 2 to 4W range as compared to only 1W in the lower and middle U-NII bands. Analysts and marketers expect strong WiMAX growth in this unlicensed space.

WCS – The two Wireless Communications Service (WCS) bands are twin 15MHz slots, 2305 to 2320MHz and 2345 to 2360MHz. The 25MHz gap between these bands is assigned to the Digital Audio Radio Service (DARS), which poses a potential interference problem caused by DARS terrestrial repeaters. Primary license holders for the WCS bands include Verizon, BellSouth, AT&T and Metricom along with some smaller entities. Successful deployment in these bands will require exceptional spectral efficiency such as offered by Orthogonal Frequency Division Multiplexing (OFDM), an RF modulation technique used by both Wi-Fi and WiMAX.

2.4GHz ISM – The 2.4GHz Industrial, Scientific and Medical (ISM) band is unlicensed and offers roughly 80MHz of bandwidth for BWA deployment. Wi-Fi now exists in this band and has demonstrated robust service for WLANs. Future WiMAX profiles that specify interoperable MAC and BBP requirements will bring the two services together for complementary operation that delivers wide-area mobility to the user.

MMDS – The Multichannel Multipoint Distribution Service (MMDS) spectrum includes 31 channels of 6MHz spacing in the 2500 to 2690MHz range and includes the Instructional Television Fixed Service (ITFS). This spectrum has been significantly under-utilized for its original instructional TV purpose, and has been allocated for BWA service in the United States by the FCC. BWA providers have gained access to this spectrum through FCC auctions and/or by leasing channels from ITFS channel holders. Sprint and Nextel are key spectrum holders here. Analysts expect significant BWA market growth in this band over the next few years.

WiMAX Forum Spectrum Initiative

Because of the potential for very high growth and utilization, the WiMAX Forum is focusing its initial profiling and certification efforts on the MMDS, the 3.5GHz licensed bands and the unlicensed upper U-NII 5GHz band, where there is less interference, reasonable power levels and adequate bandwidth. This will help ensure a high growth rate for WiMAX-certified BWA service worldwide because these bands represent the largest potential markets and allow for lower costs through the economies of scale.

Transmitting and Receiving Signal Strengths

Power levels and power control for both transmit and receive are extremely important for system efficiency in any WiMAX network. Levels must be actively managed to ensure solid communications and to mitigate potential interference. In addition, power levels are dynamically adjusted on a per-subscriber basis, depending on the subscriber's profile and distance from the BS. Overall data throughput starts with adequate power levels.

Receive Requirements

As specified by the WiMAX standard, receive level specifications are the same across the centimeter bands, 2 to 11GHz. The receiver must be able to accurately decode an on-channel signal of -30 dBm (1uW) maximum and must be able to tolerate a signal as strong as 0 dBm

(1mW) at the receiver input without damage to the front-end. In addition, the Rx should be able to provide a minimum image rejection of 60 dB. The WiMAX standard specifies that “the image-rejection requirement be inclusive of all image terms originating at the receiver RF and subsequent intermediate frequencies.” Adherence to these requirements will ensure reliable near and far operation.

Transmit Requirements

Subscriber stations (SSs) that do not utilize subchannels (single carrier) must exhibit a minimum of 30 dB range of monotonic power control. For SSs that do utilize subchannels (OFDM), a category that will include all WiMAX-certified SSs in the 2 to 11GHz range, the transmitter must have a dynamic power control range of at least 50 dB in no less than 1-dB steps. Power-control accuracy must be within +/-1.5 dB over a 30 dB range or +/-3 dB over any range greater than 30 dB.

For the BS transmitter, output-power-level control must have at least a 10 dB range. Actual transmitted power will depend on the subscriber distance, propagation characteristics, channel bandwidth, and modulation scheme (BPSK, QPSK, 16QAM, 64QAM). BPSK is the least data-efficient method and is employed where the SS is farthest from the BS, thus requiring additional transmit power. 64QAM, on the other hand, offers very high data efficiency (bits per symbol) and is used when the SS is relatively close to the BS, thus requiring less transmit power.

SoC to RF Interface

Referring back to Figure 1, the interface between the RF front-end and the SoC involves control signals to handle operation and housekeeping functions for the transmitter and receiver along with I/Q signals interfacing with A/D and D/A data converters.

Receive data delivered by the demodulator circuit to the SoC should be differential “I” and “Q” signals. Attenuators can be employed on the receive side to handle calibration and gain control to ensure maximum bit usage and conversion efficiency of the Analog-to-Digital Converters (ADCs).

Future Spectrum for WiMAX – More Room and Service Options

Additional bands are being considered today by different regions around the world for the deployment of WiMAX and other similar broadband wireless access services. In Japan the 4.9GHz – 5.0GHz band will be used after 2007 while the 5.47GHz – 5.725GHz band is also being considered for future use. The first one will require a license for BS deployment and will support 5MHz, 10MHz and 20MHz bandwidths, while the second one will possibly not require a license and would support 20MHz bandwidths.

The North American market is indicating some interest in deploying WiMAX in the 4.9GHz broad-spectrum public-safety band.

There is even some interest in using lower frequency bands such as the licensed 800MHz and the unlicensed 915MHz ISM bands for WiMAX and similar types of services and deployments.

The WiMAX standard is set to bring the long-awaited spectral efficiency and throughput to meet users' needs for combined mobility, voice services and high data rates. It will enable access for more users due to its non-line-of-sight capability, lower deployment costs, wide range capability and penetration into the mass consumer market with lower CPE costs as a result of standardization and interoperability.

Needless to say, it is the clear path to broadband mobility and will form the basis of "4G," offering a true freedom of mobility.

For more information

More information on the IEEE802.16 standard for broadband wireless access and the WiMAX Forum is available at www.wimaxforum.org and www.ieee802.org/16.

For more information on Fujitsu's broadband wireless SoC, please address e-mail to inquiry.bwa@fma.fujitsu.com.