

WiMAX 802.16-2004 SoC

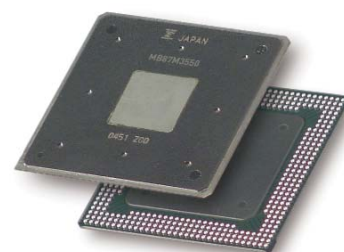
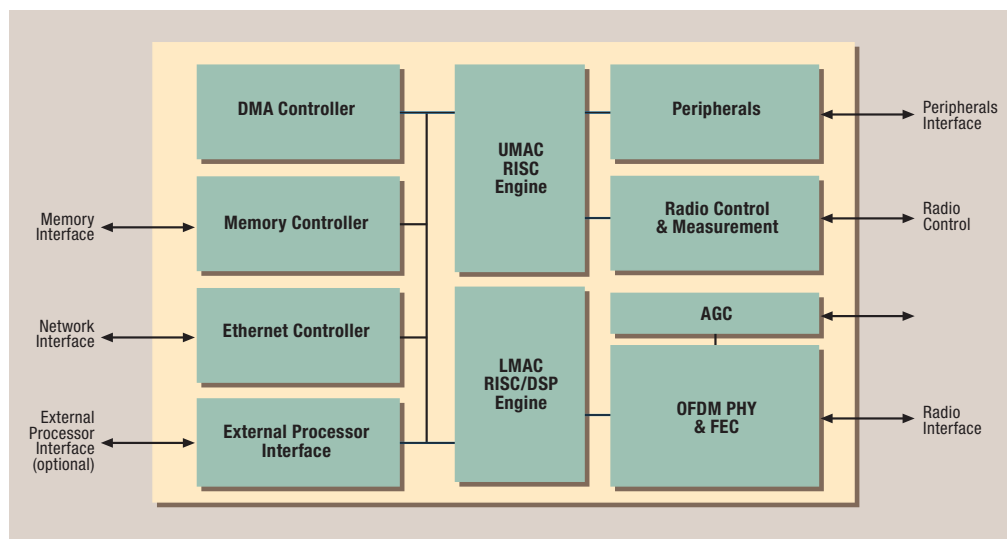

A simplified block diagram of the Fujitsu WiMAX SoC, MB87M3550, shows the dual processors and main hardware blocks that implement a complete PHY-to-MAC wireless MAN solution.

Description

Fujitsu has developed a cost-effective, fully integrated MAC and PHY mixed signal baseband processor for broadband wireless access applications. This SoC is designed to support frequencies ranging from 2 to 11GHz in both licensed and licence-exempt bands. It supports all available bandwidths from 1.75MHz to 20MHz. The Fujitsu WiMAX™ SoC can be configured to be used in both base-station and subscriber-station applications.

Two Fujitsu WiMAX SoCs work together to implement full-duplex FDD applications. The SoC can also work with an external processor to enhance performance in demanding base-station applications.

Highly efficient adaptive modulation schemes, including 64QAM, 16QAM, QPSK and BPSK, are supported by this SoC. Uplink sub-channelisation is also supported as defined in the standard. Performance enhancement can be realised with the dual RISC engines embedded into the SoC. These two processors not only easily handle the essential functions required by the WiMAX specification, but also allow additional headroom to handle user-application software.

Features

- Fully compliant with IEEE 802.16-2004 standard
- Supports both subscriber station and base station for TDD or FDD applications
- Integrated 256 OFDM PHY with 64QAM, 16QAM and QPSK modulation
- Uplink sub-channelisation
- Flexible baseband interface with integrated high-performance ADC and DAC
- Automatic Frequency Control (AFC) with integrated DAC
- Dynamic Frequency Selection (DFS) with integrated ADC
- Integrated ADC for transmit and receive power measurements
- Security implementation using DES, AES, CCM encryption/decryption
- Dual RISC processors for implementing upper & lower layer MAC
- Integrated memory controller and DMA controller
- Integrated Ethernet engine for network interface
- Rich set of integrated peripherals and RF control
- Programmable AGC to support broad range of RF attenuation

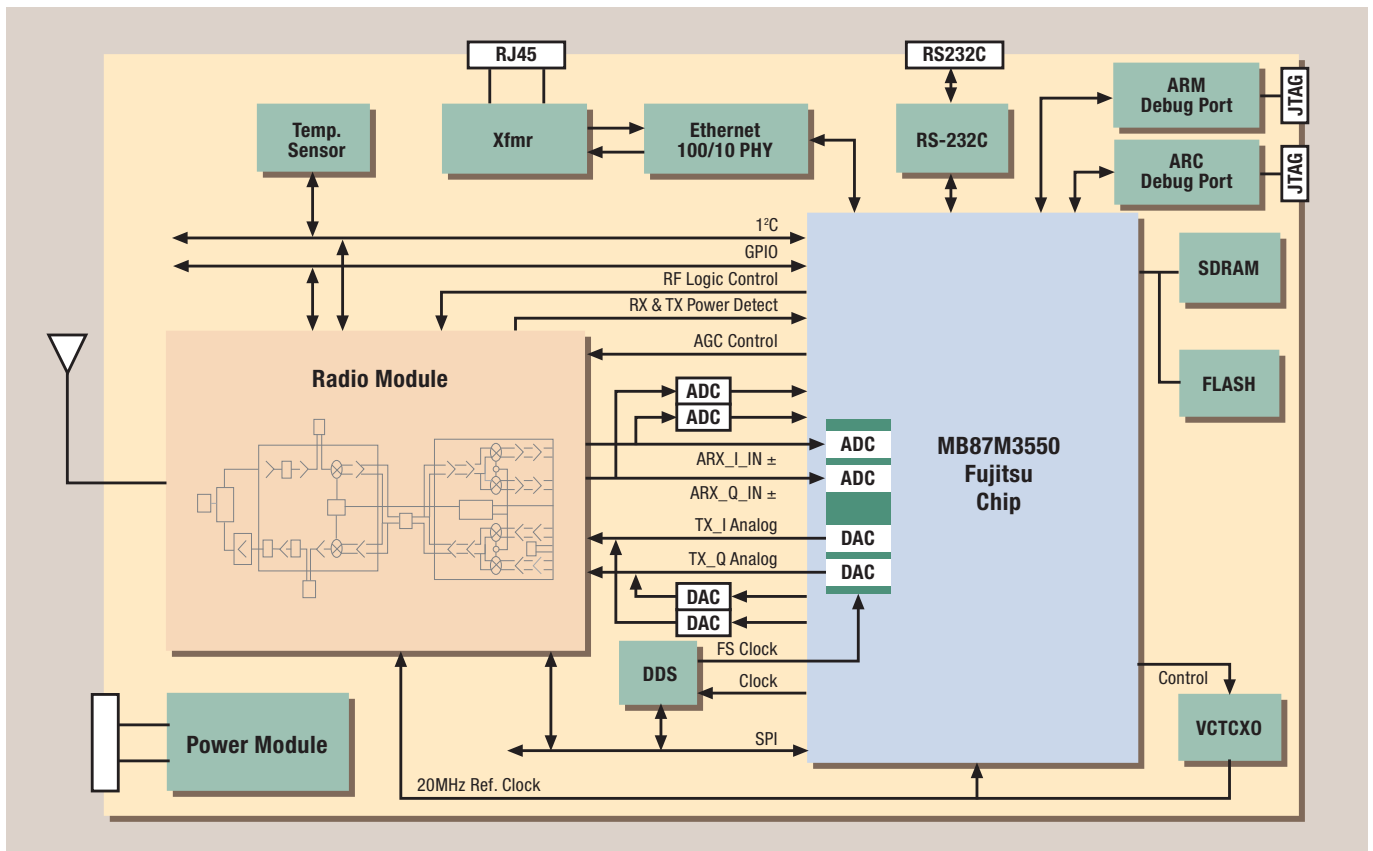

TDD or HDX FDD Reference Board Evaluation System.

Applications

- BWA systems compliant with fixed WiMAX specifications
 - Low-cost subscriber stations
 - Enterprise CPEs
 - Base stations
- 2 to 11GHz licensed and licence-exempt bands
- Suitable for licensed frequency bands at 2.5, 3.5, 3.6 or 5.6GHz
- Half-FDD/Full-FDD or TDD applications

Reference design

A complete reference design is available. The system includes all the required software & hardware for a cost-effective system solution. The Fujitsu 802.16 platform enables a BWA platform for subscriber stations or base stations with the following features:

- Compliant with IEEE 802.16-2004 standard specification
- MAC portability to different RTOS

- MAC security sub-layer for subscriber station authentication and data encryption
- Multiple service class support to differentiate service quality
- Dynamic service management to activate the service class when needed

Certification and compliance

Fujitsu has designed the WiMAX chip to comply with the IEEE 802.16-2004 standard.

Systems available on the market and based on this SoC have been successfully certified by the WiMAX Forum®.

<http://www.fujitsu.com/emea/services/microelectronics/networking>
<http://www.fujitsu.com/emea/services/microelectronics/wimax>

ASK FUJITSU MICROELECTRONICS EUROPE

Contact us on +49(0) 61 03 69 00 or visit
<http://emea.fujitsu.com/microelectronics>