

# MB87Q2091-DK Development Kit for MB87Q2091 10G Ethernet LAN-PHY mapper

## Description

The MB87Q2091-DK provides a quick and easy means to become familiar with the MB87Q2091 10G Ethernet LAN-PHY Mapper in its multiple configuration modes. Since the MB87Q2091 is generally used in conjunction with a 10Gbit/s FEC device for DWDM and long-haul applications, the IXF30009 10G FEC device from Cortina Systems, Inc<sup>®</sup> is included on the evaluation board. Software to configure both devices via a PC, is part of the development kit.



Reference design for 10 Gb Ethernet mapping applications.

Performance and network properties of the MB87Q2091 can be tested by connecting the board directly to SONET/SDH, OTN or 10GbE LAN/WAN-PHY test units.

The MB87Q2091-DK board also serves as a reference design for 10GE mapping applications using the MB87Q2091, in particular for providing guidance on clock and timing design as well as lay-out for high-speed signals.

## Interfaces

The MB87Q2091-DK board supports all interfaces required to test the transmission and programming aspects of the MB87Q2091:

- Four XFP cages providing direct, glueless access to the four MB87Q2091 XFI interfaces
- MB87Q2091 SFI-4.1 port No. 2 connection to either:
  - XFP cage via a SERDES device
  - MSA300 connector, which can be used to connect to Cortina<sup>™</sup> XEK8100x Evaluation System Kit components or an MSA-compatible 10G transponder
- One 76-pin MICTOR connector providing direct access to both MB87Q2091 SFI-5s interfaces
- Internally on the board, the MB87Q2091 is connected to the Cortina<sup>™</sup> IXF30009 via the remaining two SFI-4.1 interfaces

## Features

The MB87Q2091-DK contains the following elements:

- Driver software to control the configuration of the MB87Q2091 and Cortina<sup>™</sup> IXF30009 devices from a PC connected to the evaluation board
- Evaluation board with:
  - One MB87Q2091
  - One Cortina<sup>™</sup> IXF30009
  - Four on-board frequency dividers/multipliers that can be programmed via DIP switches
  - Four on-board, dual-output VCOs with frequencies that can be programmed via DIP switches
  - Four on-board, dual-output crystal oscillators with frequencies that can be programmed via DIP switches
  - Access via SMB connectors to all clock interfaces and on-board oscillators, VCOs and frequency multipliers/dividers allowing a high level of flexibility with regard to supported timing options and frequencies
  - One RJ45 connector providing 100BASE-TX LAN access to the on-board microcontroller
  - One RJ45 connector providing RS-232 access to the on-board microcontroller
  - A PowerQuickII<sup>®</sup> microcontroller complex based on Motorola's<sup>®</sup> 8270 processor with associated RAM and double E<sup>2</sup>PROM
  - On-board power converters that can be driven from a single power supply operating at 5V/12A via a banana-plug interface

**Applications**

The MB87Q2091-DK evaluation can board be used to test the numerous mapping modes that are supported by the MB87Q2091 in a network environment.

Moreover, the board can be used to test customer-defined device settings in combination with test equipment or other systems. This includes the use of rate control, flow control and trapping/insertion of Ethernet OA&M and/or management frames.

Below are some examples of signal mappings/conversions that can be tested:

- A 10GBASE-R LAN-PHY signal to a 10GBASE-W WAN-PHY signal
- A 10GBASE-R LAN-PHY signal converted to a standard G.709 OTM-0.2 signal by means of GFP-F encapsulation directly or via VC4-64c in the OPU-2 container
- A 10GBASE-R LAN-PHY signal converted to an overclocked OTM-0.2 signal by direct writing into the OPU-2 payload space

**AimValley**

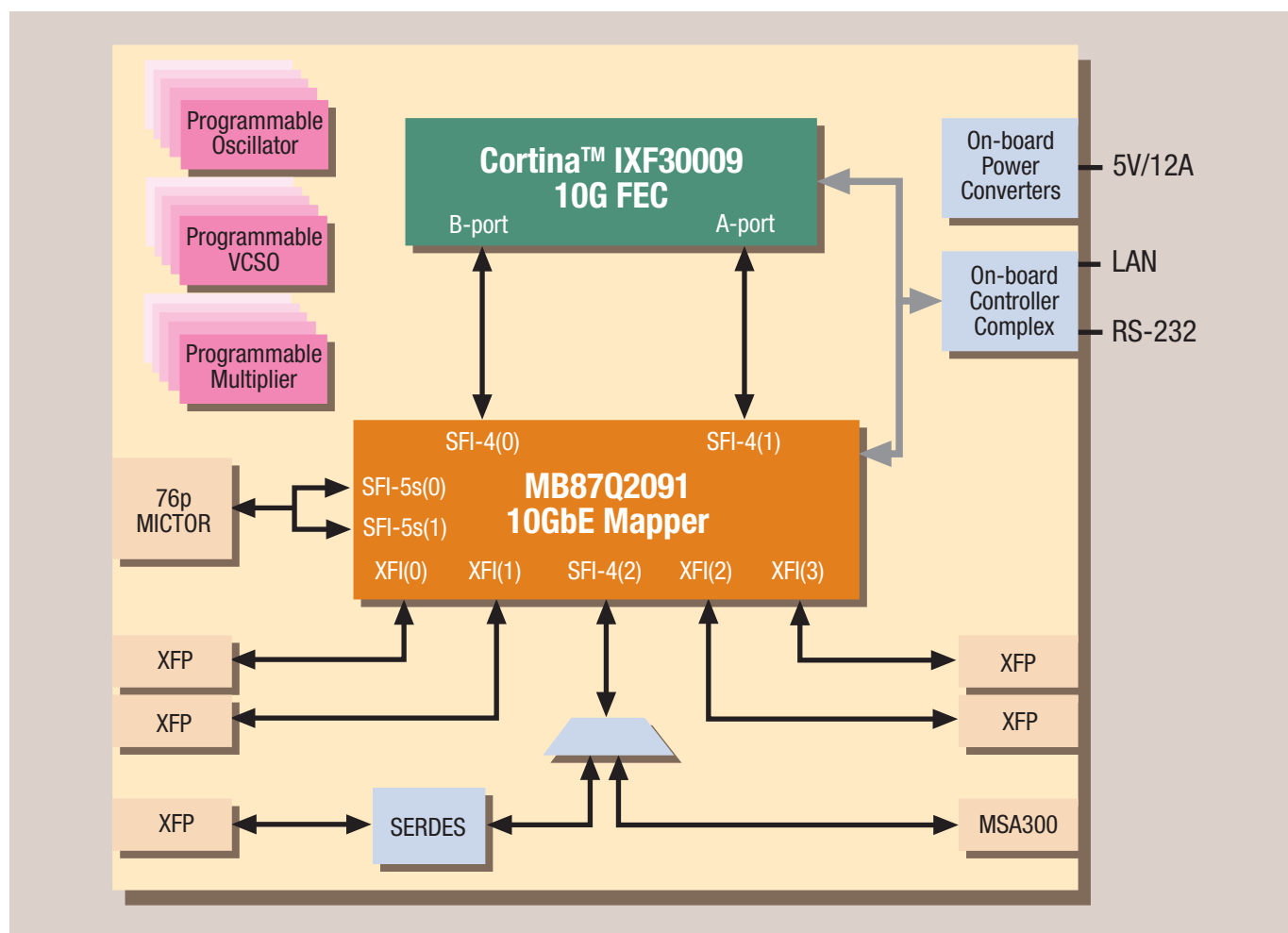

Block Diagram of MB87Q2091-DK evaluation board.

**ASK FUJITSU**

Contact us on +49(0) 61 03 69 00 or visit  
<http://emea.fujitsu.com/microelectronics>