

QAM DEMODULATOR

for cable receivers of Digital TV

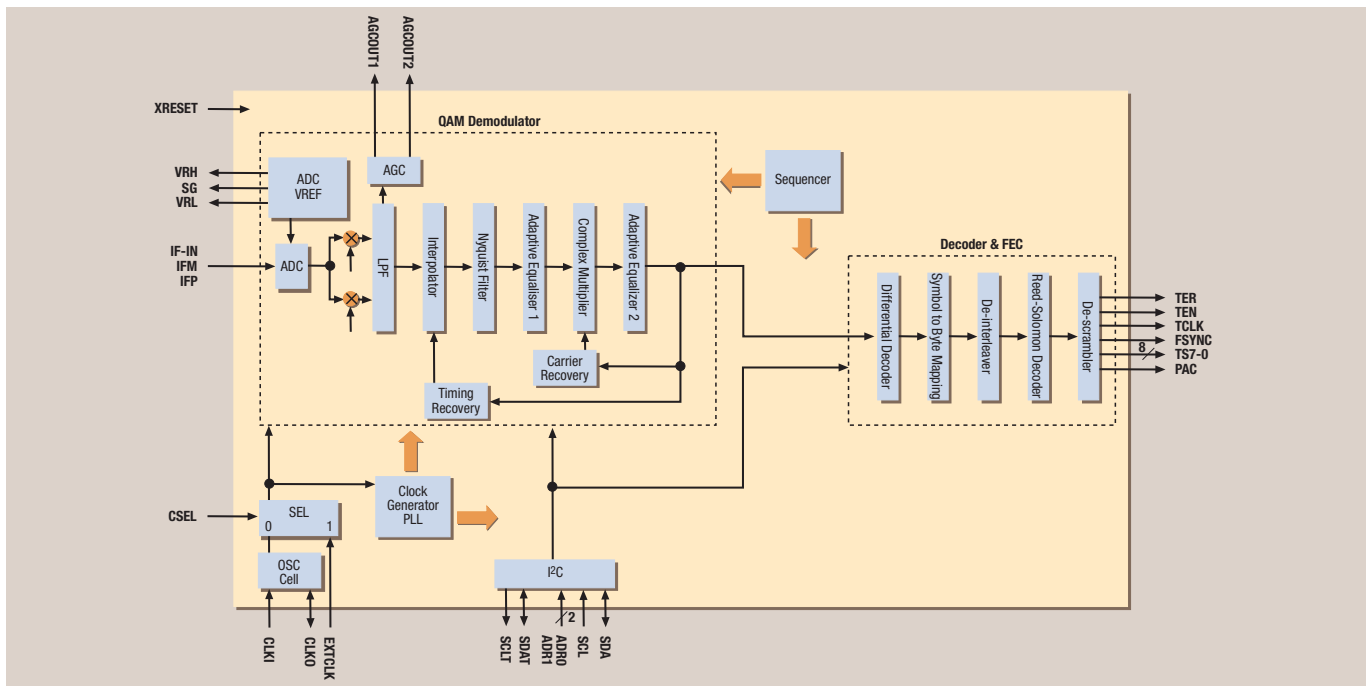

MB86668 block diagram.

Description

The MB86668 is a QAM demodulator of digital video broadcasting for cable systems. All functions necessary for receiving DVB-C signals (QAM demodulator and FEC) are implemented. The MB86668 has a new architecture, which was developed by Fujitsu, enabling STBs to be manufactured at low cost.

The MB86668 is a perfect solution for all cable applications, because of its low power consumption, small package size (LQFP48) and short bill of material. The NIM-like evaluation board and the drivers make a short design time possible. The software drivers are also included in the digital TV software of the SmartMPEG family, which allows a fast implementation of Free-to-Air zapping applications up to complex PVR applications.

Typical applications

- Cable set-top boxes
- Personal video recorder for cable reception
- Head-end equipment for cable reception
- Network Interface Modules (NIM) for cable reception

Features

- DVB-C (ETS300-429) and ITU-T J83 annex A compatible

- Input IF frequency: 36.000MHz, 36.125MHz, 36.150MHz, 36.167MHz
- Input IF level: 1.0Vp-p (Balanced)
- 16QAM, 32QAM, 64QAM, 128QAM and 256QAM demodulator
- Symbol rates: 2.200Mbaud to 6.957Mbaud
- Carrier frequency capture range: ± 150 kHz
- Integrated adaptive equaliser (Decision Feedback Equaliser)
- Differential decoding and mapping
- Forward Error Correction (FEC) decoder
- Parallel and serial transport stream interface
- RF-AGC and IF-AGC
- Spectrum inversion automatic detection
- Built-in carrier frequency offset monitor (via I²C bus interface)
- Built-in symbol timing offset monitor (via I²C bus interface)
- C/N and BER monitoring function (via I²C bus interface)
- Supply voltage : +3.3V, +1.8V
- Power consumption: typ 250 mW
- Package: LQFP-48
- Operating temperature range: 0 to +70°C

ASK FUJITSU MICROELECTRONICS EUROPE

Contact us on +49(0) 61 03 69 00 or visit
<http://emea.fujitsu.com/microelectronics>