

MB86H55/MB86H56

Ultra low power full HD H.264 CODECS

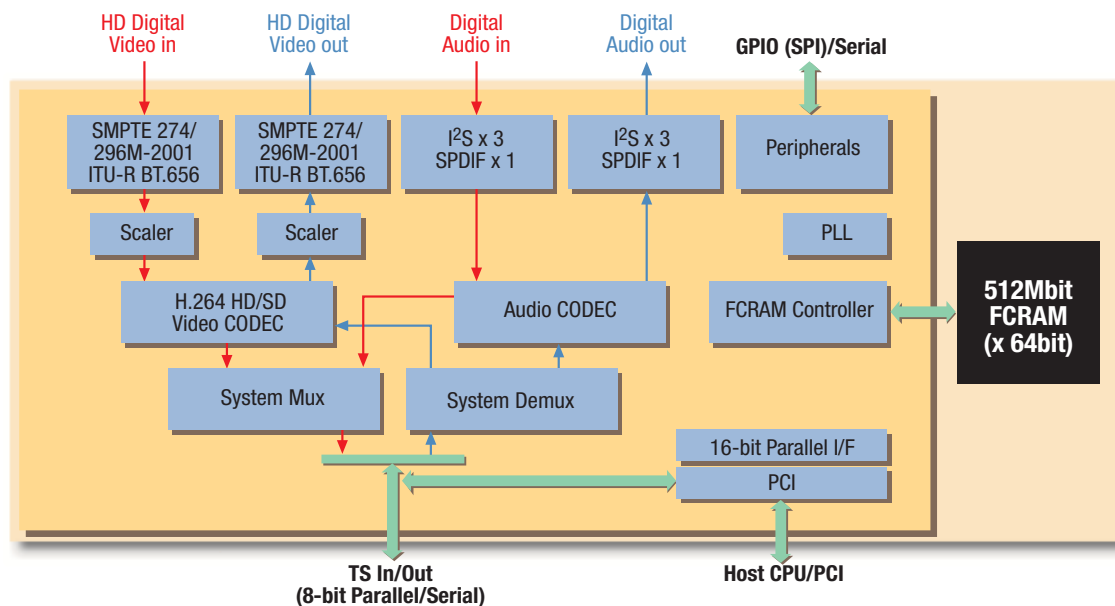

MB86H55/MB86H56 Codec block diagram.

Description

The Fujitsu MB86H55 and MB86H56 can compress and decompress full High-Definition (HD) video (1920 dots x 1080 lines) in the H.264 format in real-time. The two products feature power consumption of only 500mW during Full HD encoding including the in-package memory, an industry-leading level for low power consumption. In addition, MB86H56 offers processing of Full HD video at 60p, to improve further picture quality.

These two products have in-package memory to offer a small package size of 15mm x 15mm, thus making it ideal to record, play and transmit superior picture quality HD video on portable devices such as digital camcorders, as well as on home networked appliances, commercial broadcast equipment, and security cameras.

Applications

- Digital video camera
- Security camera
- Home network
- Disc recorder

Features

- **Small form-factor, low power consumption necessary for portable devices.** Both new products contain one 512M bit in-package memory. Due to the reduction in the number of memory chips, as well as the usage of 65nm process technology, the power consumption during Full HD encoding, including the in-package memory, is reduced to 500mW (at 60i). Also, it is provided in a small form-factor, 15 x 15mm package.
- **Processing at 60p further improves picture quality (MB86H56).** The existing CODEC product, MB86H51, processes video at 30 frames per second (60i); while the new

MB86H56 doubles this to 60 frames per second, 60p, to boost picture quality.

- **Both devices feature embedded Up/Down scaler.** Both products have an embedded scaler for expansion or reduction of the picture. In units of 16 bit x 32 lines, pictures can be expanded by a maximum of 6 times or reduced to 1/6.
- **Improved connectivity to peripheral devices.** Both products contain many interfaces for improved connectivity. There is a 16 bit parallel interface and a TS interface as the video stream interface. In addition, there is a serial interface in which a reduction of pins for host interface is possible, as well as a PCI interface for connecting a PC or a recorder. Connection to external ROM is also possible, thus realising high-speed boot for products that feature this devices.

Specifications		
Video	Profile	MB86H55: H.264 high profile / level 4.0 Half-duplex Codec MB86H56: H.264 high profile / level 4.2*1 Half-duplex Codec
	Resolution	1920 x 1080 x 60p/50p (MB86H56 only), 1920 x 1080 x 60i/50i/30p/24p, 1440 x 1080 x 60i/50i/30p/24p, 1280 x 720 x 60p/50p, 720 x 480 x 60i, 720 x 576 x 50i Up/Down scaler embedded
	Bit Rate	MB86H55: 24Mbps (max.), MB86H56: 30Mbps (max.)
	Interface	SMPTE 274M/SMPTE296M-2001, ITU-R BT.656, External sync mode (H/V/F + 16-bit data)
Audio	Format	Dolby® Digital (AC-3)*2, MPEG-2/4 AAC (LC profile), MPEG-1 Audio Layer 2, Linear PCM
	Channels	Max. 5.1ch*3
	Interface	I ² S, S/PDIF
System	Format	ISO/IEC13818-1 + Amd3 (MPEG-2 TS), Video/Audio ES output
	Interface	8-bit parallel, Serial, PCI
Host Interface	General 16-bit parallel, Serial, PCI	
Peripheral I/O	SPI	
Input Clock Frequency	27MHz	
Operating Frequency	MB86H55: 108MHz (internal memory interface only: 135MHz)	
	MB86H56: 189MHz (internal memory interface only: 189MHz)	
Power Consumption (including memory)	MB86H55: 500mW (typ., 1.2V, 1920x1080x60i at encoding)	
	MB86H56: 850mW (typ., 1.2V, 1920x1080x60p at encoding)	
Package	FBGA 650pin 15mm square SiP (Ball pitch 0.5mm)	
Memory	512Mbit FCRAM x 1	

*1 Support up to a maximum of 30Mbps bit rate.

*2 Dolby is a registered trademark of Dolby Laboratories.

*3 Number of channels depend on audio format.

ASK FUJITSU MICROELECTRONICS EUROPE

Contact us on +49(0) 61 03 69 00 or visit
<http://emea.fujitsu.com/microelectronics>