

HIGH PERFORMANCE

Digital to analogue converters

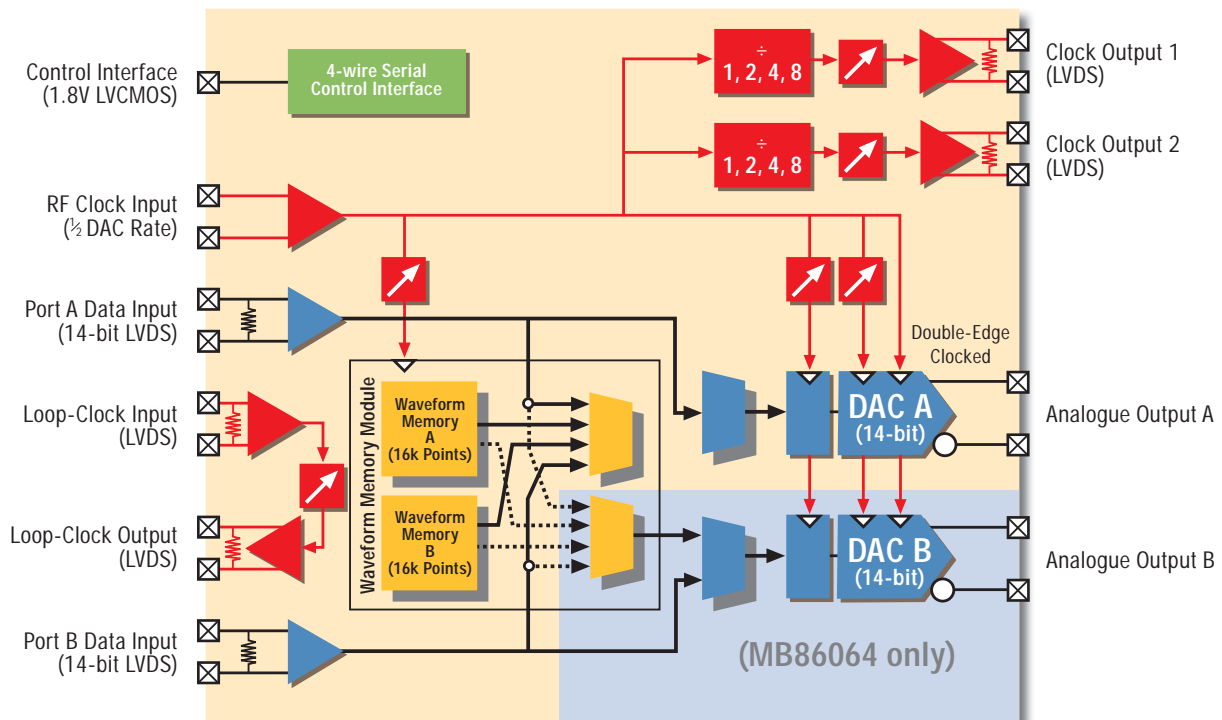

MB86064/5 Functional Block Diagram.

Description

Fujitsu's digital to analogue converters provide market leading performance to deliver system power, cost and risk savings.

- MB86064 Dual 14-bit 1.0 GSa/s
- MB86065 Single 14-bit 1.3 GSa/s

The MB86064 is ideally suited to radio applications demanding dual-transmit or transmit with diversity high direct-IF architectures. Alternatively the MB86065 meets the needs of single transmit or modular multi-sector designs, whilst supporting conversion rates up to 1.3GSa/s. This enables even higher generating frequencies combined with wider spurious-free generating regions.

Both devices feature the market's shortest propagation delay for 1GSa/s DACs, which is very relevant to control applications requiring low latency. Full product support and documentation includes datasheets, customer development kits and application notes.

Applications

- Radio communications & test systems, including TDMA, CDMA, UMTS, TD-SCDMA, LTE, WiMAX and UWB
- Low latency digital control
- Medical & test instrumentation

Features

- High frequency direct-IF multi-carrier generation
- 74dBc ACLR for 4x UMTS carriers at 276MHz
- Avoids the hardware and firmware overhead of gain and phase correction in IQ and direct conversion architectures
- Supports multiple, including non-contiguous, narrow & wide band signal generation
- Pin compatible single- and dual-channel devices support common platform designs
- LVDS input data interface with proprietary automatic Loop-Clock synchronisation
- Integrated waveform memory module (WMM)
- 12 x 12mm EFBGA package

FACTSHEET
MB86064 & MB86065

Multi-Carrier Made Easy

High direct-IF architectures provide the optimum solution for implementing truly versatile radio transmit systems. Key benefits include the high IF making subsequent up-conversion easier and from simple frequency planning a wide, clear generating band to support digital pre-distortion. Furthermore, any need to correct gain and phase errors, associated with IQ and direct conversion techniques, is avoided thus minimising complexity and ensuring the system is stable over its operating life. Even more valuable is the superior handling of non-contiguous carriers in multi-carrier systems.

Fujitsu's system partitioning rationale, when using the MB86064/5 DACs, makes extensive use of the latest digital process technology through implementing pre-processing in the data generating FPGA. This approach supports maximum flexibility for design re-use by adopting a fixed analogue element, which will have been subject to extensive characterisation. Design changes and updates to the digital pre-processing can then be more readily made to address new product derivatives or take advantage of new generations of FPGA technology.

System Integration

Robust data interfacing to compatible FPGAs and ASICs is assured by the proprietary Loop-Clock. No calibration is required during production or over operating life, avoiding otherwise potentially expensive total system costs.

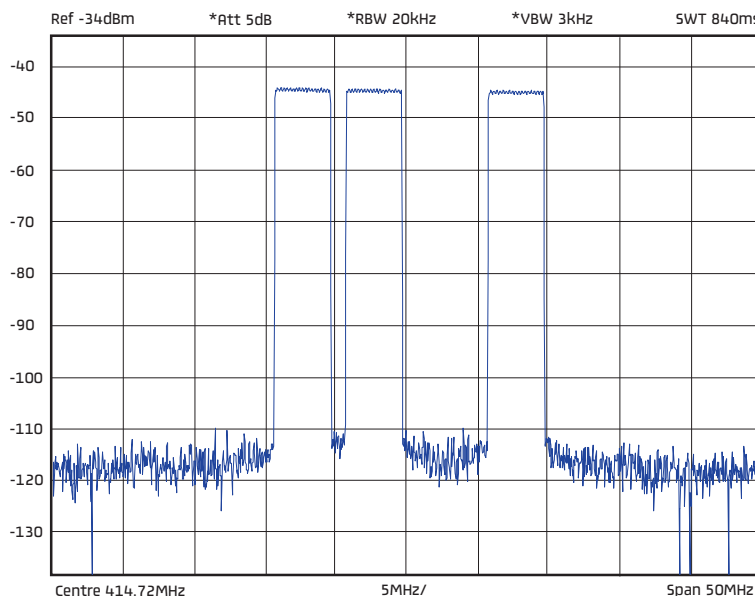

3 Non-contiguous Carrier Performance at 414MHz High Direct-IF.



Customer Development Kit.

Development Kits

Comprehensive customer development kits are available for both devices:

- DK86064-2
- DK86065-2

The kit includes everything needed to minimise the time to get started, including evaluation board, PC-USB interface and PC software utility.

Application Notes

- WMM 32k Point Vector Mode
- Xilinx Virtex-5 FPGA Interface
- Power / duty cycle trade-off
- Op-Amp output circuit
- Varying full-scale output current

Part Numbers

- MB86064PB-GE1
- MB86065PB-GE1

Both devices are RoHS 6/6 compliant and available now.

<http://www.fujitsu.com/emea/services/microelectronics/dataconverters/>

ASK FUJITSU MICROELECTRONICS EUROPE

Contact us on +49(0) 61 03 69 00 or visit <http://emea.fujitsu.com/microelectronics>