

ARM1176 PROTOTYPING KIT significantly reducing SoC development time by around 50%

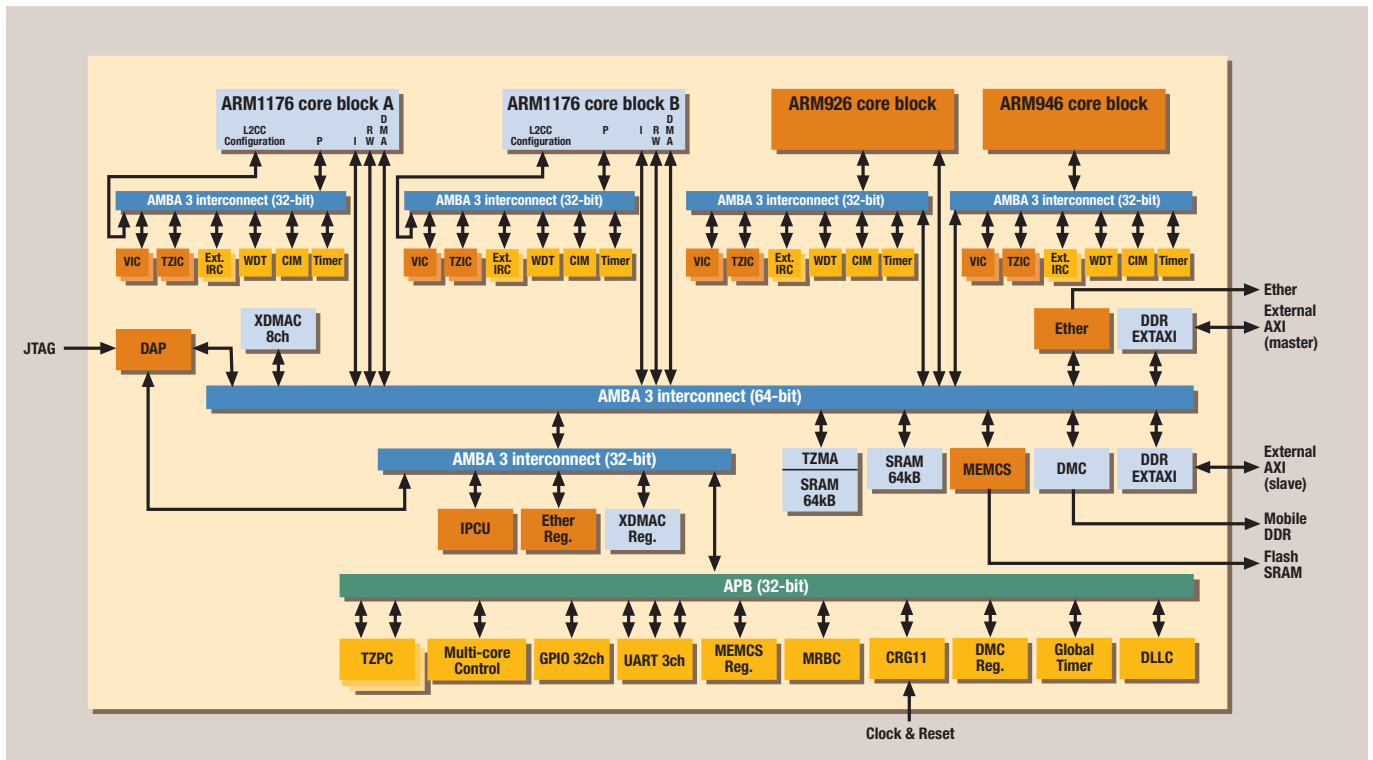

Block diagram of ARM1176 Prototyping Kit.

Description

This prototyping kit consists primarily of an evaluation board equipped with a 90nm platform chip incorporating four ARM® cores: 2 X ARM1176JZF-S, 1 X ARM926EJ-S and 1X ARM946E-S. The board also includes a Virtex 5 FPGA for loading user logic and for evaluation.

In addition to the platform chip and the FPGA (which contains a reference design) the design kit includes a sample program, a logical simulation model, and the manual. Since a dummy module (including the bus structure) is installed in the FPGA reference design, customers can develop their SoC with the ARM1176JZF-S simply by replacing it with their own module.

Therefore, prior to completion of the ARM1176-SoC, it is possible to evaluate the developed functional user logic and the driver, in order to improve the speed performance of the customer-developed SoC, resulting in a faster system-LSI design process.

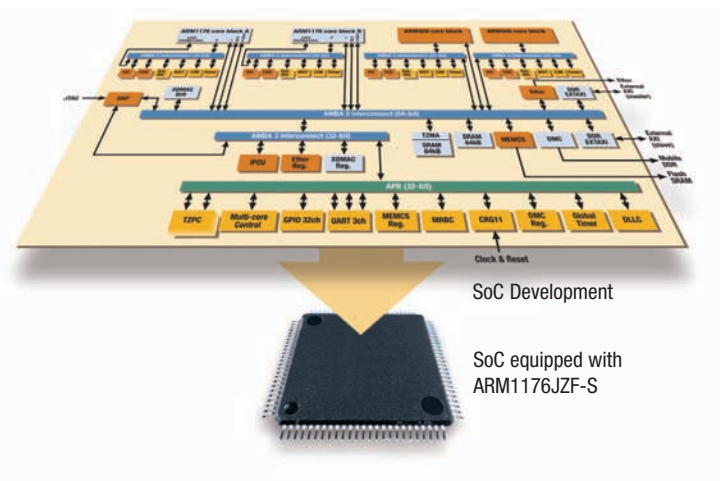

FACTSHEET
ARM1176 PROTOTYPING KIT

Features

Verification can be performed in near real conditions

Performance of the external AXI bus - which connects the evaluation LSI for ARM processors on the evaluation board with the FPGA loaded with the customer's logic circuit – was improved by a factor of 8 to 16 compared to previously available products. This makes it possible for customers to verify their own logic under conditions that closely resemble the resulting system LSI. Due to the fact that system LSIs for still images or video processing take a considerable amount of time to verify using logic simulation, practical testing that resembles the actual system LSI environment can shorten the development lead time.

FPGA reference design helps shorten LSI development lead time

Because the FPGA reference design includes dummy modules that comply with industry-standard advanced microcontroller bus architecture (AMBA) (*3), customers can simply replace the dummy modules with their own modules to easily build a prototype design of a system LSI based on the ARM1176JZF-S.

Using this FPGA, customers can verify their custom logic and develop device drivers before the system LSI has been fabricated, thereby reducing the development lead time. The evaluation board is compatible with the HapsTrak specification of the prototyping board from Synplicity, with an expandable FPGA domain.

Key Specifications of the ARM1176 Prototyping Kit		
Evaluation Board	LSI	ARM processors evaluation LSI and FPGA
	External Bus	64-bit External AXI (*1) (DDR, max. 100MHz)
	Memory	Flash memory 32MB Mobile DDR SDRAM 128MB
	External Interface	Ethernet, UART, ICE
LSI used to evaluate ARM processor	Multi-core processor	ARM1176JZF-S (max. 500MHz), ARM926EJ-S (max. 400MHz), ARM946E-S (max. 400MHz)
	Process technology	CMOS 90nm
	Package	FCBGA (*2) 1156 (35 x 35mm)
	Power consumption	1.2W (ARM1176JZF-S: operating at 500MHz, typ.)
	Other	FPGA reference design, sample program, simulation model, user's manual

(*1) AXI:

Advanced eXtensible Interface. A high-speed bus conforming to ARM's AMBA 3.0 specification. Used as processor bus for ARM1176JZF-S

(*2) FCBGA:

A multi-pin package that includes flip-chip bonding technologies.

(*3) AMBA:

Advanced Microcontroller Bus Architecture. An industry standard SoC (System-on-Chip) on-chip Bus from ARM.

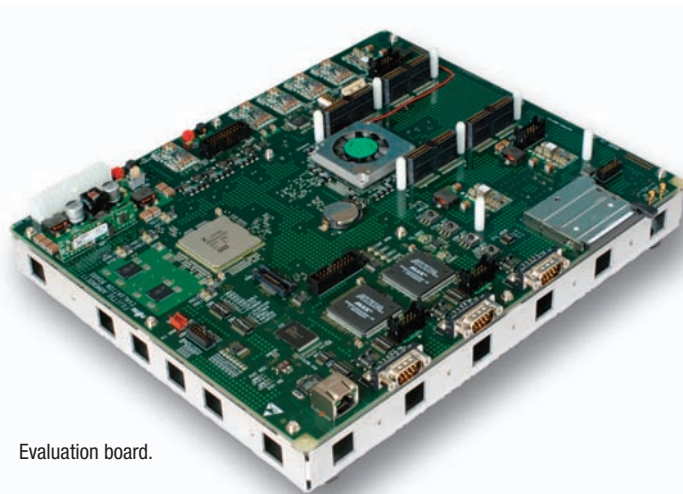

Evaluation board.



ARM, ARM Limited, ARM1176JZF-S, ARM926EJ-S, ARM946E-S and AMBA are registered trademarks or trademarks of ARM Limited. HapsTrak is a trademark of Synplicity, Inc. All other company or product names herein are the property of their respective owners. Information in this fact sheet is accurate at time of publication and is subject to change without prior notice.

ASK FUJITSU MICROELECTRONICS EUROPE

Contact us on +49 (0) 61 03 69 00 or visit <http://emea.fujitsu.com/microelectronics>