

MOBILE WiMAX 802.16e-2005 SoC

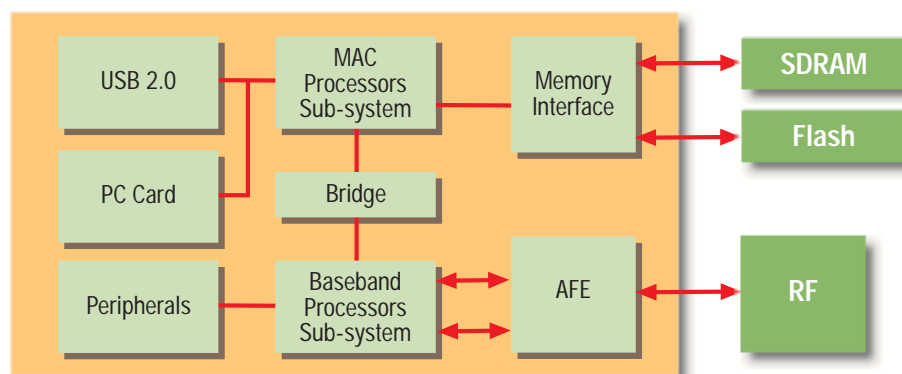

A simplified block diagram of Fujitsu's Mobile WiMAX SoC with highly integrated 1024 FFT OFDMA PHY and full MAC processors.

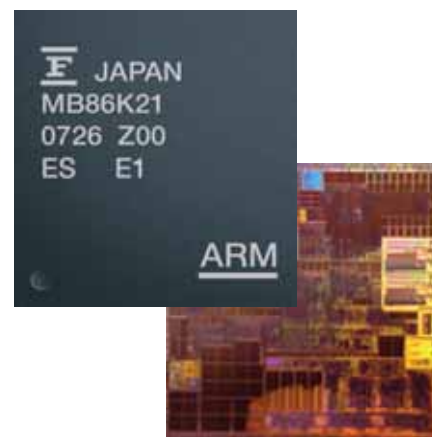

Description

To continue the progression from fixed to mobile, Fujitsu has developed a one-chip, highly integrated, MAC and PHY, mixed signal, baseband processor for mobile WiMAX™ applications.

The MB86K21 baseband SoC is designed to optimise power consumption using Fujitsu's 90nm with low-leakage process technology. The Fujitsu WiMAX SoC is fully compliant with the IEEE 802.16e-2005 Mobile WiMAX standard.

Features

- Implements all features required for Wave 2 Mobile WiMAX certification
- OFDMA PHY with TDD
- 512/1024 points FFT to support 5MHz and 10MHz channel bandwidth
- 64QAM (DL), 16QAM and QPSK modulation
 - Support of space time coding with 2-antenna matrix A/B (vertical encoding)
 - H-ARQ chase combining with CTC
 - AES encryption/decryption for 802.16 MAC security sub-layer
- Baseband analogue interface with integrated ADC and DAC
- Automatic Frequency Control (AFC) with integrated DAC
- Integrated ADC for transmit and receive power measurement
- RF attenuator control
 - Programmable AGC for supporting broad range of RF attenuators
 - RF control logic programs the Rx and Tx gain when the radio switches between receive and transmit

- Dual RISC processors for implementing upper & lower MAC
- Integrated memory controller and DMA controller
- Integrated peripherals
 - I²C interface
 - USB2.0 interface
 - Card bus interface
 - SPI interface to control external peripherals
 - Debug ports for embedded processors
- 90nm with low-leakage process technology
- FBGA Package

Applications

The Fujitsu Mobile WiMAX SoC suits several types of applications including:

- Mobile stations and terminals
- PC cards

Design kits available

- The reference design kit (RDK) with software and radio solution
- The System Development Kit (SDK) for evaluation and development of embedded applications



FACTSHEET
MB86K21 BASEBAND SoC

As the supplier of the first Fixed WiMAX System-on-Chip (SoC) based on the IEEE 802.16d-2004 standard, Fujitsu has been actively involved in WiMAX and IEEE 802.16 activities since 2003.



The Fujitsu Mobile WiMAX SoC MB86K21 uses Fujitsu's capability to integrate complex electronic devices, its extensive experience in mobile phone design and development, and its system knowledge and expertise for end-to-end WiMAX solutions.

Reference design

With the Fujitsu Mobile WiMAX PC-Card reference design kit (RDK), customers can easily meet the time-to-market demands of Wave 2 MIMO Mobile WiMAX-based terminals.

This PC card reference design kit with the CardBus interface is designed for OEMs, ODMs, and system manufacturers who will provide Mobile WiMAX products.

Along with the reference design hardware, Fujitsu delivers detailed design documents to help customers develop products. Fujitsu provides documents such as schematics and gerber files, as well as comprehensive design guidelines.

The Fujitsu RDK software package includes CardBus drivers based on Windows operating system. On top of the hardware interface driver, Fujitsu provides an API software layer for customers to develop custom application and graphic user interfaces.

Fujitsu offers the MAC software in binary code based on the mobile WiMAX standard and provides drivers, APIs, sample user application software and maintenance application software to help customers use the MB86K21 Mobile WiMAX SoC.

Fujitsu's maintenance software can measure air-traffic performance, noise level, error rates, transmitting and receiving powers, MAC management messages, connection IDs, as well as providing settings/readings for many useful parameters.

The System Development Kit enables customers to evaluate WiMAX using the MB86K21. With the SDK, the software development to integrate WiMAX into customer products and systems can be started in parallel with the hardware design.

As previously mentioned in the RDK section, the SDK comes with a similar set of software and tools.

Certification and compliance

Fujitsu has designed the WiMAX SoC to comply with the IEEE 802.16e-2005 standard.

Availability

Engineering samples of MB86K21, the RDK and SDK are available now. Systems using the Fujitsu Mobile WiMAX SoC will be submitted to the WiMAX Forum for certification. Fujitsu plans multiple SoC releases to match customers' product targets. The initial release - MB86K21 - is the first broadband SoC to deliver MIMO Wave 2 certification compliance. The second releases in 2008 and subsequent releases will support better performance, more features and can be tailored to different applications.

These 2nd and 3rd generation SoCs will cover functions such as full mobility, VoIP and multimedia applications over mobile appliances. Companion products such as WiMAX RF modules will be available with the SoCs.



<http://www.fujitsu.com/emea/services/microelectronics/networking>
<http://www.fujitsu.com/emea/services/microelectronics/wimax>

ASK FUJITSU MICROELECTRONICS EUROPE

Contact us on +49(0) 61 03 69 00 or visit
<http://emea.fujitsu.com/microelectronics>