

MB87M2181 SYSTEM-ON-CHIP

Ethernet over SDH/SONET

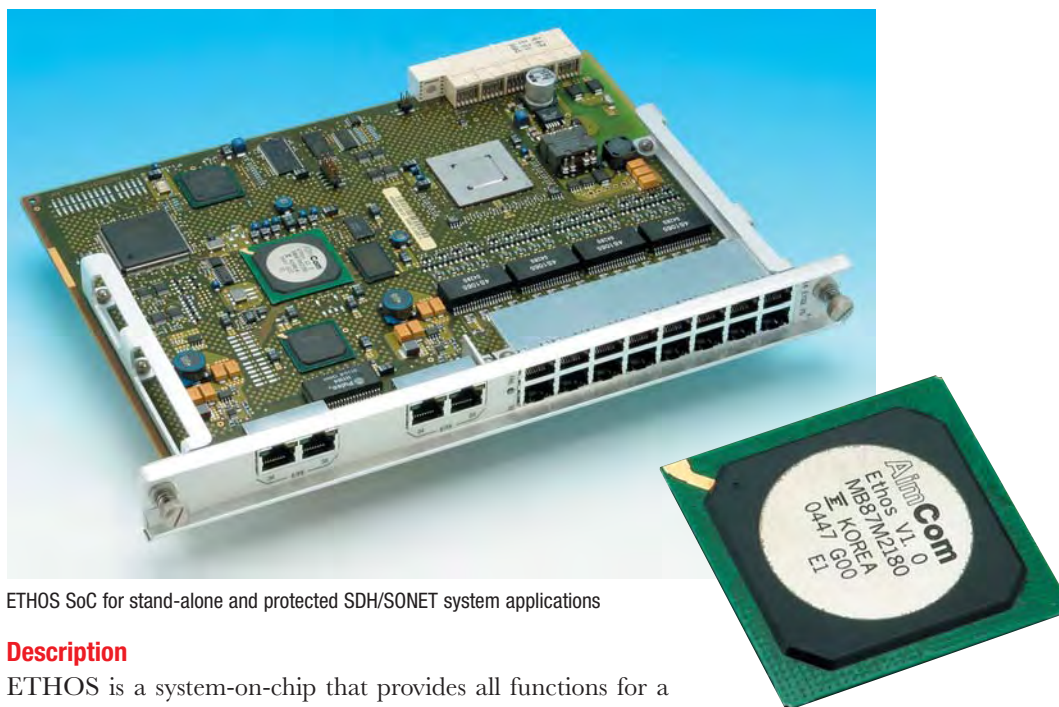

ETHOS SoC for stand-alone and protected SDH/SONET system applications

Description

ETHOS is a system-on-chip that provides all functions for a hybrid SDH/SONET and data multiplexer/mapper, and provides full-rate GbE transport over SDH/SONET.

Typical applications include SDH/SONET network terminator with Ethernet and PDH access interfaces at customer premises as well as SDH/SONET aggregation systems with DS1 or E1 interfaces or interface cards in telecom or datacom equipment.

Interfaces

- 2 x STM-1/OC-3, STM-4/OC-12 multi-rate line interfaces
- 2 x STM-1/OC-3 fixed-rate tributary interfaces
- Glueless interfaces to hot-pluggable SFP modules
- 4x E1/DS1
- 4x Gigabit Ethernet or Fast Ethernet
- Telecom bus, 19.44MHz, 8-bit interface
- 2MHz, 2Mbit and DS1 timing output

Features

- 19 x 19 AU-4, 57 x 57 STS-1 high order cross connect
- 14 x 14 VC-12/VT-1.5/VC-3 low order cross connect (VC-4 equivalents)

- Full support for SDH/SONET pointer processing, overhead termination and protection schemes
- Up to 4 virtual concatenation groups for flexible Ethernet transport
- Lower order groups supporting a total capacity of 9 VC-3s, 126
 - VC-12s or 126 VT-1.5s
 - VC-3-Xv (X=1..9)
 - VC-12-Xv (X=1..63)
 - VT1.5-Xv (X=1..63)
- Higher order groups supporting a total capacity of 8 VC-4s or 24 STS-1s
 - VC-4-Xv or STS-3c-Xv (X=1..8)
 - STS-1-Xv (X=1..24)
- Interface to external memory for up to 128msec differential delay compensation
- Low-latency and hitless LCAS (G.7042)
- GFP, LAPS and PPP mapping of Ethernet frames
- Jumbo frame support and flow control over 80km of 1000BASE-X fibre with optional external memory
- Ingress and egress rate controller per channel, from 0 up to 1000 Mbit/s, in steps of 100kbit/s

FACTSHEET
MB87M2181 SYSTEM-ON-CHIP

- Ethernet to Ethernet local cross connect with MAC frame insert/extract to CPU (Managed Ethernet NT or media converter applications)
- Flexible xMII interface supporting various PHY devices and MMI management interface
- Access to DCC overhead channels
- 32-bit interface to PowerPC CPU
- Completely integrated G.813 SEC / GR-1244 Stratum-3 network Element clock timing reference generation, selection and distribution functions from a single oscillator
- HDLC based In-band management channels (IMC) via P12 (2Mbit/s) or P11 (DS1)
- Integrated HDLC controller and internal packet memory for 4 DCC or IMC serial channels

Technology and Package

- 0.18µm CMOS technology
- 1.8V / 2.5V / 3.3V power supply
- 756-pin BGA
- Total power consumption < 5W

Applications

- Access equipment for Ethernet, Fast Ethernet, Gigabit Ethernet, E1 and DS1
- OC-12/STM-4 network termination
- Slide-in unit for E1/DS1 and Ethernet access in protected SDH/SONET ADM or MSPP
- Small SDH/SONET Add/Drop multiplexer

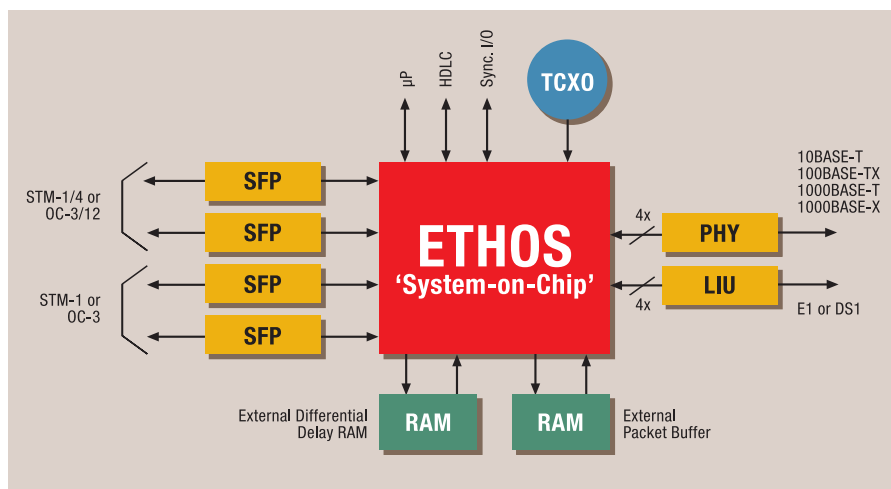

ETHOS used in stand-alone application.

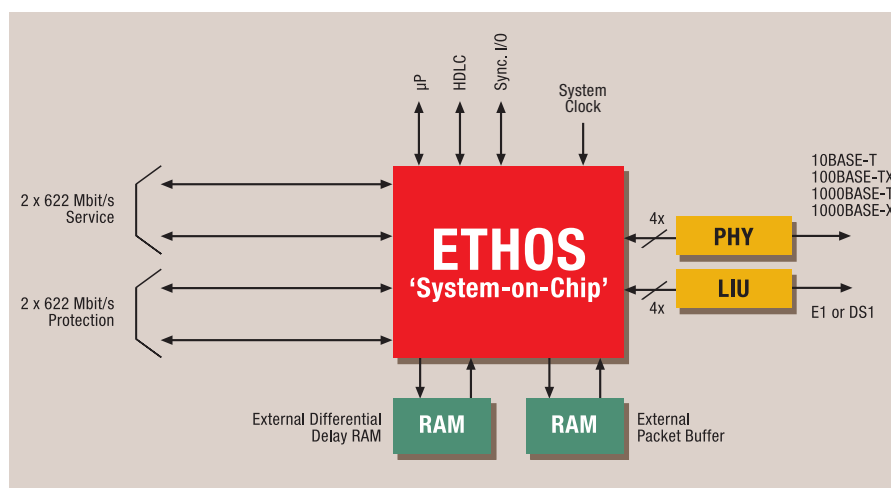

ETHOS used on a slide-in unit in a protected SDH/SONET system.

AimCom

www.aimcom.nl

AimCom BV is a privately owned semiconductor design company, providing building blocks for Next Generation Optical Networking solutions for delivery of cost-effective carrier-class SDH and Ethernet services. Together with its sister companies, AimSys and AimBridges, AimCom offers full-featured carrier-class solutions for metro and regional service providers.

ASK FUJITSU

Contact us on +49(0) 61 03 69 00 or visit
<http://emea.fujitsu.com/microelectronics>