

467/GDC Evaluation Board

Revision: PA3

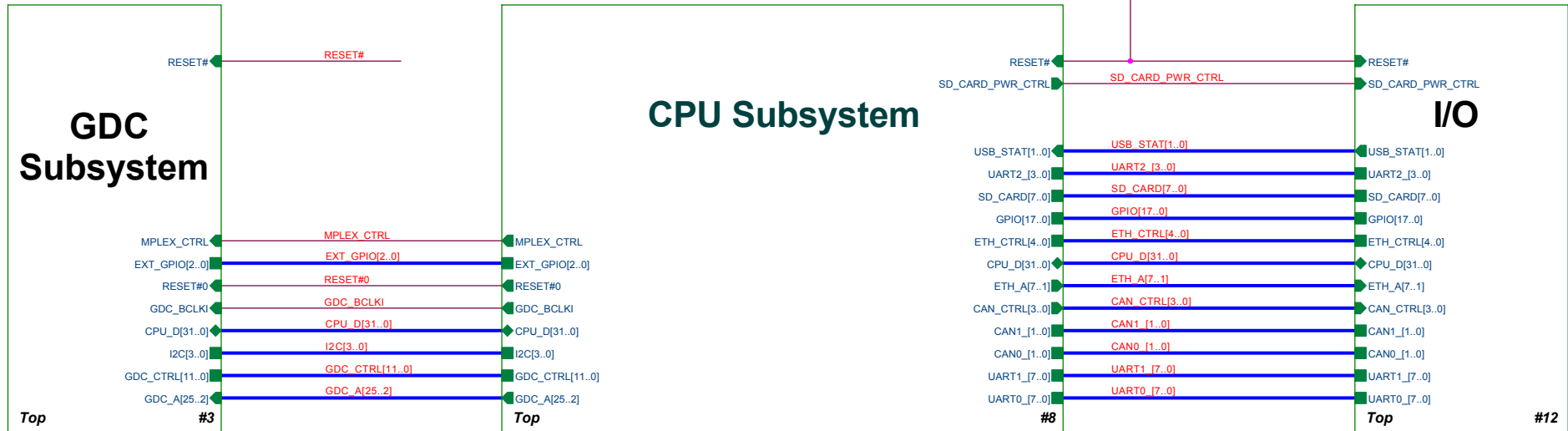
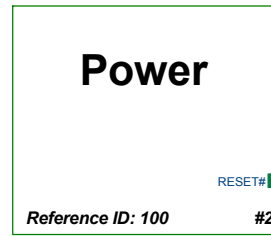

Device	Function	Write	Read
U480 SAA7113	composite video input	0x48	0x49
U400 SIL164	DVI transmitter #0	0x70	0x71
U401 SIL164	DVI transmitter #1	0x72	0x73

Hierarchy	Part References
+---#1 Lime Platform Top	
+---#2 Power	1xx
+---#3 Graphics Subsystem	2xx
+---#4 GDC Extension	3xx
+---#5 ---	
+---#6 Video I/O	4xx
+---#7 Video In	48x
+---#8 CPU Subsystem	
+---#9 CPU	5xx
+---#10 RAM	59x
+---#11 Flash	58x
+---#12 IO	
+---#13 Ethernet / USB	6xx
+---#14 CAN	7xx
+---#15 UART	8xx
+---#16 GPIO / SD Card	9xx

© mycable GmbH
Boeker Stieg 43
D-24613 Aukrug
Germany
www.mycable.de

Title: 467/GDC Evaluation Board

Size: A3	Document Number: 30420-001	Rev: PA3
----------	----------------------------	----------

Date: Saturday, September 29, 2007 Sheet 1 of 16

PCB Layout: see application notes in data sheet !

Place capacitors directly power input and output!

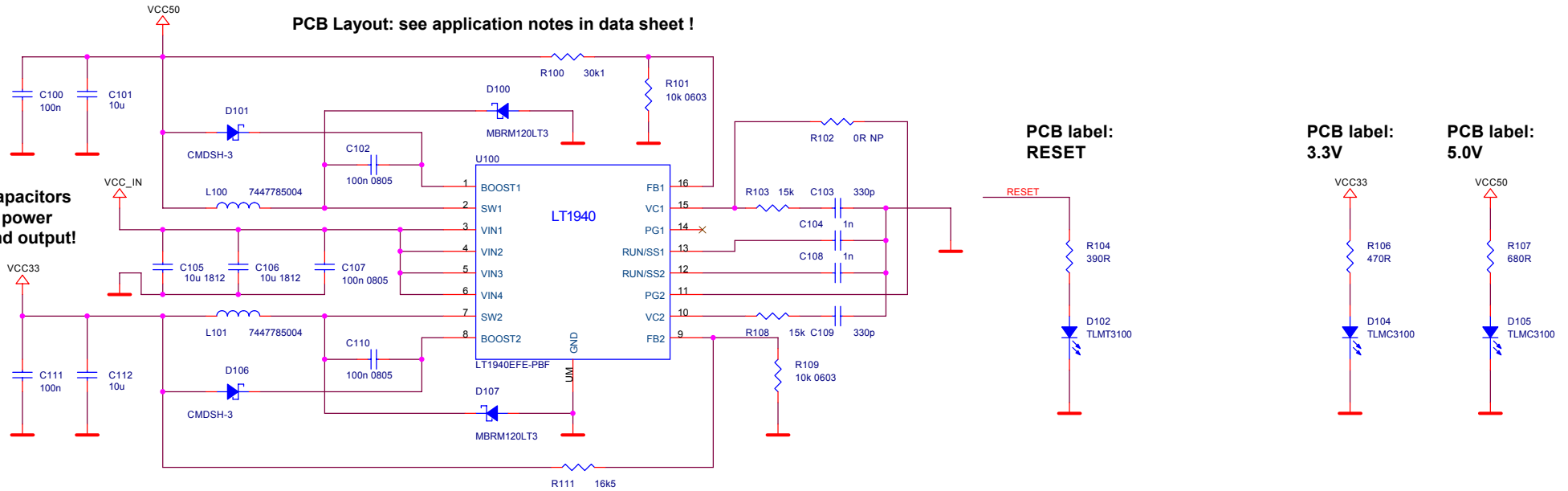

PCB label:
RESET

PCB label:
3.3V

PCB label:
5.0V

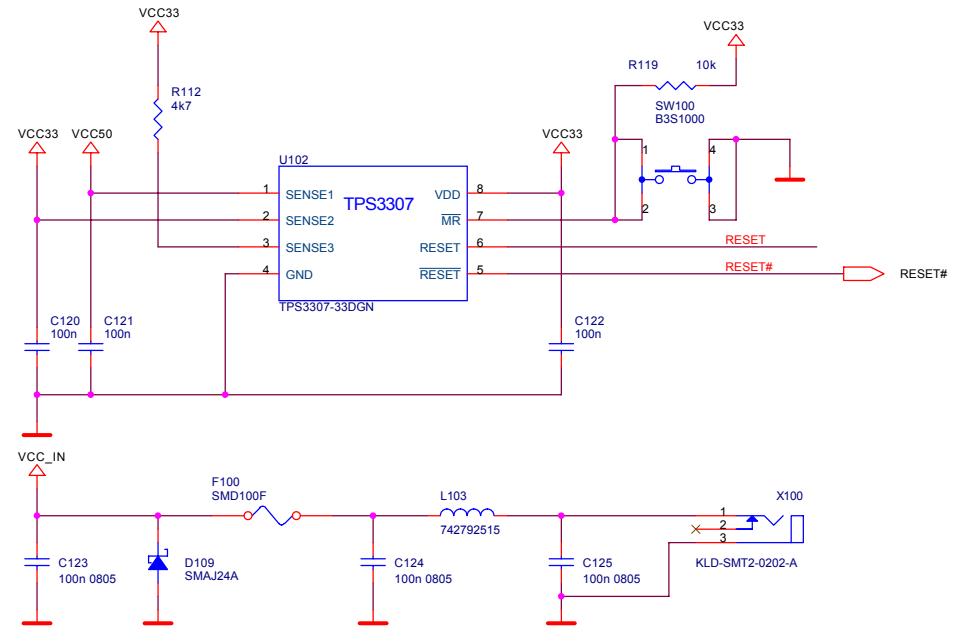

© mycable GmbH

Boeker Stieg 43
D-24613 Aukrug
Germany
www.mycable.de



Title
467/GDC Evaluation Board: Power

Size
A3 Document Number
30420-002

Rev
PA3

Date: Saturday, September 29, 2007 Sheet 2 of 16

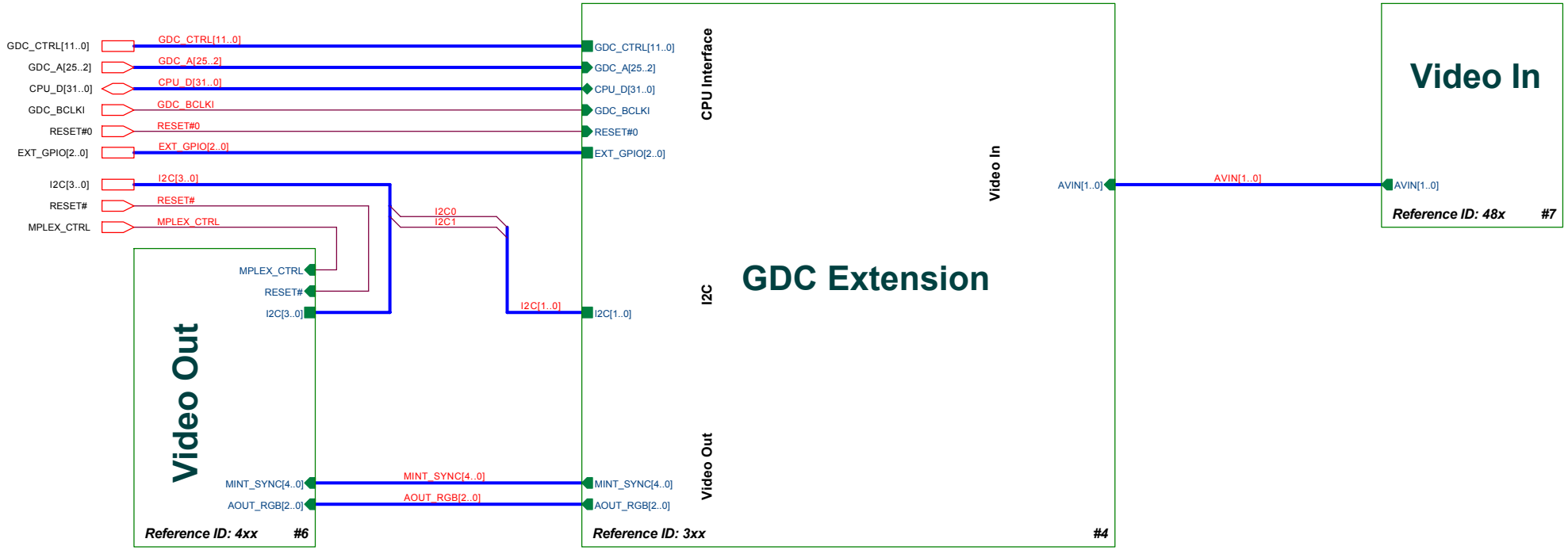

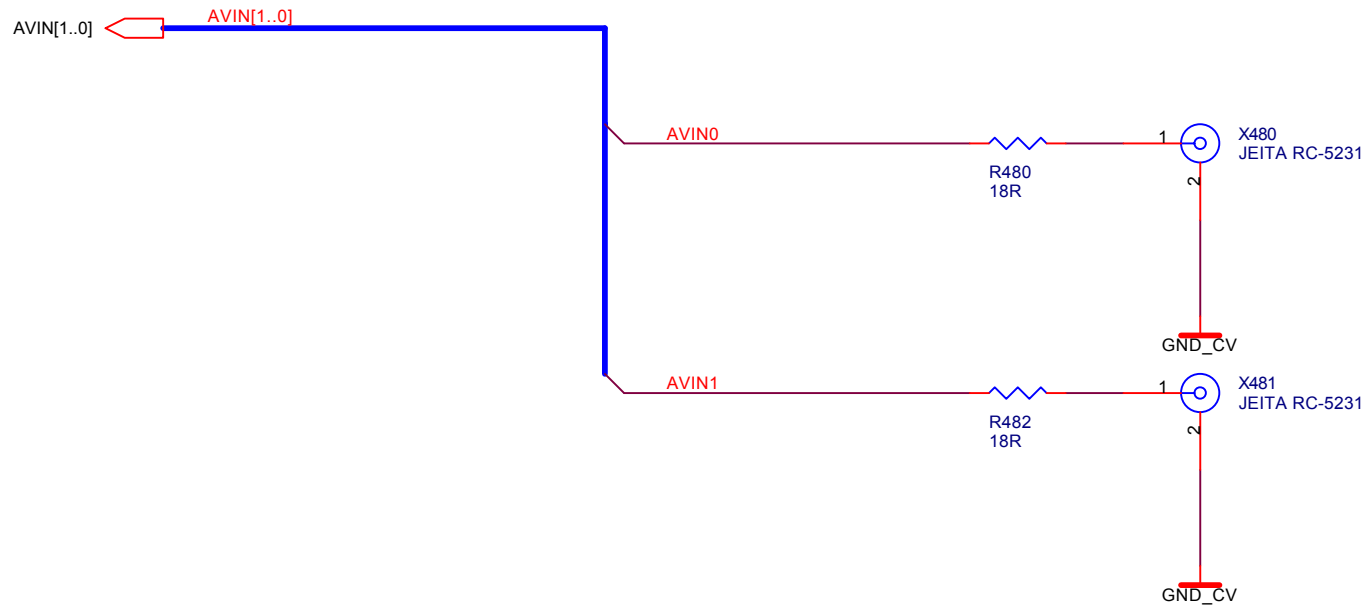

© mycable GmbH		
Boeker Stieg 43 D-24613 Aukrug Germany www.mycable.de		
		
Title 467/GDC Evaluation Board: GDC Subsystem: Video In		
Size A4	Document Number 30420-007	Rev PA3
Date: Saturday, September 29, 2007	Sheet 7	of 16

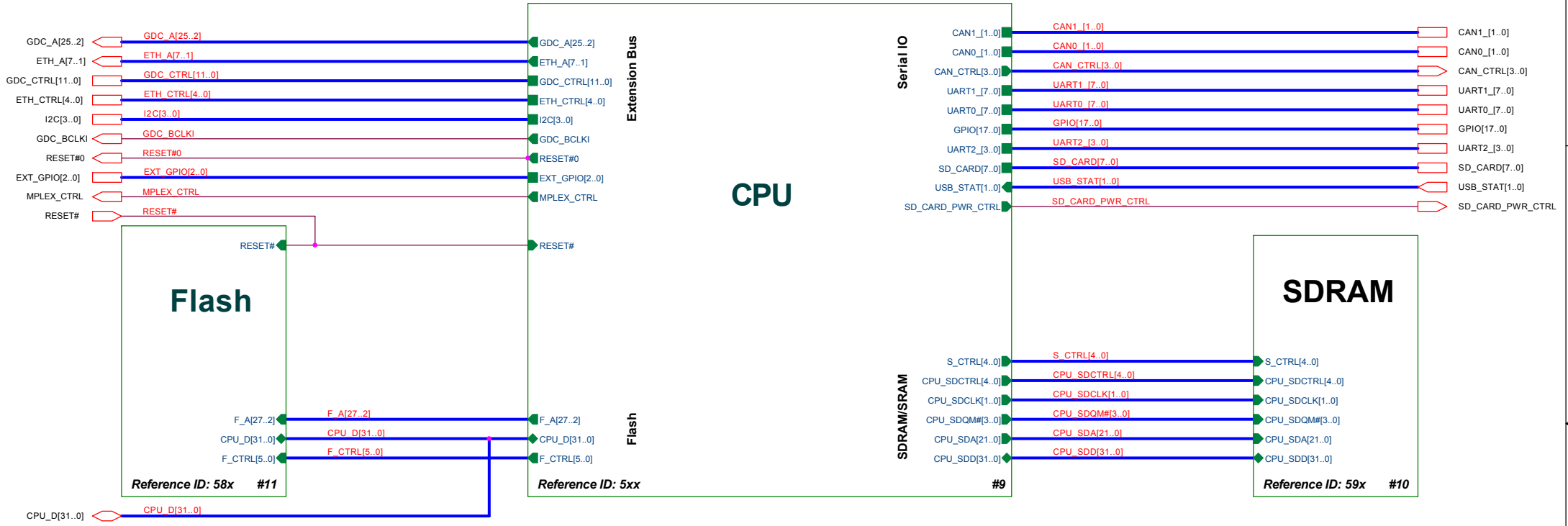

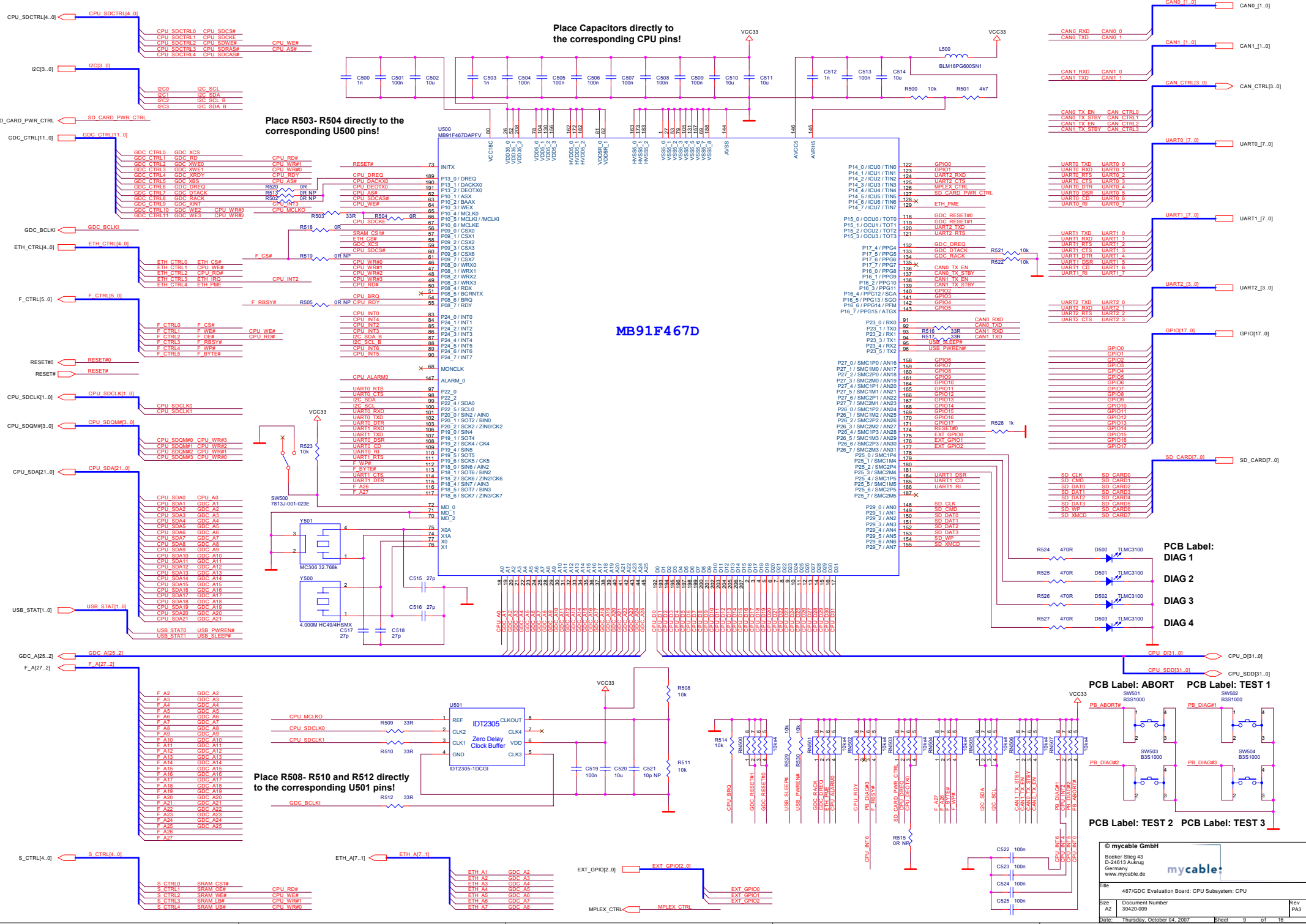

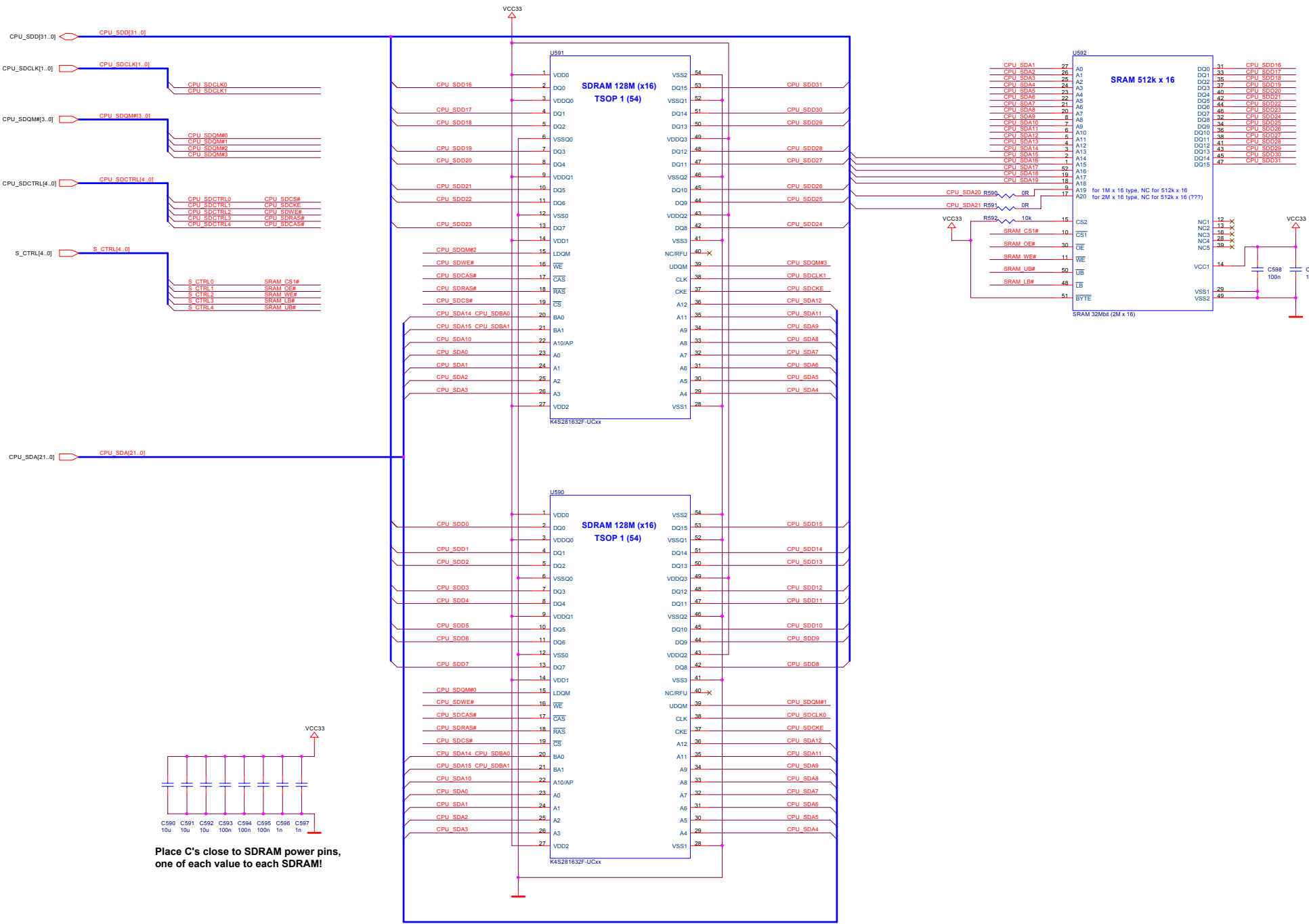

high HW

low HW

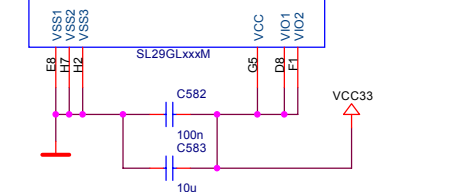
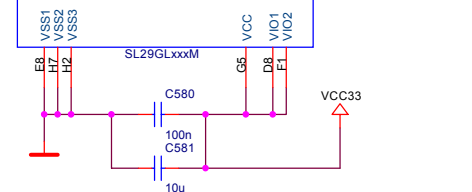
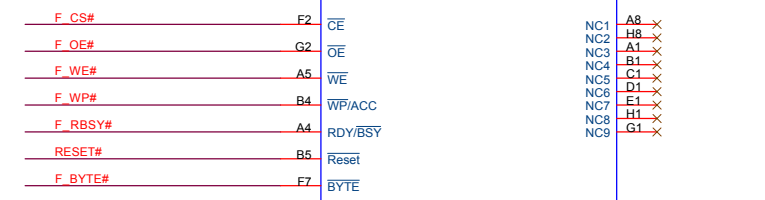
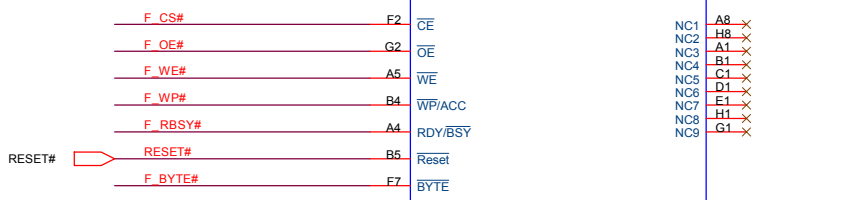
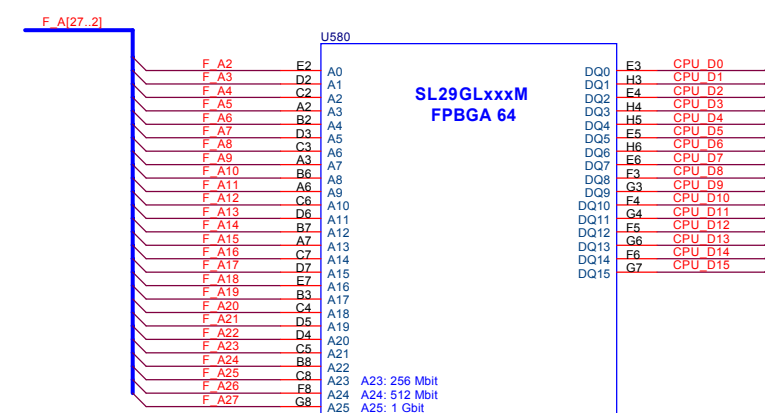
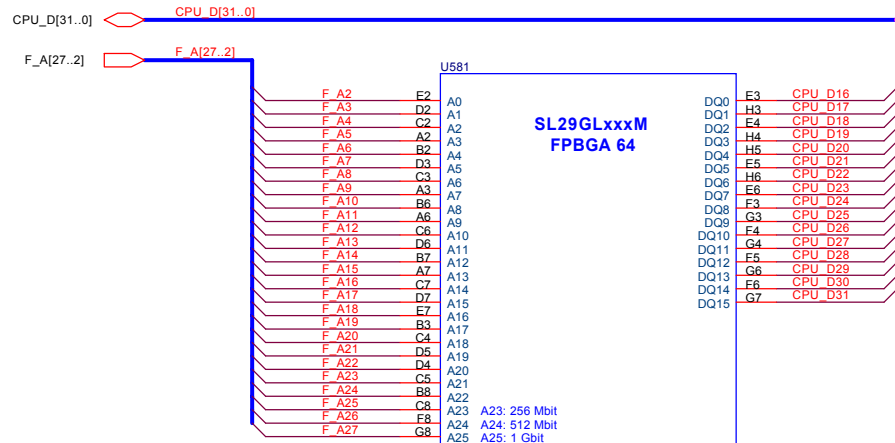

Place Cs directly to VCC/VIO and VSS pins!

Place Cs directly to VCC/VIO and VSS pins!

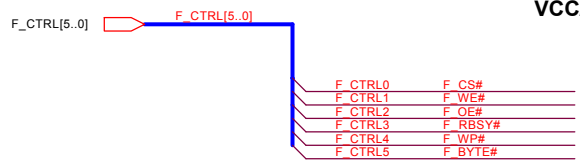

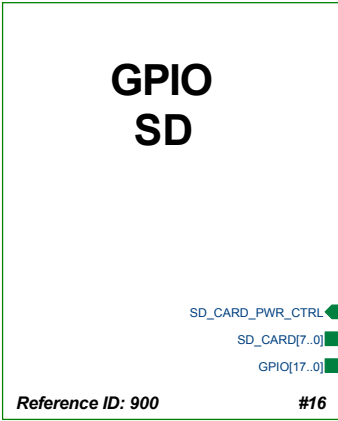
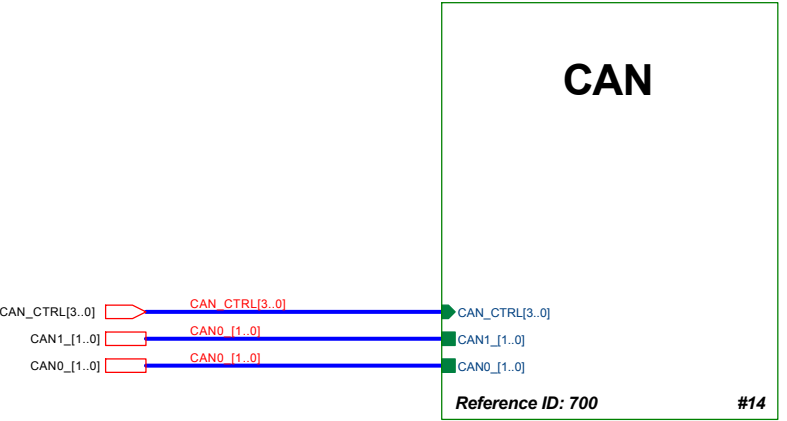
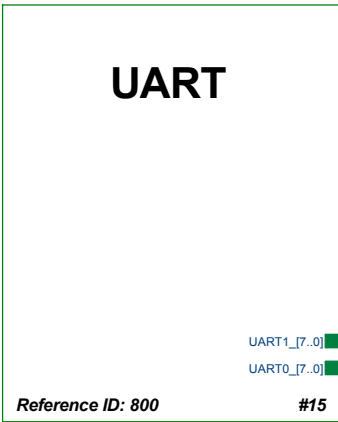
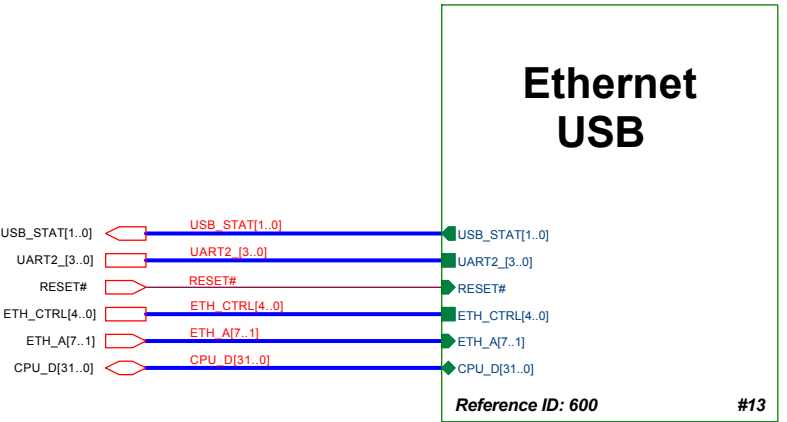

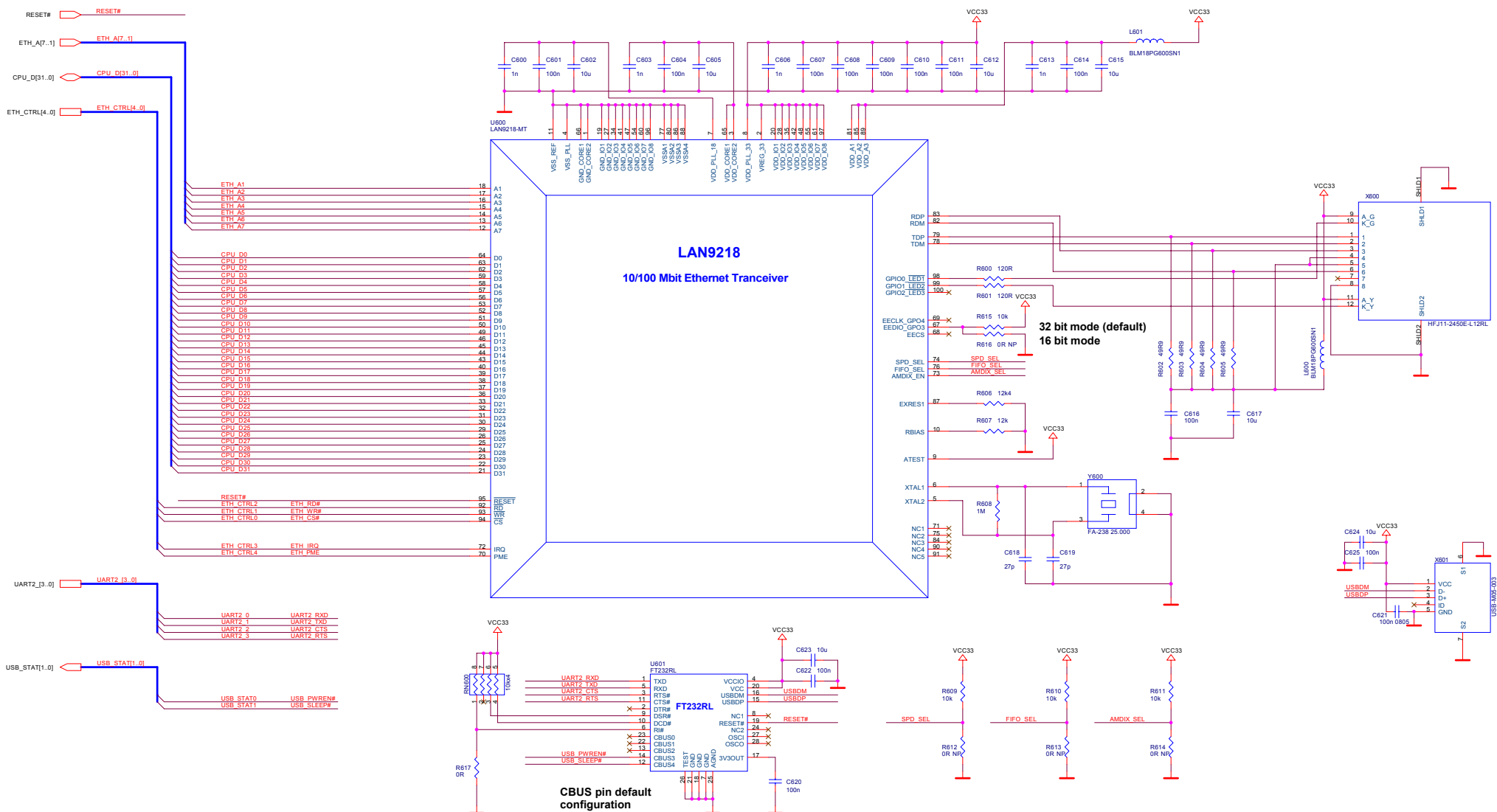

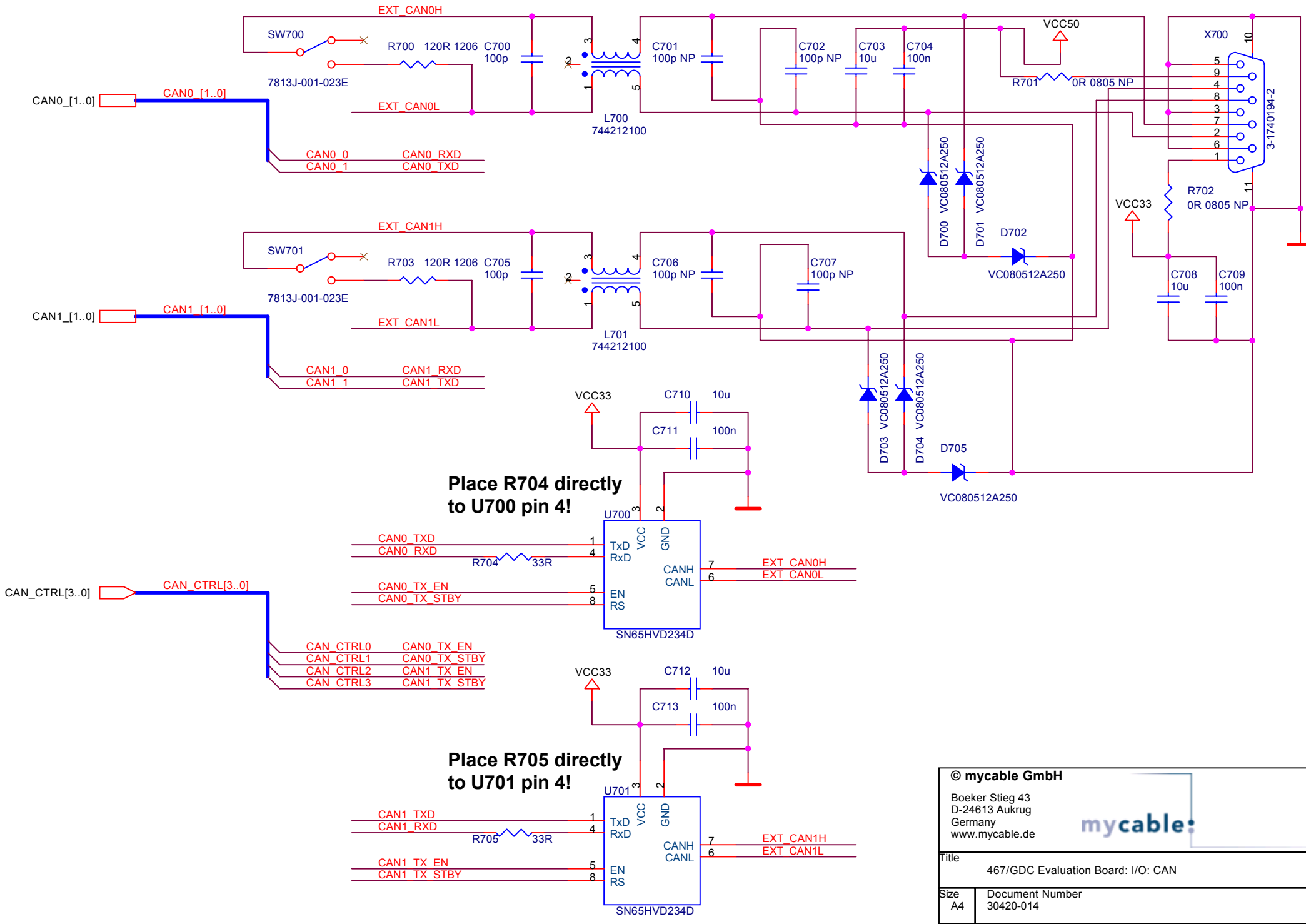

Place R704 directly to U700 pin 4!

Place R705 directly to U701 pin 4!

© mycable GmbH		
Boeker Stieg 43 D-24613 Aukrug Germany www.mycable.de		
Title 467/GDC Evaluation Board: I/O: CAN		
Size A4	Document Number 30420-014	Rev PA3
Date Saturday, September 29, 2007	Sheet 14	of 16

