

**JADE Evaluation Board
Extension Video Output
Revision: PA3**

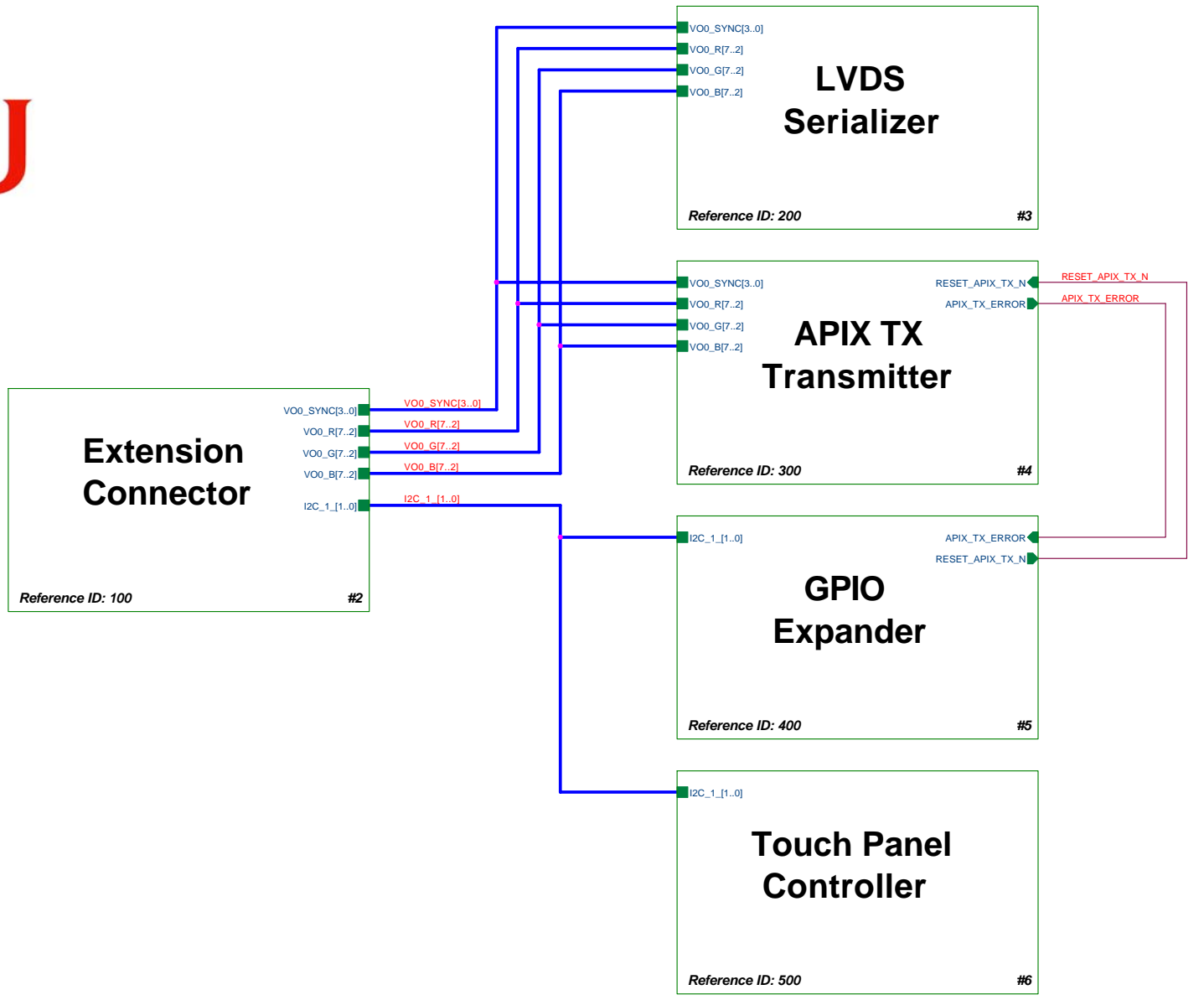

Hierarchy	Part References
+---#1 JADE Evaluation Board Extension Video Output - Top	
+---#2 Extension Connector	1xx
+---#3 LVDS Serializer	2xx
+---#4 APIX Transmitter	3xx
+---#5 GPIO Expander	4xx
+---#6 Touch Panel Controller	5xx

© mycable GmbH
 Gartenstr. 10
 D-24534 Neumünster
 Germany
 www.mycable.de

Title: Fujitsu JADE Evaluation Board Extension Video Output: Top

Size: A3	Document Number: 30 320 000	Rev: PA3
----------	-----------------------------	----------

Date: Tuesday, July 17, 2007 Sheet 1 of 6

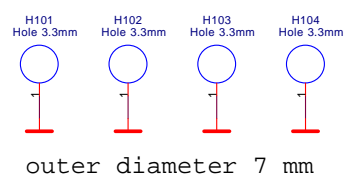
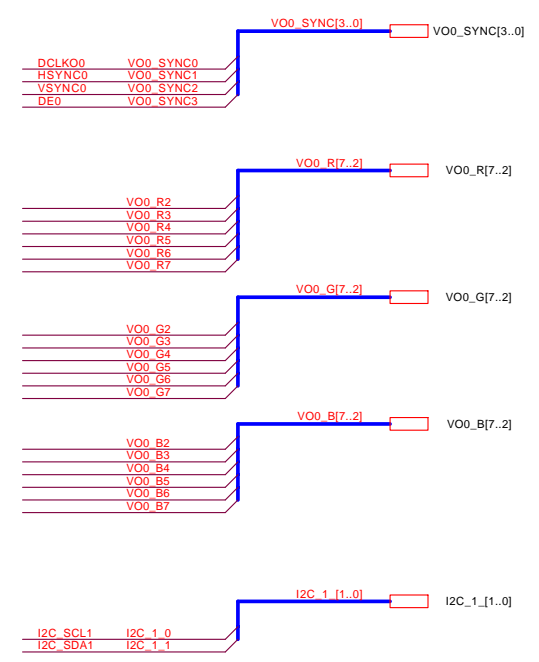
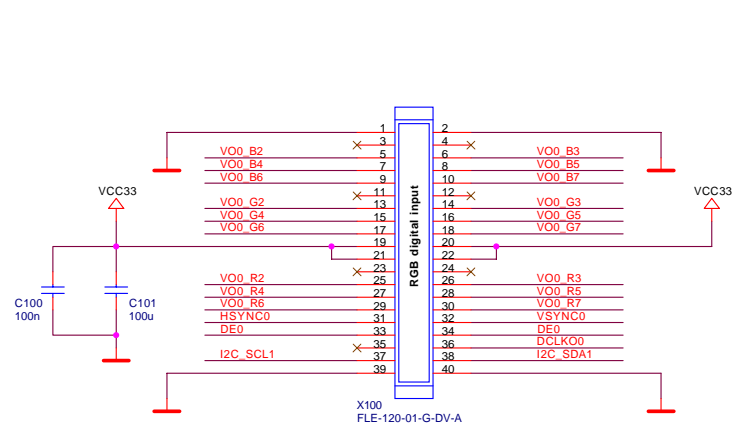

© mycable GmbH
Gartenstr. 10
D-24534 Neumünster
Germany
www.mycable.de

Title
Fujitsu JADE Evaluation Board Extension Video Output: Extension

Size A3	Document Number 30 320 000	Rev PA3
------------	-------------------------------	------------

Date: Wednesday, July 18, 2007 Sheet 2 of 6

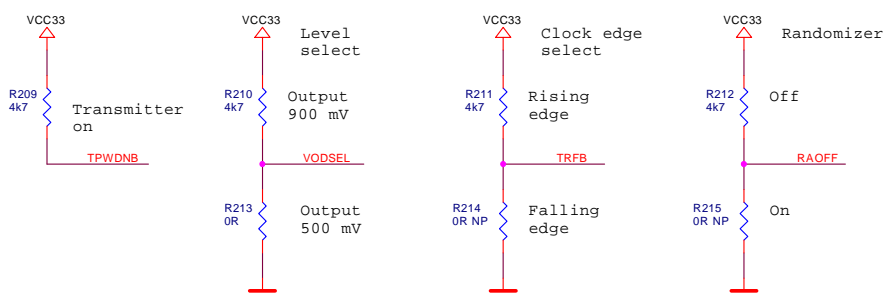
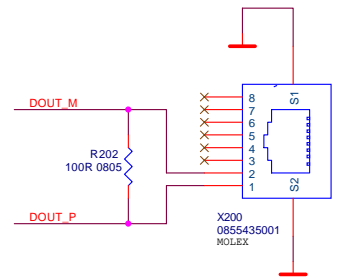
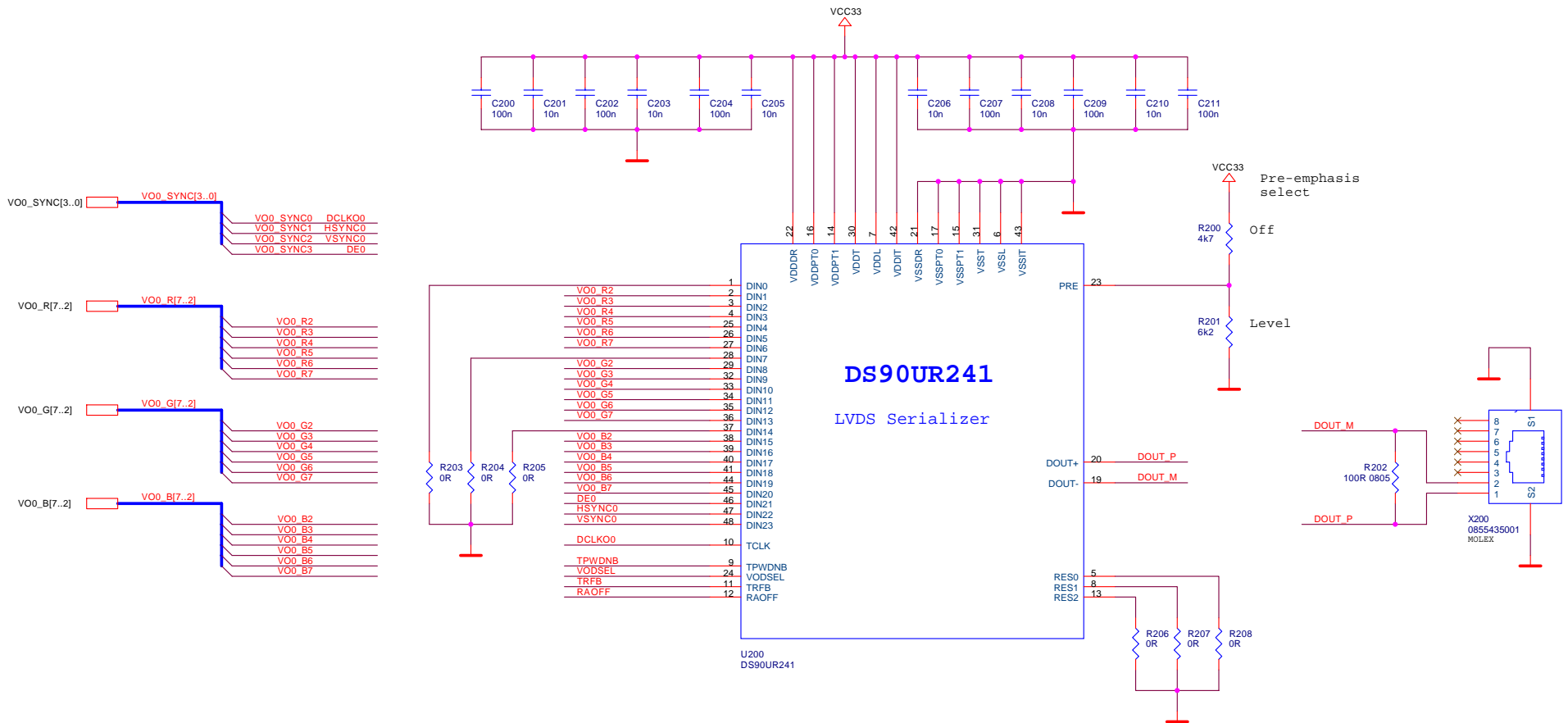

© mycable GmbH
 Gartenstr. 10
 D-24534 Neumünster
 Germany
 www.mycable.de

mycable

Title
 Fujitsu JADE Evaluation Board Extension Video Output: LVDS Transmitter

Size A3	Document Number 30 320 000	Rev PA3
------------	-------------------------------	------------

Date: Tuesday, July 17, 2007 Sheet 3 of 6

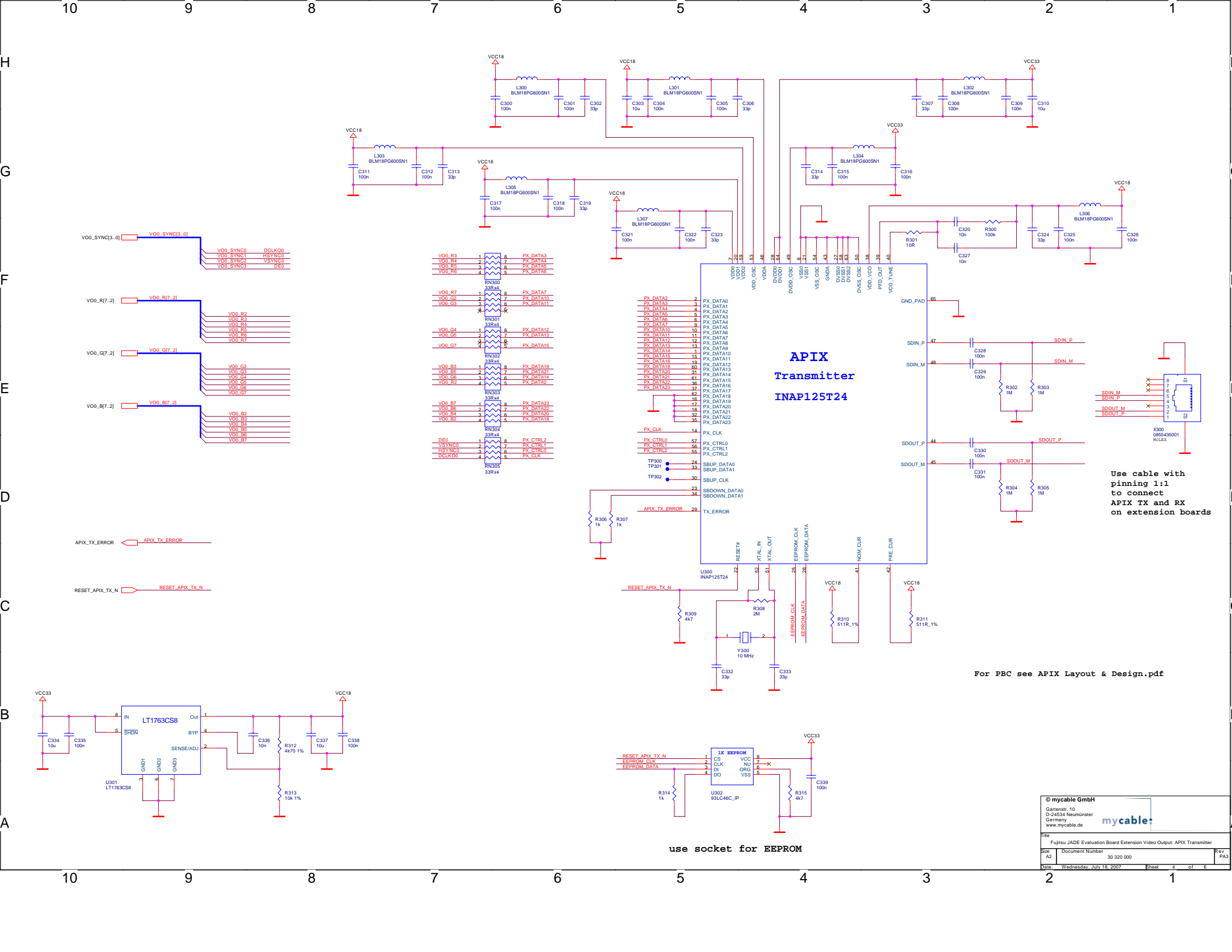

**APiX
Transmitter
INAP125T24**

Use cable with pinning 1:1 to connect APiX TX and RX on extension boards

For PBC see APiX Layout & Design.pdf

use socket for EEPROM

© mycable GmbH		
Gartenstr. 10 D-24534 Neumünster Germany www.mycable.de		
File	Fujitsu JADE Evaluation Board Extension Video Output: APiX Transmitter	
Size	Document Number	30 320 000
Date	Wednesday, July 18, 2007	
Sheet	4 of 8	

RESET_APIX_TX_N \leftarrow RESET_APIX_TX_N

APIX_TX_ERROR \leftarrow APIX_TX_ERROR

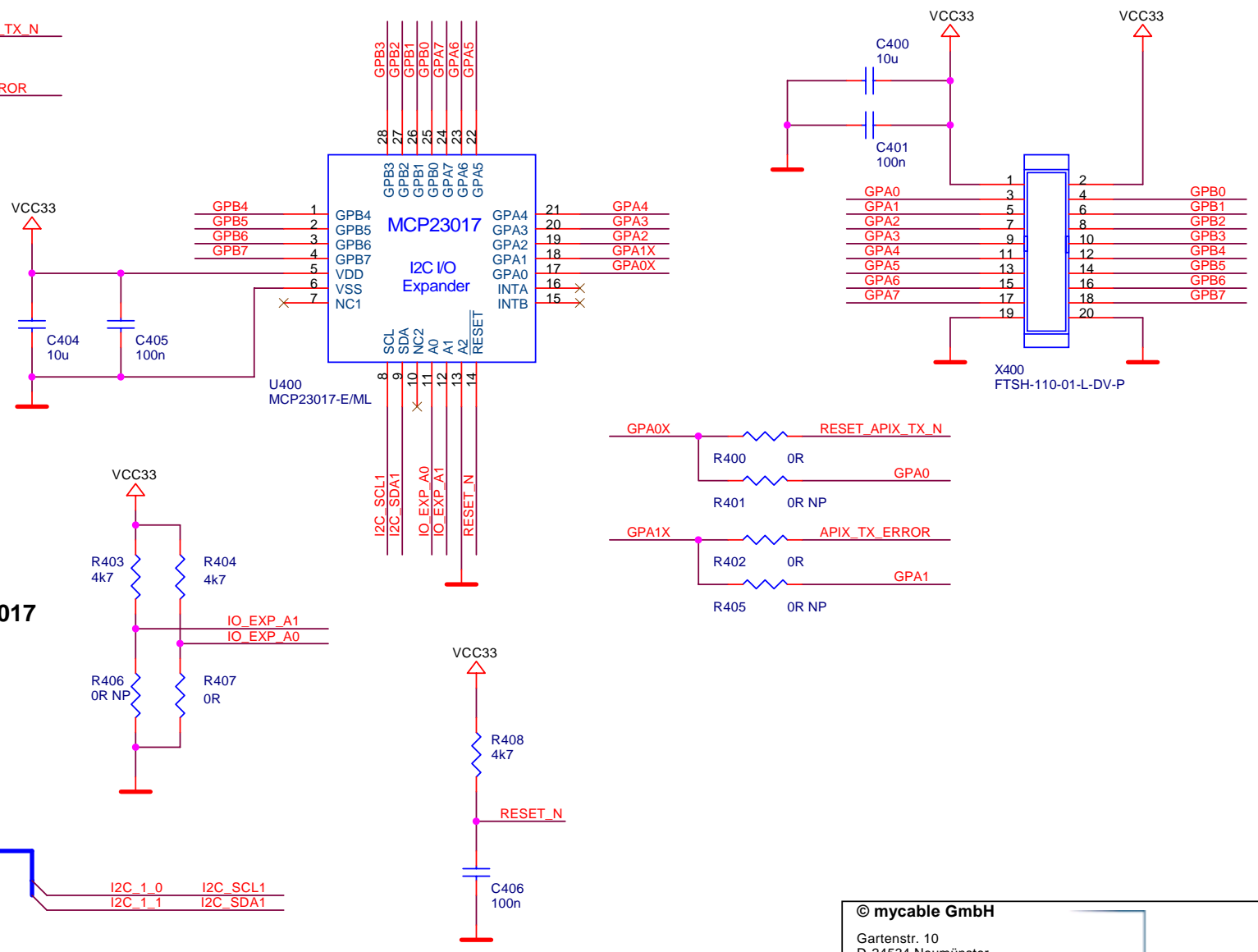

I2C addresses of MCP23017
 read: 0x45, write: 0x44

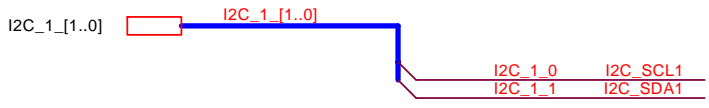

© mycable GmbH
 Gartenstr. 10
 D-24534 Neumünster
 Germany
 www.mycable.de

mycable

Title
 Fujitsu JADE Evaluation Board Extension Video Output: GPIO

Size A4	Document Number 30 320 000	Rev PA3
------------	-------------------------------	------------

Date: Tuesday, July 17, 2007 Sheet 5 of 6

I2C addresses of TSC2007
 read: 0x97, write: 0x96

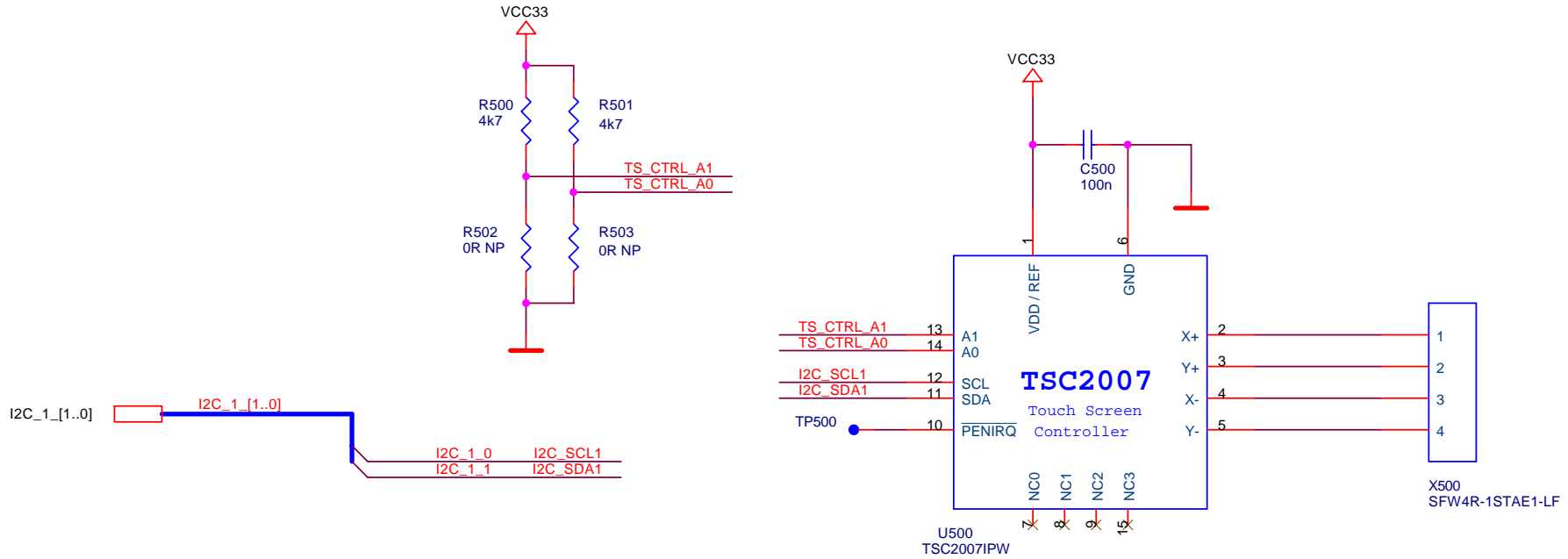

© mycable GmbH
 Gartenstr. 10
 D-24534 Neumünster
 Germany
 www.mycable.de

mycable

Title
 Fujitsu JADE Evaluation Board Extension Video Output: Touch Panel Control

Size A4	Document Number 30 320 000	Rev PA3
------------	-------------------------------	------------

Date: Tuesday, July 17, 2007 Sheet 6 of 6