

Application Note



MB86297A 'Carminé' Video Capture Unit Colour Conversion

© Fujitsu Microelectronics Europe GmbH

History

Date	Author	Version	Comment
25.02.2008	Anders Ramdahl	0.01	First draft
26.02.2008	Anders Ramdahl	0.02	Second draft
10.03.2008	Anders Ramdahl	1.00	First release

Warranty and Disclaimer

To the maximum extent permitted by applicable law, Fujitsu Microelectronics Europe GmbH restricts its warranties and its liability for **all products delivered free of charge** (eg. software include or header files, application examples, **Application Notes**, target boards, evaluation boards, engineering samples of IC's etc.), its performance and any consequential damages, on the use of the Product in accordance with (i) the terms of the License Agreement and the Sale and Purchase Agreement under which agreements the Product has been delivered, (ii) the technical descriptions and (iii) all accompanying written materials. In addition, to the maximum extent permitted by applicable law, Fujitsu Microelectronics Europe GmbH disclaims all warranties and liabilities for the performance of the Product and any consequential damages in cases of unauthorised decompiling and/or reverse engineering and/or disassembling. **Note, all these products are intended and must only be used in an evaluation laboratory environment.**

1. Fujitsu Microelectronics Europe GmbH warrants that the Product will perform substantially in accordance with the accompanying written materials for a period of 90 days form the date of receipt by the customer. Concerning the hardware components of the Product, Fujitsu Microelectronics Europe GmbH warrants that the Product will be free from defects in material and workmanship under use and service as specified in the accompanying written materials for a duration of 1 year from the date of receipt by the customer.
2. Should a Product turn out to be defect, Fujitsu Microelectronics Europe GmbH's entire liability and the customer's exclusive remedy shall be, at Fujitsu Microelectronics Europe GmbH's sole discretion, either return of the purchase price and the license fee, or replacement of the Product or parts thereof, if the Product is returned to Fujitsu Microelectronics Europe GmbH in original packing and without further defects resulting from the customer's use or the transport. However, this warranty is excluded if the defect has resulted from an accident not attributable to Fujitsu Microelectronics Europe GmbH, or abuse or misapplication attributable to the customer or any other third party not relating to Fujitsu Microelectronics Europe GmbH.
3. To the maximum extent permitted by applicable law Fujitsu Microelectronics Europe GmbH disclaims all other warranties, whether expressed or implied, in particular, but not limited to, warranties of merchantability and fitness for a particular purpose for which the Product is not designated.
4. To the maximum extent permitted by applicable law, Fujitsu Microelectronics Europe GmbH's and its suppliers' liability is restricted to intention and gross negligence.

NO LIABILITY FOR CONSEQUENTIAL DAMAGES

To the maximum extent permitted by applicable law, in no event shall Fujitsu Microelectronics Europe GmbH and its suppliers be liable for any damages whatsoever (including but without limitation, consequential and/or indirect damages for personal injury, assets of substantial value, loss of profits, interruption of business operation, loss of information, or any other monetary or pecuniary loss) arising from the use of the Product.

Should one of the above stipulations be or become invalid and/or unenforceable, the remaining stipulations shall stay in full effect.

0 Abstract

This document describes the Y_C, C_b to RGB colour conversion algorithm implemented in the capture units of the MB86297A graphics controller from Fujitsu. The description is meant to explain the implementation from an algorithmic point of view and may deviate from the actual hardware implementation.

The information found in this document is also valid for other Fujitsu graphics controllers, including:

- MB86276
- MB86277
- MB86290 through MB86296
- MB86R01

Please refer to the documentation of the individual devices for further details.

1 References

Referenced documents:

- CHWRM Fujitsu Microelectronics
MB86297A 'Carmine' Hardware Reference Manual
rev. 1.22, 25 June 2007
- ITU656 International Telecommunication Union
ITU-R BT.656-5 (12/07), Interface for digital component video signals in 525-line and 625-line television systems operating at the 4:2:2 level of Recommendation ITU-R BT.601
<http://www.itu.int/>

Additional information:

- ITU601 International Telecommunication Union
ITU-R BT.601-6 (01/07), Studio encoding parameters of digital television for standard 4:3 and wide screen 16:9 aspect ratios
<http://www.itu.int/>

All Fujitsu documents listed above are available on the Fujitsu Graphics Solutions website:

<http://www.fujitsu.com/emea/services/microelectronics/displaycontrollers/>

2 Definitions

Fixed point arithmetic:

- $Sp.f$ A signed fixed point number with a total of p bits, of which f are fractional, e.g. S13.2 represents a signed 13-bit fixed point number with 11 integer and 2 fractional bits.
The fractional specifier ($.f$) can be left out for signed integer values, e.g. S9 represents a signed 9-bit integer value.
- $Up.f$ An unsigned fixed point number with a total of p bits, of which f are fractional, e.g. U10.8 represents a signed 10-bit fixed point number with 2 integer and 8 fractional bits.
The fractional specifier ($.f$) can be left out for unsigned integer values, e.g. U8 represents an unsigned 8-bit integer value.

3 Colour Conversion

The colour conversion of the capture unit is implemented as a three stage pipeline.

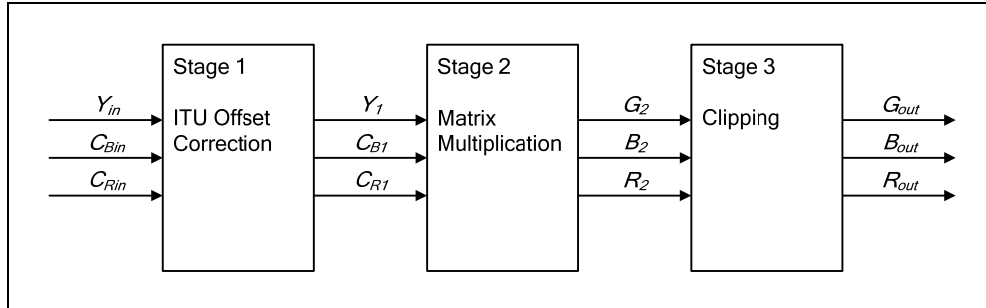

Figure 1 Colour Conversion Pipeline

The stages have been designed to minimize truncation and rounding errors that may occur during the calculations. At the last stage, the values are truncated to fit with an 8 bit range. Should the values from the previous stages fall outside this range, the values are clipped to the minimum and maximum values, respectively.

3.1 Input Data Format

The input data should be formatted in accordance with the ITU656 specification.

ITU656 specifies how a dynamic range of 700 mV should be encoded into U8 values. Figure 2 shows how the data should be encoded.

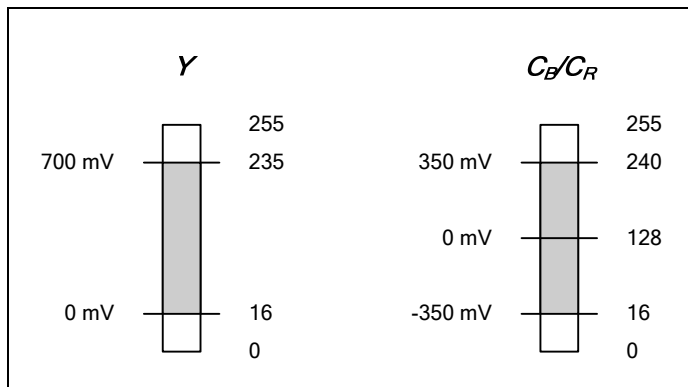

Figure 2 Dynamic Ranges of ITU656 Data

The valid ranges of the $YC_B C_R$ values have been marked as gray in the figure. Values outside these ranges are used for synchronisation purposes.

Currently, the ITU656 specification only defines the values 0 and 255 for synchronisation purposes, which leaves some values outside the valid range undefined. Some video decoders take advantage of these undefined values to allow for some undershoot and overshoot of the valid range.

The capture units of the MB86297A allow the input range to be extended. The allowed input ranges are defined in (1).

$$(1) \quad \begin{cases} Y_{in} \in [1 \ 254] \\ C_{Bin} \in [1 \ 254] \\ C_{Rin} \in [1 \ 254] \end{cases}$$

3.2 Pipeline Stage 1 – ITU Offset Correction

The first pipeline stage subtracts the offsets, i.e. the values representing 0 mV, specified in ITU656.

$$(2) \quad \begin{cases} Y_1 = Y_{in} - 16 \\ C_{B1} = C_{Bin} - 128 \\ C_{R1} = C_{Rin} - 128 \end{cases}$$

The precision of the results (Y_1 , C_{B1} and C_{R1}) is S9.

3.3 Pipeline Stage 2 – Matrix Multiplication

The second pipeline stage transforms the $YC_B C_R$ colour values into the corresponding RGB values. This is done with a matrix multiplication.

$$(3) \quad \begin{bmatrix} G_2 \\ B_2 \\ R_2 \end{bmatrix} = \frac{1}{256} \begin{bmatrix} 299 & -100 & -209 \\ 299 & 516 & 0 \\ 299 & 0 & 408 \end{bmatrix} \begin{bmatrix} Y_1 \\ C_{B1} \\ C_{R1} \end{bmatrix}$$

The precision of the matrix coefficients is U10.8. The resulting products (S19.8) are truncated to S13.2 precision before reaching the subsequent additions (or subtractions for the negative coefficients).

3.4 Pipeline Stage 3 – Clipping

The last pipeline stage clips the S13.2 values into the U8 precision used by the subsequent processing stages of the graphics controller.

$$(4) \quad \begin{cases} G_{out} = clip(G_2) \\ B_{out} = clip(B_2) \\ R_{out} = clip(R_2) \end{cases}$$

The clip function limits the output range and truncates the fractional bits, as can be seen in (5).

$$(5) \quad clip(x) = \begin{cases} 0 & x < 0 \\ \lfloor x \rfloor & 0 \leq x \leq 255 \\ 255 & x > 255 \end{cases}$$

Appendix A Colour Conversion Excel Sheet

An excel sheet simulating the colour conversion algorithm of the capture unit is available.

All calculations in the excel sheet are done with the same precision as the hardware. Warnings are shown if the *RGB* values are clipped in the final stage of the pipeline.