

MB86061

12-Bit 400MSa/s Digital to Analog Converter

FME/MS/SFDAC1E/FL_1/4269

The Fujitsu MB86061 is a high performance 12-bit 400MSa/s digital to analog converter (DAC). Use of novel techniques for the converter architecture delivers high speed operation consistent with BiCMOS or bipolar devices but at the low power of CMOS. Fujitsu's proprietary architecture is the subject of several patent applications. Excellent SFDR performance coupled with high speed conversion rate and low power make this device particularly suitable for high performance communication systems, graphics and test/instrumentation equipment applications.

Features

- 12-bit 400MSa/s Digital to Analog converter
- True ECL digital interface (-2V supply)
- 86dBc SFDR @ 10MHz, 200MSa/s (Shuffle On)
- Low power, +3.3V and -2V operation (308mW @ 300MSa/s)
- Performance enhanced pinout with on-chip decoupling
- 0.35µm CMOS technology with Triple Well
- Industrial temperature range (-40 °C / +85 °C)
- Plastic Package 64-pin QFP

Applications

- Test & Instrumentation equipment
- Communications systems
- High performance graphics

PLASTIC PACKAGE QFP-64

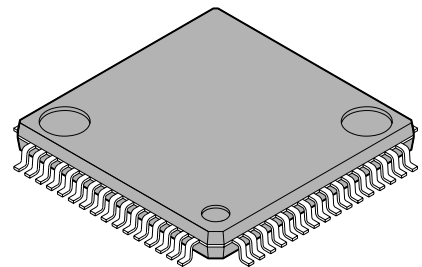

(FPT-64P-M09)

Ordering Information

Part	Order Number
MB86061 Datasheet	Contact Sales
MB86061 DAC	MB86061PFQ
MB86061 Development Kit	DK86061-3
MB86061 Development Kit User Manual	Contact Sales

This product has Patents applied for in the US and elsewhere including GB2333191A, EP0935345A, JP11-274934A, GB2333171A, EP0930717A, JP11-274935A, GB2333190A, EP0929158A, JP11-243339A, GB2335097A, EP0940923A, JP11-317667A, GB2335076A, EP0940852A, JP11-251530A.

MB86061 12-Bit 400MSa/s Digital to Analog Converter

Functional Description

The MB86061 is a high performance 12-bit 400MSa/s digital to analog converter. Versatile interfacing via the 12-bit true ECL data input allows existing system requirements to be accommodated, using either offset binary or 2's complement data formats. The device requires an external clock.

A 1.25V bandgap reference is provided on-chip, which may be overdriven where an external reference is to be used. A power-down mode is enabled during device reset, with the current output drive and reference circuitry disabled.

The device is manufactured in a 0.35 μ m advanced CMOS process with Triple Well extension giving improved isolation between analog blocks and digital-analog.

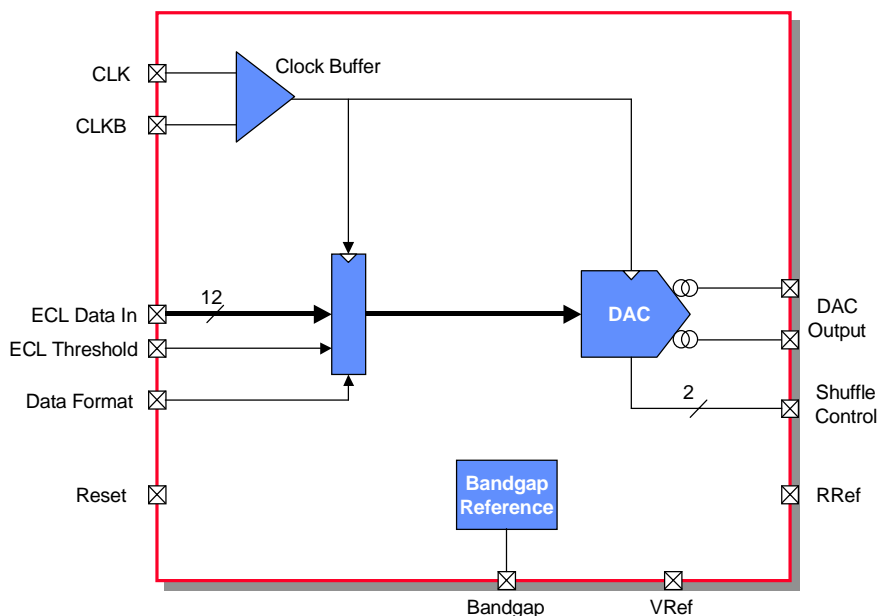

MB86061 Functional Block Diagram

Converter Architecture

The DAC core incorporates a number of novel design aspects that are subject to patent applications. Key to its operation are the current sources where segmented, common centroid, interleaved techniques for the most significant bits, as well as load matching ensure good linearity and low distortion to at least the 12-bit level. In the switch elements tracking capacitance is minimised to improve settling, while controlled rise and fall times improve SFDR performance. Finally the digital decoding uses a 3-dimensional addressing approach to minimise propagation delays from latch to element.

MB86061 12-Bit 400MSa/s Digital to Analog Converter

Segment Shuffling

The DAC core incorporates a proprietary segment shuffling capability which is provided to further improve linearity, and hence improve SFDR. This feature reduces any signal level dependent effects on linearity as the same code can be generated by the same number of MSB cells but taken from any quarter of the MSB segments. Segment shuffling can be selected to operate every 4, 8 or 16 updates of the DAC output using a random shuffle sequence between the four segments.

The effect of segment shuffling is to produce a spread noise spectrum, raising the overall noise floor, but reducing the distortion. For minimum distortion when generating low frequency signals, it is recommended that the shuffling clock rate is no more than 25MHz (DAC Rate / Segment Shuffling Setting). However, low shuffle clock rates give reduced spreading out of distortion components.

Single Tone SFDR Performance

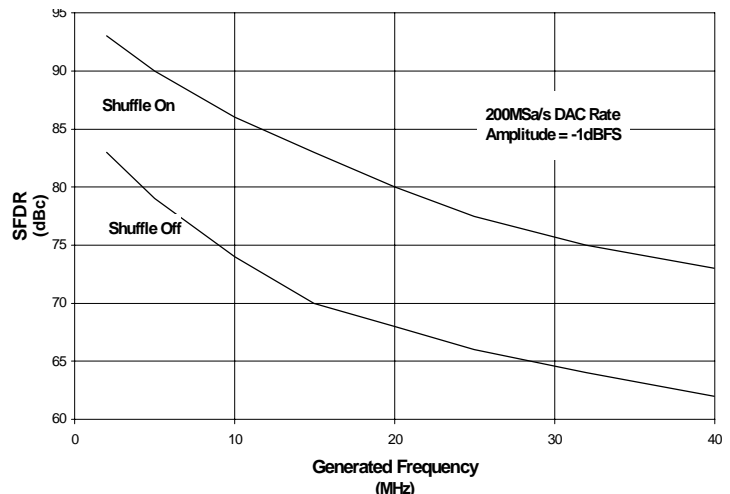

Spurious Free Dynamic Range (SFDR)

Spurious Free Dynamic Range (SFDR) is defined as the highest spurious product (harmonic or non-harmonically related) within a defined bandwidth while generating a test tone or tones. SFDR varies with amplitude and frequency of the test tone(s) and is either quoted as the difference between the tone and highest spurious component (dBc) or referenced to full scale (dBFS). The measurement bandwidth is typically regarded as DC to Nyquist but occasionally systems will specify an appropriate narrow band.

Development Kit

A development kit, reference DK86061, is available for the MB86061 12-Bit 400MSa/s Digital to Analog Converter. The kit includes an evaluation board that enables simple and effective evaluation of the device.

The board provides a complete evaluation environment for the DAC. A transformer coupled differential output interface is provided to simplify integration into target applications and development environments. An RF clock source can be connected via the transformer coupled input, and 12-bit data via a 40-way IDC header.

The development kit includes,

- Evaluation board with MB86061 device fitted
- Spare MB86061 for customer development
- User Manual



MB86061 12-Bit 400MSa/s Digital to Analog Converter

Worldwide Headquarters

Japan

Fujitsu Limited

Tel: +81 44 754 3753
Fax: +81 44 754 3329

1015 Kamikodanaka 4-1-1
Nakahara-ku
Kawasaki-shi
Kanagawa-ken 211-88
Japan

<http://www.fujitsu.co.jp/>

Asia

Fujitsu Microelectronics Asia Pte Limited

Tel: +65 281 0770
Fax: +65 281 0220

151 Lorong Chuan
#05-08 New Tech Park
Singapore 556741

<http://www.fmap.com.sg/>

USA

Fujitsu Microelectronics Inc

Tel: +1 408 922 9000
Fax: +1 408 922 9179

3545 North First Street
San Jose CA 95134-1804
USA

Tel: +1 800 866 8608
Fax: +1 408 922 9179

Customer Response Center
Mon-Fri: 7am-5pm (PST)

<http://www.fujitsumicro.com/>

Europe

Fujitsu Microelectronics Europe GmbH

Tel: +49 6103 6900
Fax: +49 6103 690122

Am Siebenstein 6-10
D-63303 Dreieich-Buchsschlag
Germany

<http://www.fujitsu-fme.com/>

The contents of this document are subject to change without notice. Customers are advised to consult with FUJITSU sales representatives before ordering.

The information and circuit diagrams in this document presented as examples of semiconductor device applications, and are not intended to be incorporated in devices for actual use. Also, FUJITSU is unable to assume responsibility for infringement of any patent rights or other rights of third parties arising from the use of this information or circuit diagrams.

FUJITSU semiconductor devices are intended for use in standard applications (computers, office automation and other office equipment, industrial, communications, and measurement equipment, personal or household devices, etc.). CAUTION: Customers considering the use of our products in special applications where failure or abnormal operation may directly affect human lives or cause physical injury or property damage, or where extremely high levels of reliability are demanded (such as aerospace systems, atomic energy controls, sea floor repeaters, vehicle operating controls, medical devices for life support, etc.) are requested to consult with FUJITSU sales representatives before such use. The company will not be responsible for damages arising from such use without prior approval.

Any semiconductor devices have inherently a certain rate of failure. You must protect against injury, damage or loss from such failures by incorporating safety design measures into your facility and equipment such as redundancy, fire protection, and prevention of over-current levels and other abnormal operating conditions.

If any products described in this document represent goods or technologies subject to certain restrictions on export under the Foreign Exchange and Foreign Trade Control Law of Japan, the prior authorization by Japanese government should be required for export of those products from Japan.

FME/MS/SFDAC1E/FL_1/4269 - 1.2