

USB Function Core

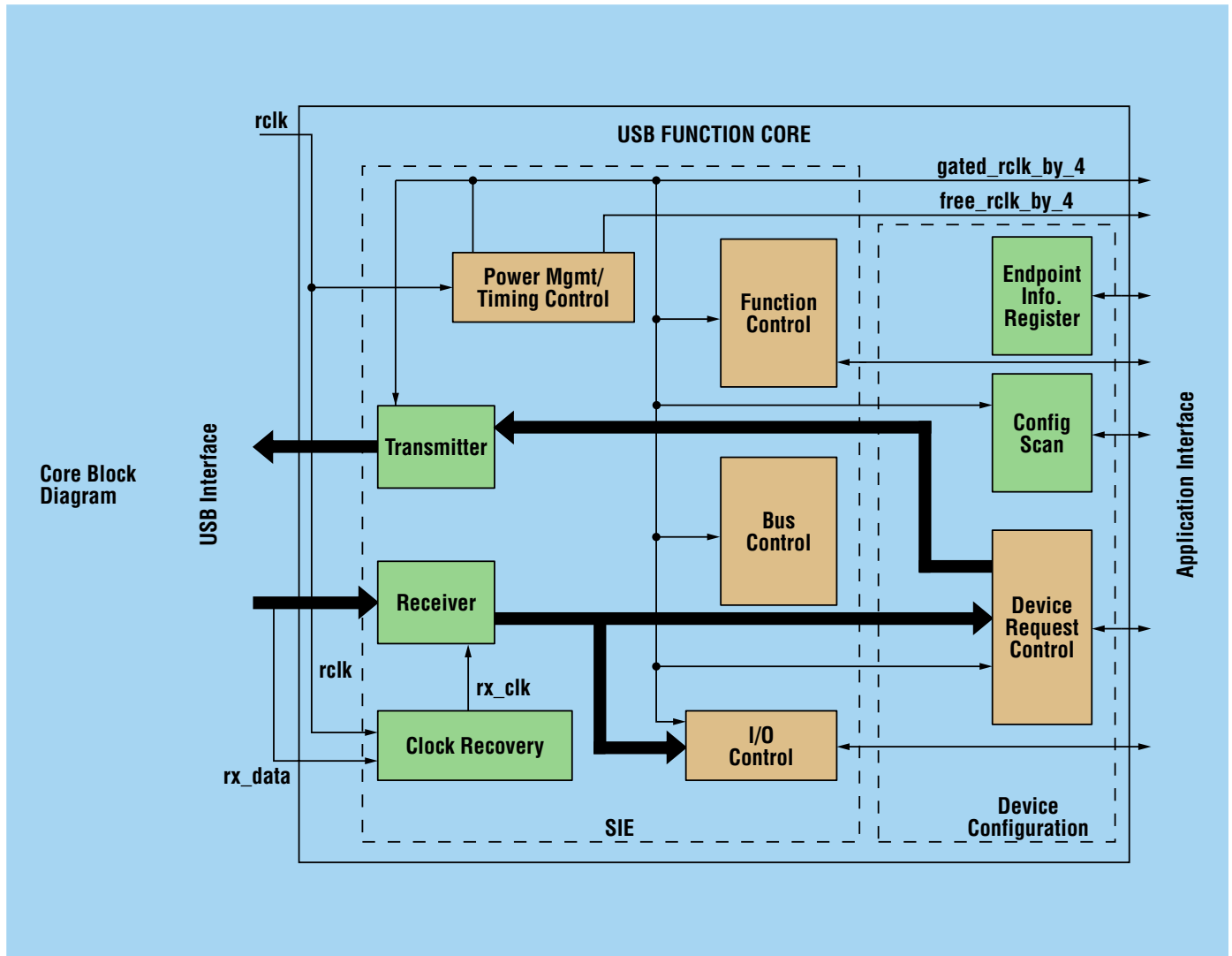
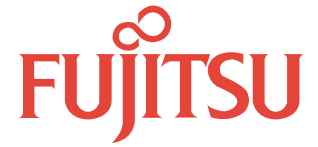

Features

- USB V1.0 compliant
- 12 Mb/s or 1.5 Mb/s data transfer rate
- Scalable physical parameters
- Selectable synchronous/asynchronous reset mode
- Suspend/resume logic provided
- Programmable number of end-points

Benefits

- Soft core that can be implemented in any technology
- Silicon-proven to decrease time-to-market
- Provides longer battery life in portable devices
- Scalability to meet different application speeds
- Supports a wide range of USB function device classes (low cost, low and medium speed)

USB Function Core

► Description

The USB Function Core is a synthesizable core and is part of the Fujitsu IPWare™ Library. This core is fully compliant with revision 1.0 of the USB specification.

This core includes two main modules: the Serial Interface Engine (SIE) and the Device Configuration module as shown in the block diagram.

The SIE module contains the receiver, transmitter, bus control, function control, I/O control, clock recovery, and power management/timing control modules. Together these modules manage the bit-level USB protocol. The SIE module transmits and receives USB packets, and handles parallel-to-serial and serial-to-parallel data conversion, NRZI encoding/decoding, bit surfing/stripping, and CRC checking generation. The SIE also monitors for and handles reset, suspend, and resume signaling.

The Device Configuration module contains the device request control, configuration scan, and endpoint information register modules. The device request control module receives and handles device requests, either processing them or passing them to an application for processing. The configuration scan module accesses the device, configuration, interface, and endpoint descriptors. The core expects the descriptors to be stored in a ROM or in another addressable element within the application logic. The endpoint information register module holds the current configuration, interface, and endpoint information for the device.

The USB Function Core is ideally suited for a variety of applications including, but not limited to, pointing devices, scanners, cameras, fax machines, printers, joysticks, and keyboards.

► Deliverables

A Fujitsu Microelectronics, Inc. application engineer works with the customer to select the process technology best suited to meet the customer's specific needs. After the technology is selected, the following information can be supplied to the customer:

- Encrypted Verilog RTL source code
- A hierarchical gate level netlist

FUJITSU MICROELECTRONICS, INC.

Corporate Headquarters
3545 North First Street, San Jose, California 95134-1804
Tel: (800) 866-8608 Fax: (408) 922-9179
E-mail: fmicro@fmi.fujitsu.com Web Site: <http://www.fujitsumicro.com>

© 1999 Fujitsu Microelectronics, Inc.
All company and product names are trademarks or registered trademarks of their respective owners.
Printed in the U.S.A. ASIC-FS-20829-11/99