

MB87M3550, The Fujitsu WiMAX
802.16-2004 SoC

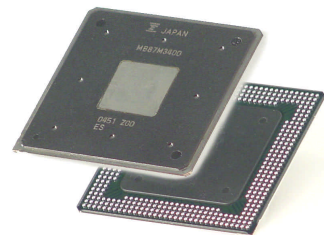

P R O D U C T B R I E F

With a MAC-to-PHY implementation of the IEEE 802.16-2004 broadband wireless access (BWA) standard, the Fujitsu WiMAX SoC, MB87M3550, offers a cost-effective solution for both subscriber station and base station applications. This highly integrated SoC implements MAC, PHY, radio control and all the necessary analog circuits for the appropriate 2 to 11GHz licensed or license-exempt bands.

The Fujitsu WiMAX SoC, MB87M3400, fully complies with the IEEE 802.16-2004 standard using an OFDM PHY. The SoC can operate in TDD or FDD modes and supports all the available channel bandwidths from 1.75MHz up to 20MHz bandwidths. A programmable frequency selection generates the sample clock for any desired bandwidth. When applying 64QAM modulation in a 20MHz channel and using all 192 sub-carriers, the SoC's data rate can go up to 75Mbps. Uplink subchannelization is supported as defined in the standard.

The SoC's integrated ARM926 RISC engine implements 802.16 upper layer MAC, scheduler, drivers, protocol stacks, and user application software. A multi-channel DMA controller handles high-speed transactions among various agents on a high-performance bus.

To offload processing from the upper layer MAC and enhance performance, the Fujitsu WiMAX SoC includes a separate ARC RISC/DSP engine to execute 802.16 lower layer MAC functions. The chip's multiple hardware-based encryption/decryption engines are tightly coupled with this lower layer MAC processor and can be enabled to provide full security for the MAC privacy sub-layer.

Key Features

- Full compliance with the IEEE 802.16-2004 standard
- Support for both subscriber stations and base stations for TDD or FDD applications
- High-performance modulation capabilities for complete versatility:
- 256 OFDM PHY with 64QAM, 16QAM, QPSK, and BPSK modulation
- Uplink subchannelization for 16 subchannels
- Flexible configuration for easy system integration:
 - High-performance ADC and DAC for flexible baseband interfacing
 - Automatic frequency control (AFC) with integrated DAC
 - Dynamic frequency selection (DFS) with integrated ADC
 - Integrated ADC for transmit and receive power measurements
 - Rich set of integrated peripherals and RF control
 - Programmable automatic gain control (AGC) for supporting a broad range of RF attenuators
- Security implementation based on DES, AES/CCM encryption/decryption
- Dual RISC processors for implementing upper and lower layer MAC
- Integrated memory controller and DMA controller
- Integrated Ethernet engine for network interface
- 436 BGA package
- Complete reference design with software and radio solution

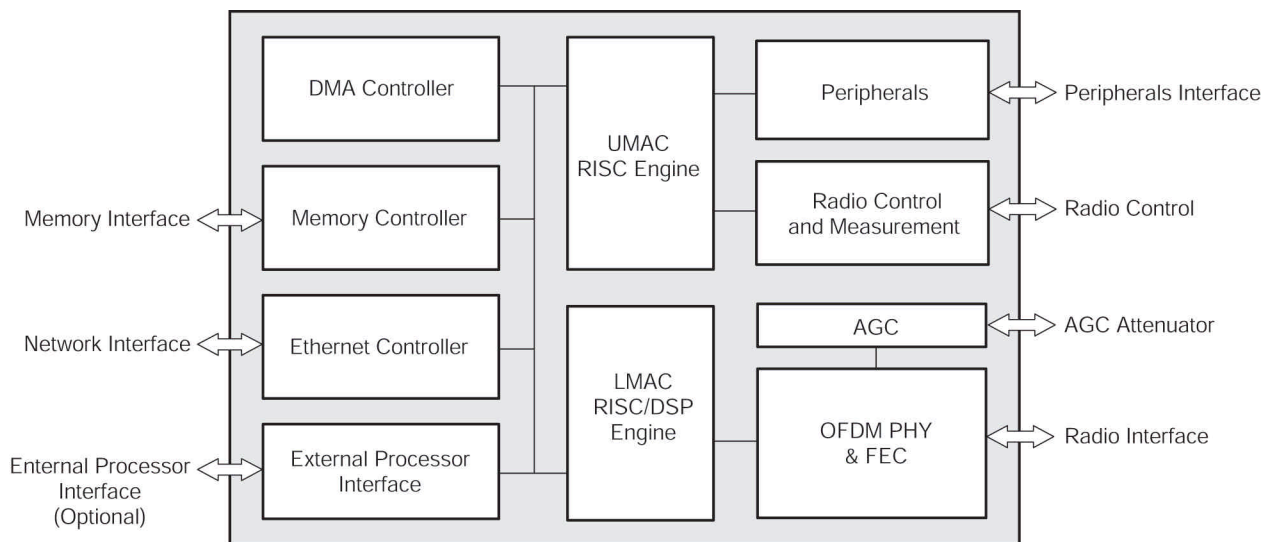

Figure 1 - A simplified block diagram of the Fujitsu WiMAX SoC, MB87M3550, shows the dual processors and main hardware blocks that implement a complete PHY-to-MAC wireless MAN solution.

System Applications

The Fujitsu WiMAX SoC suits several types of applications:

- BWA systems compliant with WiMAX specifications
 - Low-cost subscriber stations
 - Enterprise CPEs
 - Base stations
- 2 to 11GHz licensed and license-exempt bands
- Suitable independent frequency bands at 2.5, 3.5, 3.6 or 5.8GHz
- Half FDD / full FDD or TDD applications
- Programmable automatic gain control (AGC) for supporting a broad range of RF attenuators
- Security implementation based on DES, AES/CCM encryption/decryption

Two Fujitsu WiMAX SoCs work together to implement full-duplex FDD applications. The SoC can also work with an external processor to enhance performance in demanding base-station applications.

Reference Designs

Complete reference designs are available for various purposes. The process toward certification by the WiMAX Forum™ is underway for the full-system version. This reference design includes all the software and hardware required for a cost-effective system solution.

Reference Design Hardware Platforms

Several hardware platforms are available with the performing chip, software, and system verification. The reference board evaluation system for subscriber stations (Figure 2) can be configured to support either TDD or HDX FDD, depending on the radio selection. The simplified base station evaluation system (Figure 3) provides an example of a full duplex FDD implementation using an external processor.

The key features of the evaluation boards include:

- RF port interface for third-party radio
- Radio module
- Network interface
- On-board memory
- On-board control using SPI, I2C, and GPIO
- Debug port interfaces
- RS232C interface port
- External power supply interface

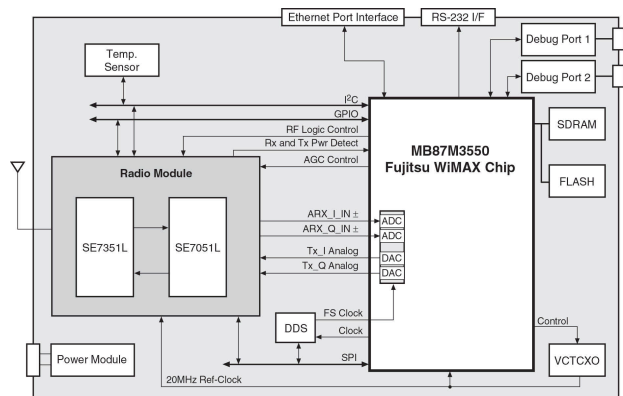

Figure 2 - TDD or HDX FDD Reference Board Evaluation System

Reference Design Software Platform

Major features of the Fujitsu 802.16 software platform include the following:

- Compliance with the IEEE 802.16-2004 standard specification
- MAC security sub-layer for subscriber station authentication and data encryption
- Multiple service class support to differentiate service quality
- Dynamic service management to activate service class when needed
- MAC portability to different RTOSes

The typical 802.16 software platform available from Fujitsu contains the following components:

- Host software (which runs on either the on-chip ARM9 or external processor) with the following sub-components:
 - Board support packages (BSPs) for popular operating systems
 - RTOS wrapper
 - Device drivers, such as Ethernet, IIC, SPI, and UART
 - Base station or subscriber station management and application
 - 802.16 upper layer MAC
- 802.16 PHY service access point and lower layer MAC (PSAP/LMAC) firmware (which runs on the on-chip ARC processor)

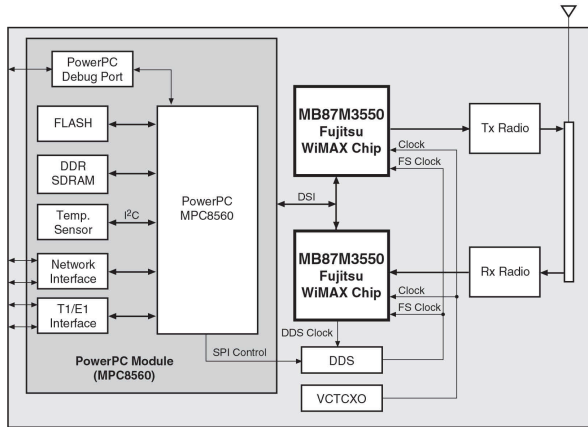

Figure 3 - Full Duplex FDD Reference Board Evaluation System

As shown in an overview of Fujitsu's software platform (Figure 4), the 802.16 upper layer MAC accesses the OFDM PHY through PSAP/LMAC firmware running on the on-chip ARctangent core. In addition to providing PHY access primitives, the PSAP/LMAC firmware includes some 802.16 lower layer MAC functionality to offload tasks from the upper layer MAC. This functionality includes encryption/decryption engines and a CRC checker/inserter.

Fujitsu provides the BSP and device drivers for the supported operating systems, as well as the RTOS wrapper, thus simplifying the porting of the complete software suite to any operating system supported by Fujitsu. Fujitsu's 802.16 upper layer MAC can also be replaced with a third-party component. Fujitsu provides the full API and interface specifications to enable third parties to develop upper layer MAC components. Fujitsu also provides the PSAP/LMAC firmware for base station and subscriber station applications. The upper layer MAC, coupled with the PSAP/LMAC firmware, make up the complete 802.16 protocol stack.

Certification and Compliance

Fujitsu has designed the MB87M3550 wireless MAN SoC to comply with the IEEE 802.16-2004 standard and intends to certify systems according to WiMAX profiles.

The Fujitsu WiMAX 802.16-2004 SoC Base Station or Subscriber Station Management

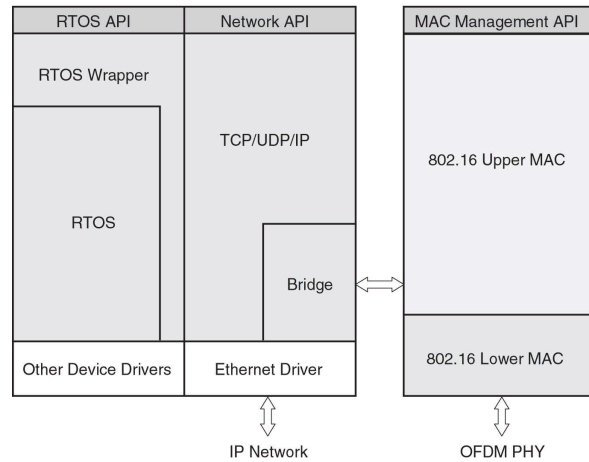

Figure 4 - Fujitsu Software Architecture

More information on the IEEE 802.16 standard for broadband wireless access and the WiMAX Forum is available at www.wimaxforum.org and www.ieee802.org/16.

For more information on Fujitsu's broadband wireless SoC, please address e-mail to inquiry.bwa@fma.fujitsu.com. WiMAX Forum is a trademark of the WiMAX Forum.

FUJITSU MICROELECTRONICS AMERICA, INC.

Corporate Headquarters
 1250 E. Arques Ave. Sunnyvale, CA 94088-3470
 Tel: (800) 866-8608 Fax: (408) 737-5999
 E-mail: inquiry@fma.fujitsu.com Web Site: <http://www.us.fujitsu.com/micro>