

# MB86H51 Full HD H.264 Codec

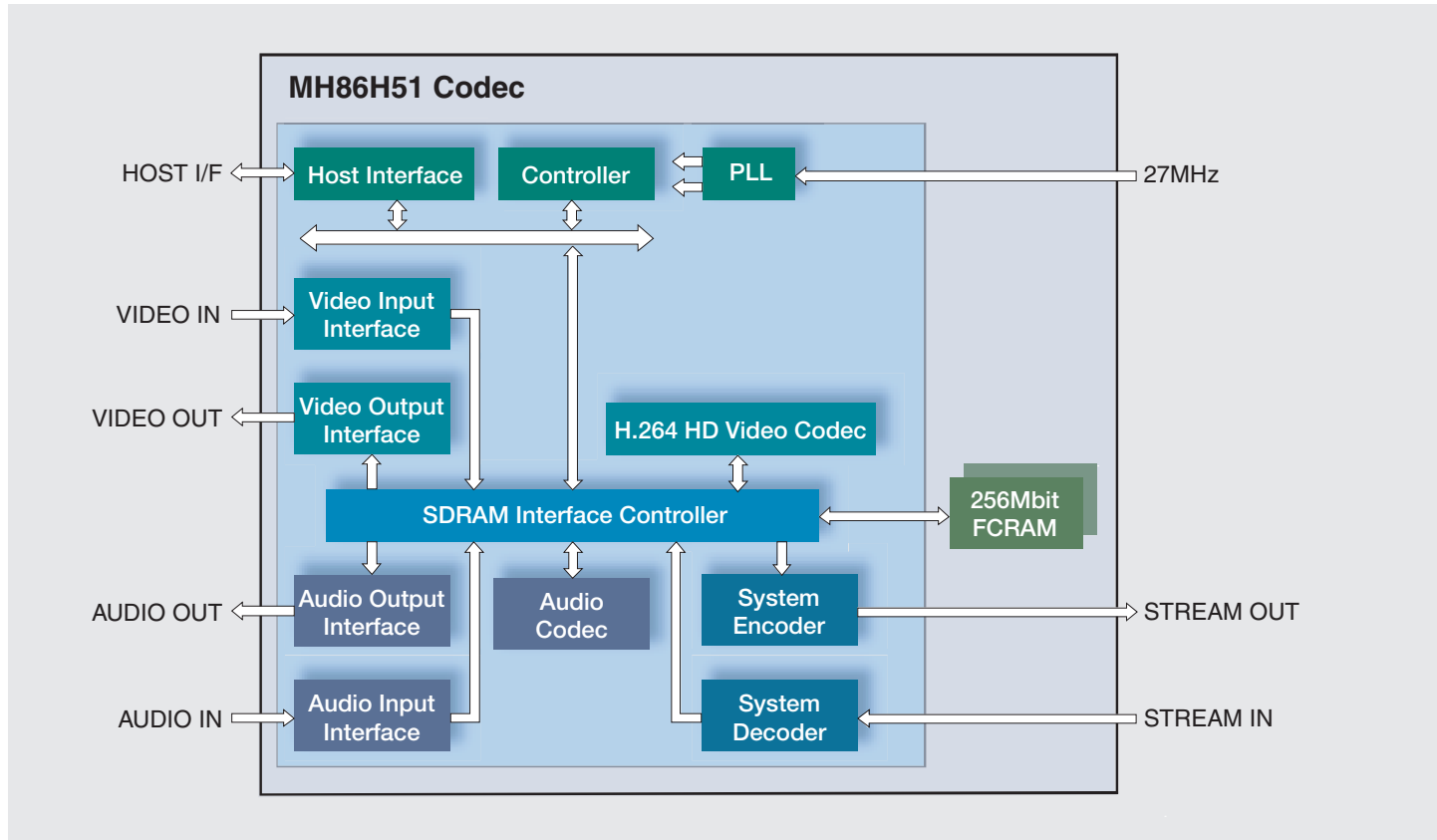

## ▶ Introduction

The Fujitsu MB86H51 can compress and decompress full High-Definition (HD) video (1,920 dots x 1,080 lines) in the H.264 format in real time.

This chip is an enhancement of Fujitsu's MB87H50 (1,440 dots X 1,080 lines) that is currently being mass-produced and shipped. Using proprietary video compression

algorithms from Fujitsu Laboratories Ltd. to reduce the processing burden, while leveraging embedded memory technologies from Fujitsu Limited to enable compactness and low power consumption, Fujitsu's new chip is the industry's first full HD H.264 high-profile LSI with memory in one package.

## ▶ Applications

- Video Cameras
- Mobile Digital Broadcasts
- Next-Generation DVDs for HDTV
- Web Delivery of Digital TV Broadcasts
- Mobile Video Players
- Hard Disk Recorders
- Internet Broadcasts (VoD)
- IPTV Phones
- Mobile TV Phones

# MB86H51 Full HD H.264 Codec

## ► Features

### **Embedded Memory Enables Compactness and Low Power Consumption**

This LSI contains two blocks of 256 Megabit memory (FCRAM) in the same System in Package (SiP), and utilizes an optimized LSI design to reduce the size and lower the power consumption.

### **Real-Time Compression and Decompression of HDTV Video and Audio**

Real-time H.264 format video compression requires more than 10 times the data processing than was necessary for previous formats. By realizing further high-speed processing, Fujitsu's new chip can support H.264 High Profile Level 4.0. Also, with this new chip audio is compressed and decompressed in real time by utilizing formats such as MPEG-1 Audio Layer2.

### **Proprietary Technologies for Compression and High-Quality Video**

This chip utilizes a proprietary algorithm developed by Fujitsu Laboratories that automatically applies less compression to areas in the image where compression artifacts are most noticeable to human vision, such as human faces or slow-moving objects, and greater compression to other areas. Thus, high image quality for the critical zones is maximized. This feature also makes it possible for the image size to be reduced less than to half that of the MPEG-2 format with equivalent image quality.

## ► Specifications

<b>Video</b>	<i>Spec</i>	H.264 High Profile / Level 4.0 Half-duplex Codec
	<i>Resolution</i>	1920 x 1080 x 60i/50i, 1440 x 1080 x 60i/50i, 1280 x 720 x 60p/50p, 720 x 480 x 60i, 720 x 576 x 50i
	<i>Bit Rate</i>	20Mbps (max.)
	<i>Interface</i>	SMPTE 274M / SMPTE 296M-2001, ITU-R BT.656
<b>Audio</b>	<i>Format</i>	MPEG-1 Audio Layer 2, MPEG-2 AAC (LC profile), Linear PCM, Dolby® Digital (AC-3) <sup>1</sup>
	<i>Channels</i>	2 channels
	<i>Interface</i>	LR serial
<b>System</b>	<i>Format</i>	MPEG-2 TS CBR / VBR
	<i>Stream Interface</i>	8-bit parallel or serial
<b>Host Interface</b>		General 16-bit interface
<b>Input Clock</b>		27MHz
<b>Operating Frequency</b>		27MHz, 108MHz (memory only: 135MHz)
<b>Power Consumption</b>		750mW (typ., 1.2V, 1920 x 1080 x 60i at encoding [including Memory])
<b>Package</b>		FBGA 650pin 15mm square SiP (Ball pitch 0.5mm)
<b>Memory</b>		256Mbit FCRAM x 2

<sup>1</sup>Dolby is a registered trademark of Dolby Laboratories.

## FUJITSU MICROELECTRONICS AMERICA, INC.

Corporate Headquarters  
1250 E. Arques Avenue, M/S 333, Sunnyvale, CA 94085-5401  
Tel: (800) 866-8608 Fax: (408) 737-5999  
E-mail: inquiry@fma.fujitsu.com Web Site: <http://us.fujitsu.com/micro>

© 2007 Fujitsu Microelectronics America, Inc.  
All company and product names are trademarks or registered trademarks of their respective owners.  
Printed in the U.S.A. H264-FS-21273-10/2007