

# Fixed and Mobile WiMAX Overview

**Reza Golshan**

**Director of System ASIC Development  
Fujitsu Microelectronics America, Inc.**

<http://us.fujitsu.com/wimax>

# Scope of Presentation



- Broadband Wireless Access
- Overview of 802.16 Standards & Features
- OFDM Basics
- Overview of WiMAX
  - WiMAX Forum
  - Vision & Benefits
  - Certification
  - Applications
- Conclusion / Q&A

- Business and residential customers demand:
  - Data
  - Voice
  - Video distribution
  - Real-time videoconferencing
- Service providers need new value-added services such as:
  - Video on Demand (VOD)
  - Mobile video telephony
  - Online gaming
  - VoIP
  - TV broadcasting
- The “last mile”
  - Fast local connection to network
- Broadband technologies can be fixed, limited mobility or mobile

# Market Segments for Wireless Access

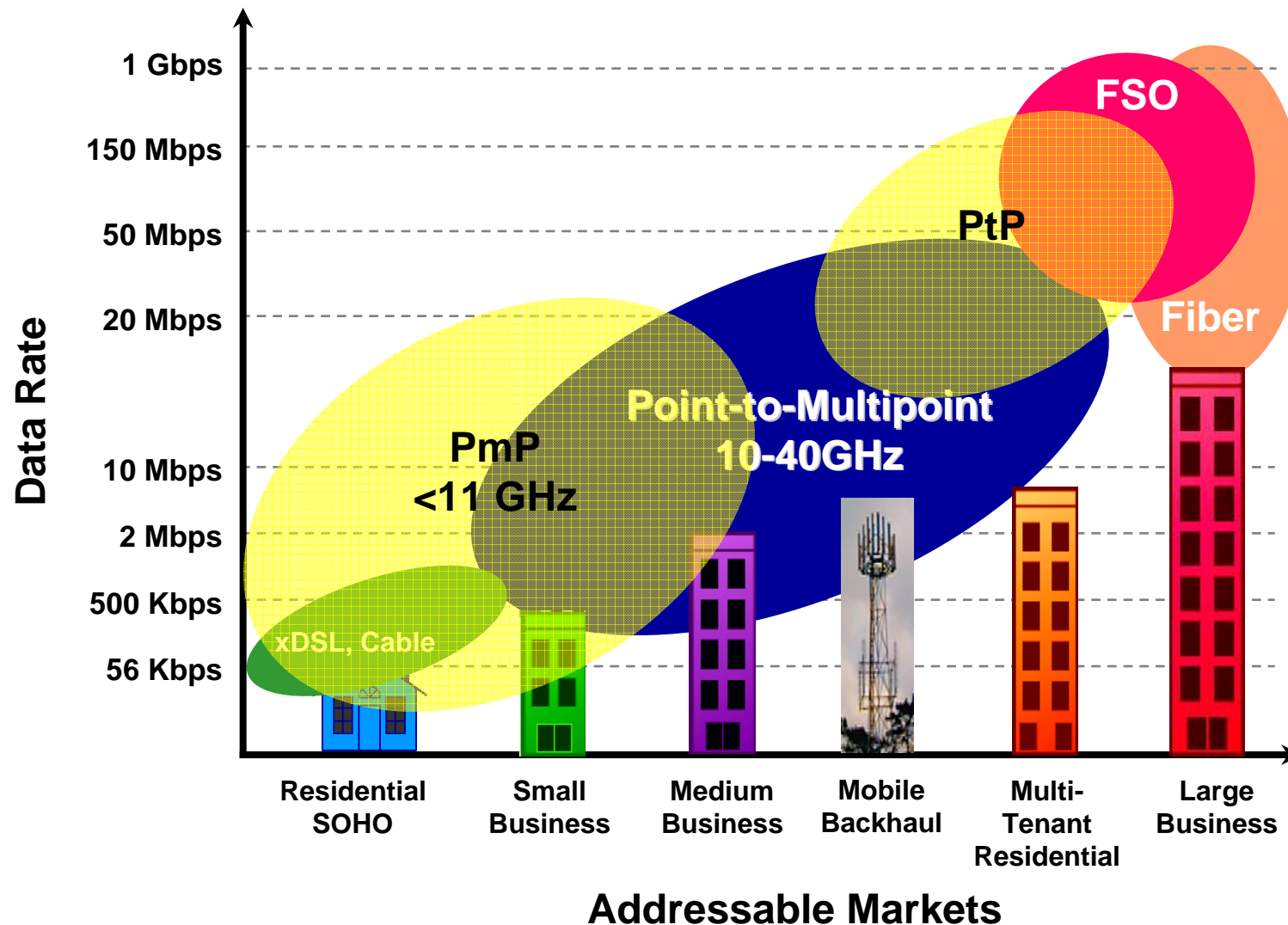

# Global Wireless Standards

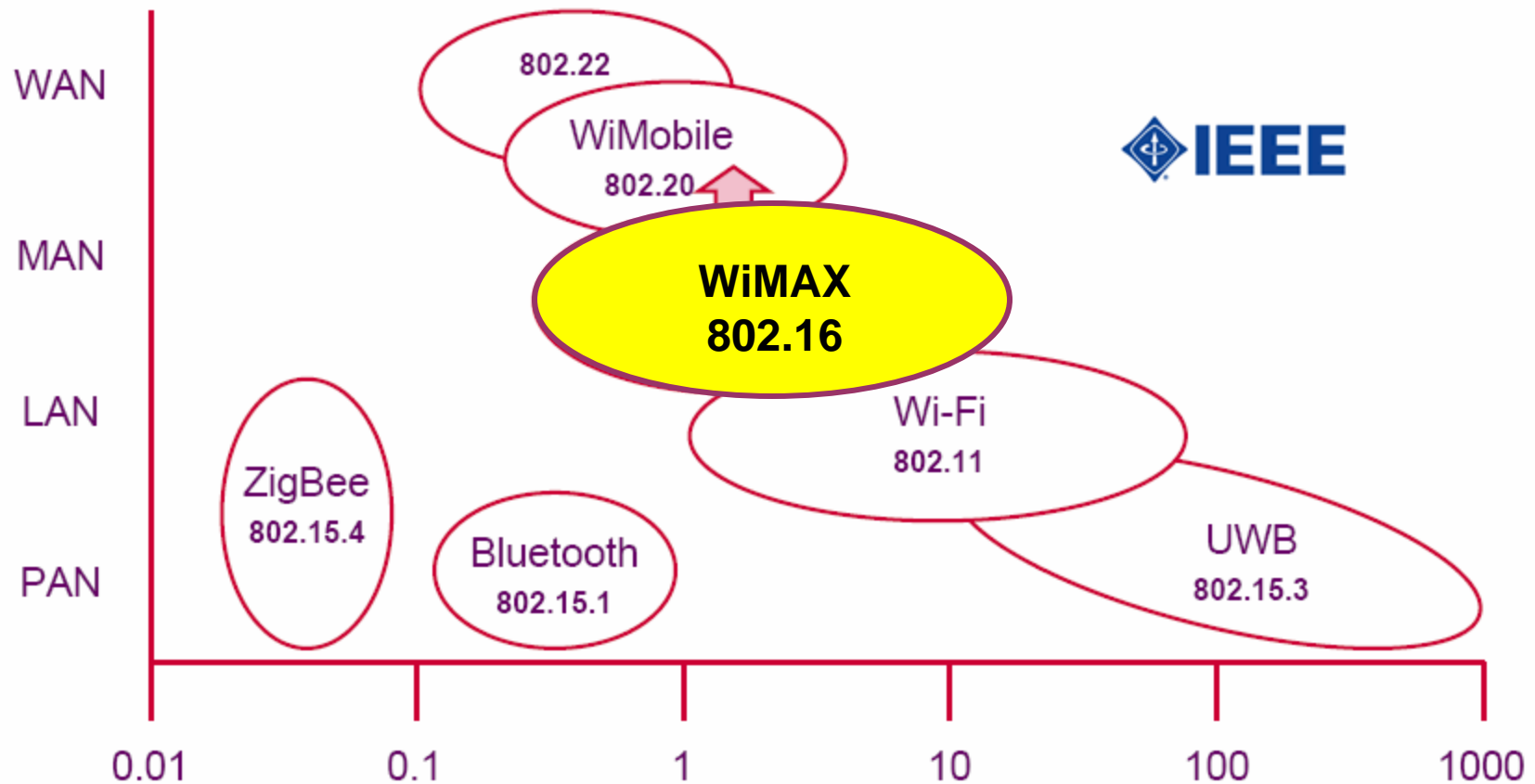

# 802.16 Standards Evolution

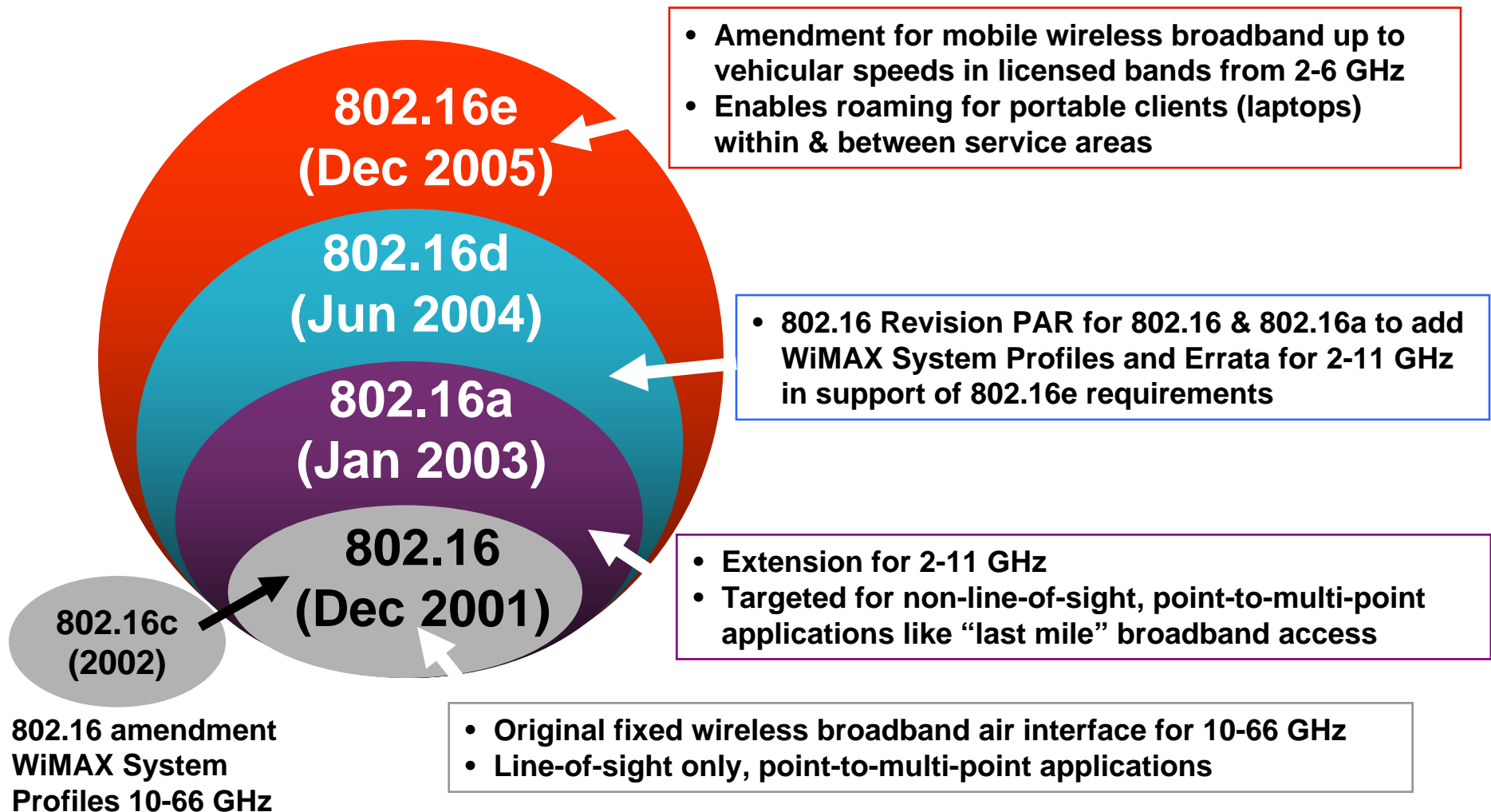

# 802.16 Layer Characteristics

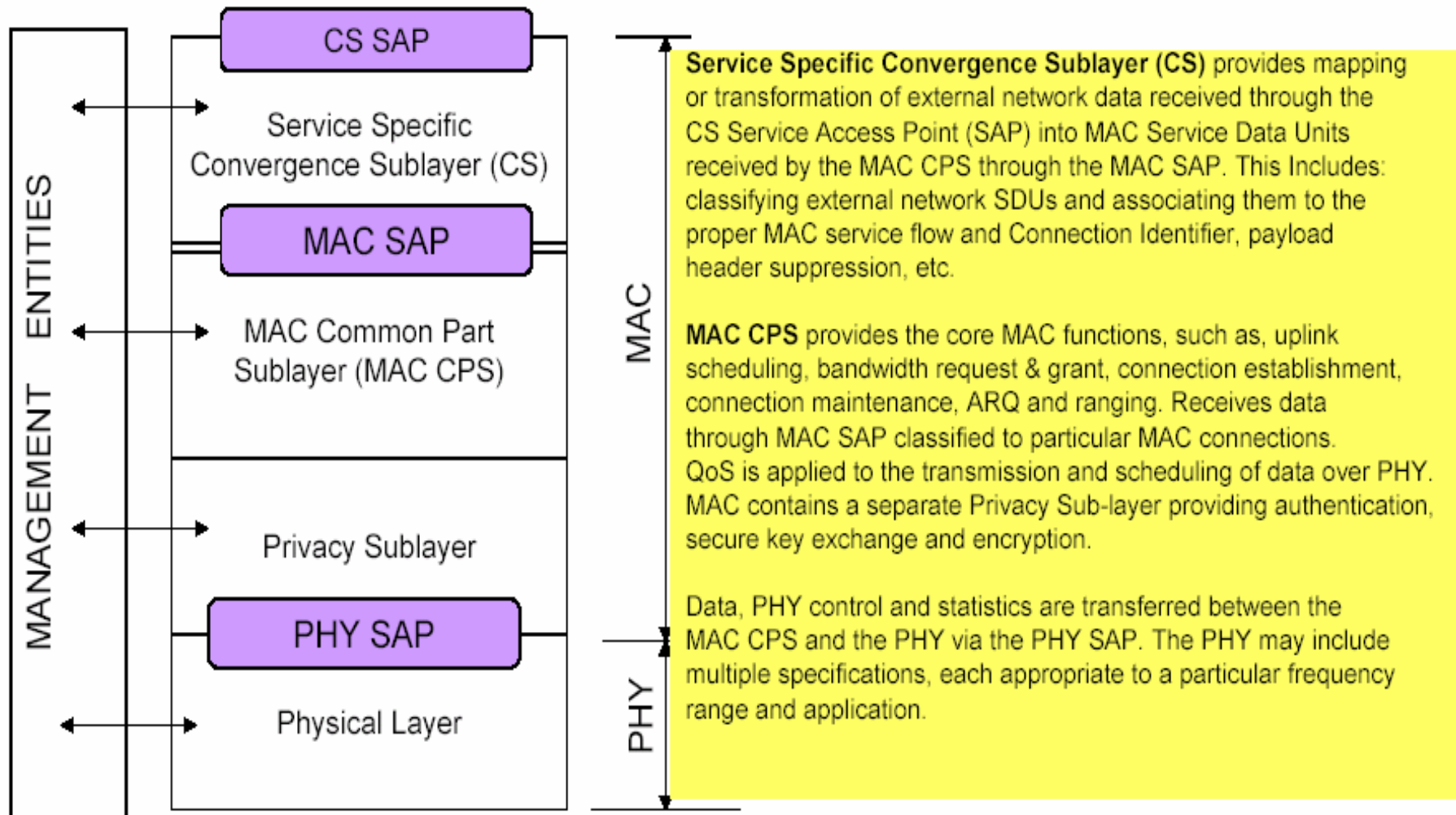

# 802.16 General Characteristics (1)



- Four physical layers (SC, SCa, OFDM, OFDMA)
  - Wireless Metropolitan Area Networks operation in 2-11 GHz spectrum
  - Non-line-of-sight (NLOS) operation designed to address multi-path  
Eliminates need for directional LOS propagation
  - Greater range and higher data rates
- Multiple options for:
  - Flexible channel bandwidths from 1.75 to 20MHz
  - Flexible frame lengths: frame sizes ranging from 2.5 to 20ms
  - Duplexing modes: Time Division Duplex (TDD) and Frequency Division Duplex (FDD)
  - Flexible channel coding & FEC
- Support for multiple antenna technology
  - Adaptive and smart antennas (AAS)
  - TX diversity (STC)
  - Beamforming and spatial multiplexing (MIMO)

## 802.16 General Characteristics (2)



- Link adaptation (per subscriber, burst by burst, uplink and downlink)
  - Adaptive Modulation and Coding BPSK to QAM64 across all channel bandwidths
  - Trade off capacity and robustness in real time
  - Adaptive burst profiles dynamically assigned modulation and FEC for each burst
- Point-to-multipoint topology, with mesh extensions
- Protocol independent supporting ATM and packet-based protocols
- ***True*** Quality of Service (QoS) supports multiple services simultaneously, with different QoS priorities
- Scalable system capacity allows more efficient use of available spectrum than other wireless technologies
- Supports both licensed and licensed-exempt frequencies
- Supports a variety of services such as IP, voice over IP and streaming video
- Bandwidth on demand (frame by frame)
- Comprehensive and extensible security (DES and AES CCM)

# Why Is the Focus on OFDM?



- The OFDM signal is able to support NLOS performance while maintaining a high level of spectral efficiency, maximizing the available spectrum
- Superior NLOS performance enables significant equalizer design simplification
- Supports operation in multi-path propagation environments
- Scalable bandwidths provide flexibility and potentially reduce capital expense

# OFDM Basic Concepts

- A conventional transmission uses only a single carrier, which is modulated with all the data to be sent
- OFDM is a multi-carrier amplitude modulation scheme that transmits data over a number of orthogonal sub-carriers
- OFDM breaks the data into small chunks, allocating each sub-data stream to a sub-carrier
- The data is sent in parallel orthogonal sub-carriers

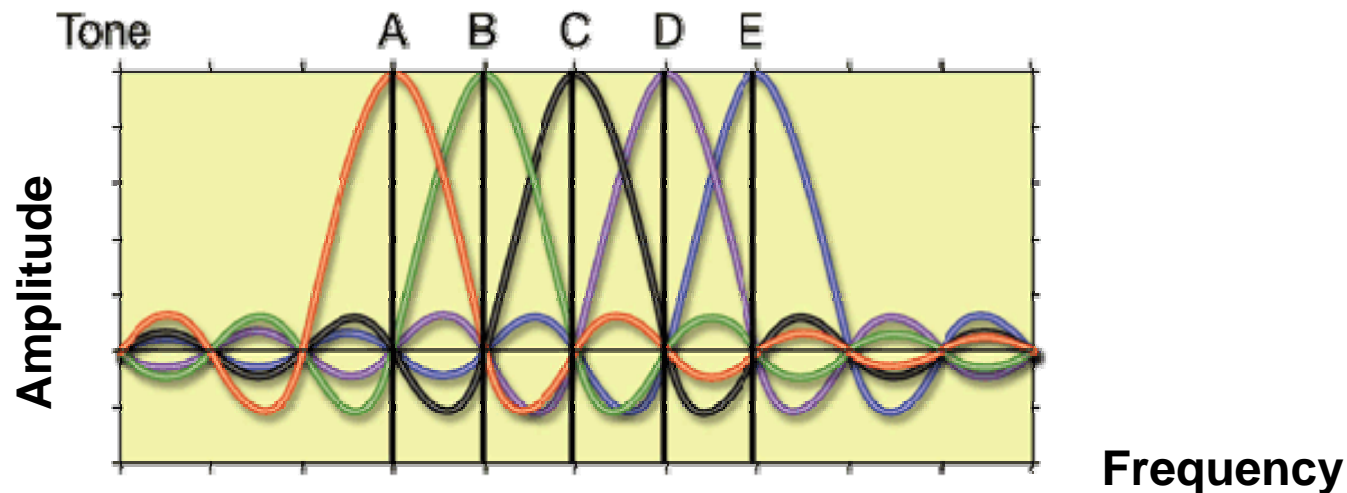

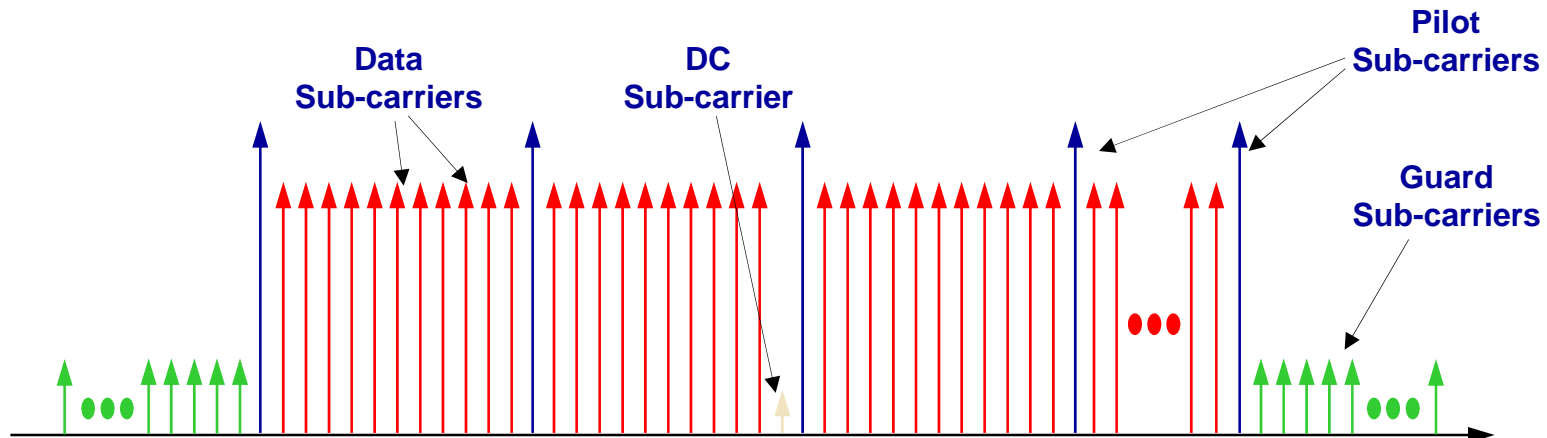

## ■ OFDM Sub-carrier Organization

- Data Sub-carriers
  - Transport BPSK, QPSK, 16QAM, 64QAM symbols
- Pilot Sub-carriers
  - Transport known pilot symbol sequence (frequently at an elevated power level) to permit channel estimation and coherent demodulation at receiver
- Guard Sub-carriers
  - Suppressed – permits spectrum shaping
- DC Sub-carrier
  - Frequently suppressed to support direct-conversion receivers

# OFDM and OFDMA

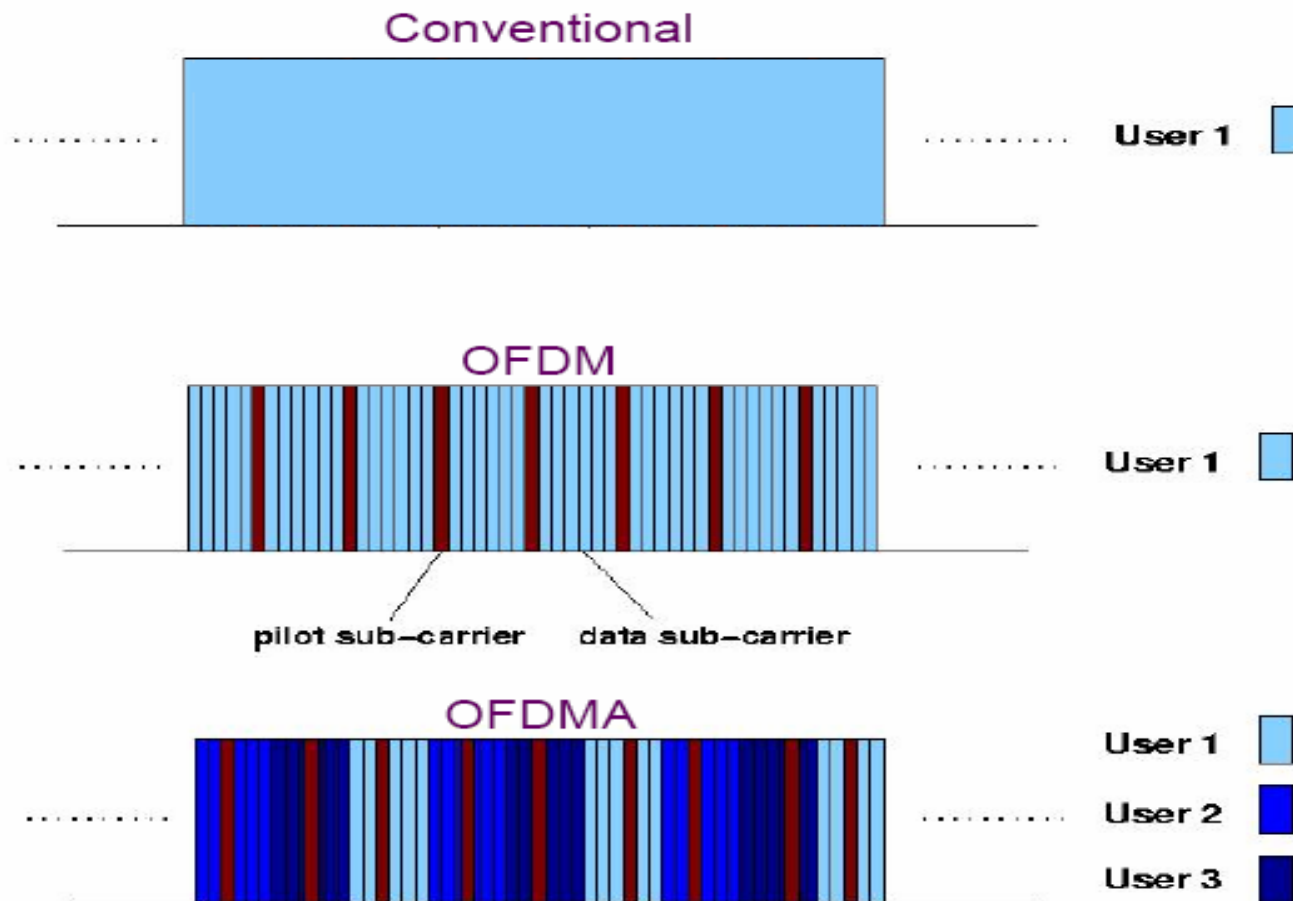

**Available data sub-carriers divided into N contiguous groups**  
**Each sub-channel assigned one data sub-carrier from each group**

# OFDM Transceiver

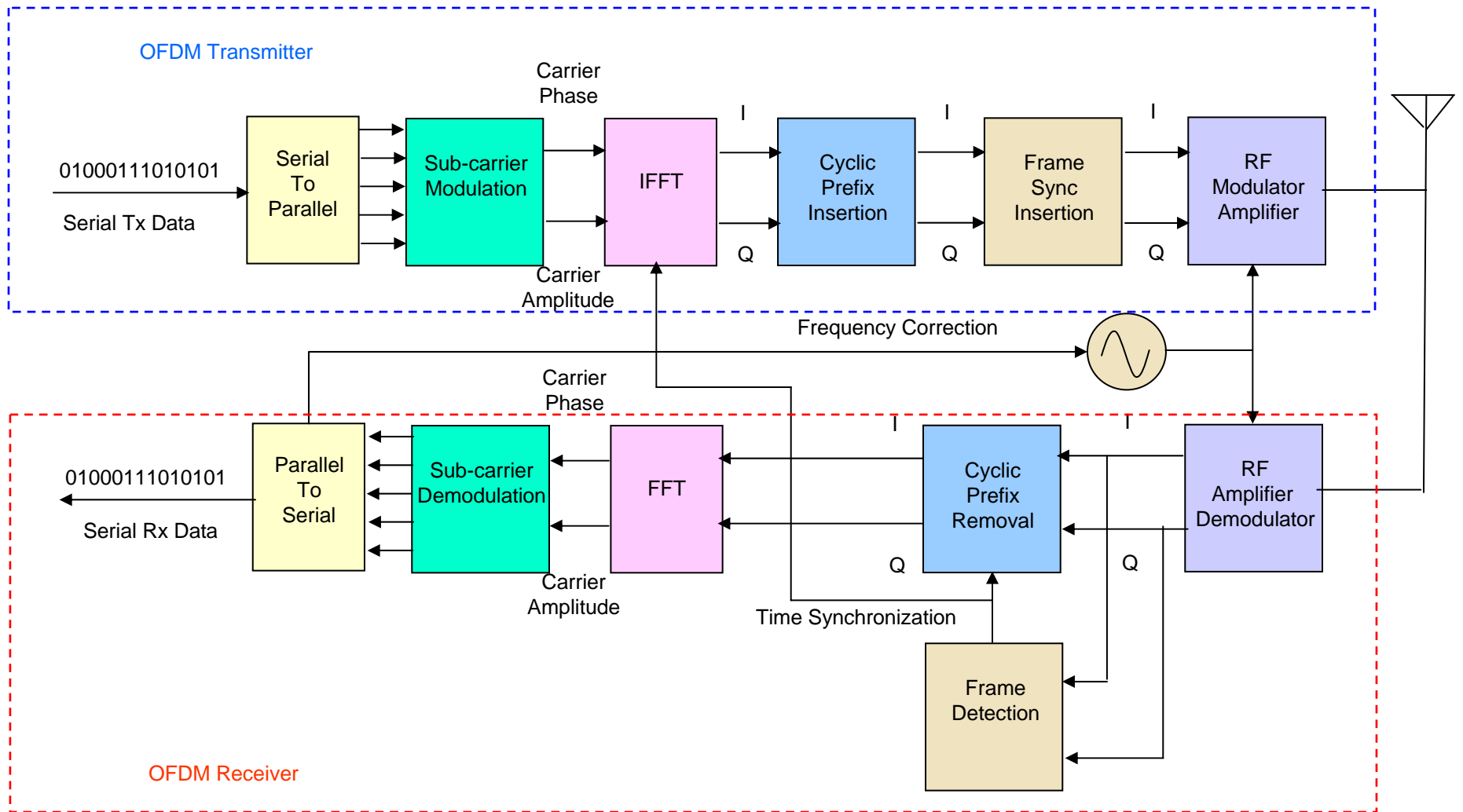

# TDD & FDD Support

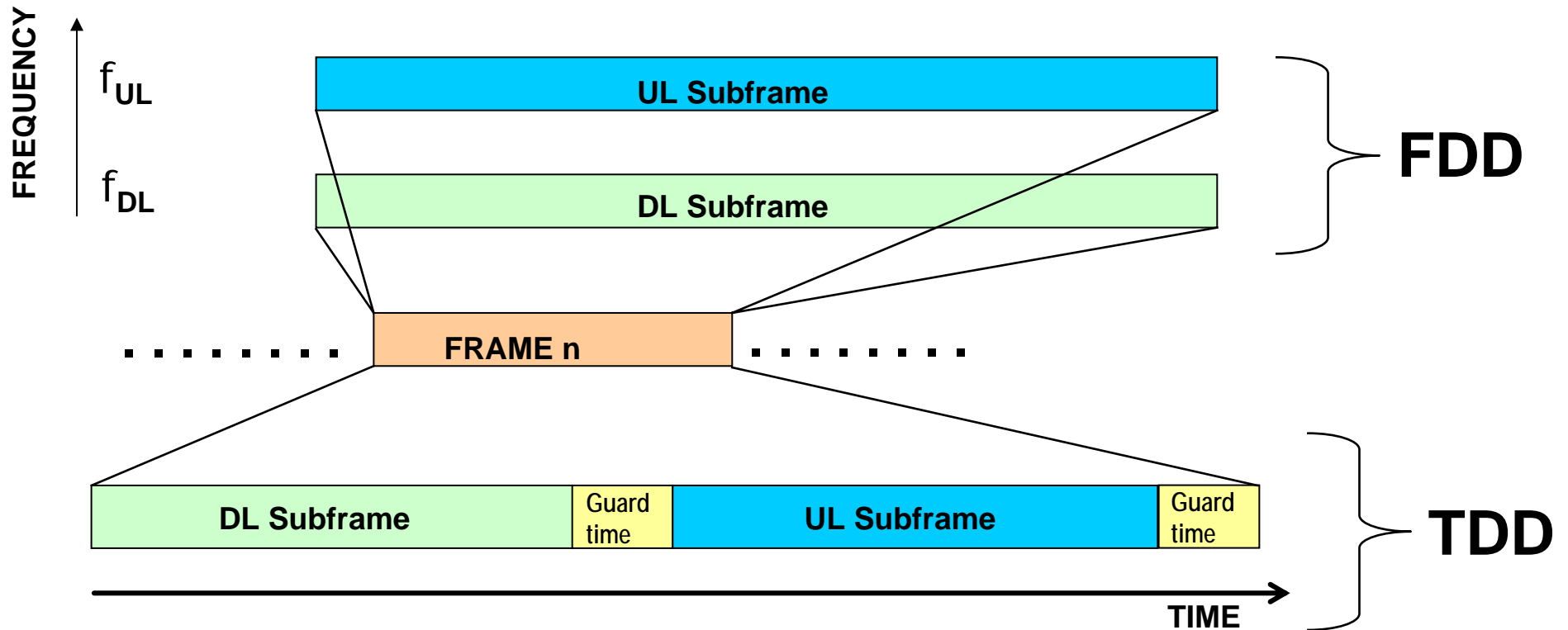

- Time Division Duplex (TDD) and Frequency Division Duplex (FDD) modes
- Frame duration from 2.5 to 20ms
- Channel bandwidths ranging from 1.75 to 20MHz
- Guard times (cyclic prefix) 1/4, 1/8, 1/16 or 1/3

## Modulation changes dynamically to match propagation path

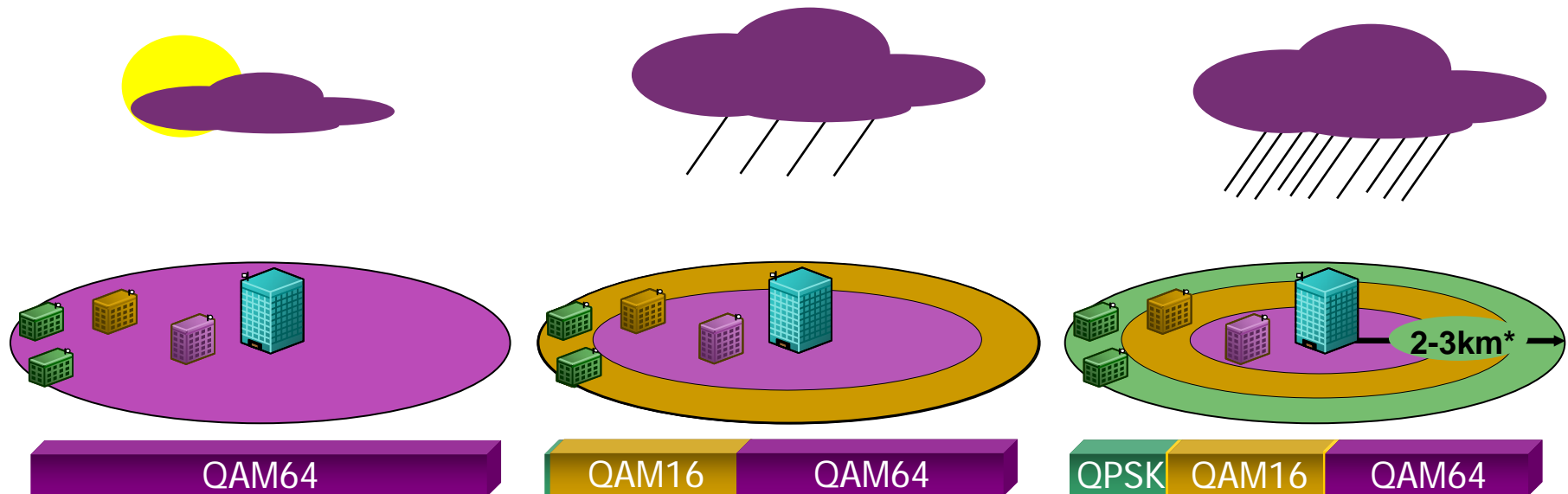

- Adaptive Modulation maximizes both air-link capacity and coverage
- Adaptive TDMA: True bandwidth on demand and variable packet sizes provide differentiated, bursty services to multiple users
- Adaptive TDD: Variable asymmetry in a single broadband channel best matches bandwidth to demand

- BPSK, QPSK, 16QAM and 64QAM
- Concatenated Reed-Solomon/Convolution Code (RS-CC) FEC
- Convolutional Turbo Code (CTC)
  - CTC encoder adopted from DVB-RCT specification – similar performance to 3GPP
- Optional LDPC code under study

# Channel Quality Indicator

- Base Station uses Adaptive Modulation and Coding (AMC) to send data to the subscriber stations to optimize throughput
- A Channel Quality Indicator (CQI) channel is utilized to provide channel-state information from the user terminals to the base station scheduler

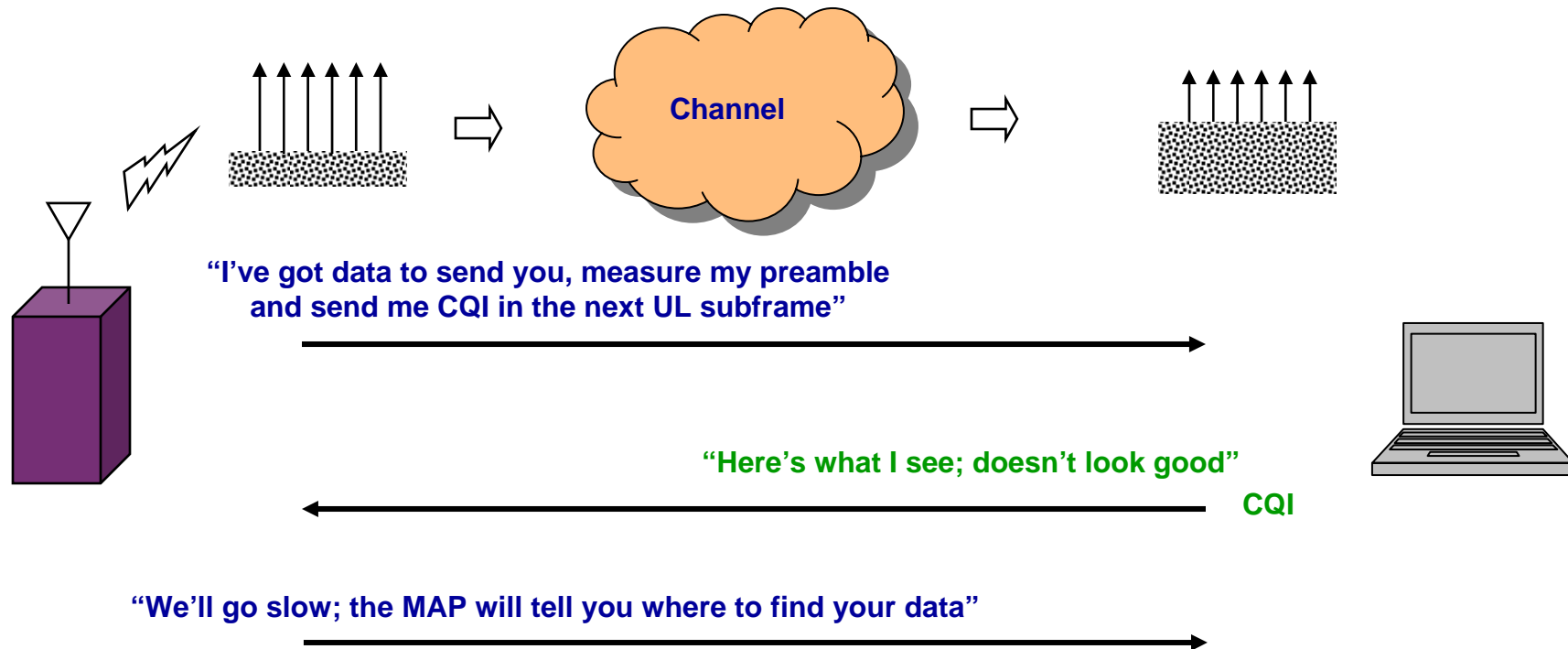

# Frame Structure

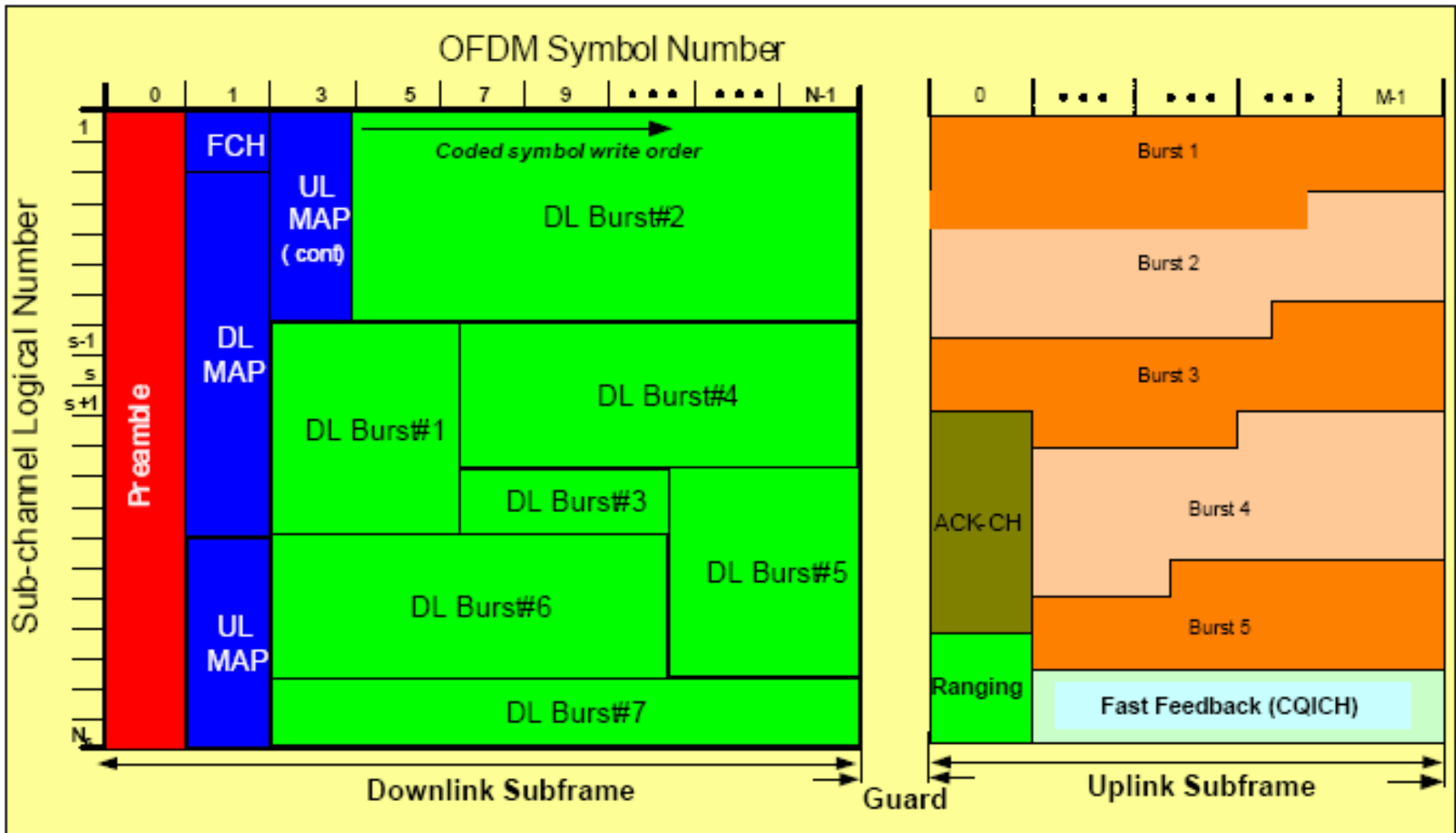

- Beamforming
  - Multiple-antennas transmit weighted signals to improve coverage and capacity
- Transmit Diversity: Space-Time Code (STC)
  - Provides spatial diversity and reduce fade margin
- Spatial Multiplexing (SM)
  - Multiple streams are transmitted over multiple antennas
  - Receiver can have single or multiple antennas. Receiver separates different streams to achieve higher throughput compared to a single antenna
  - Examples: 2x2 MIMO, 1x2 SIMO

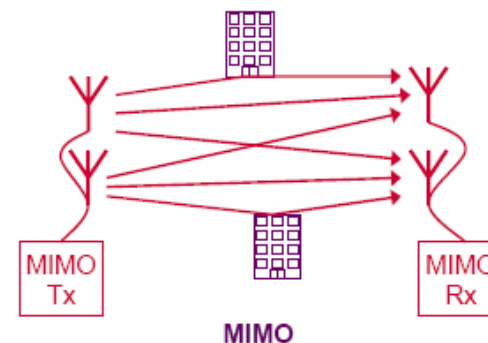

# QoS Support

- QoS is provided via service flows. This is a unidirectional flow of packets with a particular set of QoS parameters
- Base Station and user terminal first establish a unidirectional logical link between the peer MACs called a connection

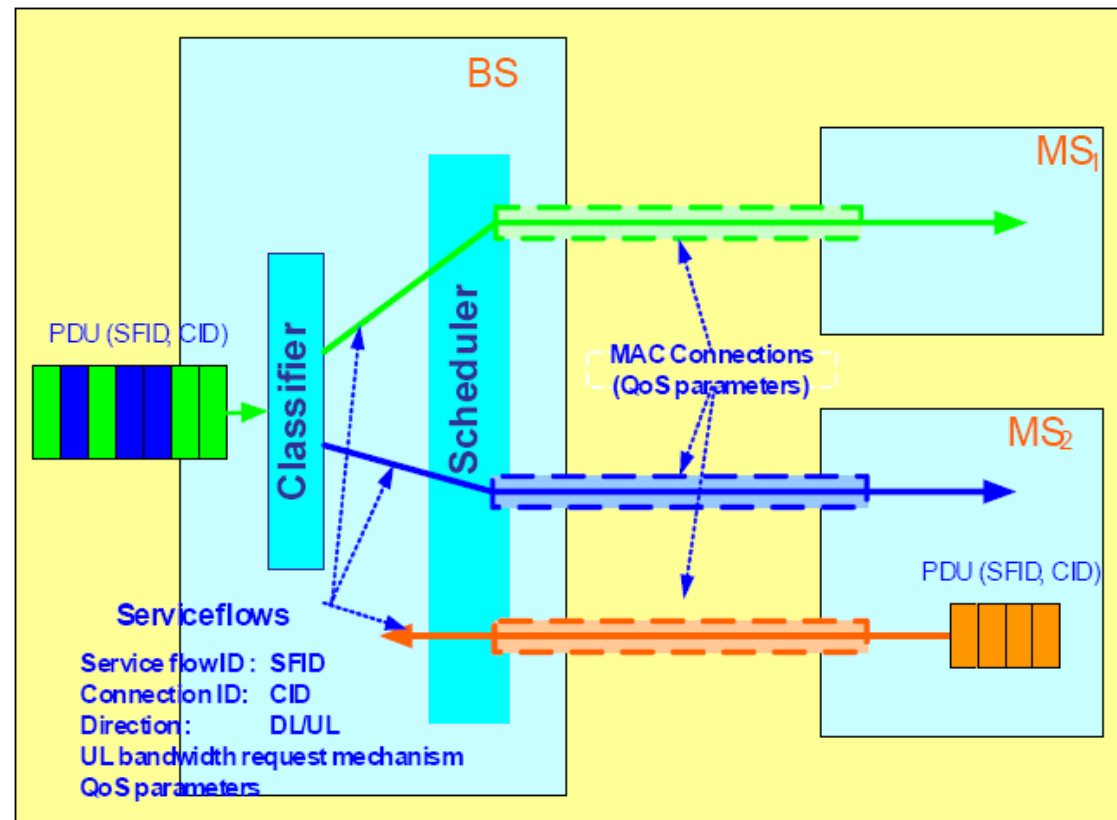

# Hybrid Automatic Repeat-Request (HARQ)



- Self-optimizing and adjusts automatically to channel conditions
  - Adds redundancy only when needed
  - Receiver saves failed transmission attempts to help future decoding (Chase Combining)
  - Every transmission helps to increase the packet success probability
- Enabled by *N*-Channel Stop-and-Wait ARQ
  - Receiver sends an ACK or NAK in response to each transmission

# WiMAX

# What is WiMAX ?



**Worldwide Interoperability for Microwave Access**

# WiMAX Forum Charters



- Industry-led, non-profit corporation
- More than 350 members: Service providers, system vendors, semiconductor suppliers, and eco-system
- To promote a common broadband wireless standard
- To develop reduced scope “profiles” to ease development
- To act as a certification body

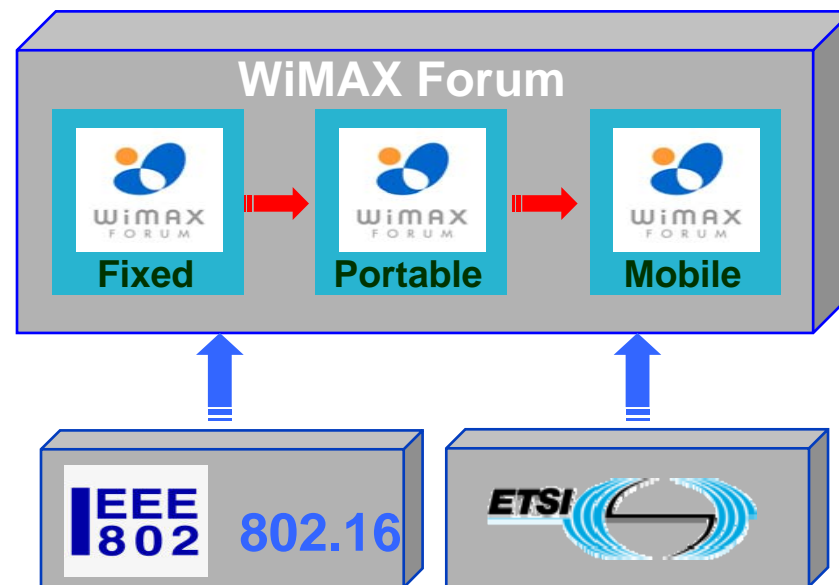

# WiMAX Vision



# WiMAX Benefits



## Pre-Standard: Discrete Components

- Proprietary, vertical solutions
- No volume silicon market

## Post-Standard: Integrated Solution

- Equipment interoperability
- Economies of scale
- Superior price/performance

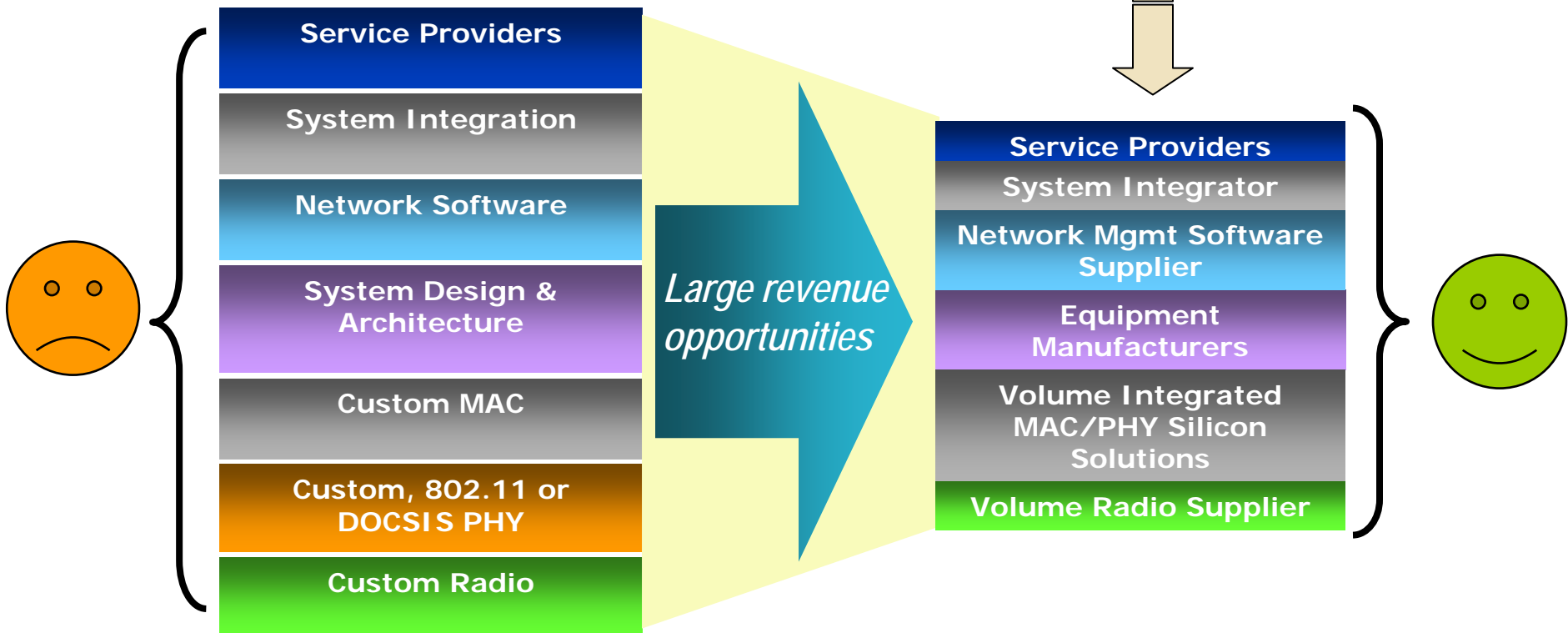
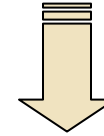

# WiMAX Frequency Bands

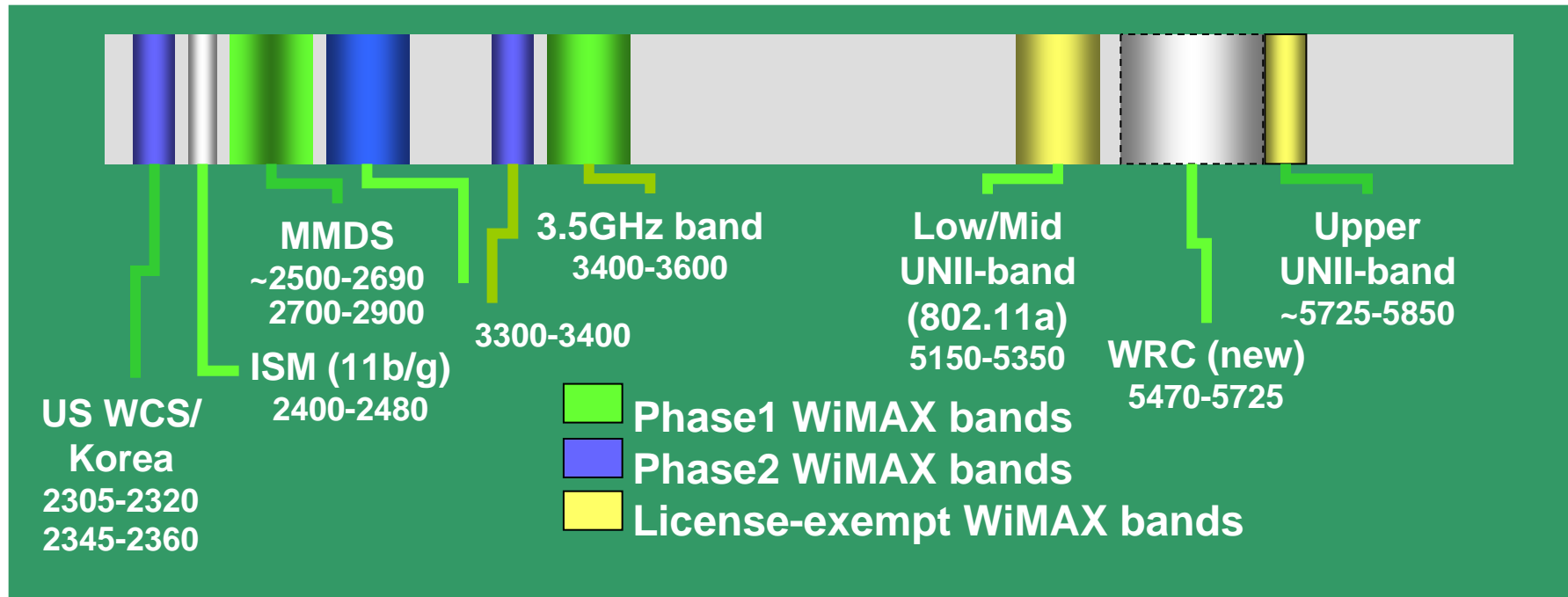

Service	Frequency (GHz)	Description
WCS	2.3	Wireless Communication Service
ISM	2.4 – 2.4	Industrial, Scientific and Medical Bands
MMDS	2.5 – 2.7	Multi-channel Multipoint Distribution Service
International	3.4 – 3.7	Licensed Bands – Europe, Latin America, Asia
	4.8 – 5	Licensed Bands – Japan
UNII	5.15 – 5.35 & 5.75 – 5.85	Licensed-exempt National Information Infrastructure Band
New Spectrum	5.470 – 5.725	FCC NPRM 03-110 Part 15

Note: 4.3GHz (emergency band), 4.9GHz (public safety band)

# WiMAX Certification Process

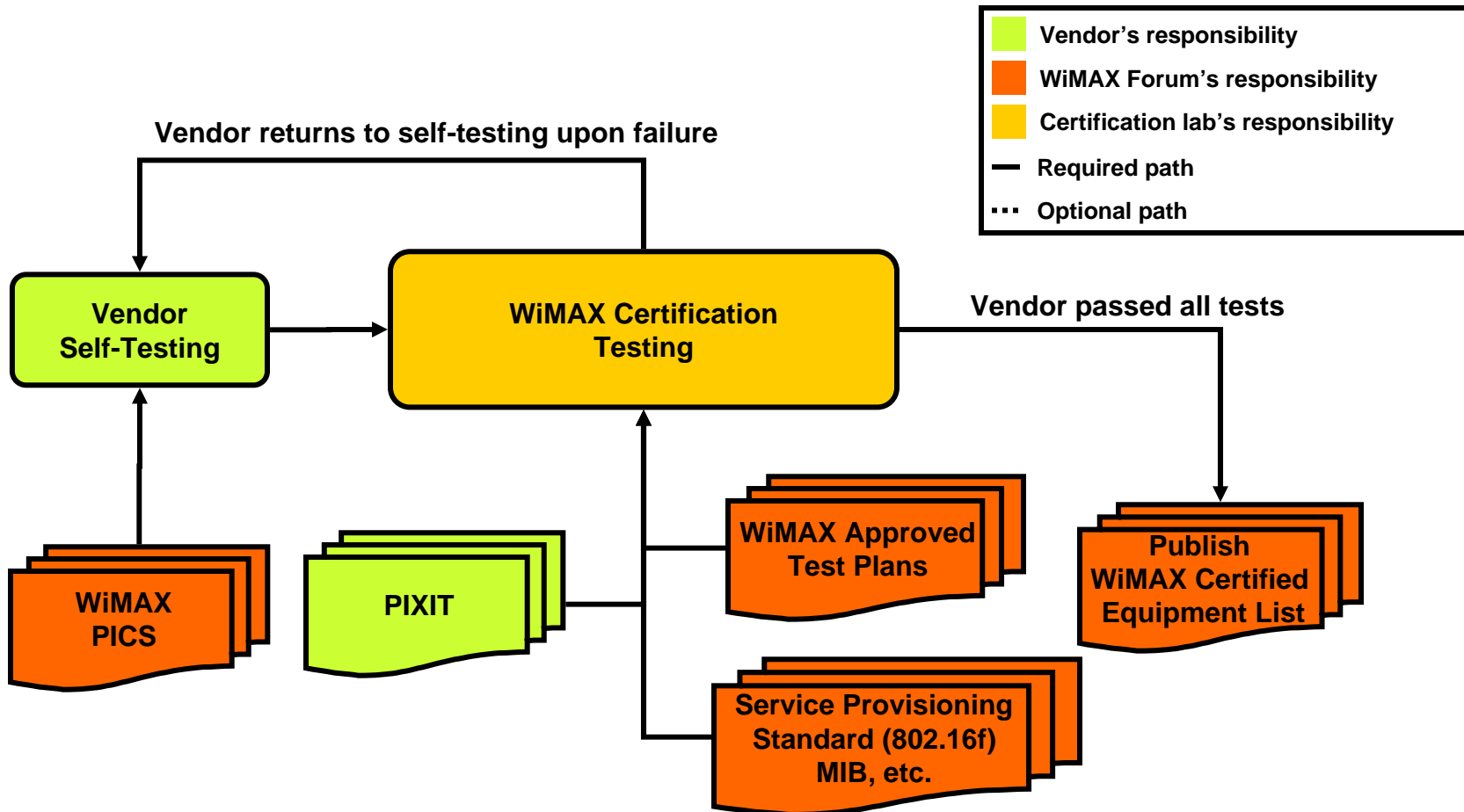

- PICS Proforma: Protocol Implementation Conformance Statement
- TSS & TP: Test Suite Structure and Test Purposes
- ATS: Abstract Test Suite
- Standardized (Protocol) Implementation eXtra Information for Testing

# WiMAX Forum Certification Program



## ■ WiMAX Certification Services

- CETECOM, a WiMAX Forum designated certification laboratory (located in Spain), provides a one-stop service for the certification of WiMAX systems

## ■ Mission

- Evaluate testing options
- Recommend test lab(s) selection
- Manage test lab and vendor relationships
- Manage WiMAX Forum Certification program
- Maintain open process for WiMAX Forum Certification program
- Provides system profiles, PICS, TSS & TP

# What is Certified?



WiMAX certification is for the system, not for components

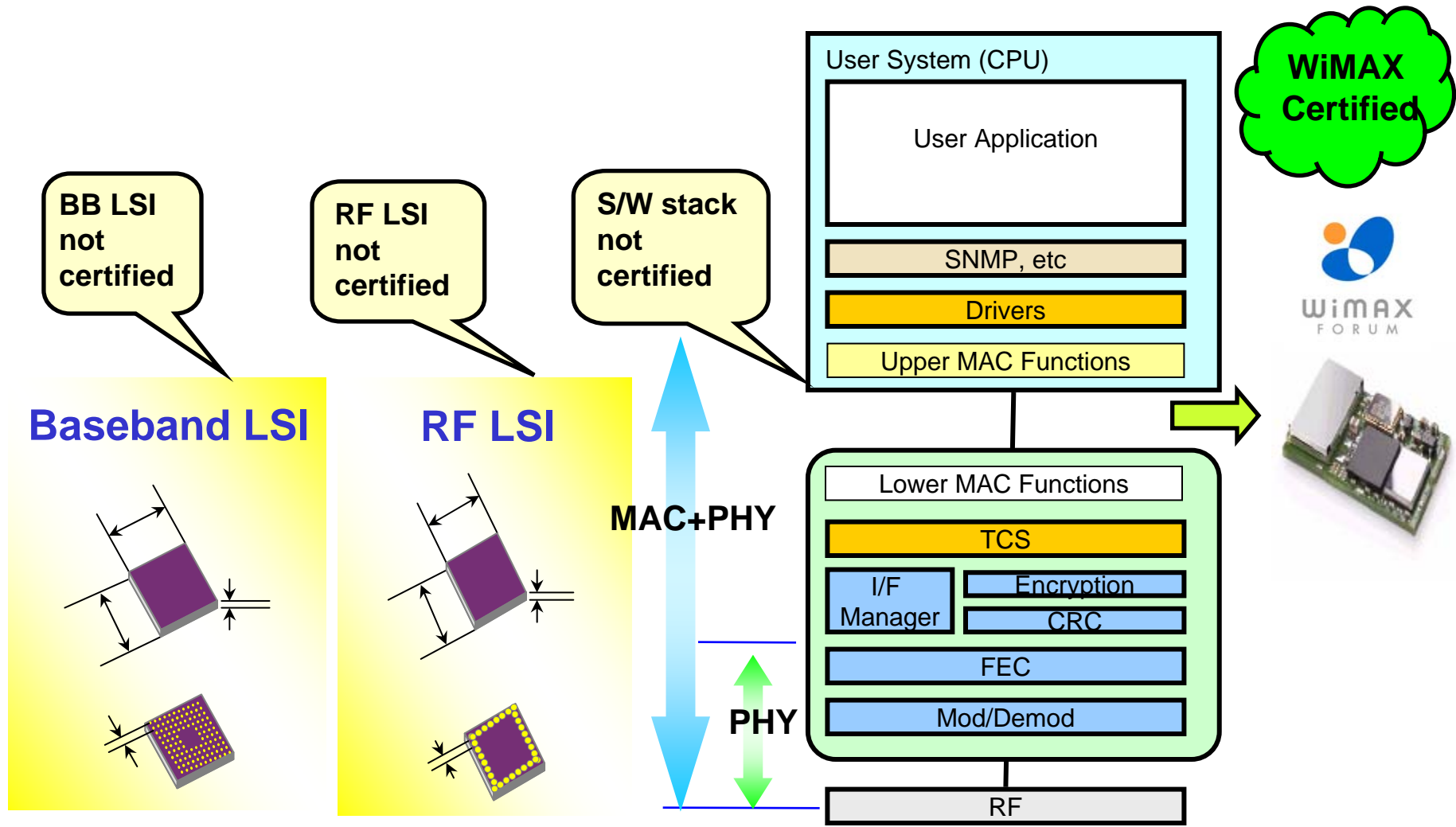

# WiMAX Timeline

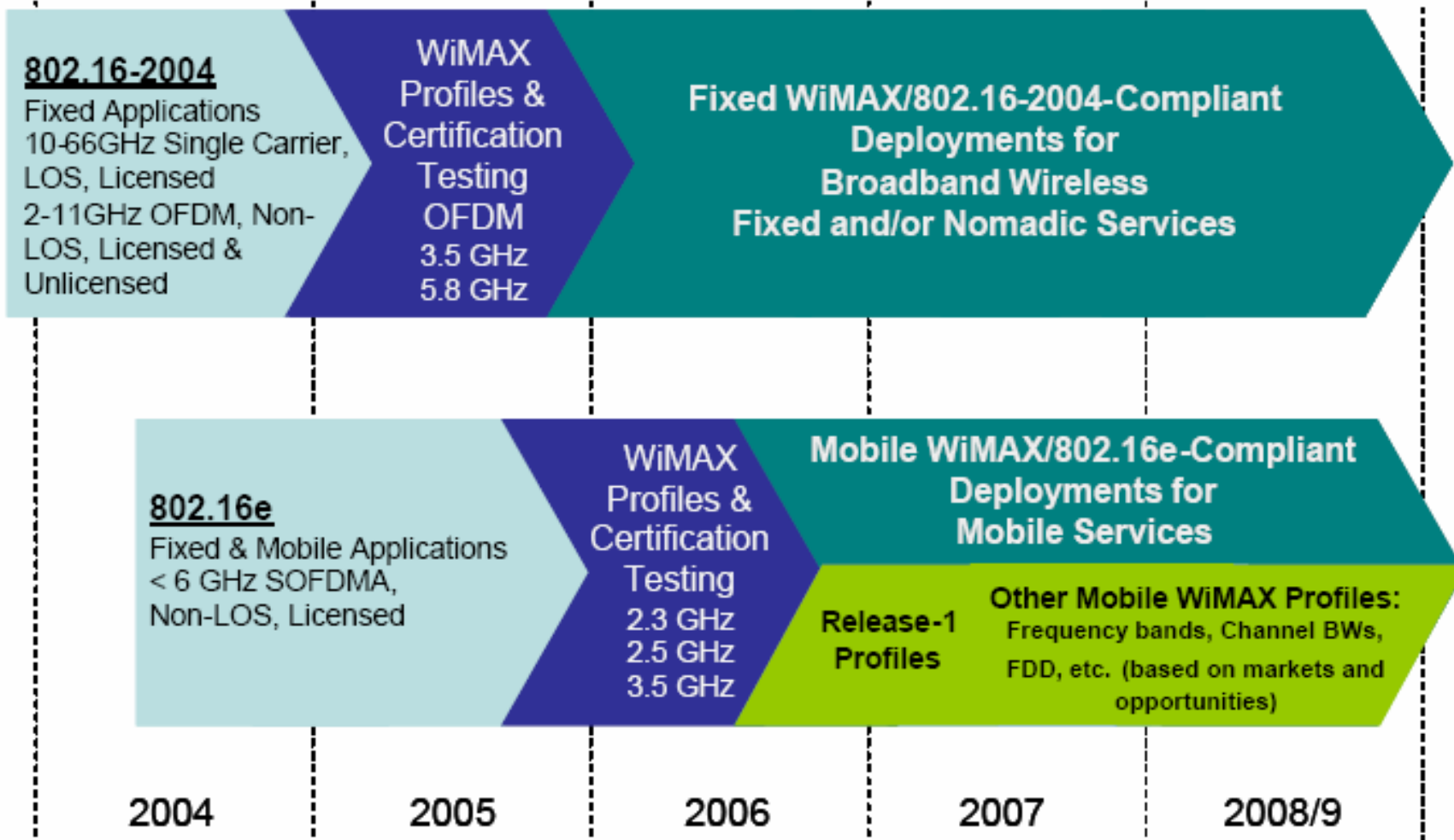

# Fixed - Mobile WiMAX Profiles Selections



Wide Range of Options

IEEE  
802

Wireless MAN

802.16

Sub-set of 802.16 options

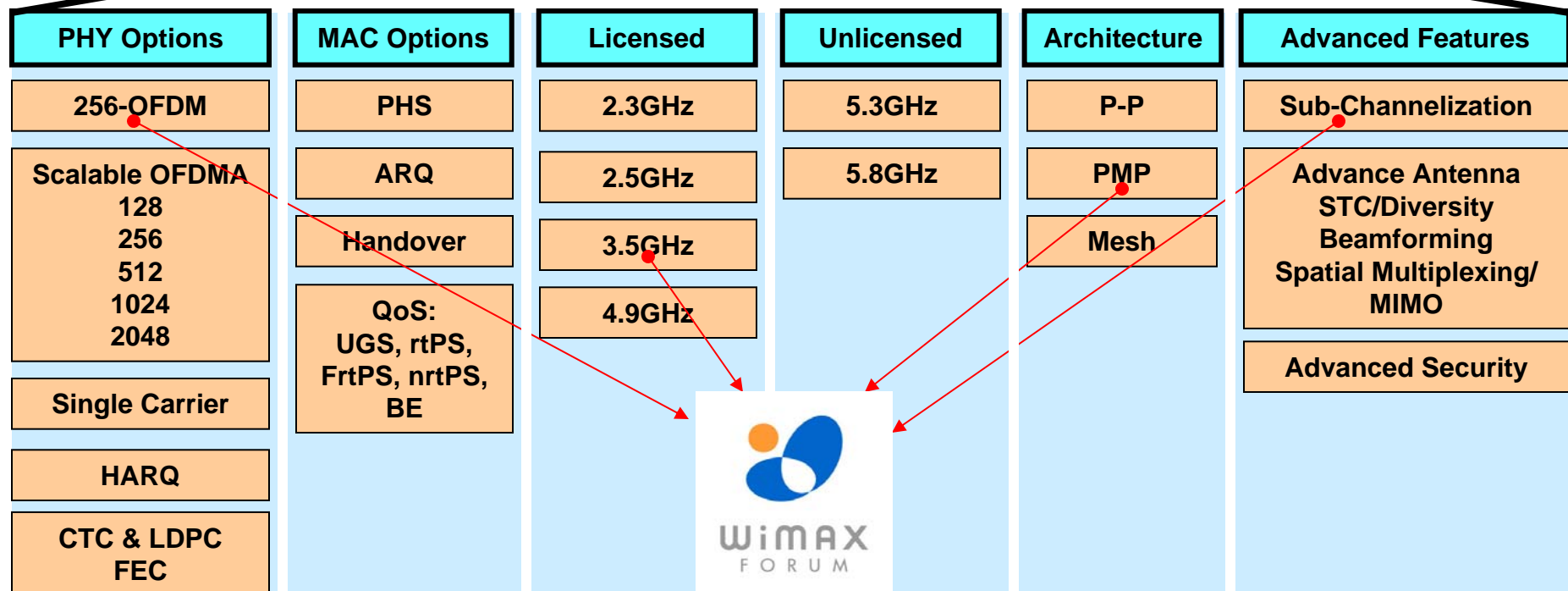

The WiMAX-based applications are related to two different PHY supports: OFDM256 and OFDMA.

# Key Features



Fixed/Nomadic (802.16-2004)	Mobile (802.16e-2005)
<b>256 - OFDM</b> Uplink sub-channelization (optional) Channel BW: up to 10MHz	<b>Scalable OFDMA 128 – 2048</b> Full uplink & downlink sub-channelization Channel BW: up to 10MHz
TDD and FDD support	TDD
Space Timing Coding (optional)	Adaptive antenna systems, Beamforming, Space Timing Coding & Spatial Multiplexing (MIMO)
Per-connection QoS support	QoS support: UGS, rtPS, ErtPS, nrtPS, BE
Automatic Retransmission Request (ARQ)	HARQ
Security and encryption (DES)	<b>AES CCM</b> -Key management protocol -Device / user authentication -Control message protocol -Fast handover support
Coding: Reed-Solomon/Convolution Code (RS-CC) FEC	Coding: CTC and LDPC FEC
Licensed & license-exempt bands	Licensed bands
NA	Mobility management (sleep and idle mode)
NA	<b>Handover (HO)</b> -Hard handover (HHO) -Soft handover (SHO) -Macro diversity handover (MDHO)

# BWA Evolution (Fixed / Portable / Mobile)

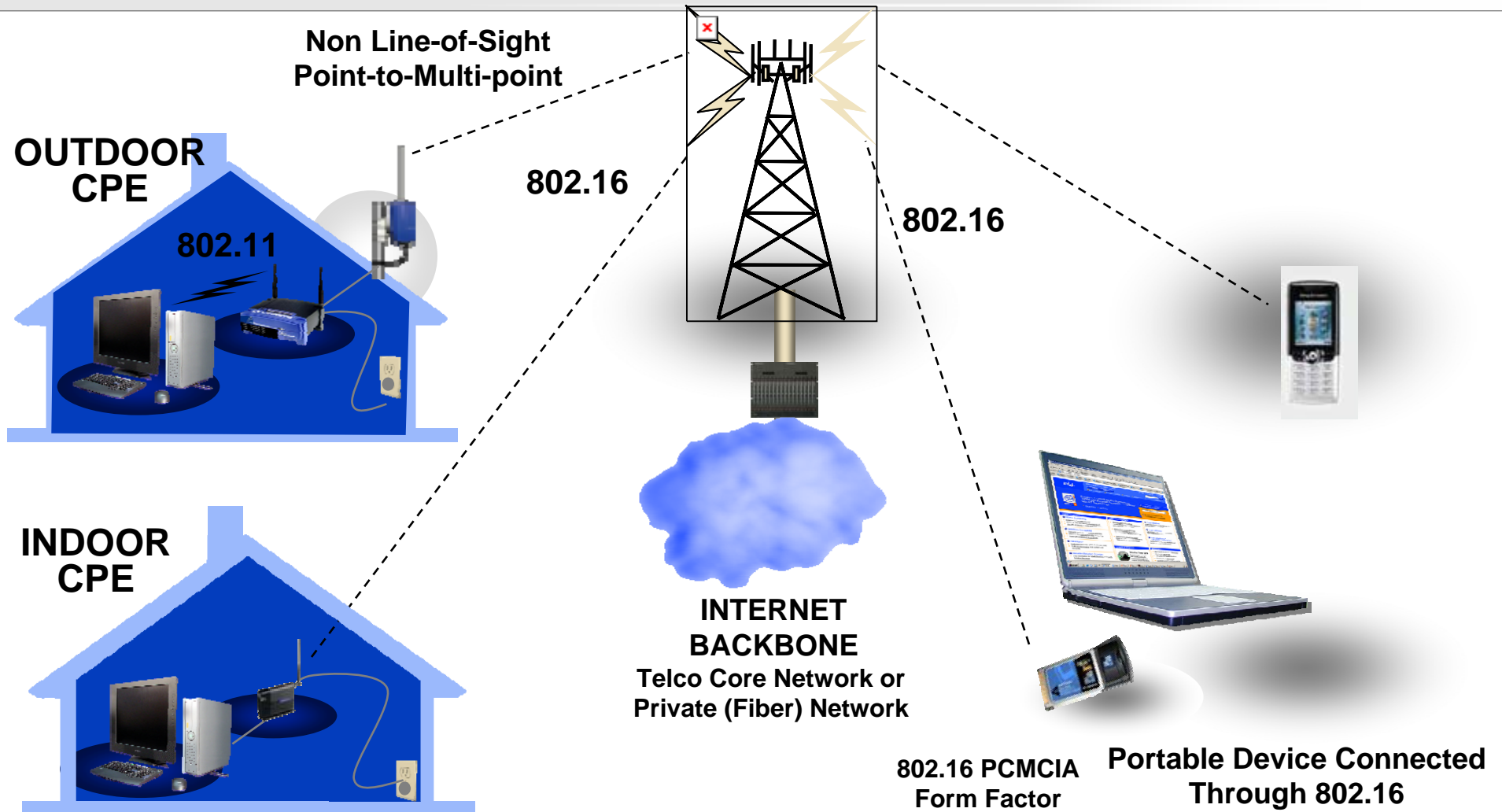

# Vision – Wireless Multimedia Distribution

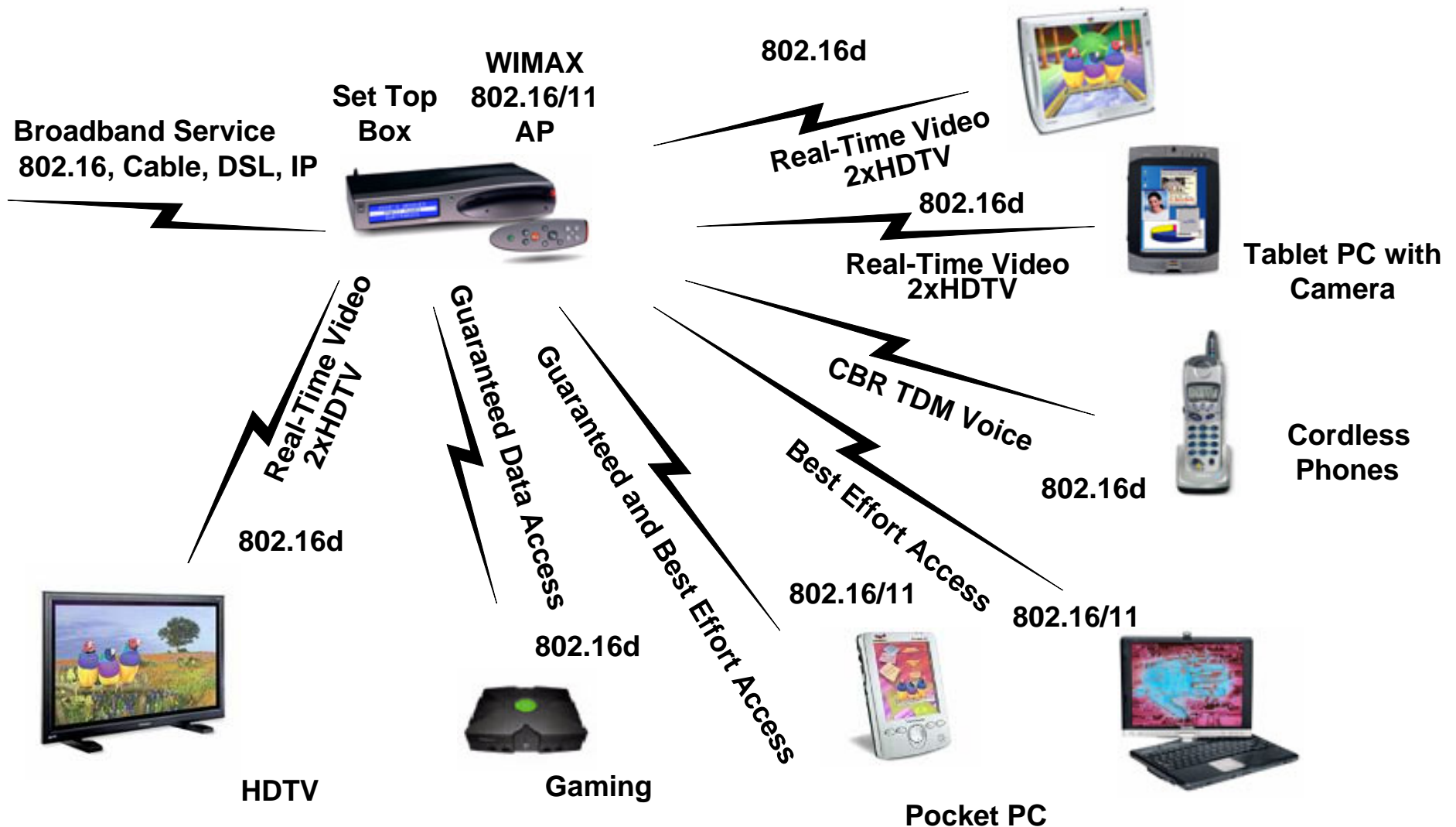

# Other WiMAX Applications



- WSP (Wireless Service Provider) Backhaul
- Banking Networks
- Education Networks
- Hot Zone
- Public Safety
- Rural Connectivity
- Enterprise Private Networks
- Alternative to DSL / Cable
- Cellular Backhaul

- WiMAX, a single technology can deliver fixed, portable & mobile services with scalable bandwidths & higher data rates
- WiMAX is a well-supported, cost-effective, standards-based, flexible, broadband technology that is ready to deliver significant benefits for:
  - Operators in a wide range of markets (enterprise, consumer, emerging, public service)
  - Over a wide range of geographies and demographics (urban, suburban, rural)
- Advantages of WiMAX
  - Large coverage
  - Higher capacity
  - Scalable
  - Faster to implement
  - Performs well in high delay spread environments
  - Supports multiple antenna technologies



**FUJITSU**

**THE POSSIBILITIES ARE INFINITE**