

# MEMORY

CMOS

**2 × 512 K × 16 BIT / 2 × 256 K × 32 BIT**

**SINGLE DATA RATE I/F FCRAM™** (Extended Temp. Version)

Consumer/Embedded Application Specific Memory for SiP

## MB81ES171625/173225-15-X

### ■ DESCRIPTION

The Fujitsu Microelectronics MB81ES171625/173225 is a Fast Cycle Random Access Memory (FCRAM\*) containing 16,777,216 bit memory cells accessible in a 2×512K×16 bit / 2×256K×32 bit format. The MB81ES171625/173225 features a fully synchronous operation referenced to a positive edge clock same as that of SDRAM operation, whereby all operations are synchronized at a clock input which enables high performance and simple user interface coexistence.

The MB81ES171625/173225 is utilized using a Fujitsu Microelectronics advanced FCRAM core technology and designed for low power consumption and low voltage operation than regular synchronous DRAM (SDRAM).

The MB81ES171625/173225 is dedicated for SiP (System in a Package), and ideally suited for various embedded/consumer applications including digital AVs, and image processing where a large band width and low power consumption memory is needed.

\* : FCRAM is a trademark of Fujitsu Microelectronics Limited, Japan.

### ■ PRODUCT LINEUP

Parameter		MB81ES171625/173225-15-X
Clock Frequency (Max)		66.7 MHz
Burst Mode Cycle Time (Min)	CL = 1	30 ns
	CL = 2	15 ns
Access Time From Clock (Max)	CL = 1	27 ns
	CL = 2	12 ns
XTRAS Cycle Time (Min)		75 ns
Operating Current (Max) (I <sub>DD1</sub> )		30 mA
Power Down Mode Current (Max) (I <sub>DD2P</sub> )		1 mA
Self-refresh Current (Max) (I <sub>DD6</sub> )		5 mA

# MB81ES171625/173225-15-X

## ■ FEATURES

- FCRAM core with Single Data Rate SDRAM interface
- 512 K word × 16 bit × 2 bank or 256 K word × 32 bit × 2 bank organization
- Single +1.8 V Supply ±0.15 V tolerance
- CMOS I/O interface
- Programmable burst type, burst length, and CAS latency
  - Burst type : Sequential Mode, Interleave Mode
  - Burst length : 1, 2, 4, 8, full column (64 : ×16 bit, 32 : ×32 bit)
  - CAS latency
    - MB81ES171625/173225-15-X
      - CL = 1 (Min  $t_{CK}$  = 30 ns, Max 33.3 MHz)
      - CL = 2 (Min  $t_{CK}$  = 15 ns, Max 66.7 MHz)
- 2 K refresh cycles every 4 ms
- Auto- and Self-refresh
- CKE power down mode
- Output Enable and Input Data Mask
- Burst Stop command at full column burst
- Burst read/write
- 66.7 MHz Clock frequency



# MB81ES171625/173225-15-X

• MB81ES173225

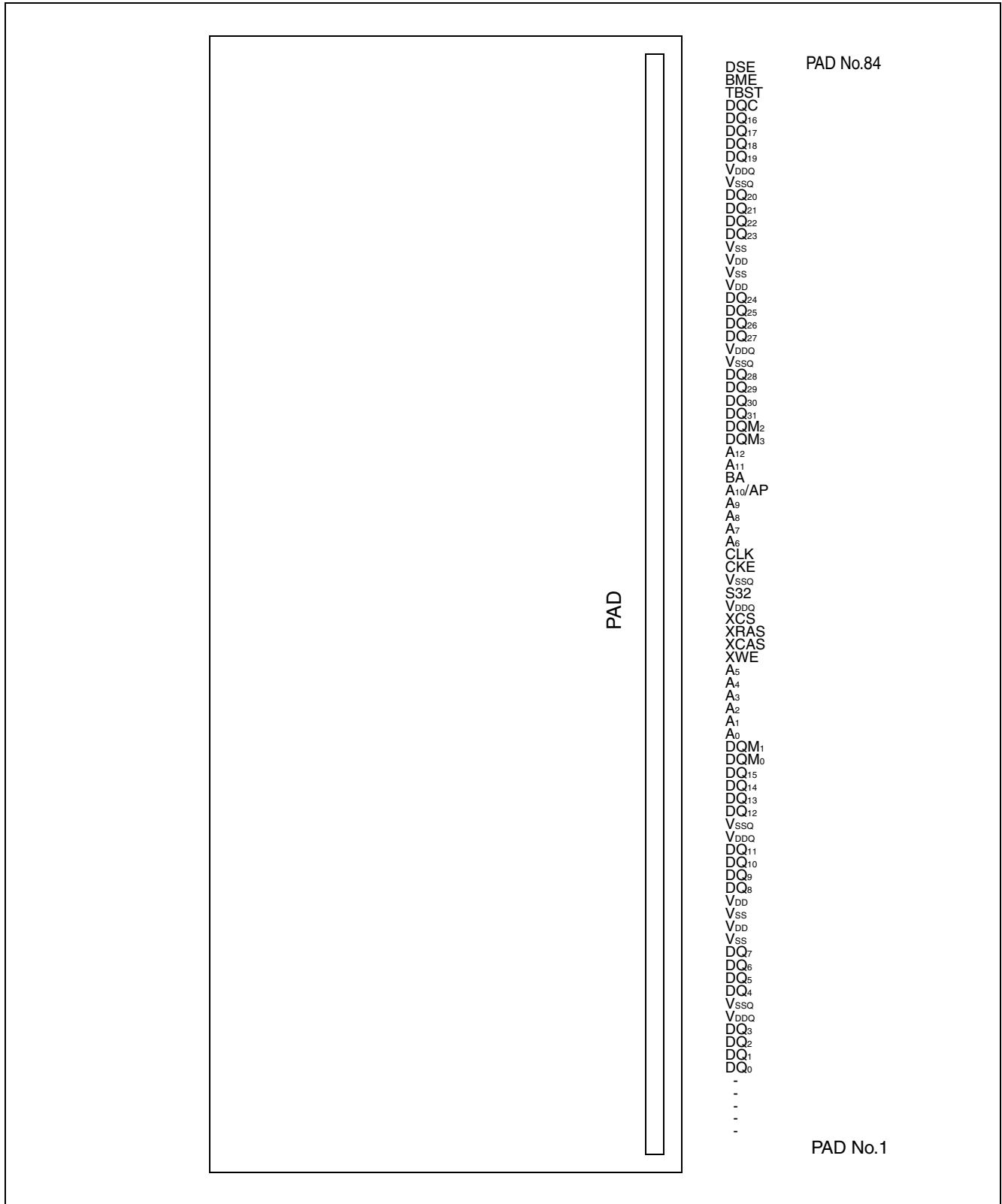

## ■ PAD DESCRIPTIONS

### • MB81ES171625

Symbol	Function
VDD, VDDQ	Supply Voltage
VSS, VSSQ	Ground
DQ <sub>15</sub> to DQ <sub>0</sub>	Data I/O
DQM <sub>1</sub> to DQM <sub>0</sub>	DQ MASK
XWE	Write Enable
XCAS	Column Address Strobe
XRAS	Row Address Strobe
XCS	Chip Select
BA	Bank Select
AP	Auto Precharge Enable
A <sub>12</sub> to A <sub>0</sub>	Address Input      • Row : A <sub>12</sub> to A <sub>0</sub> • Column : A <sub>5</sub> to A <sub>0</sub>
CKE	Clock Enable
CLK	Clock Input
TBST	BIST Control
BME	Burn In Enable
DSE	Disable
DQC	BIST Output
S16	× 16 Select

### • MB81ES173225

Symbol	Function
VDD, VDDQ	Supply Voltage
VSS, VSSQ	Ground
DQ <sub>31</sub> to DQ <sub>0</sub>	Data I/O
DQM <sub>3</sub> to DQM <sub>0</sub>	DQ MASK
XWE	Write Enable
XCAS	Column Address Strobe
XRAS	Row Address Strobe
XCS	Chip Select
BA	Bank Select
AP	Auto Precharge Enable
A <sub>12</sub> to A <sub>0</sub>	Address Input      • Row : A <sub>12</sub> to A <sub>0</sub> • Column : A <sub>4</sub> to A <sub>0</sub>
CKE	Clock Enable
CLK	Clock Input
TBST	BIST Control
BME	Burn In Enable
DSE	Disable
DQC	BIST Output
S32	× 32 Select

# MB81ES171625/173225-15-X

## ■ BLOCK DIAGRAM

### • MB81ES171625

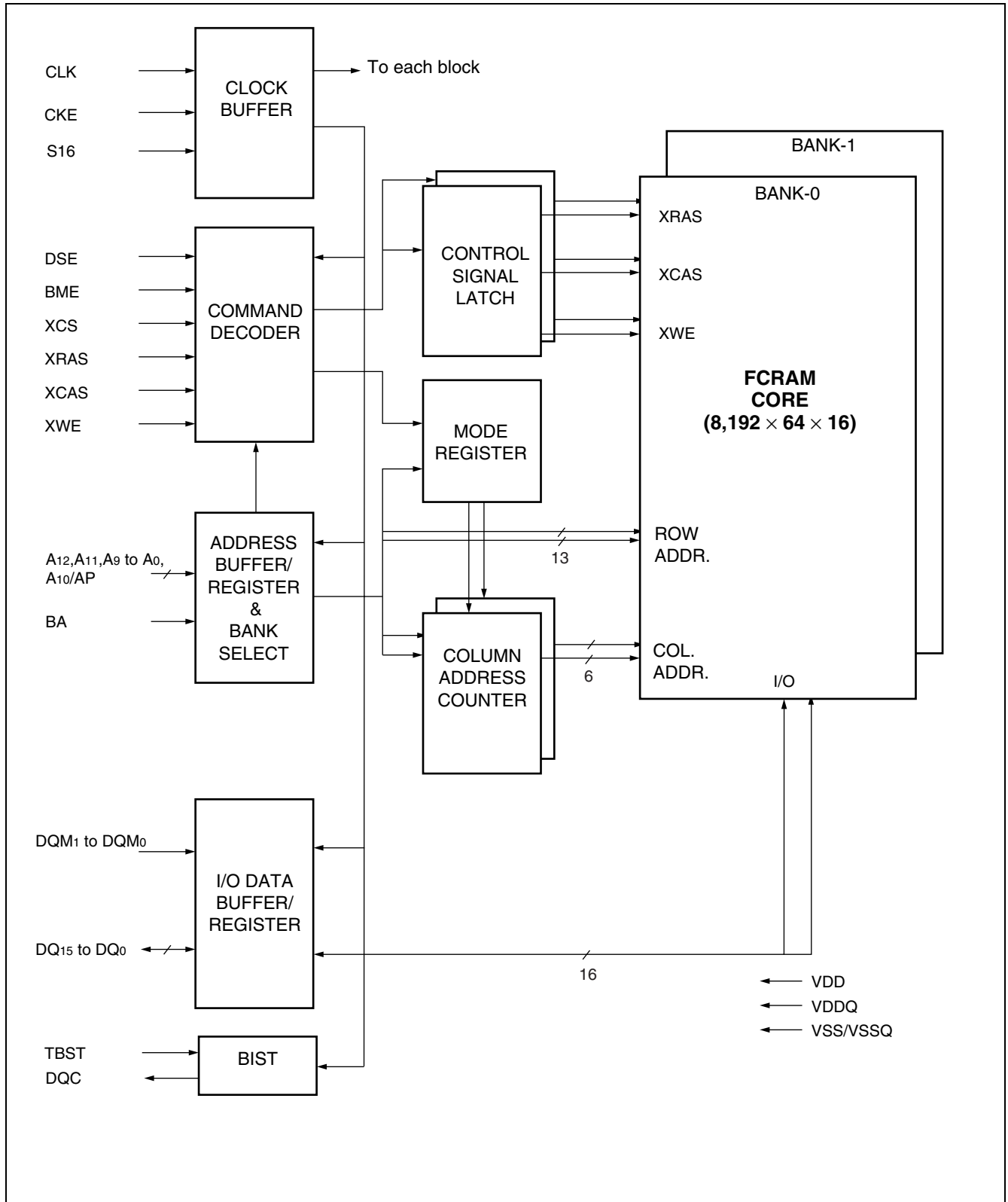

# MB81ES171625/173225-15-X

## • MB81ES173225

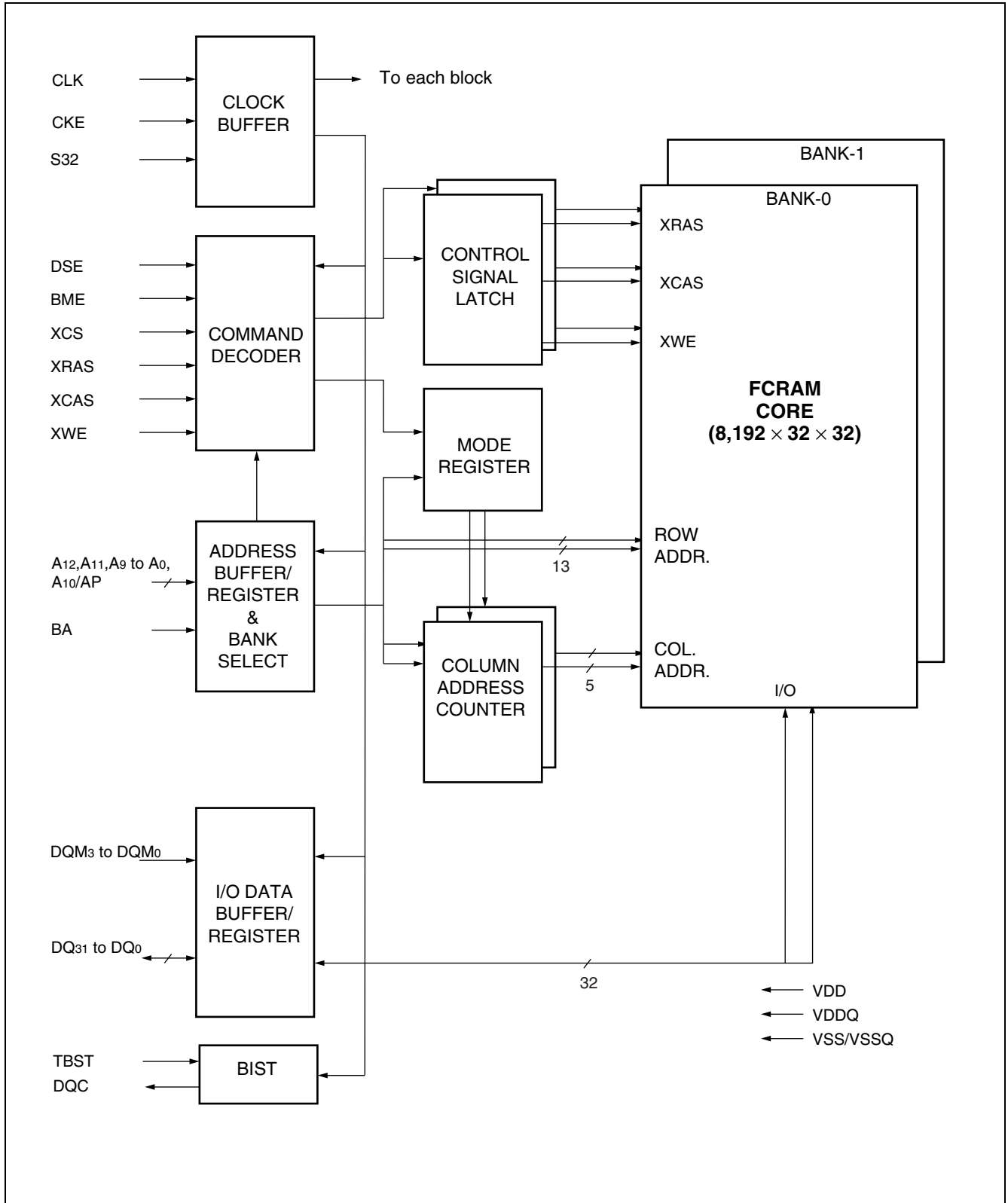

# MB81ES171625/173225-15-X

## FUNCTIONAL TRUTH TABLE

### 1. Command Truth Table

Function	Command	CKE		XCS	XRAS	XCAS	XWE	BA	A <sub>10</sub> /AP	A <sub>12</sub> to A <sub>6</sub>	A <sub>5</sub>	A <sub>4</sub> to A <sub>0</sub>	
		n-1	n										
Device Deselect *1	DESL	H	X	H	X	X	X	X	X	X	X	X	
No Operation *1	NOP	H	X	L	H	H	H	X	X	X	X	X	
Burst Stop*2	BST	H	X	L	H	H	L	X	X	X	X	X	
Read *3	X16	READ	H	X	L	H	L	H	V	L	X	V	V
	X32		H	X	L	H	L	H	V	L	X	X	V
Read with Auto-precharge *3	X16	READA	H	X	L	H	L	H	V	H	X	V	V
	X32		H	X	L	H	L	H	V	H	X	X	V
Write *3	X16	WRIT	H	X	L	H	L	L	V	L	X	V	V
	X32		H	X	L	H	L	L	V	L	X	X	V
Write with Auto-precharge *3	X16	WRITA	H	X	L	H	L	L	V	H	X	V	V
	X32		H	X	L	H	L	L	V	H	X	X	V
Bank Active *4	ACTV	H	X	L	L	H	H	V	V	V	V	V	
Precharge Single Bank *5	PRE	H	X	L	L	H	L	V	L	X	X	X	
Precharge All Banks *5	PALL	H	X	L	L	H	L	X	H	X	X	X	
Mode Register Set *5, *6	MRS	H	X	L	L	L	L	L	L	V	V	V	

V = Valid, L = Logic Low, H = Logic High, X = either L or H,  
n = state at current clock cycle, n-1 = state at 1 clock cycle before n.

\*1: NOP and DESL commands have the same effect on the part. At DESL command (XCS = "H"), all input signals are ignored, but hold the internal state. NOP command (XCS = "L", XRAS = XCAS = XWE = "H") is no effect on device operation and the internal state continues.

\*2: BST command is effective on every Burst Length. (BL = 1, 2, 4, 8, full column)

\*3: READ, READA, WRIT and WRITA commands should be issued only after the corresponding bank has been activated (ACTV command). Refer to "STATE DIAGRAM".

\*4: ACTV command should be issued only after the corresponding bank has been precharged (PRE or PALL command).

\*5: Required after power up. Refer to "17. Power-Up- Initialization" in "FUNCTIONAL DESCRIPTION."

\*6: MRS command should be issued only after all banks have been precharged (PRE or PALL command) and DQ is in High-Z. Refer to "STATE DIAGRAM".

Notes: • All commands assume no CSUS command on previous rising edge of clock.

- All commands are assumed to be valid state transitions.
- All inputs are latched on the rising edge of the clock.
- TBST, BME and DSE should be held Low.
- S16 should be held V<sub>IH</sub>, and S32 should be held V<sub>IL</sub>.

## 2. DQM Truth Table

Function	Command	CKE		DQM
		n-1	n	
Data Input/Output Enable	ENBL	H	X	L
Data Input/Output Disable	MASK	H	X	H

V = Valid, L = Logic Low, H = Logic High, X = either L or H,  
n = state at current clock cycle, n-1 = state at 1 clock cycle before n.

- Notes :
- MB81ES171625; DQM<sub>0</sub> and DQM<sub>1</sub> control DQ<sub>7</sub> to DQ<sub>0</sub> and DQ<sub>15</sub> to DQ<sub>8</sub>, respectively.
  - MB81ES173225; DQM<sub>0</sub>, DQM<sub>1</sub>, DQM<sub>2</sub> and DQM<sub>3</sub> control DQ<sub>7</sub> to DQ<sub>0</sub>, DQ<sub>15</sub> to DQ<sub>8</sub>, DQ<sub>23</sub> to DQ<sub>16</sub>, and DQ<sub>31</sub> to DQ<sub>24</sub>, respectively.
  - All commands assume no CSUS command on previous rising edge of clock.
  - All commands are assumed to be valid state transition.
  - All inputs are latched on the rising edge of clock.
  - TBST, BME and DSE should be held Low.
  - S16 should be held V<sub>IH</sub>, and S32 should be held V<sub>IL</sub>.

## 3. CKE Truth Table

Current State	Function	Com- mand	CKE		XCS	XRAS	XCAS	XWE	BA	A <sub>10</sub> / AP	A <sub>12</sub> , A <sub>11</sub> , A <sub>9</sub> to A <sub>0</sub>
			n-1	n							
Bank Active	Clock Suspend Mode Entry *1	CSUS	H	L	X	X	X	X	X	X	X
Any (Except Idle)	Clock Suspend Continue *1	—	L	L	X	X	X	X	X	X	X
Clock Suspend	Clock Suspend Mode Exit	—	L	H	X	X	X	X	X	X	X
Idle	Auto-refresh Command *2	REF	H	H	L	L	L	H	X	X	X
Idle	Self-refresh Entry *2, *3	SELF	H	L	L	L	L	H	X	X	X
Self Refresh	Self-refresh Exit *4	SELFX	L	H	L	H	H	H	X	X	X
			L	H	H	X	X	X	X	X	X
Idle	Power Down Entry *3	PD	H	L	L	H	H	H	X	X	X
			H	L	H	X	X	X	X	X	X
Power Down	Power Down Exit	—	L	H	L	H	H	H	X	X	X
			L	H	H	X	X	X	X	X	X

V = Valid, L = Logic Low, H = Logic High, X = either L or H,  
n = state at current clock cycle, n-1 = state at 1 clock cycle before n.

- \*1 : CSUS command requires that at least one bank is active. Refer to “**STATE DIAGRAM**”.
- \*2 : REF and SELF commands should be issued only after all banks have been precharged (PRE or PALL command). Refer to “**STATE DIAGRAM**”.
- \*3 : SELF and PD commands should be issued only after the last read data have been appeared on DQ.
- \*4 : CKE should be held High during t<sub>REFC</sub>.

- Notes :
- TBST, BME and DSE should be held Low.
  - S16 should be held V<sub>IH</sub>, and S32 should be held V<sub>IL</sub>.
  - All commands assume no CSUS command on previous rising edge of clock.
  - All commands assumed to be valid state transition.
  - All inputs are latched on the rising edge of clock.

# MB81ES171625/173225-15-X

## 4. Operation Command Table (Applicable to single bank)

Current State	XCS	XRAS	XCAS	XWE	Addr	Command	Function
Idle	H	X	X	X	X	DESL	NOP
	L	H	H	H	X	NOP	
	L	H	H	L	X	BST	NOP *1
	L	H	L	H	BA, CA, AP	READ/READA	Illegal *2
	L	H	L	L	BA, CA, AP	WRIT/WRITA	
	L	L	H	H	BA, RA	ACTV	Bank Active after t <sub>RCD</sub>
	L	L	H	L	BA, AP	PRE	NOP
	L	L	H	L	AP	PALL	NOP *1
	L	L	L	H	X	REF/SELF	Auto-refresh or Self-refresh *3, *5
	L	L	L	L	MODE	MRS	Mode Register Set (Idle after t <sub>RSC</sub> ) *3, *6
Bank Active	H	X	X	X	X	DESL	NOP
	L	H	H	H	X	NOP	
	L	H	H	L	X	BST	
	L	H	L	H	BA, CA, AP	READ/READA	Begin Read; Determine AP
	L	H	L	L	BA, CA, AP	WRIT/WRITA	Begin Write; Determine AP
	L	L	H	H	BA, RA	ACTV	Illegal *2
	L	L	H	L	BA, AP	PRE	Precharge
	L	L	H	L	AP	PALL	Precharge *1
	L	L	L	H	X	REF/SELF	Illegal
	L	L	L	L	MODE	MRS	
Read	H	X	X	X	X	DESL	Continue Burst to End → Bank Active
	L	H	H	H	X	NOP	
	L	H	H	L	X	BST	Burst Stop → Bank Active
	L	H	L	H	BA, CA, AP	READ/READA	Terminate Burst, New Read; Determine AP
	L	H	L	L	BA, CA, AP	WRIT/WRITA	Terminate Burst, Start Write; Determine AP *4
	L	L	H	H	BA, RA	ACTV	Illegal *2
	L	L	H	L	BA, AP	PRE	Terminate Burst, Precharge → Idle
	L	L	H	L	AP	PALL	Terminate Burst, Precharge → Idle *1
	L	L	L	H	X	REF/SELF	Illegal
	L	L	L	L	MODE	MRS	

(Continued)

# MB81ES171625/173225-15-X

Current State	XCS	XRAS	XCAS	XWE	Addr	Command	Function
Write	H	X	X	X	X	DESL	Continue Burst to End → Bank Active
	L	H	H	H	X	NOP	
	L	H	H	L	X	BST	Burst Stop → Bank Active
	L	H	L	H	BA, CA, AP	READ/READA	Terminate Burst, Start Read; Determine AP *4
	L	H	L	L	BA, CA, AP	WRIT/WRITA	Terminate Burst, New Write; Determine AP
	L	L	H	H	BA, RA	ACTV	Illegal *2
	L	L	H	L	BA, AP	PRE	Terminate Burst, Precharge → Idle
	L	L	H	L	AP	PALL	Terminate Burst, Precharge → Idle *1
	L	L	L	H	X	REF/SELF	Illegal
	L	L	L	L	MODE	MRS	
Read with Auto-precharge	H	X	X	X	X	DESL	Continue Burst to End → Precharge → Idle
	L	H	H	H	X	NOP	
	L	H	H	L	X	BST	Illegal
	L	H	L	H	BA, CA, AP	READ/READA	Illegal *2
	L	H	L	L	BA, CA, AP	WRIT/WRITA	
	L	L	H	H	BA, RA	ACTV	
	L	L	H	L	BA, AP	PRE	
	L	L	H	L	AP	PALL	Illegal
	L	L	L	H	X	REF/SELF	
	L	L	L	L	MODE	MRS	
L	L	L	L	MODE	MRS		
Write with Auto-precharge	H	X	X	X	X	DESL	Continue Burst to End → Precharge → Idle
	L	H	H	H	X	NOP	
	L	H	H	L	X	BST	Illegal
	L	H	L	H	BA, CA, AP	READ/READA	Illegal *2
	L	H	L	L	BA, CA, AP	WRIT/WRITA	
	L	L	H	H	BA, RA	ACTV	
	L	L	H	L	BA, AP	PRE	
	L	L	H	L	AP	PALL	Illegal
	L	L	L	H	X	REF/SELF	
	L	L	L	L	MODE	MRS	
L	L	L	L	MODE	MRS		

(Continued)

# MB81ES171625/173225-15-X

Current State	XCS	XRAS	XCAS	XWE	Addr	Command	Function
Precharging	H	X	X	X	X	DESL	Idle after $t_{RP}$
	L	H	H	H	X	NOP	
	L	H	H	L	X	BST	
	L	H	L	H	BA, CA, AP	READ/READA	Illegal *2
	L	H	L	L	BA, CA, AP	WRIT/WRITA	
	L	L	H	H	BA, RA	ACTV	
	L	L	H	L	BA, AP	PRE	NOP *7
	L	L	H	L	AP	PALL	NOP *1
	L	L	L	H	X	REF/SELF	Illegal
L	L	L	L	MODE	MRS		
Bank Activating	H	X	X	X	X	DESL	Bank Active after $t_{RCD}$
	L	H	H	H	X	NOP	
	L	H	H	L	X	BST	Bank Active after $t_{RCD}^{*1}$
	L	H	L	H	BA, CA, AP	READ/READA	Illegal *2
	L	H	L	L	BA, CA, AP	WRIT/WRITA	
	L	L	H	H	BA, RA	ACTV	
	L	L	H	L	BA, AP	PRE	
	L	L	H	L	AP	PALL	
	L	L	L	H	X	REF/SELF	Illegal
L	L	L	L	MODE	MRS		
Refreshing	H	X	X	X	X	DESL	Idle after $t_{REFC}$
	L	H	H	H	X	NOP	
	L	H	H	L	X	BST	
	L	H	L	X	X	READ/READA/ WRIT/WRITA	Illegal
	L	L	H	X	X	ACTV/ PRE/PALL	
	L	L	L	X	X	REF/SELF/ MRS	

(Continued)

(Continued)

Current State	XCS	XRAS	XCAS	XWE	Addr	Command	Function
Mode Register Setting	H	X	X	X	X	DESL	Idle after $t_{RSC}$
	L	H	H	H	X	NOP	
	L	H	H	L	X	BST	Illegal
	L	H	L	X	X	READ/READA/ WRIT/WRTA	
	L	L	X	X	X	ACTV/PRE/ PALL/REF/SELF/ MRS	

#### ABBREVIATIONS

L = Logic Low, H = Logic High, X = either L or H  
 RA = Row Address      BA = Bank Address  
 CA = Column Address   AP = Auto Precharge

- \*1: Entry may affect other bank.
- \*2: Illegal to the bank in specified state; entry may be legal to the bank specified by BA, depending on the state of that bank.
- \*3: Illegal if any bank is not idle.
- \*4: Must satisfy bus contention, bus turn around, and/or write recovery requirements.  
 Refer to “11. READ Interrupted by WRITE (Example @ CL = 2, BL = 4)” and “12. WRITE to READ Timing (Example @ CL = 1, BL = 4)” in “■TIMING DIAGRAMS.”
- \*5: SELF command should be issued only after the last read data has been appeared on DQ.
- \*6: MRS command should be issued only when all DQ are in High-Z.
- \*7: NOP in precharging or idle state. PRE may affect to the bank specified BA and AP.

Notes: • TBST, BME and DSE should be held Low.

- S16 should be held  $V_{IH}$ , and S32 should be held  $V_{IL}$ .
- All entries in “4. Operation Command Table” assume that CKE was High during the proceeding clock cycle and the current clock cycle.
- Illegal means that the device operation and/or data-integrity are not guaranteed. If used, power up sequence will be asserted after power shut down.
- All commands assume no CSUS command on previous rising edge of clock.
- All commands are assumed to be valid state transitions.
- All inputs are latched on the rising edge of the clock.

# MB81ES171625/173225-15-X

## 5. Command Truth Table for CKE

Current State	CKE		XCS	XRAS	XCAS	XWE	Addr	Function
	(n-1)	(n)						
Self-refresh	H	X	X	X	X	X	X	Invalid
	L	H	H	X	X	X	X	Exit Self-refresh (Self-refresh Recovery → Idle after t <sub>REFC</sub> )
	L	H	L	H	H	H	X	Illegal
	L	H	L	H	L	X	X	
	L	H	L	L	X	X	X	
	L	L	X	X	X	X	X	Maintain Self-refresh
Self-refresh Recovery	L	X	X	X	X	X	X	Invalid
	H	H	H	X	X	X	X	Idle after t <sub>REFC</sub>
	H	H	L	H	H	H	X	
	H	H	L	H	L	X	X	Illegal
	H	H	L	L	X	X	X	
	H	L	X	X	X	X	X	Illegal *1
Power Down	H	X	X	X	X	X	X	Invalid
	L	H	H	X	X	X	X	Exit Power Down Mode → Idle
	L	H	L	H	H	H	X	
	L	L	X	X	X	X	X	Maintain Power Down Mode
	L	H	L	L	X	X	X	Illegal
	L	H	L	H	H	L	X	
All Banks Idle	H	H	H	X	X	X	V	Refer to "4. Operation Command Table".
	H	H	L	H	X	X	V	
	H	H	L	L	H	X	V	
	H	H	L	L	L	H	X	Auto-refresh
	H	H	L	L	L	L	V	Refer to "4. Operation Command Table".
	H	L	H	X	X	X	X	Power Down
	H	L	L	H	H	H	X	
	H	L	L	H	H	L	X	Illegal
	H	L	L	H	L	X	X	
	H	L	L	L	H	X	X	
	H	L	L	L	L	H	X	Self-refresh *2
	H	L	L	L	L	L	X	Illegal
L	X	X	X	X	X	X	Invalid	

(Continued)

(Continued)

Current State	CKE		XCS	XRAS	XCAS	XWE	Addr	Function
	(n-1)	(n)						
Bank Active Bank Activating Read/Write	H	H	X	X	X	X	X	Refer to "4. Operation Command Table".
	H	L	X	X	X	X	X	Begin Clock Suspend next cycle
	L	X	X	X	X	X	X	Invalid
Clock Suspend	H	X	X	X	X	X	X	
	L	H	X	X	X	X	X	Exit Clock Suspend next cycle
	L	L	X	X	X	X	X	Maintain Clock Suspend
Any State Other Than Listed Above	L	X	X	X	X	X	X	Invalid
	H	H	X	X	X	X	X	Refer to "4. Operation Command Table".
	H	L	X	X	X	X	X	Illegal

V = Valid, L = Logic Low, H = Logic High, X = either L or H

\*1: CKE should be held High for  $t_{REFC}$  period.

\*2: SELF command should be issued only after the last data has been appeared on DQ.

Notes: • TBST, BME and DSE should be held Low.

• S16 should be held  $V_{IH}$ , and S32 should be held  $V_{IL}$ .

• All entries in "COMMAND TRUTH TABLE FOR CKE" are specified at CKE (n) state and CKE input from CKE (n-1) to CKE (n) state must satisfy the corresponding setup and hold time for CKE.

## ■ FUNCTIONAL DESCRIPTION

### 1. SDR I/F FCRAM Basic Function

Three major differences between SDR I/F FCRAMs and conventional DRAMs are : synchronized operation, burst mode, and mode register.

The **synchronized operation** is the fundamental difference. SDR I/F FCRAM uses a clock input for synchronization, while DRAM is basically asynchronous memory although it has been using two clocks, XRAS and XCAS. Each operation of DRAM is determined by their timing phase differences while each operation of SDR I/F FCRAM is determined by commands and all operations are referenced to a rising edge of a clock.

The **burst mode** is a very high speed access mode utilizing an internal column address generator. Once a column address for the first access is set, following addresses are automatically generated by the internal column address counter.

The **mode register** is to configure SDR I/F FCRAM operation and function into desired system conditions. “■MODE REGISTER TABLE” shows how SDR I/F FCRAM can be configured for system requirements by mode register programming.

The program to the mode register should be executed after all banks are precharged.

### 2. FCRAM™

MB81ES171625/173225 utilizes FCRAM core technology. FCRAM is an acronym for Fast Cycle Random Access Memory and provides very fast random cycle time, low latency and low power consumption than regular DRAMs.

### 3. Clock (CLK) and Clock Enable (CKE)

All input and output signals of SDR I/F FCRAM use register type buffers. CLK is used as a trigger for the register and internal burst counter increment. All inputs are latched by a rising edge of CLK. All outputs are validated by a rising edge of CLK. CKE is a high active clock enable signal. When CKE = Low is latched at a clock input during active cycle, the next clock will be internally masked. During idle state (all banks have been precharged) , the Power Down mode (standby) is entered with CKE = Low and this will make extremely low standby current.

### 4. Chip Select (XCS)

XCS enables all command inputs, XRAS, XCAS, XWE and address inputs. When XCS is High, command signals are negated but internal operations such as a burst cycle will not be suspended. If such a control isn't needed, XCS can be tied to ground level.

### 5. Command Input (XRAS, XCAS and XWE)

Unlike a conventional DRAM, XRAS, XCAS and XWE do not directly imply SDR I/F FCRAM operations, such as Row address strobe by XRAS. Instead, each combination of XRAS, XCAS, and XWE input in conjunction with XCS input at the rising edge of the CLK determines SDR I/F FCRAM operations. Refer to “■FUNCTIONAL TRUTH TABLE.”

### 6. Address Input (A<sub>12</sub> to A<sub>0</sub>)

Address input selects an arbitrary location of each memory cell matrix, 524,288 (×16 bit) or 262,144 (×32 bit) . A total of 19 ( × 16 bit) or 18 ( × 32 bit) address input signals are required to decode 13 bit Row addresses and 6 bit (×16 bit) or 5 bit (×32 bit) column addresses matrix. SDR I/F FCRAM adopts an address multiplexer in order to reduce the pin count of the address line. At a Bank Active command (ACTV) , 13 bit Row addresses are initially latched and the remainder of 6 bit ( × 16 bit) or 5 bit ( × 32 bit) Column addresses are then latched by a Column address strobe command of either a Read command (READ or READA) or a Write command (WRIT or WRITA) . A<sub>10</sub> selects READ or READA, WRIT or WRITA and PRE or PALL.

## 7. Bank Select (BA)

This SDR I/F FCRAM has two banks.

Bank selection by BA occurs at Bank Active command (ACTV) followed by read (READ or READA) , write (WRIT or WRITA) , and precharge commands (PRE or PALL) .

## 8. Data Inputs and Outputs (DQ<sub>15</sub> to DQ<sub>0</sub>/DQ<sub>31</sub> to DQ<sub>0</sub>)

Input data is latched and written into the memory at the clock following the write command input. Data output is obtained by the following conditions followed by a read command input :

**t<sub>RAC</sub>** ; from the bank active command when t<sub>RCD</sub> (Min) is satisfied. (This parameter is reference only.)

**t<sub>CAC</sub>** ; from the read command when t<sub>RCD</sub> is greater than t<sub>RCD</sub> (Min) at CL = 1.

**t<sub>AC</sub>** ; from the rising edge of clock after t<sub>RAC</sub> and t<sub>CAC</sub>.

The polarity of the output data is identical to that of input data. Data is valid between access time (determined by the three conditions above) and the next positive clock edge (t<sub>OH</sub>) .

Refer to “■AC CHARACTERISTICS”.

## 9. Data I/O Mask (DQM<sub>1</sub> to DQM<sub>0</sub>/DQM<sub>3</sub> to DQM<sub>0</sub>)

DQM is an active high enable input and has an output disable and input mask function. During burst cycle and when DQM = High is latched by a clock, input is masked at the same clock and output will be masked at CL later while internal burst counter will increment by one or will go to the next stage depending on the burst type.

## 10. Burst Mode Operation

The burst mode provides faster memory access. The burst mode is implemented by keeping the same Row address and by automatically strobing column address. Access time and cycle time of Burst mode is specified as t<sub>CAC</sub>/t<sub>AC</sub> and t<sub>CK</sub>, respectively. The internal column address counter operation is determined by a mode register which defines burst type and the burst count length of 1, 2, 4, 8 bits of boundary or full column. In order to terminate or move from the current burst mode to the next stage while the remaining burst count is more than 1, the following combinations will be required :

### (1) Burst Type

The burst type can be selected either sequential or interleave mode if burst length is 2, 4 or 8. The sequential mode is an incremental decoding scheme within a boundary address to be determined by burst length, it assigns +1 to the previous (or initial) address until reaching the end of boundary address and then wraps around to the least significant address (= 0) . The interleave mode is a scrambled decoding scheme for A<sub>0</sub> through A<sub>2</sub>. If the first access of column address is even (0) , the next address will be odd (1) , or vice-versa.

### (2) Burst Mode Termination and Method of Next Stage Set

Current Stage	Next Stage	Method (Assert the following command)	
Burst Read	Burst Read	Read Command	
Burst Read	Burst Write	1st Step	Mask Command (Normally 3 clock cycles)
		2nd Step	Write Command after t <sub>LOWD</sub>
Burst Write	Burst Write	Write Command	
Burst Write	Burst Read	Read Command	
Burst Read	Precharge	Precharge Command	
Burst Write	Precharge	Precharge Command	

# MB81ES171625/173225-15-X

## (3) Counter Operation of Sequential Mode and Interleave Mode

Burst Length	Starting Column Address			Sequential Mode	Interleave Mode
	A <sub>2</sub>	A <sub>1</sub>	A <sub>0</sub>		
2	X	X	0	0-1	0-1
	X	X	1	1-0	1-0
4	X	0	0	0-1-2-3	0-1-2-3
	X	0	1	1-2-3-0	1-0-3-2
	X	1	0	2-3-0-1	2-3-0-1
	X	1	1	3-0-1-2	3-2-1-0
8	0	0	0	0-1-2-3-4-5-6-7	0-1-2-3-4-5-6-7
	0	0	1	1-2-3-4-5-6-7-0	1-0-3-2-5-4-7-6
	0	1	0	2-3-4-5-6-7-0-1	2-3-0-1-6-7-4-5
	0	1	1	3-4-5-6-7-0-1-2	3-2-1-0-7-6-5-4
	1	0	0	4-5-6-7-0-1-2-3	4-5-6-7-0-1-2-3
	1	0	1	5-6-7-0-1-2-3-4	5-4-7-6-1-0-3-2
	1	1	0	6-7-0-1-2-3-4-5	6-7-4-5-2-3-0-1
	1	1	1	7-0-1-2-3-4-5-6	7-6-5-4-3-2-1-0

## 11. Full Column Burst and Burst Stop Command (BST)

The full column burst is an option of burst length and available only at sequential mode of burst type. This full column burst mode is repeatedly access to the same row. If burst mode reaches the end of column address, then it wraps around to the first column address (= 0) and continues to count until interrupted by the new read (READ) /write (WRIT) , precharge (PRE) , or burst stop (BST) commands. The selection of Auto-precharge option is illegal during the full column burst operation.

BST command is applicable to terminate the burst operation. If BST command is asserted during the burst mode, its operation is terminated immediately and the internal state moves to Bank Active.

When a read mode is interrupted by BST command, the output will be in High-Z.

For the detailed rule, please refer to “8. Read Interrupted by Burst Stop (Example @ BL = Full Column)” in “■TIMING DIAGRAMS.”

When a write mode is interrupted by BST command, the data to be applied at the same time with BST command will be ignored.

## 12. Precharge and Precharge Option (PRE, PALL)

SDR I/F FCRAM memory core is the same as a conventional DRAM's, requiring precharge and refresh operations. Precharge rewrites the bit line and reset the internal Row address line and is executed by the Precharge command (PRE) . With the Precharge command, SDR I/F FCRAM will automatically be in standby state after precharge time (t<sub>RP</sub>) .

The precharged bank is selected by combination of AP and BA when the Precharge command is asserted. If AP = High, all banks are precharged regardless of BA (PALL) . If AP = Low, a bank to be selected by BA is precharged (PRE) .

The auto-precharge enters precharge mode at the end of burst mode of read or write without the Precharge command assertion.

This auto precharge is entered by AP = High when a read or write command is asserted. Refer to “■FUNCTIONAL TRUTH TABLE.”

## 13. Auto-Refresh (REF)

Auto-refresh uses the internal refresh address counter. SDR I/F FCRAM Auto-refresh command (REF) generates the Precharge command internally. All banks of SDR I/F FCRAM should be precharged prior to the Auto-refresh command. The Auto-refresh command should also be asserted every 1.95  $\mu$ s or a total 2048 refresh commands within a 4 ms period.

## 14. Self-Refresh Entry (SELF)

Self-refresh function provides automatic refresh by an internal timer as well as Auto-refresh and will continue the refresh function until cancelled by SELFX.

Self-refresh is entered by applying an Auto-refresh command in conjunction with CKE = Low (SELF) . Once SDR I/F FCRAM enters the self-refresh mode, all inputs except for CKE will be “don't care” (either logic high or low level state) and outputs will be in High-Z state. During a self-refresh mode, CKE = Low should be maintained. SELF command should be issued only after the last read data has been appeared on DQ.

Note : When the burst refresh method is used, a total of 2048 auto-refresh commands must be asserted within 1 ms prior to the self-refresh mode entry.

## 15. Self-Refresh Exit (SELFX)

To exit the Self-refresh mode, apply minimum  $t_{SI}$  after CKE brought high, and then the No operation command (NOP) or the Deselect command (DESL) should be asserted within one  $t_{REFC}$  period. CKE should be held High within one  $t_{REFC}$  period after  $t_{SI}$ . Refer to “16. Self-Refresh Entry and Exit Timing” in “■TIMING DIAGRAMS” for the detail.

It is recommended to assert an Auto-refresh command just after the  $t_{REFC}$  period to avoid the violation of refresh period.

Note : When the burst refresh method is used, a total of 2048 auto-refresh commands must be asserted within 1 ms after the Self-refresh exit.

## 16. Mode Register Set (MRS)

The mode register of SDR I/F FCRAM provides a variety of operations. The register consists of 3 operation fields; Burst Length, Burst Type, and CAS latency. Refer to “■MODE REGISTER TABLE.”

The mode register can be programmed by the Mode Register Set command (MRS) . Each field is set by the address line. Once a mode register is programmed, the contents of the register will be held until re-programmed by another MRS command (or part loses power) . MRS command should be issued only when DQ is in High-Z.

The condition of the mode register is undefined after the power-up stage. It is required to set each field after initialization of SDR I/F FCRAM. Refer to “17. Power-Up Initialization”.

## 17. Power-Up Initialization

SDR I/F FCRAM internal condition after power-up will be undefined. It is required to follow the following Power On Sequence to execute read or write operation.

1. Apply the power and start the clock. Attempt to maintain either NOP or DESL command at the input.
2. Maintain stable power, stable clock, and NOP condition for a minimum of 500  $\mu$ s.
3. Precharge all banks by Precharge (PRE) or Precharge All command (PALL) .
4. Assert minimum of 2 Auto-refresh commands (REF) .
5. Program the mode register by Mode Register Set command (MRS) .

In addition, it is recommended that DQM and CKE track  $V_{DD}$  to insure that output is in High-Z state. The Mode Register Set command (MRS) can be set before 2 Auto-refresh commands (REF) . It is possible to excute 5 before 4.

# MB81ES171625/173225-15-X

## STATE DIAGRAM (Simplified for Single BANK Operation State Diagram)

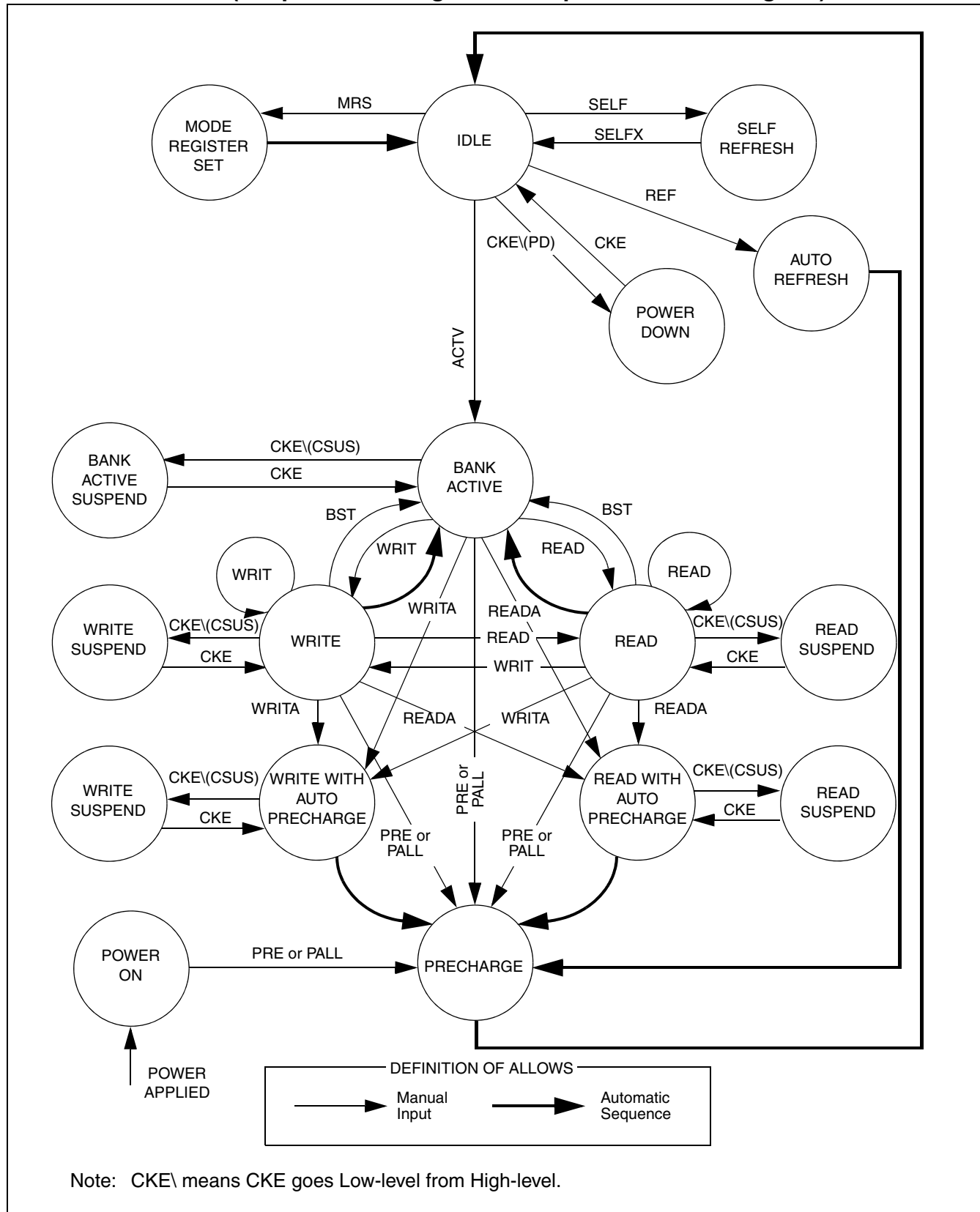

## ■ BANK OPERATION COMMAND TABLE

• Minimum Clock Latency or Delay Time for Single Bank Operation

Second command (same bank) First command	MRS	ACTV	READ	READA	WRIT	WRITA	PRE	PALL	REF	SELF	BST
MRS	$t_{RSC}$	$t_{RSC}$					$t_{RSC}$	$t_{RSC}$	$t_{RSC}$	$t_{RSC}$	$t_{RSC}$
ACTV			$t_{RCD}$	$t_{RCD}$	$t_{RCD}$	$t_{RCD}$	$t_{RAS}$	$t_{RAS}$			1
READ			1	1	*4	*4	*3	*3			1
READA	*1, *2 BL + $t_{RP}$	*1 BL + $t_{RP}$					*3 BL + $t_{RP}$	*3 BL + $t_{RP}$	*1 BL + $t_{RP}$	*1 BL + $t_{RP}$	*1 BL + $t_{RP}$
WRIT			$t_{WR}$	$t_{WR}$	1	1	*3 $t_{DPL}$	*3 $t_{DPL}$			1
WRITA	*1, *2 BL-1 + $t_{DAL}$	*1 BL-1 + $t_{DAL}$					*3 BL-1 + $t_{DAL}$	*3 BL-1 + $t_{DAL}$	*1 BL-1 + $t_{DAL}$	*1 BL-1 + $t_{DAL}$	*1 BL-1 + $t_{DAL}$
PRE	*1, *2 $t_{RP}$	$t_{RP}$					1	1	*1 $t_{RP}$	*1, *5 $t_{RP}$	1
PALL	*2 $t_{RP}$	$t_{RP}$					1	1	$t_{RP}$	*5 $t_{RP}$	1
REF	$t_{REFC}$	$t_{REFC}$					$t_{REFC}$	$t_{REFC}$	$t_{REFC}$	$t_{REFC}$	$t_{REFC}$
SELF	$t_{REFC}$	$t_{REFC}$					$t_{REFC}$	$t_{REFC}$	$t_{REFC}$	$t_{REFC}$	$t_{REFC}$

\*1: Assume all banks are in idle state.

\*2: Assume output is in High-Z state.

\*3: Assume  $t_{RAS}$  (Min) is satisfied.

\*4: Assume no I/O conflict.

\*5: Assume the last data has been appeared on DQ.

Illegal Command.

# MB81ES171625/173225-15-X

## • Minimum Clock Latency or Delay Time for Multi Bank Operation

Second command (other bank) First command	MRS	ACTV	*4 READ	*4 READA	*4 WRIT	*4 WRITA	PRE	PALL	REF	SELF	BST
MRS	t <sub>RSC</sub>	t <sub>RSC</sub>					t <sub>RSC</sub>	t <sub>RSC</sub>	t <sub>RSC</sub>	t <sub>RSC</sub>	t <sub>RSC</sub>
ACTV		*1 t <sub>RRD</sub>	*6 1	*6 1	*6 1	*6 1	*5, *6 1	*6 t <sub>RAS</sub>			1
READ		*1, *3 1	1	1	*8 1	*8 1	*5 1	*5 1			1
READA	*1, *2 BL + t <sub>RP</sub>	*1, *3 1	*5 1	*5 1	*5, *8 1	*5, *8 1	*5 1	*5 BL + t <sub>RP</sub>	*1 BL + t <sub>RP</sub>	*1 BL + t <sub>RP</sub>	*1 BL + t <sub>RP</sub>
WRIT		*1, *3 1	1	1	1	1	*5 1	*5 t <sub>DPL</sub>			1
WRITA	*1, *2 BL-1 + t <sub>DAL</sub>	*1, *3 1	*5 1	*5 1	*5 1	*5 1	*5 1	*5 BL-1 + t <sub>DAL</sub>	*1 BL-1 + t <sub>DAL</sub>	*1 BL-1 + t <sub>DAL</sub>	*1 BL-1 + t <sub>DAL</sub>
PRE	*1, *2 t <sub>RP</sub>	*1, *3 1	*6 1	*6 1	*6 1	*6 1	*5, *6 1	*6 1	*1 t <sub>RP</sub>	*1, *7 t <sub>RP</sub>	1
PALL	*2 t <sub>RP</sub>	t <sub>RP</sub>					1	1	t <sub>RP</sub>	*7 t <sub>RP</sub>	1
REF	t <sub>REFC</sub>	t <sub>REFC</sub>					t <sub>REFC</sub>	t <sub>REFC</sub>	t <sub>REFC</sub>	t <sub>REFC</sub>	t <sub>REFC</sub>
SELFX	t <sub>REFC</sub>	t <sub>REFC</sub>					t <sub>REFC</sub>	t <sub>REFC</sub>	t <sub>REFC</sub>	t <sub>REFC</sub>	t <sub>REFC</sub>

\*1: Assume all banks are in idle state.

\*2: Assume output is in High-Z state.

\*3: t<sub>RRD</sub> (Min) of other bank (the second command will be asserted) is satisfied.

\*4: Assume other bank is in active, read or write state.

\*5: Assume t<sub>RAS</sub> (Min) is satisfied.

\*6: Assume other banks are not in READA/WRITA state.

\*7: Assume the last data has been appeared on DQ.

\*8: Assume no I/O conflict.



Illegal Command.

## ■ MODE REGISTER TABLE

### MODE REGISTER SET

BA	A <sub>12</sub>	A <sub>11</sub>	A <sub>10</sub>	A <sub>9</sub>	A <sub>8</sub> *2	A <sub>7</sub> *2	A <sub>6</sub>	A <sub>5</sub>	A <sub>4</sub>	A <sub>3</sub>	A <sub>2</sub>	A <sub>1</sub>	A <sub>0</sub>	ADDRESS
0 or 1					0	0	CL			BT	BL			MODE REGISTER

A <sub>6</sub>	A <sub>5</sub>	A <sub>4</sub>	CAS Latency
0	0	0	Reserved
0	0	1	1
0	1	0	2
0	1	1	Reserved
1	0	0	Reserved
1	0	1	Reserved
1	1	0	Reserved
1	1	1	Reserved

A <sub>2</sub>	A <sub>1</sub>	A <sub>0</sub>	Burst Length	
			BT = 0	BT = 1 *1
0	0	0	1	Reserved
0	0	1	2	2
0	1	0	4	4
0	1	1	8	8
1	0	0	Reserved	Reserved
1	0	1	Reserved	Reserved
1	1	0	Reserved	Reserved
1	1	1	Full Column	Reserved

A <sub>3</sub>	Burst Type
0	Sequential
1	Interleave

\*1: BL = 1 and Full Column are not applicable to the interleave mode.

\*2: A<sub>7</sub> and A<sub>8</sub> = 1 are reserved for vender test.

# MB81ES171625/173225-15-X

## ■ ABSOLUTE MAXIMUM RATINGS

Parameter	Symbol	Rating		Unit
		Min	Max	
Voltage of V <sub>CC</sub> Supply Relative to V <sub>SS</sub>	V <sub>DD</sub> , V <sub>DDQ</sub>	-0.5	+3.0	V
Voltage at Any Pin Relative to V <sub>SS</sub>	V <sub>IN</sub> , V <sub>OUT</sub>	-0.5	+3.0	V
Short Circuit Output Current	I <sub>OUT</sub>	-13	+13	mA
Storage Temperature	T <sub>STG</sub>	-55	+125	°C

WARNING: Semiconductor devices can be permanently damaged by application of stress (voltage, current, temperature, etc.) in excess of absolute maximum ratings. Do not exceed these ratings.

## ■ RECOMMENDED OPERATING CONDITIONS

(Referenced to V<sub>SS</sub>)

Parameter	Symbol	Value			Unit
		Min	Typ	Max	
Supply Voltage* <sup>1</sup>	V <sub>DD</sub> , V <sub>DDQ</sub>	1.65	1.8	1.95	V
	V <sub>SS</sub> , V <sub>SSQ</sub>	0	0	0	V
Input High Voltage * <sup>2</sup>	V <sub>IH</sub>	V <sub>DDQ</sub> -0.4	—	V <sub>DDQ</sub> + 0.3	V
Input Low Voltage * <sup>3</sup>	V <sub>IL</sub>	-0.3	—	0.4	V
Ambient Temperature	T <sub>A</sub>	-40	—	+85	°C
Junction Temperature* <sup>4</sup>	T <sub>j</sub>	-40	—	+125	°C

\*1 : All voltages are referenced to V<sub>SS</sub>.

\*2 : Overshoot limit: V<sub>IH</sub> (Max) = 3.0 V for pulse width ≤ 5 ns acceptable, pulse width measured at 50% of pulse amplitude.

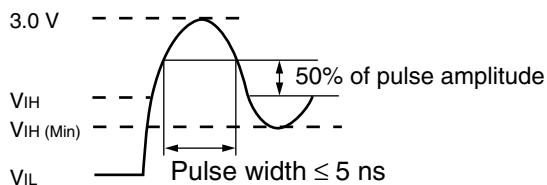

\*3 : Undershoot limit: V<sub>IL</sub> (Min) = V<sub>SS</sub> -1.5 V for pulse width ≤ 5 ns acceptable, pulse width measured at 50% of pulse amplitude.

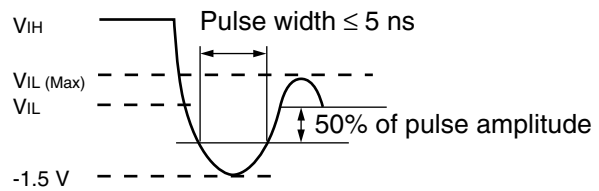

\*4 : The maximum junction temperature of FCRAM (T<sub>j</sub>) should not be more than +125 °C.

T<sub>j</sub> is represented by the power consumption of FCRAM (P<sub>FCRAM</sub>) and Logic LSI (P<sub>D</sub>), the thermal resistance of the package (θ<sub>ja</sub>), and the maximum ambient temperature of the SiP (T<sub>A</sub>Max).

$$T_j\text{Max}[\text{°C}] = T_A\text{Max}[\text{°C}] + \theta_{ja}[\text{°C/W}] \times \Sigma P\text{Max}[\text{W}]$$

$$\Sigma P\text{Max}[\text{W}] = P_{\text{FCRAM}} + P_D$$

WARNING: The recommended operating conditions are required in order to ensure the normal operation of the semiconductor device. All of the device's electrical characteristics are warranted when the device is operated within these ranges.

Always use semiconductor devices within their recommended operating condition ranges. Operation outside these ranges may adversely affect reliability and could result in device failure.

No warranty is made with respect to uses, operating conditions, or combinations not represented on the data sheet. Users considering application outside the listed conditions are advised to contact their representatives beforehand.

## ■ CAPACITANCE

(f = 1 MHz, T<sub>A</sub> = + 25 °C)

Parameter	Symbol	Value			Unit
		Min	Typ	Max	
Input Capacitance, Except for CLK	C <sub>IN1</sub>	2.0	—	5.0	pF
Input Capacitance for CLK	C <sub>IN2</sub>	2.0	—	5.0	pF
I/O Capacitance	C <sub>I/O</sub>	2.0	—	5.0	pF

# MB81ES171625/173225-15-X

## ■ DC CHARACTERISTICS

(At recommended operating conditions unless otherwise noted.)

Parameter	Symbol	Condition	Value		Unit
			Min	Max	
Output High Voltage	$V_{OH(DC)}$	$I_{OH} = -2 \text{ mA}$	$V_{DDQ} - 0.2$	—	V
Output Low Voltage	$V_{OL(DC)}$	$I_{OL} = 2 \text{ mA}$	—	0.2	V
Input Leakage Current (Any Input)	$I_{LI}$	$0 \text{ V} \leq V_{IN} \leq V_{DDQ}$ ; All other pins not under test = 0 V	-5	5	$\mu\text{A}$
Output Leakage Current	$I_{LO}$	$0 \text{ V} \leq V_{IN} \leq V_{DDQ}$ ; Data out disabled	-5	5	$\mu\text{A}$
Operating Current (Average Power Supply Current)	$I_{DD1}$	Burst Length = 1, $t_{RC} = \text{Min}$ for BL = 1, $t_{CK} = \text{Min}$ , One bank active, Output pin open, Addresses changed up to one time during $t_{CK}$ (Min), $0 \text{ V} \leq V_{IN} \leq V_{IL \text{ Max}}$ , $V_{IH \text{ Min}} \leq V_{IN} \leq V_{DDQ}$	—	30	mA
Power Supply Current (Precharge Standby Current)	$I_{DD2P}$	CKE = 0 V, All banks idle, $t_{CK} = \text{Min}$ , Power down mode, $V_{IL} = 0 \text{ V}$ , $V_{IH} = V_{DDQ}$	—	1	mA
	$I_{DD2PS}$	CKE = 0 V, All banks idle, CLK = $V_{DDQ}$ or 0 V, Power down mode, $V_{IL} = 0 \text{ V}$ , $V_{IH} = V_{DDQ}$	—	1	mA
	$I_{DD2N}$	CKE = $V_{DDQ}$ , All banks idle, $t_{CK} = \text{Min}$ , NOP command only, Input signals (except to CMD) are changed one time during 30 ns, $V_{IL} = 0 \text{ V}$ , $V_{IH} = V_{DDQ}$	—	4	mA
	$I_{DD2NS}$	CKE = $V_{DDQ}$ , All banks idle, CLK = $V_{DDQ}$ or 0 V, Input signal are stable, $V_{IL} = 0 \text{ V}$ , $V_{IH} = V_{DDQ}$	—	1	mA

(Continued)

# MB81ES171625/173225-15-X

(Continued)

Parameter	Symbol	Condition	Value		Unit
			Min	Max	
Power Supply Current (Active Standby Current)	I <sub>DD3P</sub>	CKE = 0 V, Any bank active, t <sub>CK</sub> = Min, V <sub>IL</sub> = 0 V, V <sub>IH</sub> = V <sub>DDQ</sub>	—	1	mA
	I <sub>DD3PS</sub>	CKE = 0 V, Any bank active, CLK = V <sub>DDQ</sub> or 0 V, V <sub>IL</sub> = 0 V, V <sub>IH</sub> = V <sub>DDQ</sub>	—	1	mA
	I <sub>DD3N</sub>	CKE = V <sub>DDQ</sub> , Any bank active, t <sub>CK</sub> = Min, NOP command only, Input signals (except to CMD) are changed one time during 30 ns, V <sub>IL</sub> = 0 V, V <sub>IH</sub> = V <sub>DDQ</sub>	—	10	mA
	I <sub>DD3NS</sub>	CKE = V <sub>DDQ</sub> , Any bank active, CLK = V <sub>DDQ</sub> or 0 V, Input signals are stable, V <sub>IL</sub> = 0 V, V <sub>IH</sub> = V <sub>DDQ</sub>	—	1	mA
Average Power Supply Current (Burst mode Current)	I <sub>DD4</sub>	t <sub>CK</sub> = Min, Burst Length = 4, Output pin open, All-banks active, Gapless data, 0 V ≤ V <sub>IN</sub> ≤ V <sub>IL</sub> Max, V <sub>IH</sub> Min ≤ V <sub>IN</sub> ≤ V <sub>DDQ</sub>	—	40	mA
Average Power Supply Current (Refresh Current #1)	I <sub>DD5</sub>	Auto-refresh; t <sub>CK</sub> = Min, t <sub>REFC</sub> = Min, 0 V ≤ V <sub>IN</sub> ≤ V <sub>IL</sub> Max, V <sub>IH</sub> Min ≤ V <sub>IN</sub> ≤ V <sub>DDQ</sub>	—	73	mA
Average Power Supply Current (Refresh Current #2)	I <sub>DD6</sub>	Self-refresh; CLK = V <sub>DDQ</sub> or 0 V, CKE = 0 V, 0 V ≤ V <sub>IN</sub> ≤ V <sub>IL</sub> Max, V <sub>IH</sub> Min ≤ V <sub>IN</sub> ≤ V <sub>DDQ</sub>	—	5	mA

Notes: • All voltages are referenced to V<sub>SS</sub> and V<sub>SSQ</sub>.

- DC characteristics are measured after following “17. Power-Up Initialization” procedure in “FUNCTIONAL DESCRIPTION”.
- I<sub>DD</sub> depends on output termination, load conditions, clock rate, number of address and/or command change within certain period. The specified values are obtained with the output open.

# MB81ES171625/173225-15-X

## ■ AC CHARACTERISTICS

### (1) Basic AC Characteristics

(At recommended operating conditions unless otherwise noted.)

Parameter		Symbol	Value		Unit
			Min	Max	
Clock Period	CL = 1	t <sub>CK1</sub>	30	1000	ns
	CL = 2	t <sub>CK2</sub>	15		ns
Clock High Time *1		t <sub>CH</sub>	6	—	ns
Clock Low Time *1		t <sub>CL</sub>	6	—	ns
Input Setup Time *1		t <sub>SI</sub>	3	—	ns
Input Hold Time except for CKE *1		t <sub>HI</sub>	2	—	ns
XTRAS Access Time *2		t <sub>RAC</sub>	—	57	ns
XCAS Access Time *1, *3		t <sub>CAC</sub>	—	27	ns
Access Time from Clock (t <sub>CK</sub> = Min) *1, *3, *4	CL = 1	t <sub>AC1</sub>	—	27	ns
	CL = 2	t <sub>AC2</sub>	—	12	ns
Output in Low-Z *1		t <sub>LZ</sub>	0	—	ns
Output in High-Z *1, *5	CL = 1	t <sub>HZ1</sub>	2.5	10	ns
	CL = 2	t <sub>HZ2</sub>	2.5	10	ns
Output Hold Time *1, *3		t <sub>OH</sub>	2.5	—	ns
Time between Auto-Refresh command interval *2		t <sub>REFI</sub>	—	1.95	μs
Time between Refresh		t <sub>REF</sub>	—	4	ms
Transition Time		t <sub>T</sub>	0.5	5	ns

\*1: If input signal transition time (t<sub>T</sub>) is longer than 1 ns; [(t<sub>T</sub> / 2) - 0.5] ns should be added to t<sub>CAC</sub> (Max), t<sub>AC</sub> (Max), t<sub>HZ</sub> (Max) and t<sub>SI</sub> (Min) spec values, [(t<sub>T</sub> / 2) - 0.5] ns should be subtracted from t<sub>LZ</sub> (Min), t<sub>HZ</sub> (Min) and t<sub>OH</sub> (Min) spec values, and (t<sub>T</sub> - 1.0) ns should be added to t<sub>CH</sub> (Min), t<sub>CL</sub> (Min), t<sub>SI</sub> (Min), and t<sub>HI</sub> (Min) spec values.

\*2: This value is for reference only.

\*3: Measured under AC test load circuit shown in “(5) Measurement Condition of AC Characteristics (Load Circuit)”.

\*4: t<sub>AC</sub> also specifies the access time at burst mode except for first access at CL = 1.

\*5: Specified where output buffer is no longer driven.

Notes: • AC characteristics are measured after following “17. Power-Up Initialization” procedure in “■FUNCTIONAL DESCRIPTION”.

• AC characteristics assume t<sub>T</sub> = 1 ns, 10 pF of capacitive and 50 Ω of terminated load. Refer to “(5) Measurement Condition of AC Characteristics (Load Circuit)”

• 0.9 V is the reference level for measuring timing of input/output signals.

• Transition times are measured between V<sub>IH</sub> (Min) and V<sub>IL</sub> (Max). Refer to “(6) Setup, Hold and Delay Time”.

## (2) Base Values for Clock Count/Latency

Parameter	Symbol	Value		Unit
		Min	Max	
XRAS Cycle Time *	t <sub>RC</sub>	75	—	ns
XRAS Precharge Time	t <sub>RP</sub>	30	—	ns
XRAS Active Time	t <sub>RAS</sub>	45	110000	ns
XRAS to XCAS Delay Time	t <sub>RCD</sub>	30	—	ns
Write Recovery Time	t <sub>WR</sub>	15	—	ns
XRAS to XRAS Bank Active Delay Time	t <sub>RRD</sub>	15	—	ns
Data-in to Precharge Lead Time	t <sub>DPL</sub>	15	—	ns
Data-in to Active/ Refresh Command Period	t <sub>DAL</sub>	1cyc+ t <sub>RP</sub>	—	ns
Refresh Cycle Time	t <sub>REFC</sub>	75	—	ns
Mode Resister Set Cycle Time	t <sub>RSC</sub>	45	—	ns

\*: t<sub>RC</sub> (Min) is not sum of t<sub>RAS</sub> (Min) and t<sub>RP</sub> (Min) . Actual clock count of t<sub>RC</sub> (l<sub>RC</sub>) must satisfy t<sub>RC</sub> (Min) , t<sub>RAS</sub> (Min) and t<sub>RP</sub> (Min) .

## (3) Clock Count Formula

$$\text{Clock} \geq \frac{\text{Base Value}}{\text{Clock Period}} \quad (\text{Round up to a whole number})$$

Note: All base values are measured from the clock edge at the command input to the clock edge for the next command input. All clock counts are calculated by a simple formula : clock count equals base value divided by clock period (round up to a whole number) .

# MB81ES171625/173225-15-X

## (4) Latency - Fixed Values

(The latency values on these parameters are fixed regardless of clock period.)

Parameter	Symbol	Value	Unit	
CKE to Clock Disable	$t_{CKE}$	1	cycle	
DQM to Output in High-Z	CL = 1	$t_{DQZ1}$	1	cycle
	CL = 2	$t_{DQZ2}$	2	cycle
DQM to Input Data Delay	$t_{DQD}$	0	cycle	
Last Output to Write Command Delay	$t_{OWD}$	2	cycle	
Write Command to Input Data Delay	$t_{DWD}$	0	cycle	
Precharge to Output in High-Z Delay	CL = 1	$t_{ROH1}$	1	cycle
	CL = 2	$t_{ROH2}$	2	cycle
Burst Stop Command to Output in High-Z Delay	CL = 1	$t_{BSH1}$	1	cycle
	CL = 2	$t_{BSH2}$	2	cycle
XCAS to XCAS Delay (Min)	$t_{CCD}$	1	cycle	
XCAS Bank Delay (Min)	$t_{CBD}$	1	cycle	

## (5) Measurement Condition of AC Characteristics (Load Circuit)

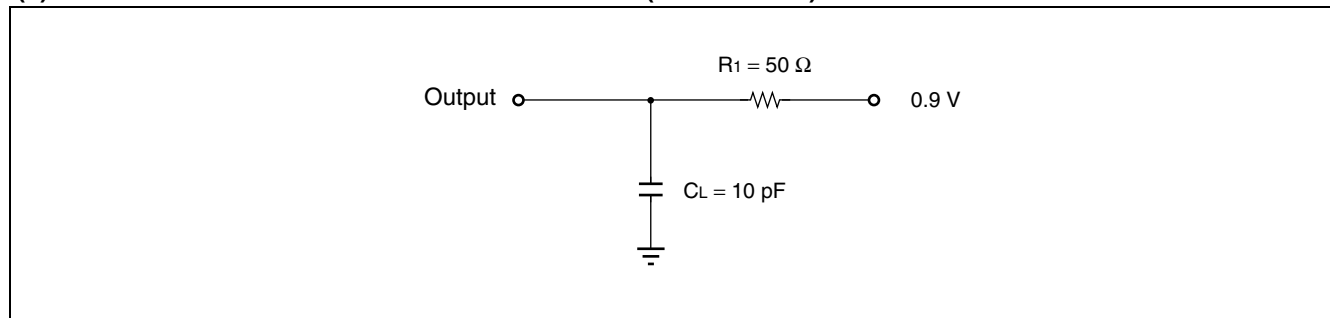

## (6) Setup, Hold and Delay Time

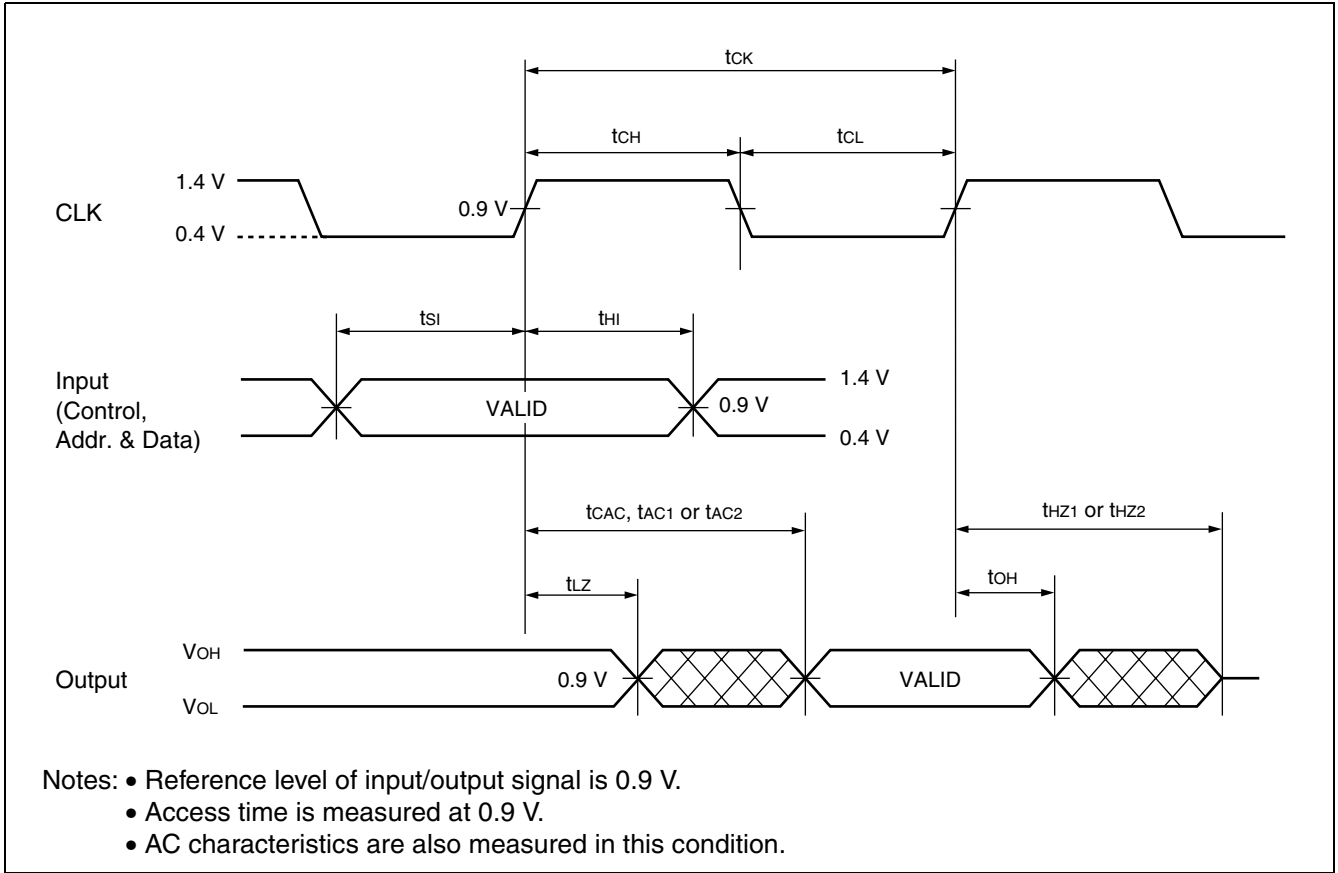

## (7) Delay Time for Power Down Exit

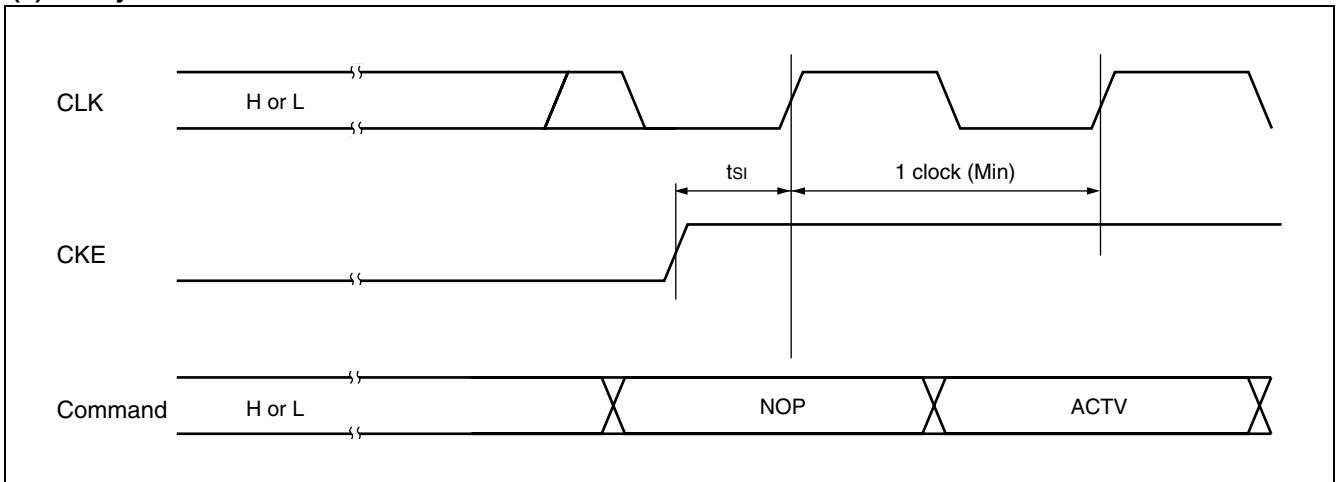

# MB81ES171625/173225-15-X

## (8) Pulse Width

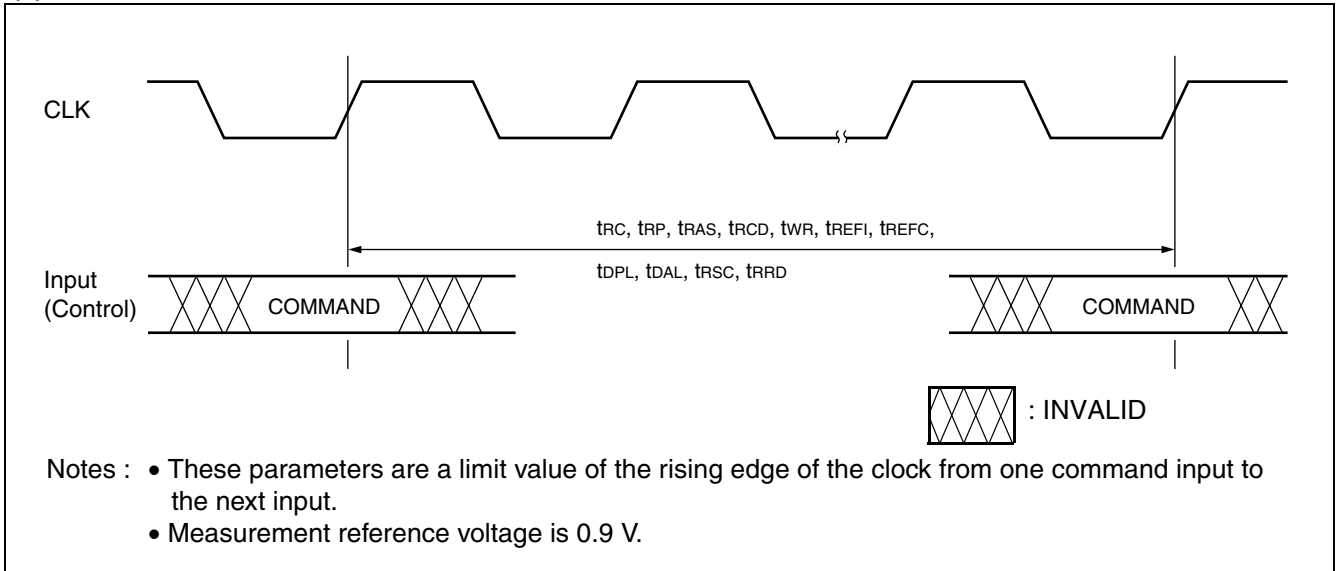

## (9) Access Time

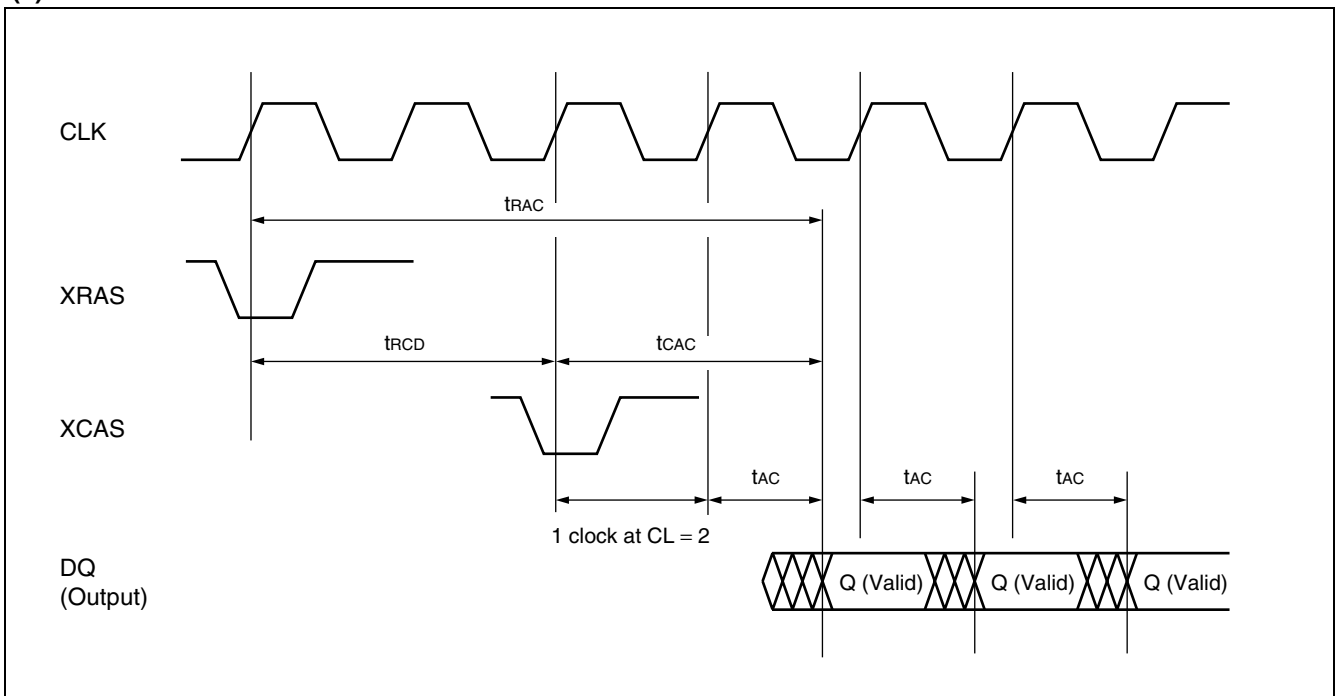

## ■ TIMING DIAGRAMS

### 1. Clock Enable - READ and WRITE Suspend (@ BL = 4)

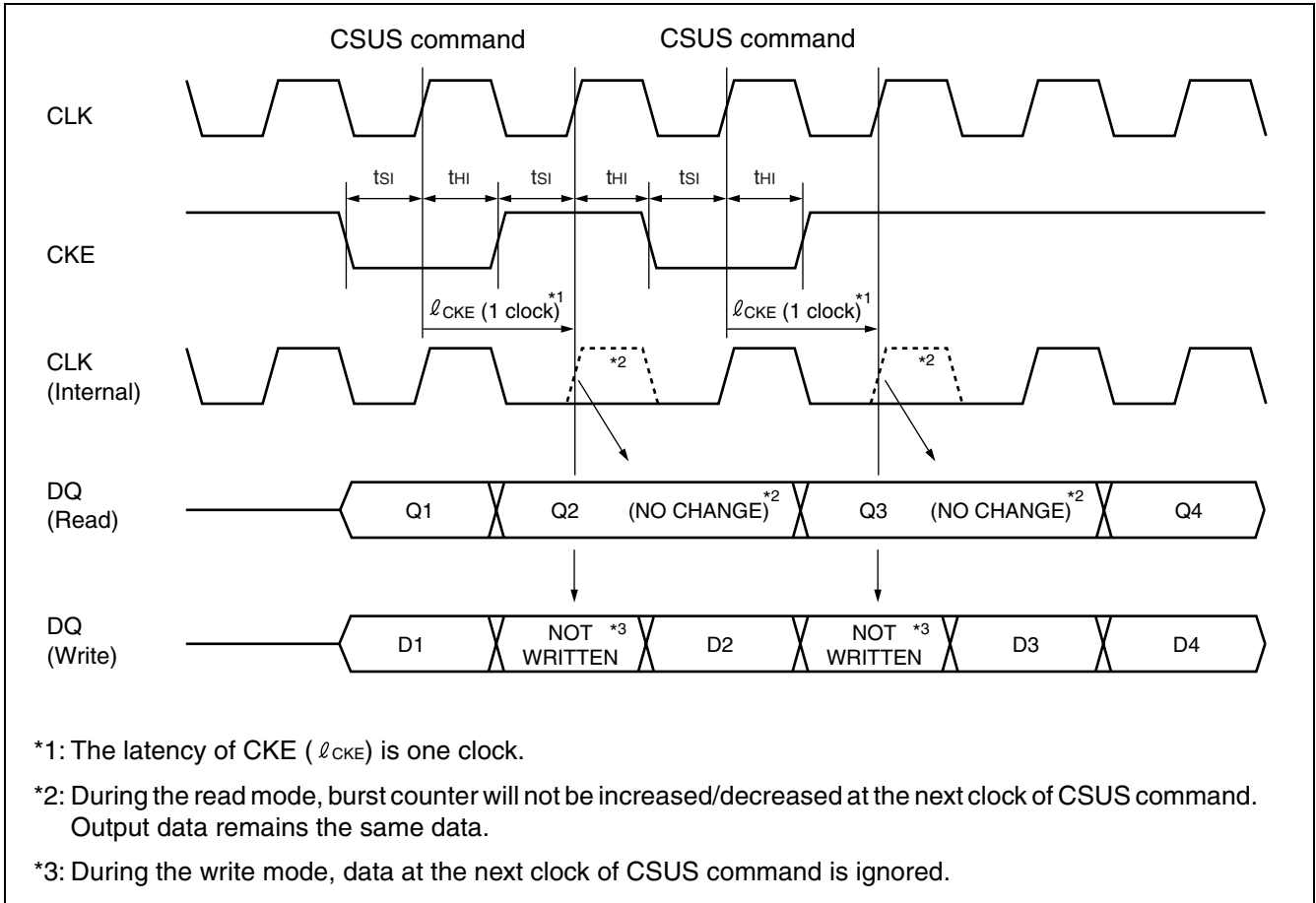

### 2. Clock Enable - Power Down Entry and Exit

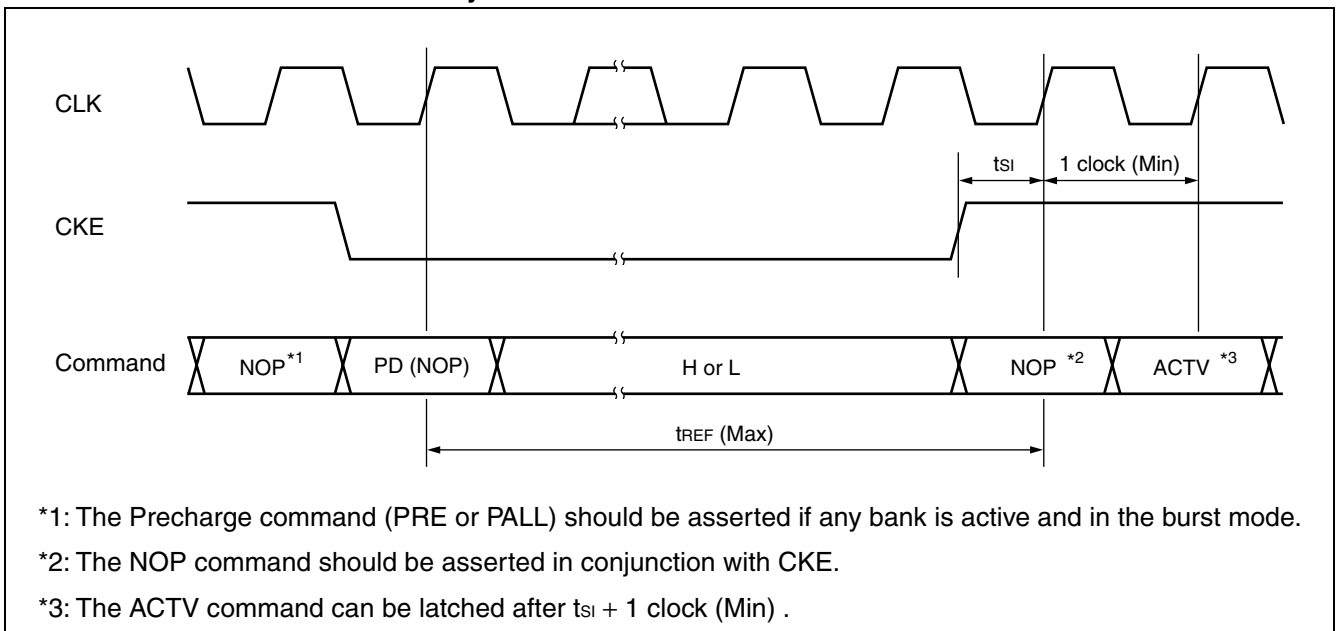

# MB81ES171625/173225-15-X

## 3. Column Address to Column Address Input Delay

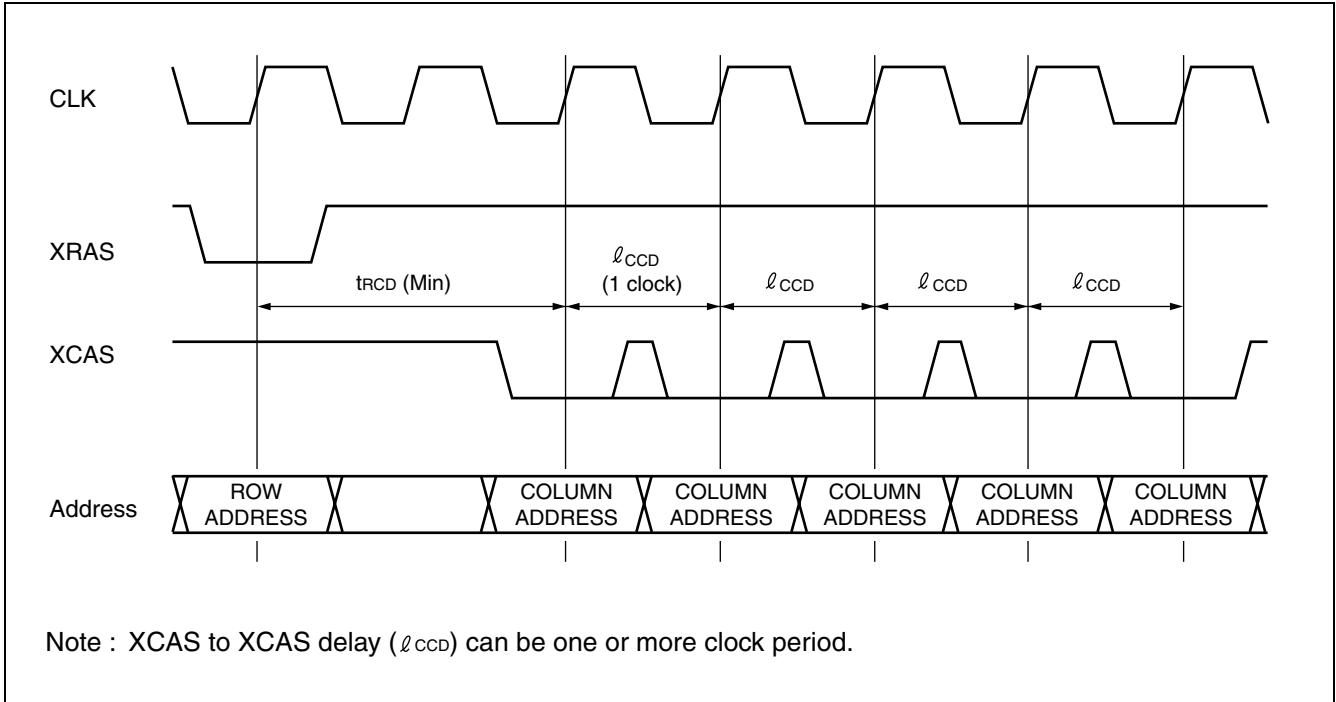

## 4. Different Bank Address Input Delay

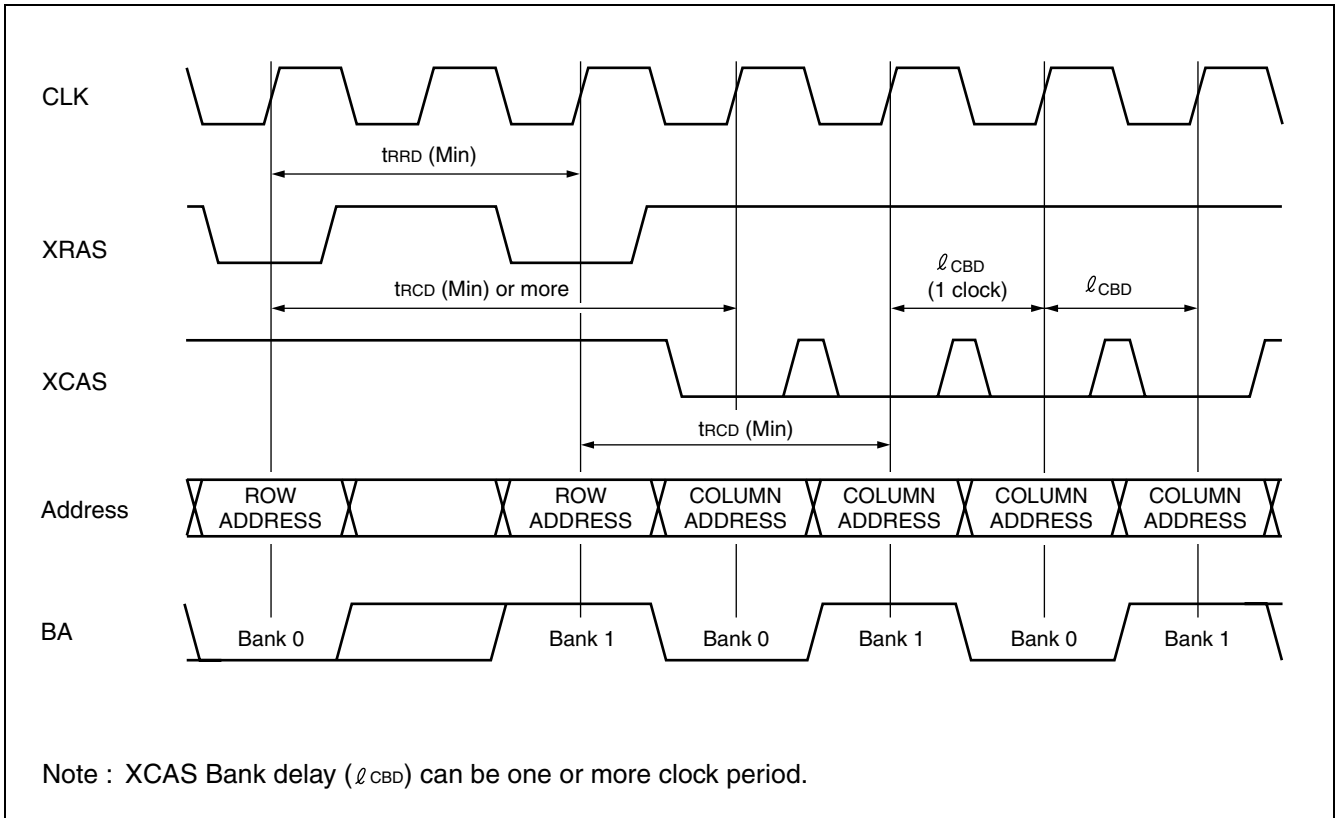

## 5. DQM - Input Mask and Output Disable (@ CL = 2, BL = 4)

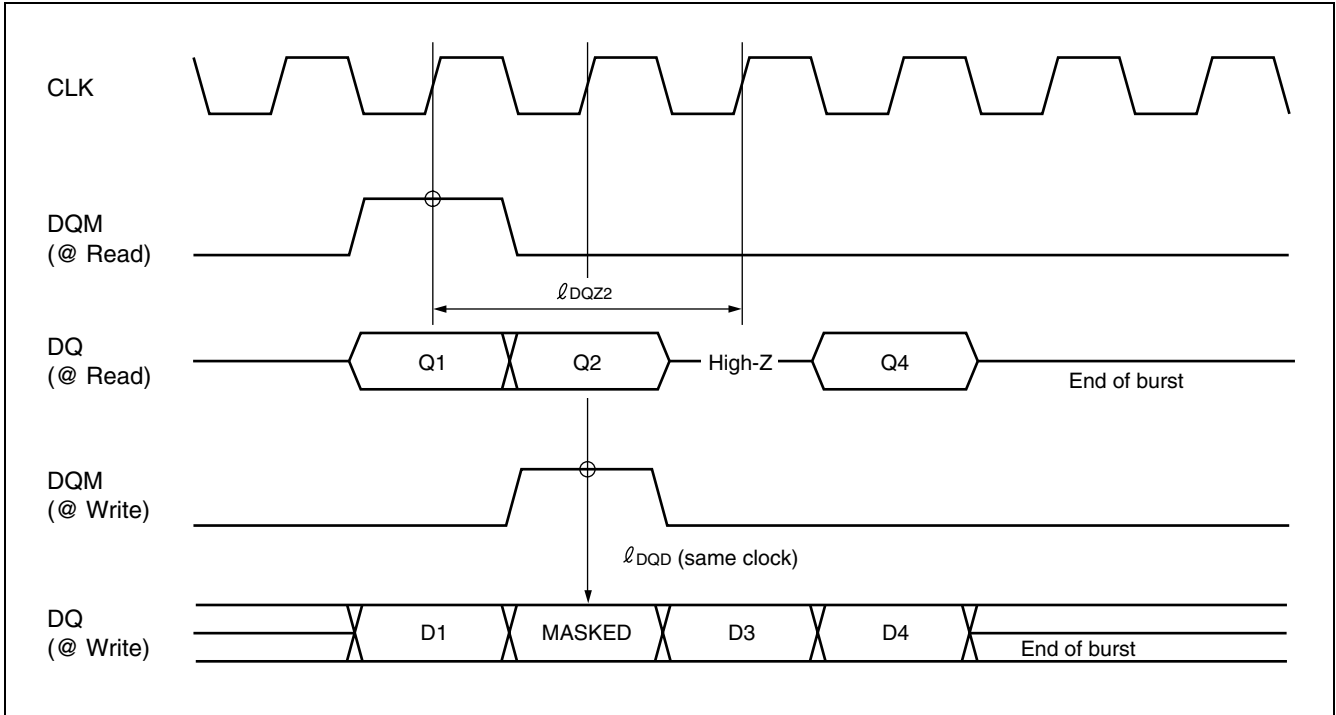

## 6. Precharge Timing (Applied to the Same Bank)

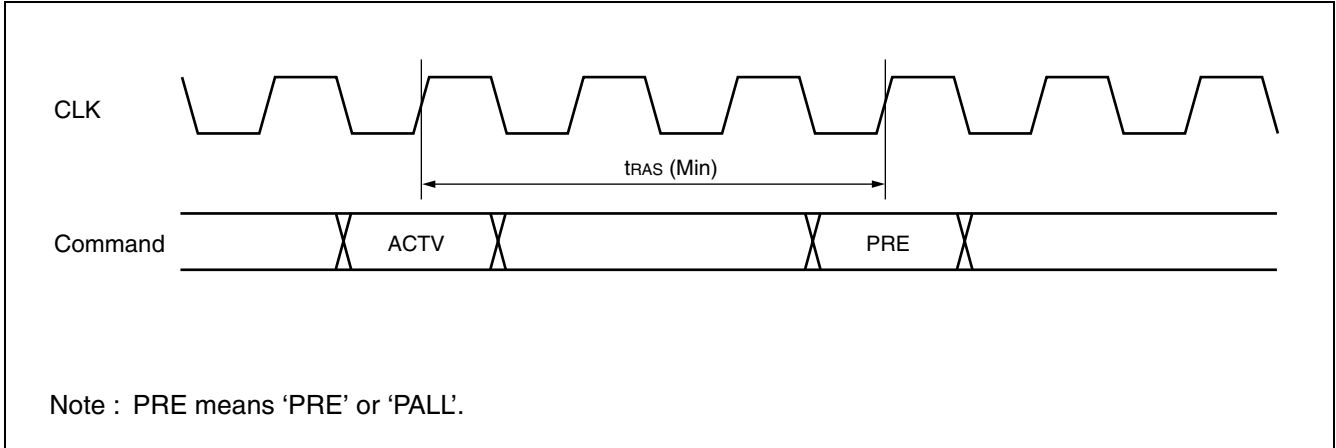

# MB81ES171625/173225-15-X

## 7. READ Interrupted by Precharge (Example @ CL = 2, BL = 4)

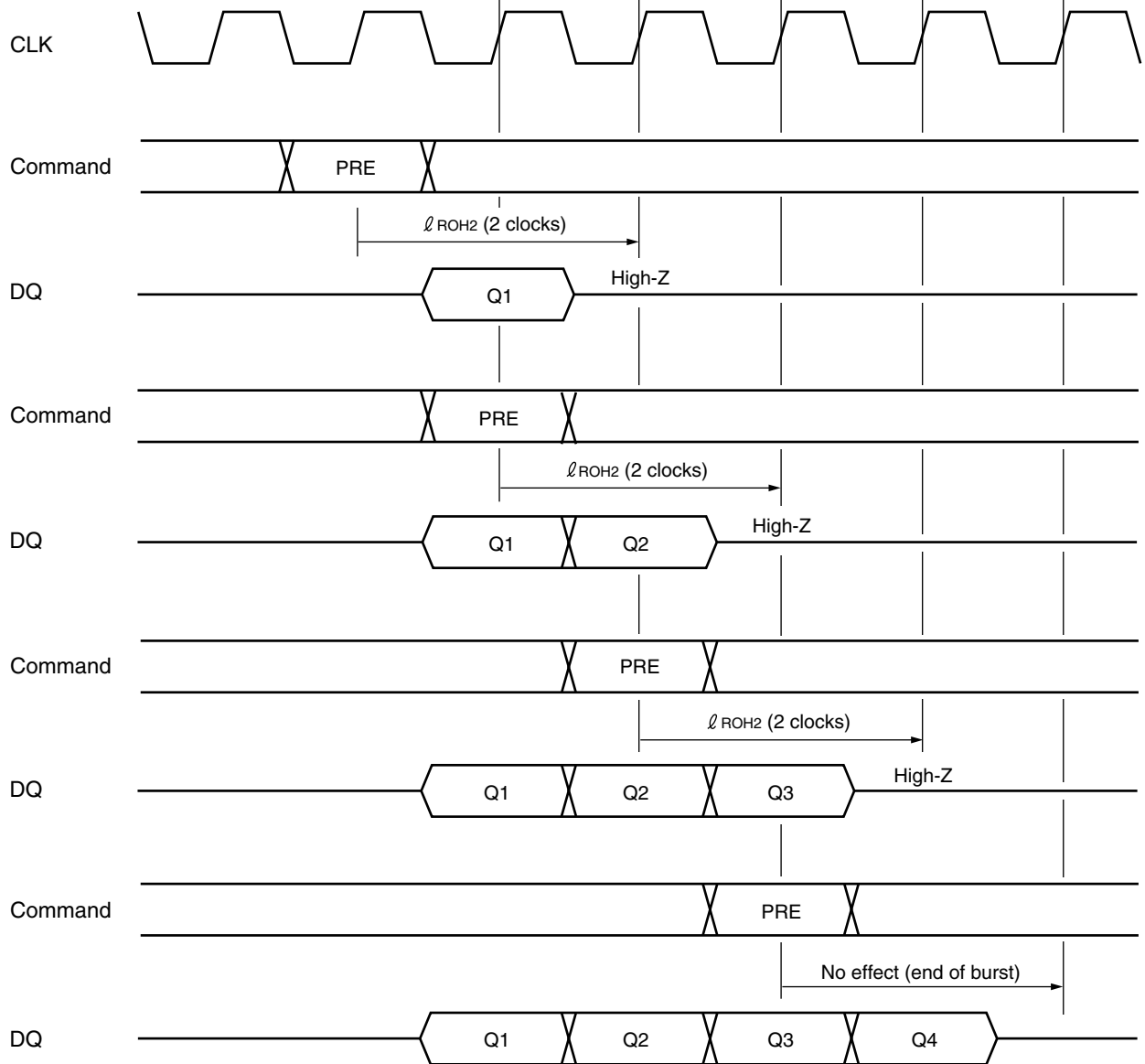

Note : In case of CL = 1, the  $l_{ROH}$  is 1 clock.  
 In case of CL = 2, the  $l_{ROH}$  is 2 clocks.  
 PRE means 'PRE' or 'PALL'.

## 8. READ Interrupted by Burst Stop (Example @ BL = Full Column)

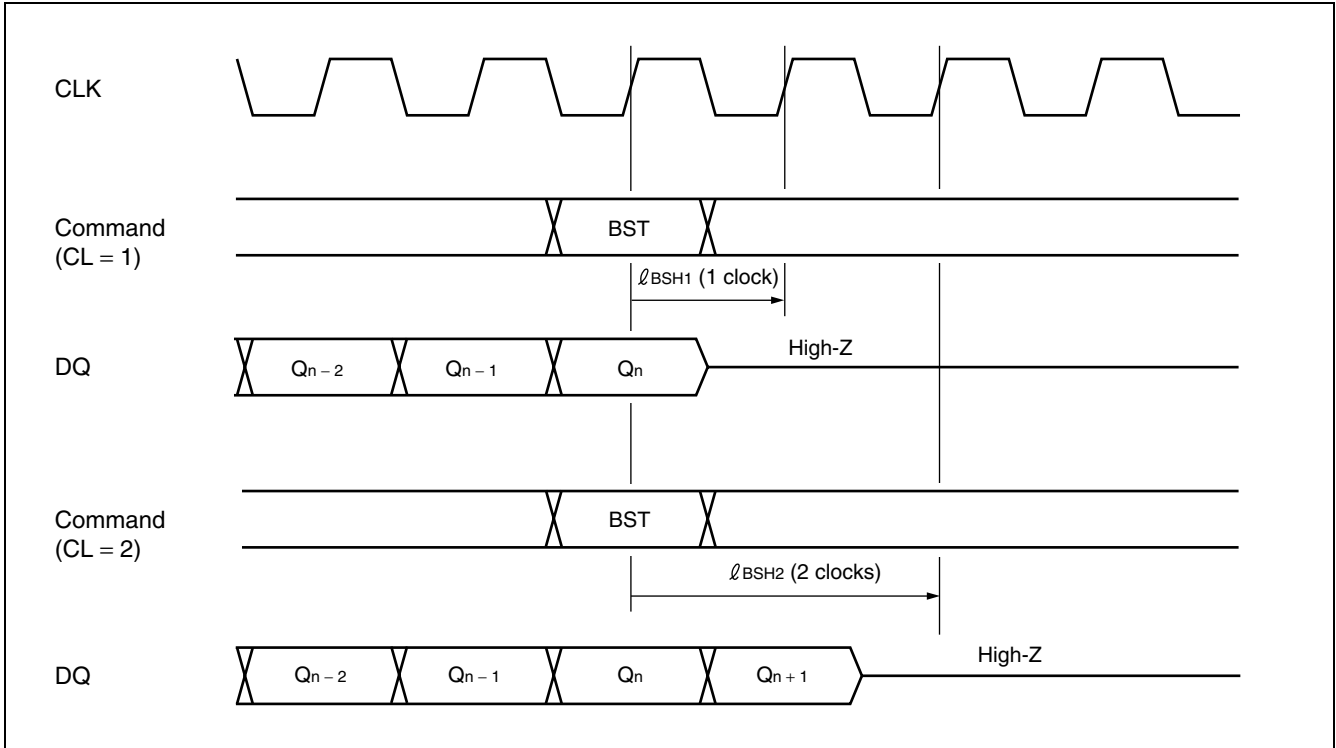

## 9. WRITE Interrupted by Burst Stop (Example @ BL = 2)

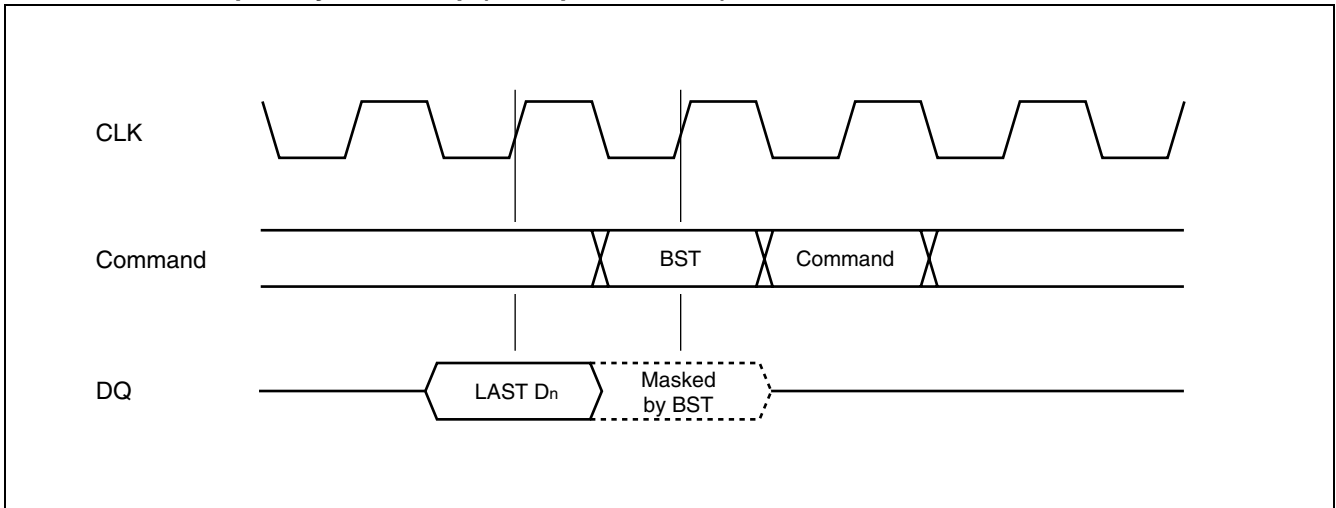

# MB81ES171625/173225-15-X

## 10. WRITE Interrupted by Precharge

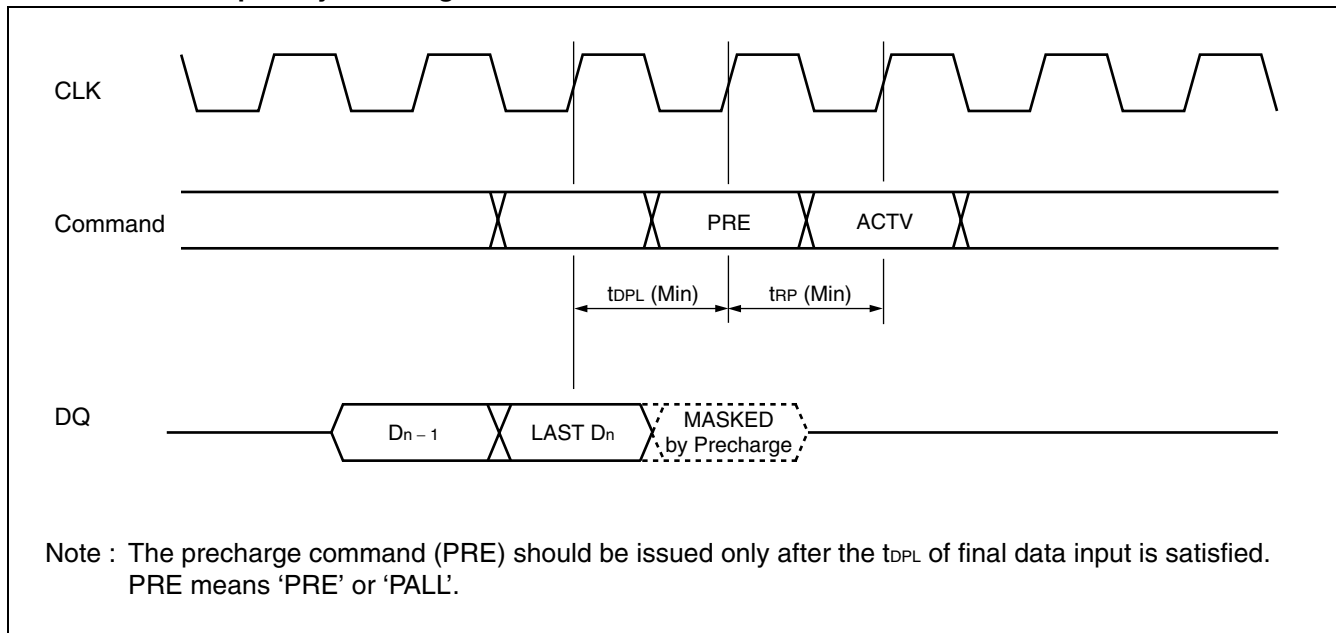

## 11. READ Interrupted by WRITE (Example @ CL = 2, BL = 4)

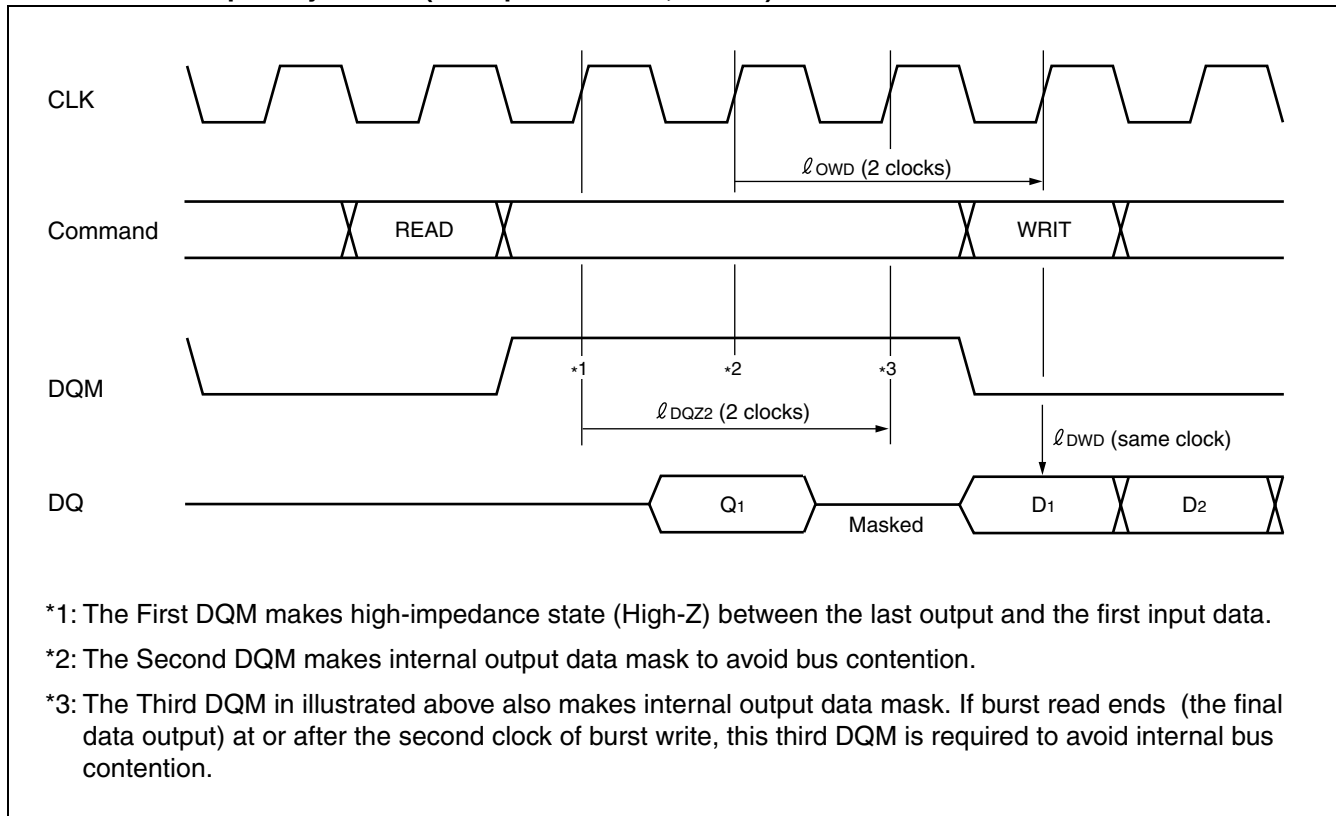

## 12. WRITE to READ Timing (Example @ CL = 1, BL = 4)

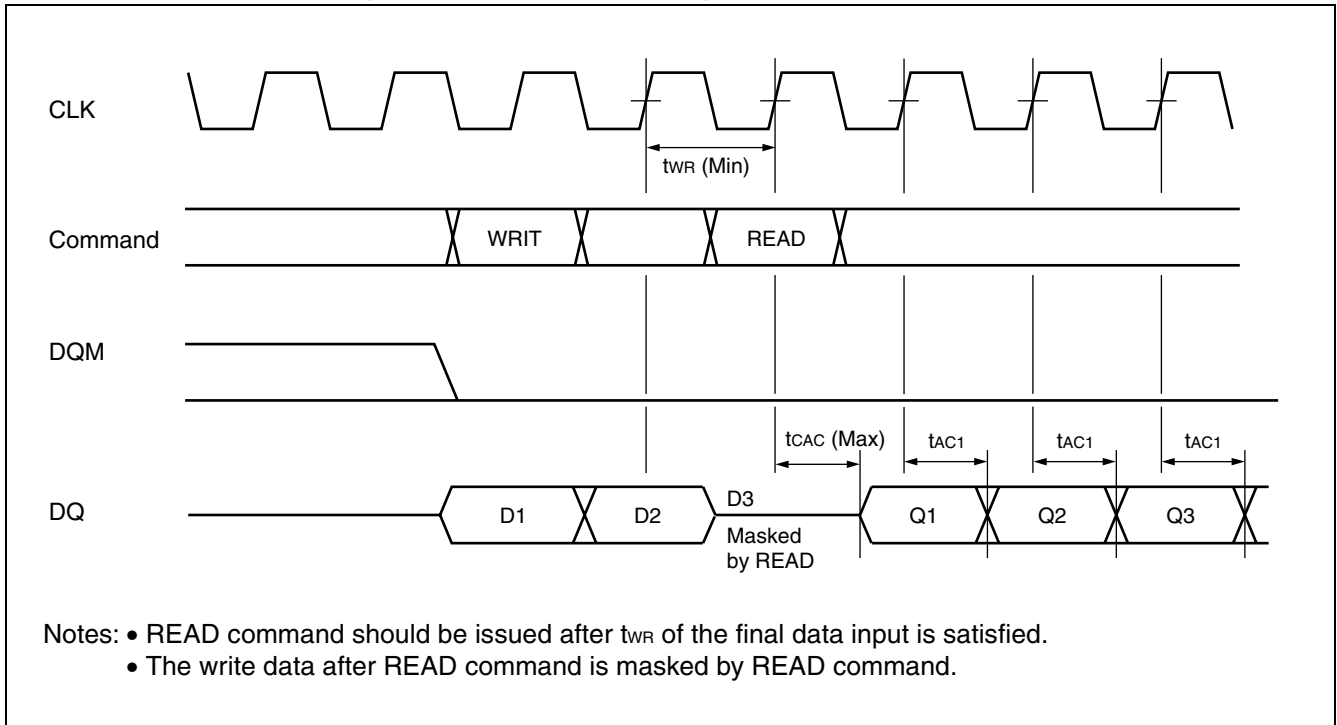

## 13. READ with Auto-Precharge (Example @ CL = 2, BL = 2 Applied to same bank)

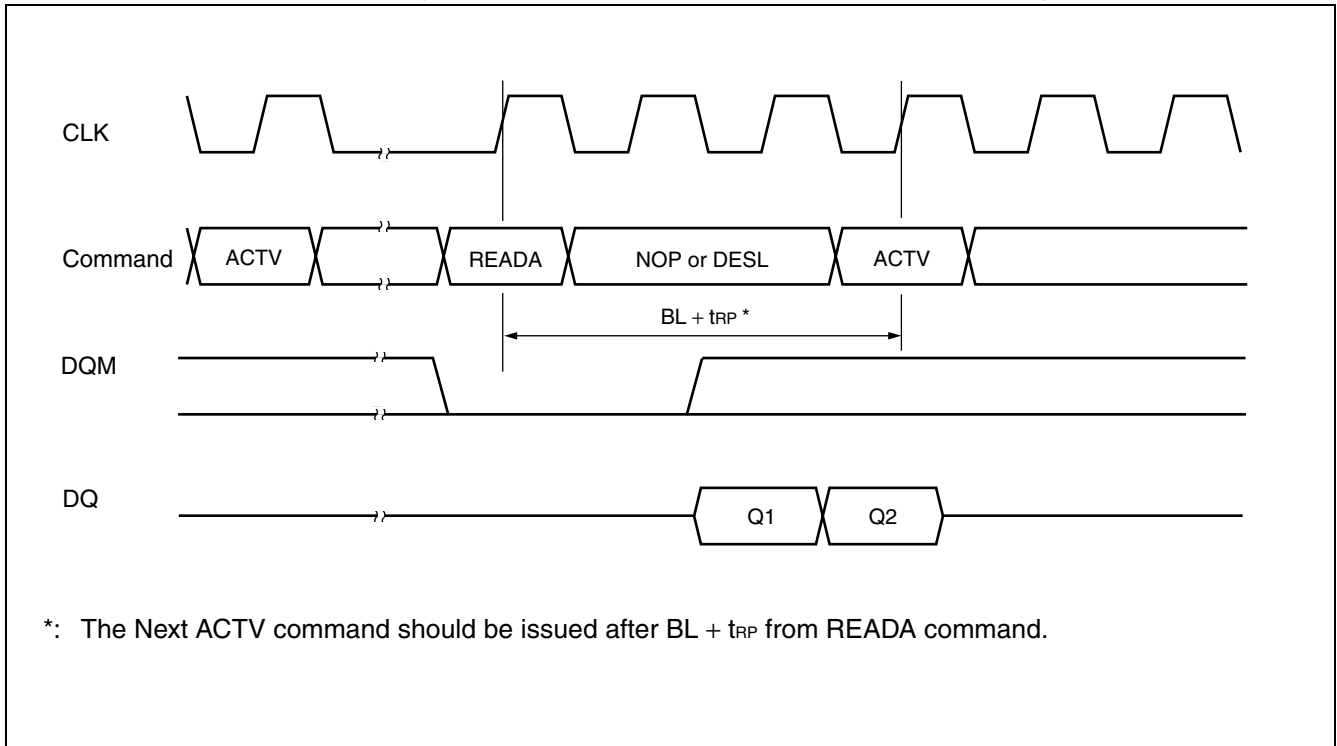

# MB81ES171625/173225-15-X

## 14. WRITE with Auto-Precharge (Example @ CL = 2, BL = 2 Applied to same bank)

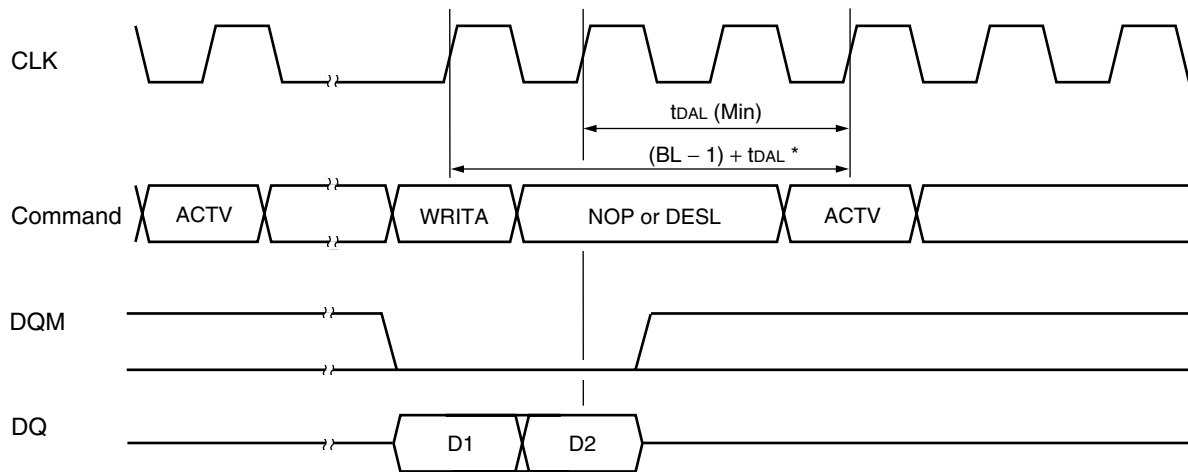

\*: The Next command should be issued after  $(BL - 1) + t_{DAL}$  from WRITA command.

- Notes:
- If the final data is masked by DQM, the precharge does not start at the clock of the final data input.
  - Once the auto precharge command is asserted, no new command within the same bank can be issued.
  - The Auto-precharge command can not be invoked at full column burst operation.

## 15. Auto-Refresh Timing

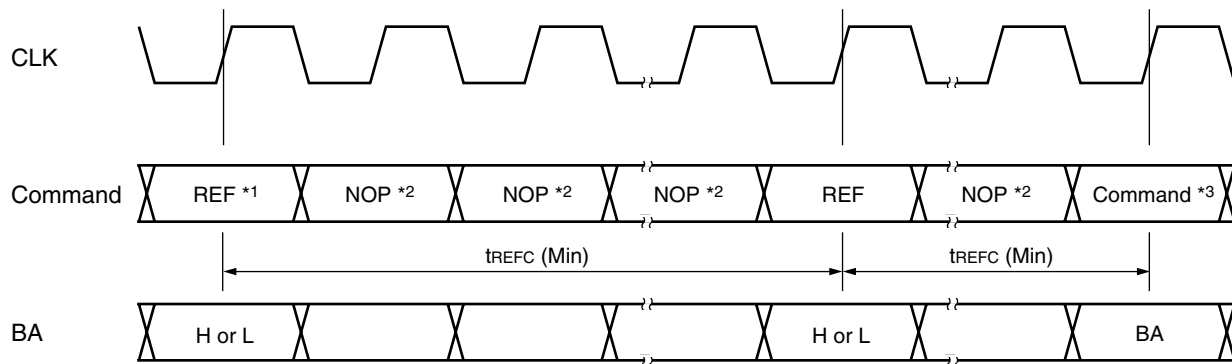

\*1: All banks should be precharged prior to the first Auto-refresh command (REF) .

\*2: Either NOP or DESL command should be asserted within  $t_{REFC}$  period while Auto-refresh mode.

\*3: Any activation command such as ACTV or MRS commands other than REF command should be asserted after  $t_{REFC}$  from the last REF command.

Note: Bank select is ignored at the REF command. The refresh address and bank select are selected by the internal refresh counter.

## 16. Self-Refresh Entry and Exit Timing

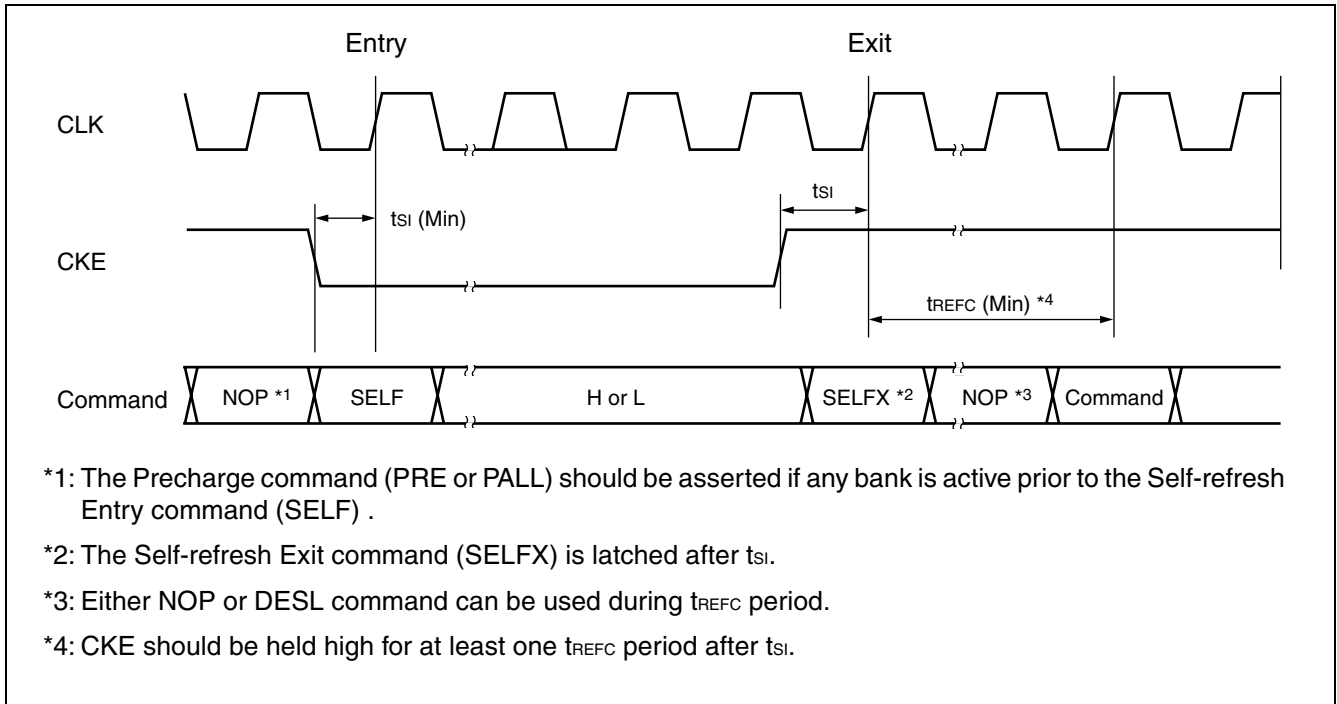

## 17. Mode Register Set Timing

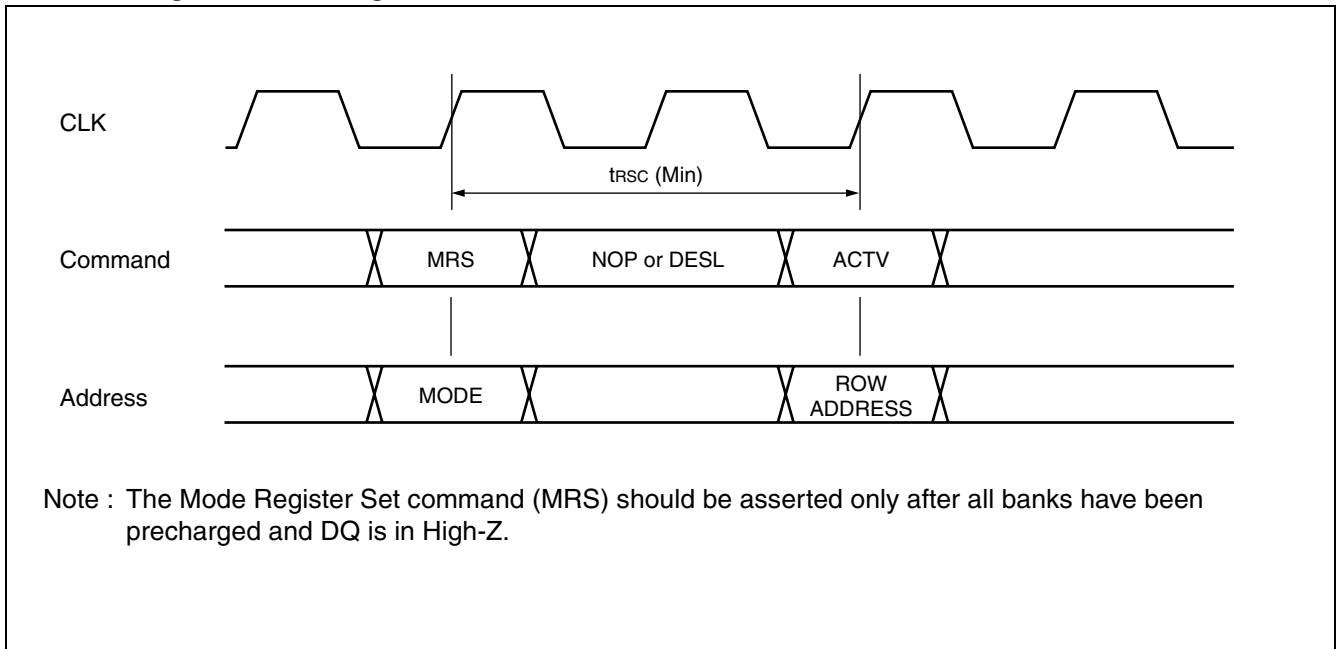

# MB81ES171625/173225-15-X

## ■ ORDERING INFORMATION

Part number	Configuration	Shipping form	Remarks
MB81ES171625-15WFKT-X	512 K word × 16 bit × 2 bank	wafer	
MB81ES173225-15WFKT-X	256 K word × 32 bit × 2 bank	wafer	

**MEMO**



# FUJITSU MICROELECTRONICS LIMITED

Shinjuku Dai-Ichi Seimei Bldg. 7-1, Nishishinjuku 2-chome, Shinjuku-ku,  
Tokyo 163-0722, Japan Tel: +81-3-5322-3347 Fax: +81-3-5322-3387  
<http://jp.fujitsu.com/fml/en/>

*For further information please contact:*

## **North and South America**

FUJITSU MICROELECTRONICS AMERICA, INC.  
1250 E. Arques Avenue, M/S 333  
Sunnyvale, CA 94085-5401, U.S.A.  
Tel: +1-408-737-5600 Fax: +1-408-737-5999  
<http://www.fma.fujitsu.com/>

## **Europe**

FUJITSU MICROELECTRONICS EUROPE GmbH  
Pittlerstrasse 47, 63225 Langen,  
Germany  
Tel: +49-6103-690-0 Fax: +49-6103-690-122  
<http://emea.fujitsu.com/microelectronics/>

## **Korea**

FUJITSU MICROELECTRONICS KOREA LTD.  
206 KOSMO TOWER, 1002 Daechi-Dong,  
Kangnam-Gu, Seoul 135-280  
Korea  
Tel: +82-2-3484-7100 Fax: +82-2-3484-7111  
<http://www.fmk.fujitsu.com/>

## **Asia Pacific**

FUJITSU MICROELECTRONICS ASIA PTE LTD.  
151 Lorong Chuan, #05-08 New Tech Park,  
Singapore 556741  
Tel: +65-6281-0770 Fax: +65-6281-0220  
<http://www.fujitsu.com/sg/services/micro/semiconductor/>

FUJITSU MICROELECTRONICS SHANGHAI CO., LTD.  
Rm.3102, Bund Center, No.222 Yan An Road(E),  
Shanghai 200002, China  
Tel: +86-21-6335-1560 Fax: +86-21-6335-1605  
<http://cn.fujitsu.com/fmc/>

FUJITSU MICROELECTRONICS PACIFIC ASIA LTD.  
10/F., World Commerce Centre, 11 Canton Road  
Tsimshatsui, Kowloon  
Hong Kong  
Tel: +852-2377-0226 Fax: +852-2376-3269  
<http://cn.fujitsu.com/fmc/tw>

All Rights Reserved.

The contents of this document are subject to change without notice.

Customers are advised to consult with sales representatives before ordering.

The information, such as descriptions of function and application circuit examples, in this document are presented solely for the purpose of reference to show examples of operations and uses of FUJITSU MICROELECTRONICS device; FUJITSU MICROELECTRONICS does not warrant proper operation of the device with respect to use based on such information. When you develop equipment incorporating the device based on such information, you must assume any responsibility arising out of such use of the information.

FUJITSU MICROELECTRONICS assumes no liability for any damages whatsoever arising out of the use of the information.

Any information in this document, including descriptions of function and schematic diagrams, shall not be construed as license of the use or exercise of any intellectual property right, such as patent right or copyright, or any other right of FUJITSU MICROELECTRONICS or any third party or does FUJITSU MICROELECTRONICS warrant non-infringement of any third-party's intellectual property right or other right by using such information. FUJITSU MICROELECTRONICS assumes no liability for any infringement of the intellectual property rights or other rights of third parties which would result from the use of information contained herein.

The products described in this document are designed, developed and manufactured as contemplated for general use, including without limitation, ordinary industrial use, general office use, personal use, and household use, but are not designed, developed and manufactured as contemplated (1) for use accompanying fatal risks or dangers that, unless extremely high safety is secured, could have a serious effect to the public, and could lead directly to death, personal injury, severe physical damage or other loss (i.e., nuclear reaction control in nuclear facility, aircraft flight control, air traffic control, mass transport control, medical life support system, missile launch control in weapon system), or (2) for use requiring extremely high reliability (i.e., submersible repeater and artificial satellite).

Please note that FUJITSU MICROELECTRONICS will not be liable against you and/or any third party for any claims or damages arising in connection with above-mentioned uses of the products.

Any semiconductor devices have an inherent chance of failure. You must protect against injury, damage or loss from such failures by incorporating safety design measures into your facility and equipment such as redundancy, fire protection, and prevention of over-current levels and other abnormal operating conditions.

Exportation/release of any products described in this document may require necessary procedures in accordance with the regulations of the Foreign Exchange and Foreign Trade Control Law of Japan and/or US export control laws.

The company names and brand names herein are the trademarks or registered trademarks of their respective owners.