

ASSP For Power Supply Applications (Lithium ion battery charger)

DC/DC Converter IC for Parallel Charging

MB3874/MB3876

■ DESCRIPTION

The MB3874 and MB3876 are parallel charging DC/DC converter ICs suitable for down-conversion, which uses pulse width modulation (PWM) for controlling the output voltage and current independently.

These ICs can dynamically control the secondary battery's charge current by detecting a voltage drop in an AC adapter in order to keep its power constant (dynamically-controlled charging).

The charging method enables quick charging, for example, with the AC adapter during operation of a notebook PC. The IC also enable parallel charging, or charging two batteries at the same time, dramatically reducing the charging time.

With an on-chip output voltage setting resistor which allows the output voltage to be set at high precision, these ICs are best suited as internal battery chargers for notebook PCs.

The MB3874 support 3-cell battery and the MB3876 support 4-cell battery.

These products are covered by US Patent Number 6,147,477.

■ FEATURES

- Detecting a voltage drop in the AC adapter and dynamically controlling the charge current (Dynamically-controlled charging)
- High efficiency : 93 % (In reverse-current preventive diode)
- Wide range of operating supply voltages: 7 V to 25 V

(Continued)

■ PACKAGE

24-pin plastic SSOP

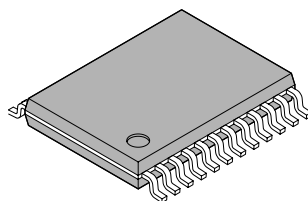

(FPT-24P-M03)

MB3874/MB3876

(Continued)

- Output voltage precision
(Built-in output voltage setting resistor): $\pm 0.8\%$ ($T_a = +25\text{ }^\circ\text{C}$)
- High precision reference voltage source: $4.2\text{ V} \pm 0.8\%$
- Support for frequency setting using an external resistor
(Frequency setting capacitor integrated) :100 kHz to 500 kHz
- Built-in current detector amplifier with wide in-phase input voltage range : 0 V to V_{CC}
- Built-in standby current function: 0 μA (Typ)
- Built-in soft-start function
- Capable of parallel charging (Charging the two battery packs at a time)
- Internal totem-pole output stage supporting P-channel MOS FETs devices

■ PIN ASSIGNMENT

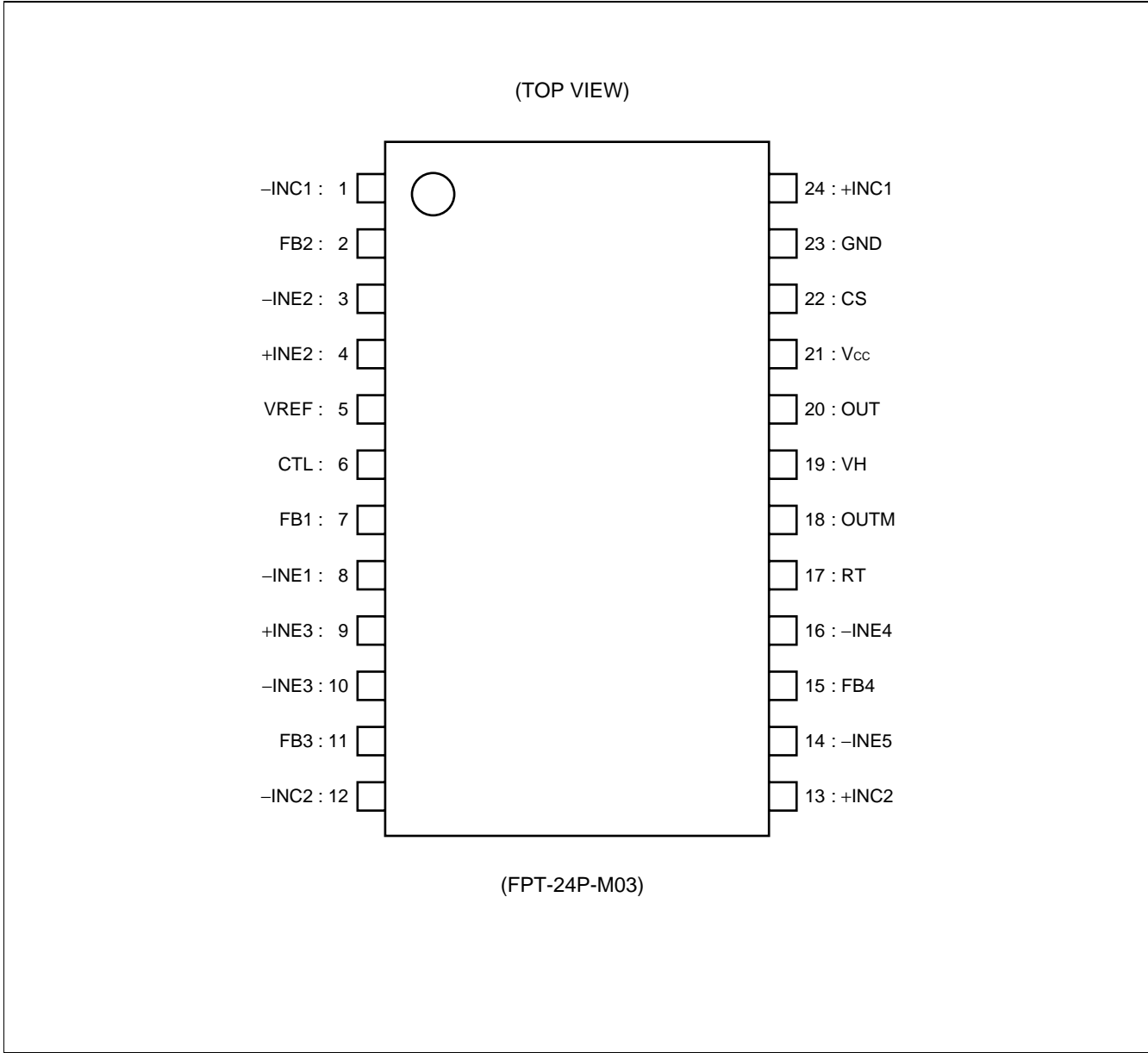

MB3874/MB3876

■ PIN DESCRIPTION

Pin No.	Symbol	I/O	Descriptions
1	-INC1	I	Output voltage feedback input pin.
2	FB2	O	Error amplifier (Error Amp. 2) output pin.
3	-INE2	I	Error amplifier (Error Amp. 2) inverted input pin.
4	+INE2	I	Error amplifier (Error Amp. 2) non-inverted input pin. Input pin for charge current setting voltage
5	VREF	O	Reference voltage output pin.
6	CTL	I	Power supply control pin. Setting the CTL pin low places the IC in the standby mode.
7	FB1	O	Error amplifier (Error Amp. 1) output pin.
8	-INE1	I	Error amplifier (Error Amp. 1) inverted input pin Input pin for dynamically-controlled charging voltage setting
9	+INE3	I	Error amplifier (Error Amp. 3) non-inverted input pin. Input pin for charge current setting voltage
10	-INE3	I	Error amplifier (Error Amp. 3) inverted input pin.
11	FB3	O	Error amplifier (Error Amp. 3) output pin.
12	-INC2	I	Output voltage feedback input pin.
13	+INC2	I	Current detection amplifier (Current Amp. 2) input pin .
14	-INE5	I	Error amplifier (Error Amp. 5) inverted input pin.
15	FB4	O	Error amplifier (Error Amp. 4, 5) output pin.
16	-INE4	I	Error amplifier (Error Amp. 4) inverted input pin.
17	RT	—	Triangular-wave oscillation frequency setting resistor connection pin.
18	OUTM	O	Output pin for dynamically controlled charging identification signal “H” level: Constant-voltage or constant-current charging mode “L” level: Dynamically controlled charging mode
19	VH	O	Power supply pin for FET drive circuit ($V_H = V_{CC} - 5\text{ V}$).
20	OUT	O	High-side FET gate drive pin.
21	V _{CC}	—	Power supply pin for reference power supply and control circuit.
22	CS	—	Soft-start capacitor connection pin.
23	GND	—	Ground pin.
24	+INC1	I	Current detection amplifier (Current Amp. 1) input pin .

■ BLOCK DIAGRAM

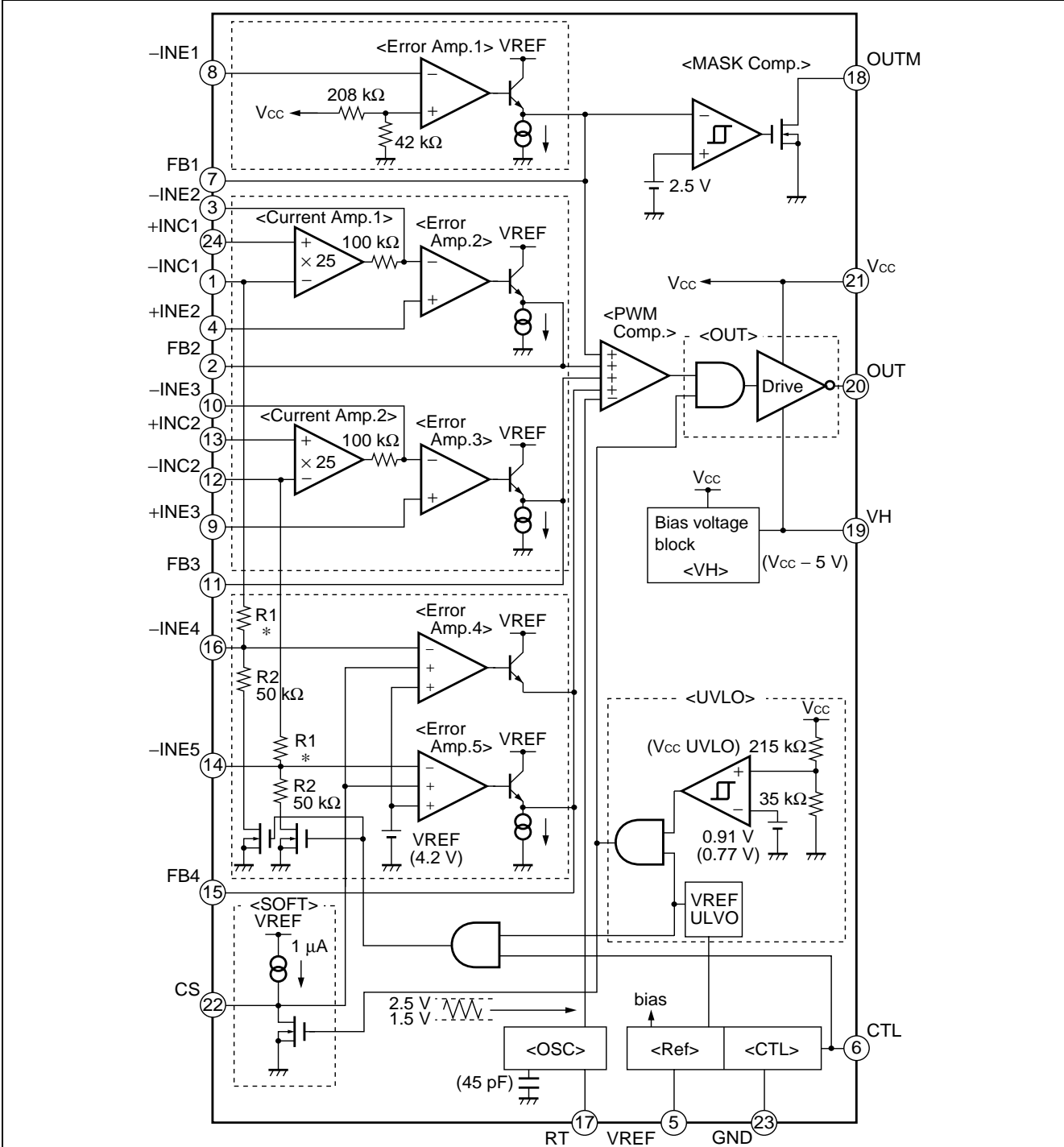

* : MB3874 100 kΩ
 MB3876 150 kΩ

MB3874/MB3876

■ ABSOLUTE MAXIMUM RATINGS

Parameter	Symbol	Conditions	Rating		Unit
			Min	Max	
Power supply voltage	V _{CC}	—	—	28	V
Output terminal current	I _{OUT}	—	—	60	mA
Peak output current	I _{OUT}	Duty ≤ 5% (t = 1 / f _{osc} × Duty)	—	500	mA
OUTM terminal output voltage	V _{OUTM}	—	—	17	V
Power dissipation	P _D	T _a ≤ +25°C	—	740*	mW
Storage temperature	T _{stg}	—	-55	+125	°C

*: The package is mounted on the dual-sided epoxy board (10 cm × 10 cm).

WARNING: Semiconductor devices can be permanently damaged by application of stress (voltage, current, temperature, etc.) in excess of absolute maximum ratings. Do not exceed these ratings.

■ RECOMMENDED OPERATING CONDITIONS

Parameter	Symbol	Conditions	Value			Unit
			Min	Typ	Max	
Power supply voltage	V _{CC}	—	7	—	25	V
Reference voltage output current	I _{REF}	—	-1	—	0	mA
VH pin output current	I _{VH}	—	0	—	30	mA
Input voltage	V _{-INC}	-INC1, -INC2	0	—	17	V
	V _{INE}	-INE1 to -INE5, +INE2	0	—	V _{CC} - 1.8	V
	V _{+INC}	+INC1, +INC2	0	—	V _{CC}	V
CTL pin input voltage	V _{CTL}	—	0	—	25	V
Output current	I _{OUT}	OUT pin	-45	—	45	mA
Peak output current	I _{OUT}	Duty ≤ 5% (t = 1 / f _{osc} × Duty)	-450	—	450	mA
OUTM pin output voltage	V _{OUTM}	—	—	3	15	V
OUTM pin output current	I _{OUTM}	—	—	—	1	mA
Oscillator frequency	f _{osc}	—	100	290	500	kHz
Timing resistor	R _T	—	33	47	130	kΩ
Soft-start capacitor	C _S	—	—	2200	100000	pF
VH pin capacitor	C _{VH}	—	—	0.1	1.0	μF
Reference voltage output capacitor	C _{REF}	—	—	0.1	1.0	μF
Operating ambient temperature	T _a	—	-30	+25	+85	°C

WARNING: The recommended operating conditions are required in order to ensure the normal operation of the semiconductor device. All of the device's electrical characteristics are warranted when the device is operated within these ranges.

Always use semiconductor devices within their recommended operating condition ranges. Operation outside these ranges may adversely affect reliability and could result in device failure.

No warranty is made with respect to uses, operating conditions, or combinations not represented on the data sheet. Users considering application outside the listed conditions are advised to contact their FUJITSU representatives beforehand.

■ ELECTRICAL CHARACTERISTICS

(MB3874 : Ta = +25°C, Vcc = 16 V, VREF = 0 mA)

(MB3876 : Ta = +25°C, Vcc = 19 V, VREF = 0 mA)

Parameter	Symbol	Pin No.	Conditions	Value			Unit	Remarks	
				Min	Typ	Max			
Reference voltage block (Ref)	Output voltage	V _{REF}	5	Ta = +25°C	4.167	4.200	4.233	V	
				Ta = -30°C to +85°C	4.158	4.200	4.242	V	
	Input stability	Line	5	V _{CC} = 7 V to 25 V	—	3	10	mV	
	Load stability	Load	5	V _{REF} = 0 mA to -1 mA	—	1	10	mV	
	Short-circuit output current	I _{OS}	5	V _{REF} = 1 V	-25	-15	-5	mA	
Under voltage lockout protection circuit block (UVLO)	Threshold voltage	V _{TLH}	21	V _{CC} = $\bar{\downarrow}$	6.3	6.6	6.9	V	
		V _{THL}		V _{CC} = $\bar{\uparrow}$	5.3	5.6	5.9	V	
	Hysteresis width	V _H	21	—	0.7	1.0	1.3	V	
	Threshold voltage	V _{TLH}	5	V _{REF} = $\bar{\downarrow}$	2.6	2.8	3.0	V	
		V _{THL}		V _{REF} = $\bar{\uparrow}$	2.4	2.6	2.8	V	
	Hysteresis width	V _H	5	—	0.05	0.20	0.35	V	
Soft-start block (SOFT)	Charge current	I _{CS}	22	—	-1.3	-0.8	-0.5	μA	
Triangular waveform oscillator circuit block (OSC)	Oscillation frequency	f _{OSC}	20	RT = 47 kΩ	260	290	320	kHz	
	Frequency temperature stability	Δf/fdt	20	Ta = -30°C to +85°C	—	1*	—	%	

*: Standard design value.

(Continued)

MB3874/MB3876

(Continued)

(MB3874 : Ta = +25°C, V_{CC} = 16 V, V_{REF} = 0 mA)

(MB3876 : Ta = +25°C, V_{CC} = 19 V, V_{REF} = 0 mA)

Parameter	Symbol	Pin No	Conditions	Value			Unit	Remarks	
				Min	Typ	Max			
Error amplifier block (Error Amp.1)	Threshold voltage	V _{TH}	21	FB1 = 2 V, -INE1 = 2.35 V	14.00	14.20	14.40	V	MB3874
				FB1 = 2 V, -INE1 = 2.83 V	16.80	17.10	17.40	V	MB3876
	Input pin current	I _{IN}	8	-INE1 = 0 V	-100	-30	—	nA	
	Voltage gain	A _V	7	DC	—	100*	—	dB	
	Frequency bandwidth	BW	7	A _V = 0 dB	—	2.0*	—	MHz	
	Output voltage	V _{FBH}	7	—	3.9	4.1	—	V	
		V _{FBL}	7	—	—	20	200	mV	
	Output source current	I _{SOURCE}	7	FB1 = 2 V	—	-2.0	-0.6	mA	
Output sink current	I _{SINK}	7	FB1 = 2 V	150	300	—	μA		
Error amplifier block (Error Amp.2, 3)	Input offset voltage	V _{IO}	3,4 9,10	FB2 = FB3 = 2 V	—	1*	—	mV	
	Input pin current	I _{INE}	4,9	+INE2 = +INE3 = 0 V	-100	-30	—	nA	
	Common mode input voltage range	V _{CM}	3,4 9,10	—	0	—	V _{CC} -1.8	V	
	Voltage gain	A _V	2, 11	DC	—	100*	—	dB	
	Frequency bandwidth	BW	2, 11	A _V = 0 dB	—	2.0*	—	MHz	
	Output voltage	V _{FBH}	2, 11	—	3.9	4.1	—	V	
		V _{FBL}	2, 11	—	—	20	200	mV	
	Output source current	I _{SOURCE}	2, 11	FB2 = FB3 = 2 V	—	-2.0	-0.6	mA	
Output sink current	I _{SINK}	2, 11	FB2 = FB3 = 2 V	150	300	—	μA		

*: Standard design value.

(Continued)

MB3874/MB3876

(Continued)

(MB3874 : Ta = +25°C, Vcc = 16 V, VREF = 0 mA)

(MB3876 : Ta = +25°C, Vcc = 19 V, VREF = 0 mA)

Parameter	Symbol	Pin No	Conditions	Value			Unit	Remarks	
				Min	Typ	Max			
Error amplifier block (Current Amp.4, 5)	Threshold voltage	V _{TH}	1, 12	FB4 = 2 V, Ta = +25 °C	12.500	12.600	12.700	V	MB3874
				16.666	16.800	16.934	V	MB3876	
			FB1 = 2 V, Ta = -30 °C to +85 °C	12.474	12.600	12.726	V	MB3874	
				16.632	16.800	16.968	V	MB3876	
	Input current	I _{INEH}	1, 12	-INC1 = -INC2 = 12.6 V	—	84	150	μA	MB3874
				-INC1 = -INC2 = 16.8 V	—	84	150	μA	MB3876
		I _{INEL}	1, 12	V _{CC} = 0 V, -INC1 = -INC2 = 12.6 V	—	0	1	μA	MB3874
				V _{CC} = 0 V, -INC1 = -INC2 = 16.8 V	—	0	1	μA	MB3876
	Input resistor	R ₁	1, 12	—	70	100	130	kΩ	MB3874
					105	150	195	kΩ	MB3876
		R ₂	14, 16	—	35	50	65	kΩ	
	Voltage gain	A _V	15	DC	—	100*	—	dB	
Frequency bandwidth	BW	15	AV = 0 dB	—	2.0*	—	MHz		
Output voltage	V _{FBH}	15	—	3.9	4.1	—	V		
	V _{FBL}	15	—	—	20	200	mV		
Output source current	I _{SOURCE}	15	FB4 = 2 V	—	-2.0	-0.6	mA		
Output sink current	I _{SINK}	15	FB4 = 2 V	150	300	—	μA		

*: Standard design value.



(Continued)

MB3874/MB3876

(Continued)

(MB3874 : Ta = +25°C, V_{CC} = 16 V, V_{REF} = 0 mA)

(MB3876 : Ta = +25°C, V_{CC} = 19 V, V_{REF} = 0 mA)

Parameter	Symbol	Pin No.	Conditions	Value			Unit	Remarks	
				Min	Typ	Max			
Current detection amplifier block (Current Amp.1, 2)	Input current	I _{+INCH}	13, 24	+INC1= +INC2=12.7 V, -INC1= -INC2=12.6 V	—	10	20	μA	MB3874
				+INC1= +INC2=16.9 V, -INC1= -INC2=16.8 V	—	10	20	μA	MB3876
	I _{+INCL}	13, 24	+INC1= +INC2= 0.1 V, -INC1= -INC2= 0 V	-130	-65	—	μA		
	Current detection voltage	V _{-INE1}	3, 10	+INC1= +INC2=12.7 V, -INC1= -INC2=12.6 V	2.25	2.50	2.75	V	MB3874
				+INC1= +INC2=16.9 V, -INC1= -INC2=16.8 V	2.25	2.50	2.75	V	MB3876
		V _{-INE2}	3, 10	+INC1= +INC2=12.63V, -INC1= -INC2=12.6 V	0.50	0.75	1.00	V	MB3874
				+INC1= +INC2=16.83 V, -INC1= -INC2=16.8 V	0.50	0.75	1.00	V	MB3876
		V _{-INE3}	3, 10	+INC1= +INC2= 0.1 V , -INC1= -INC2= 0 V	1.25	2.50	3.75	V	
		V _{-INE4}	3, 10	+INC1= +INC2= 0.03 V, -INC1= -INC2= 0 V	0.125	0.750	1.375	V	
	Common mode input voltage range	V _{CM}	1, 12, 13, 24	—	0	—	V _{CC}	V	
	Voltage gain	A _V	3, 10	+INC1= +INC2=12.7 V, -INC1= -INC2=12.6 V	22.5	25	27.5	V/V	MB3874
				+INC1= +INC2=16.9 V, -INC1= -INC2=16.8 V	22.5	25	27.5	V/V	MB3876
Output voltage	V _{OUTCH}	3, 10	—	3.9	4.1	—	V		
	V _{OUTCL}	3, 10	—	—	20	200	mV		
PWM comparator block (PWM Comp.)	Threshold voltage	V _{TL}	2, 7, 11, 15	Duty cycle = 0 %	1.4	1.5	—	V	
		V _{TH}	2, 7, 11, 15	Duty cycle = 100 %	—	2.5	2.6	V	
Constant power detection block (MASK Comp.)	Threshold voltage	V _{TLH}	18	FB1 = 	2.7	2.8	2.9	V	
		V _{THL}	18	FB1 = 	2.4	2.5	2.6	V	
	Hysteresis width	V _H	18	—	0.2	0.3	0.4	V	
	Output leak current	I _{LEAK}	18	OUTM = 5 V	—	0	1	μA	
	Output voltage	V _{OL}	18	OUTM = 1 mA	—	0.15	0.4	V	

(Continued)

MB3874/MB3876

(Continued)

(MB3874 : Ta = +25°C, V_{CC} = 16 V, V_{REF} = 0 mA)

(MB3876 : Ta = +25°C, V_{CC} = 19 V, V_{REF} = 0 mA)

Parameter	Symbol	Pin No.	Conditions	Value			Unit	Remarks	
				Min	Typ	Max			
Output block (OUT)	Output source current	I _{SOURCE}	20	OUT = 11 V, Duty ≤ 5 % (t = 1/fosc × Duty)	—	-200*	—	mA	MB3874
				OUT = 14 V, Duty ≤ 5 % (t = 1/fosc × Duty)	—	-200*	—	mA	MB3876
	Output sink current	I _{SINK}	20	OUT = 16 V, Duty ≤ 5 % (t = 1/fosc × Duty)	—	200*	—	mA	MB3874
				OUT = 19 V, Duty ≤ 5 % (t = 1/fosc × Duty)	—	200*	—	mA	MB3876
	Output ON resistor	R _{OH}	20	OUT = -45 mA	—	8.0	16.0	Ω	
		R _{OL}	20	OUT = 45 mA	—	6.5	13.0	Ω	
	Rise time	tr1	20	OUT = 3300 pF (Equivalent to Si4435DY)	—	70*	—	ns	
	Fall time	tf1	20	OUT = 3300 pF (Equivalent to Si4435DY)	—	60*	—	ns	
Control block (CTL)	CTL input voltage	V _{ON}	6	Active mode	2.0	—	25.0	V	
		V _{OFF}	6	Standby mode	0	—	0.8	V	
	Input current	I _{CTLH}	6	CTL = 5 V	—	100	200	μA	
		I _{CTL}	6	CTL = 0 V	—	0	1	μA	
Bias voltage block (VH)	Output voltage	VH	19	V _{CC} = 7 V to 25 V, VH = 0 to 30 mA	V _{CC} - 5.5	V _{CC} - 5.0	V _{CC} - 4.5	V	
General	Standby current	I _{CCS}	21	CTL = 0 V	—	0	10	μA	
	Power supply current	I _{CC}	21	CTL = 5 V	—	6.0	9.0	mA	MB3874
					—	6.5	9.5	mA	MB3876

*: Standard design value

TYPICAL CHARACTERISTICS

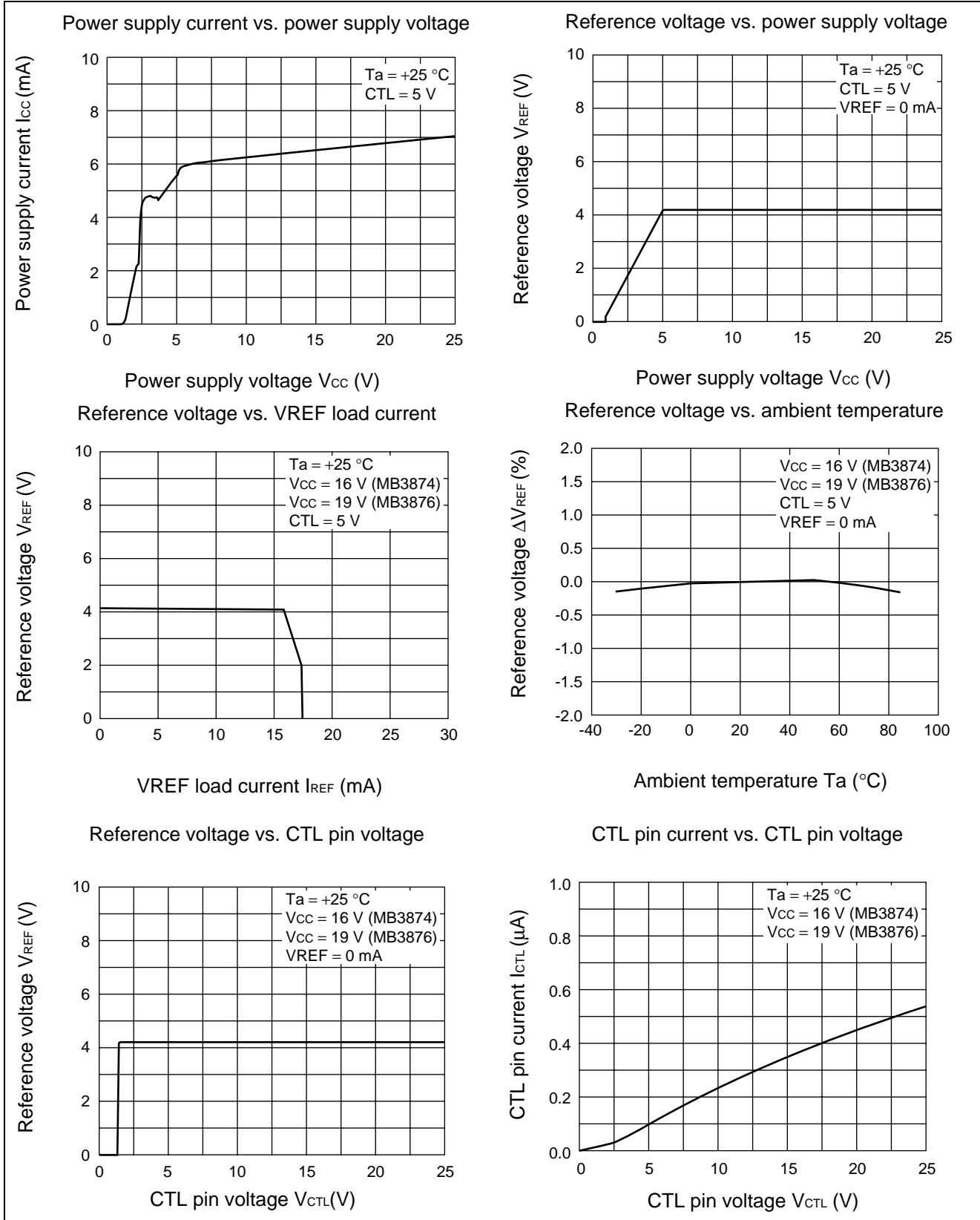

(Continued)

(Continued)

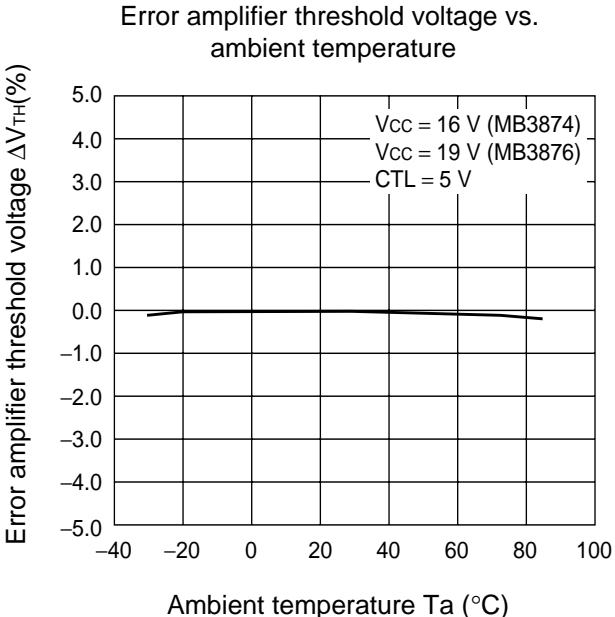
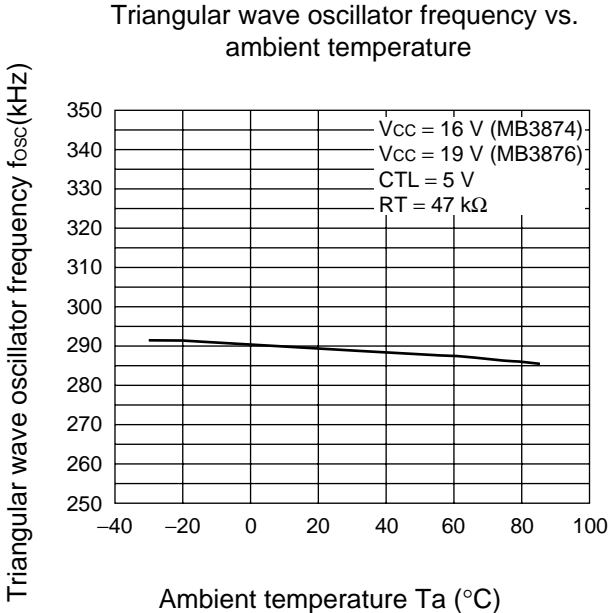
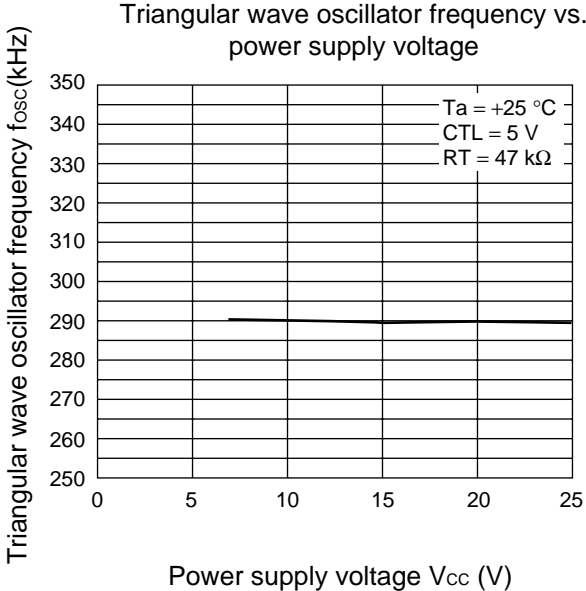
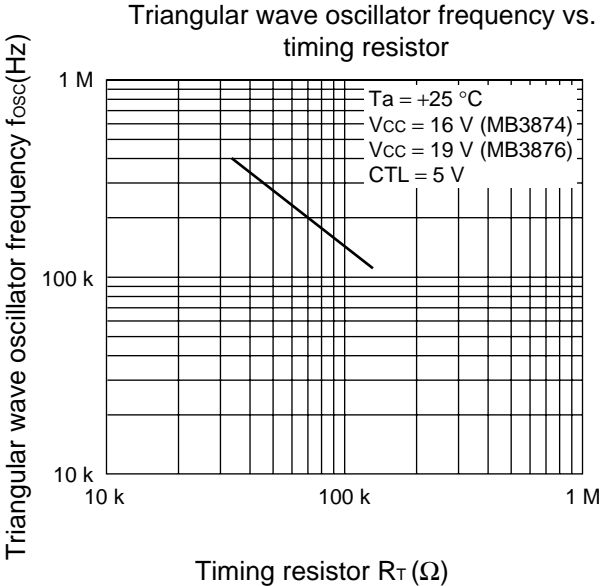

MB3874/MB3876

(Continued)

Error amplifier gain and phase vs. frequency

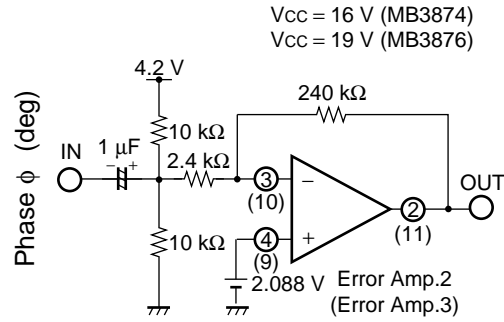
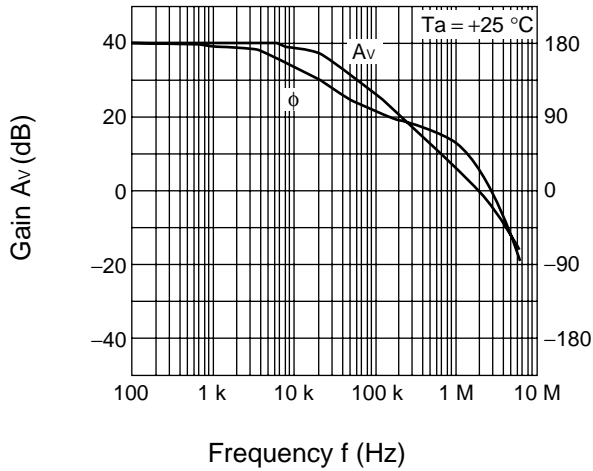

Current detection amplifier gain and phase vs. frequency

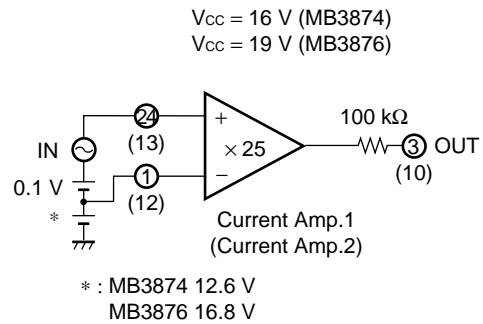
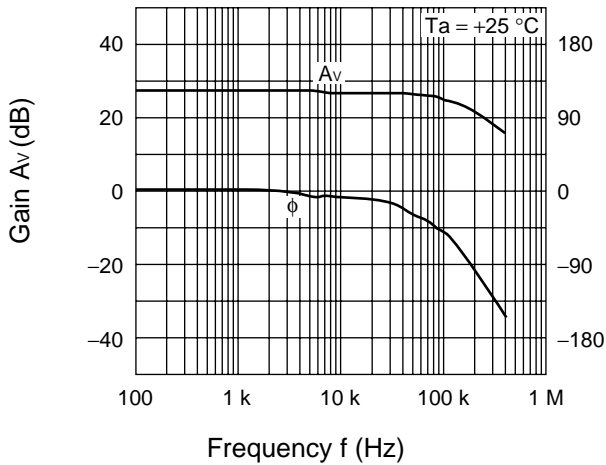

Power dissipation vs. ambient temperature

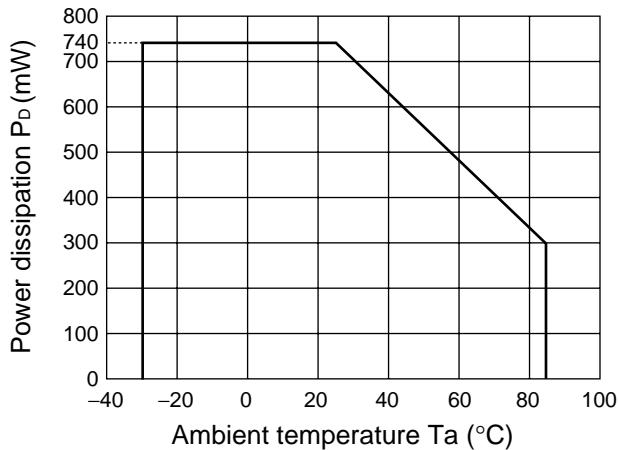

■ FUNCTIONAL DESCRIPTION

1. DC/DC Converter Unit

(1) Reference voltage block (Ref)

The reference voltage generator uses the voltage supplied from the Vcc terminal (pin 21) to generate a temperature-compensated, stable voltage (≈ 4.2 V) used as the reference supply voltage for the IC's internal circuitry.

The reference voltage can be output, up to 1 mA, to an external device through the VREF terminal (pin 5).

(2) Triangular wave oscillator block (OSC)

The triangular wave oscillator generates a triangular waveform with a frequency setting resistor connected to the internal frequency setting capacitor via the RT terminal (pin 17).

The triangular wave is input to the PWM comparator on the IC.

(3) Error amplifier block (Error Amp.1)

This error amplifier (Error Amp.1) detects a voltage drop in the AC adapter and outputs a PWM control signal as well as a signal to the dynamically controlled charging detection block (MASK Comp.).

In addition, an arbitrary loop gain can be set by connecting a feedback resistor and capacitor from the FB1 terminal (pin 7) to the -INE1 terminal (pin 8) of the error amplifier, enabling stable phase compensation to the system.

(4) Error amplifier block (Error Amp.2, 3)

These error amplifiers (Error Amp.2, Error Amp.3) detect the output signals from the current detector amplifiers (Current Amp.1, Current Amp.2), compare them with the +INE2 terminal (pin 4) and +INE3 terminal (pin 9), and output PWM control signals to control the charge current.

In addition, these amplifiers allow an arbitrary loop gain to be set by connecting a feedback resistor and capacitor from the FB2 terminal (pin 2) to -INE2 terminal (pin 3) and from the FB3 terminal (pin 11) to -INE3 terminal (pin 10) of the error amplifiers, enabling stable phase compensation to the system.

(5) Error amplifier block (Error Amp.4, 5)

This error amplifier (Error Amp.4, Error Amp.5) detects the output voltage from the switching regulator and outputs the PWM control signal. The error amplifier inverted input pin is connected to the output voltage setting resistor in the IC, eliminating the need for an external resistor for setting the output voltage. The MB3874 and MB3876 are set to output voltage of 12.6 V (for a 3-cell battery) and 16.8 V (for a 4-cell battery), respectively; these ICs are suitable for use in equipment that uses a lithium-ion battery.

In addition, an arbitrary loop gain can be set by connecting a feedback resistor and capacitor from the FB4 terminal (pin 15) to the -INE4 terminal (pin 16) to the -INE5 terminal (pin 14) of the error amplifier, enabling stable phase compensation to the system.

Connecting a soft-start capacitor to the CS terminal (pin 22) prevents surge currents when the IC is turned on. Using an error amplifier for soft-start detection makes the soft-start time constant, independent of the output load.

(6) Current detector amplifier block (Current Amp.1, 2)

The current detection amplifier (Current Amp.1, Current Amp.2) detects a voltage drop which occurs between both ends of the output sense resistor (RS1) due to the flow of the charge current, using the +INC1 terminal (pin 24) and

-INC1 terminal (pin 1). Then it outputs the signal amplified by 25 times to the error amplifier (Error Amp.2) at the next stage. The amplifiers also detect a voltage drop which occurs at both ends of the output sense resistor

(RS2) using the +INC2 terminal (pin 13) and –INC2 terminal (pin 12) and output the signal amplified by 25 times to the error amplifier (Error Amp. 3) at the next stage.

(7) PWM comparator block (PWM Comp.)

The PWM comparator circuit is a voltage-pulse width converter for controlling the output duty of the error amplifiers (Error Amp. 1 to Error Amp. 5) depending on their output voltage.

The PWM comparator circuit compares the triangular wave generated by the triangular wave oscillator to the error amplifier output voltage and turns on the external output transistor during the interval in which the triangular wave voltage is lower than the error amplifier output voltage.

(8) Output block (OUT)

The output circuit uses a totem-pole configuration capable of driving an external P-channel MOS FET.

The output “L” level sets the output amplitude to 5 V (typical) using the voltage generated by the bias voltage block (VH).

This results in increasing conversion efficiency and suppressing the withstand voltage of the connected external transistor in a wide range of input voltages.

(9) Control block (CTL)

Setting the CTL terminal (pin 6) low places the IC in the standby mode. (The supply current is 10 μ A at maximum in the standby mode.)

(10) Bias voltage block (VH)

The bias voltage circuit outputs $V_{cc} - 5$ V (typical) as the minimum potential of the output circuit. In the standby mode, this circuit outputs the potential equal to V_{cc} .

2. Protection Functions

Low- V_{cc} malfunction preventive circuit (UVLO)

The transient state or a momentary decrease in supply voltage or internal reference voltage (V_{REF}), which occurs when the power supply is turned on, may cause malfunctions in the control IC, resulting in breakdown or degradation of the system. To prevent such malfunction, the low- V_{cc} malfunction preventive circuit detects a supply voltage or internal reference voltage drop and fixes the OUT terminal (pin 20) to the “H” level. The system restores voltage supply when the supply voltage or internal reference voltage reaches the threshold voltage of the low- V_{cc} malfunction preventive circuit.

3. Soft-start Function

Soft-start block (SOFT)

Connecting a capacitor to the CS terminal (pin 22) prevents surge currents when the IC is turned on. Using an error amplifier for soft-start detection makes the soft-start time constant, independent of the output load of the DC/DC converter.

4. Additional Functions

Dynamically controlled charging detection block (MASK Comp.)

The dynamically controlled charging detection block (MASK Comp.) usually output the “H” level signal. The OUTM signal becomes low (“L” level) when the output voltage of the error amplifier (Error Amp. 1) that detects the input voltage (V_{cc}) becomes lower than the crest value (2.5 V) of the triangular waveform generator (OSC).

The OUTM signal return high (“H” level) when the input voltage reaches 2.8 V or more.

■ METHOD OF SETTING THE CHARGING CURRENT

The charge current (output control current) value can be set with the voltage at the +INE2, +INE3 terminal.

If a current exceeding the set value attempts to flow, the charge voltage drops according to the set current value.

Battery 1 charge current setting voltage : +INE2

$$+INE2 (V) = 25 \times I1 (A) \times R_{s1} (\Omega)$$

Battery 2 charge current setting voltage : +INE3

$$+INE3 (V) = 25 \times I2 (A) \times R_{s2} (\Omega)$$

■ METHOD OF SETTING THE SOFT-START TIME

Upon activation, the IC starts charging the capacitor (Cs) connected to the CS terminal .

The error amplifier causes soft-start operation to be performed with the output voltage in proportion to the CS pin voltage regardless of the load current of the DC/DC converter.

Soft-start time ts (Time taken for the output voltage to reach 100 %)

$$t_s (s) \approx 4.2 \times C_s (\mu F)$$

■ METHOD OF SETTING THE TRIANGULAR WAVE OSCILLATOR FREQUENCY SETTING

The triangular wave oscillator frequency can be set by the timing resistor (RT) connected the RT terminal (pin 17).

Triangular wave oscillator frequency fosc

$$f_{osc} (kHz) \approx 14444 / R_T (k\Omega)$$

■ AC ADAPTER VOLTAGE DETECTION

When partial potential point A of the AC adapter voltage (Vcc) becomes lower than the voltage at the -INE1 pin, the IC enters the constant-power mode to reduce the charge current in order to keep AC adapter power constant.

AC adapter detected voltage setting Vth

$$V_{th} (V) = (208k + 42k) / 42k \times -INE1 \approx 5.95 \times -INE1$$

- INE1 setting voltage range : 1.176 V to 4.2 V (equivalent to 7 V to 25 V for Vcc)

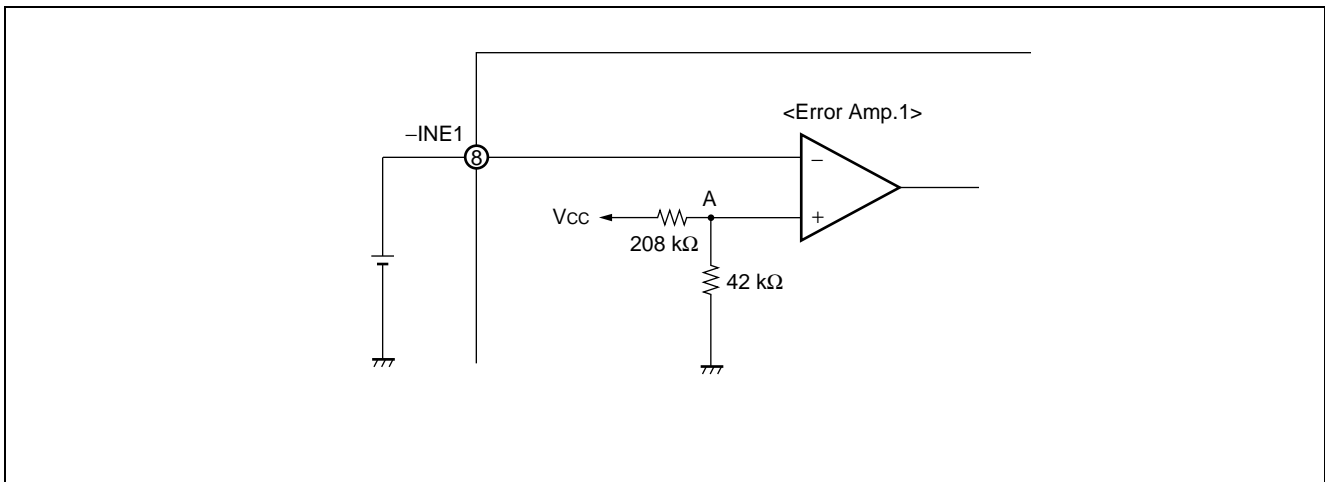

MB3874/MB3876

OPERATION TIMING DIAGRAM

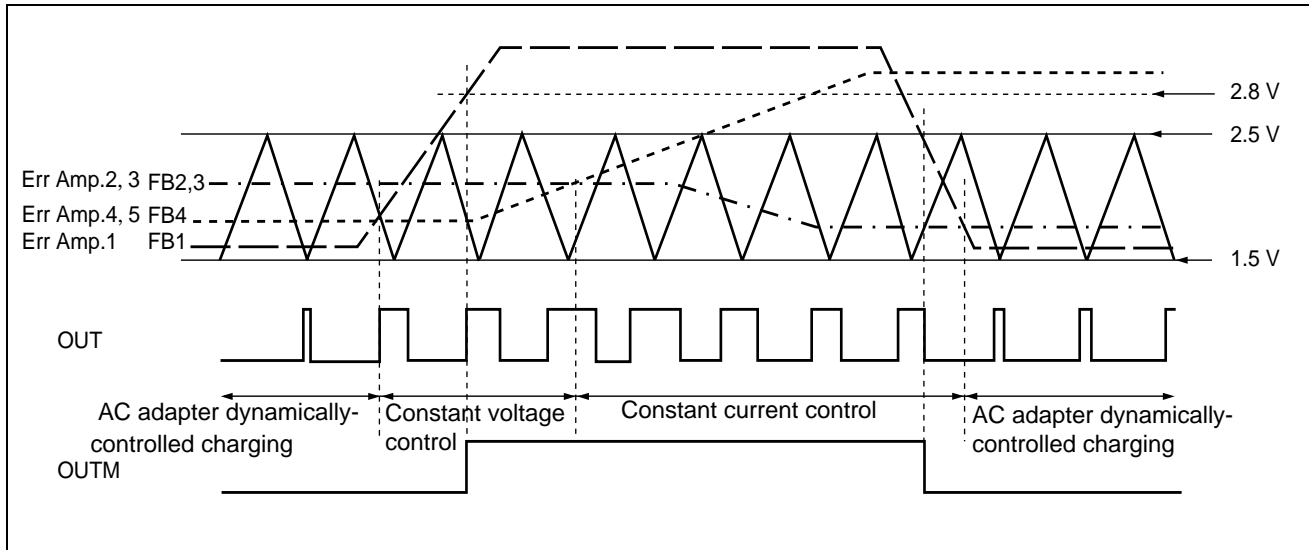

About the OUTM signal

The OUTM signal becomes low when the output voltage of the error amplifier (Error Amp. 1) that detects the AC adapter voltage (V_{CC}) becomes lower than the crest value (2.5 V) of the triangular waveform generator (OSC).

If the sum of the current consumption by the system and that by the charger exceeds the current capacity of the AC adapter, the IC detects a voltage drop in the AC adapter output and switches to the dynamically-controlled charging mode from C.V.C.C (constant-voltage/constant-current charging control) mode.

In the dynamically-controlled charging mode, the OUTM pin outputs the L level signal to distinguish between the case in which the charge current has become small as the system current consumption has increased and the case in which it has become small as battery charging has been finished.

L: Dynamically-controlled charging

H: C.V.C.C (constant-voltage/constant-current charging control) or IC standby mode

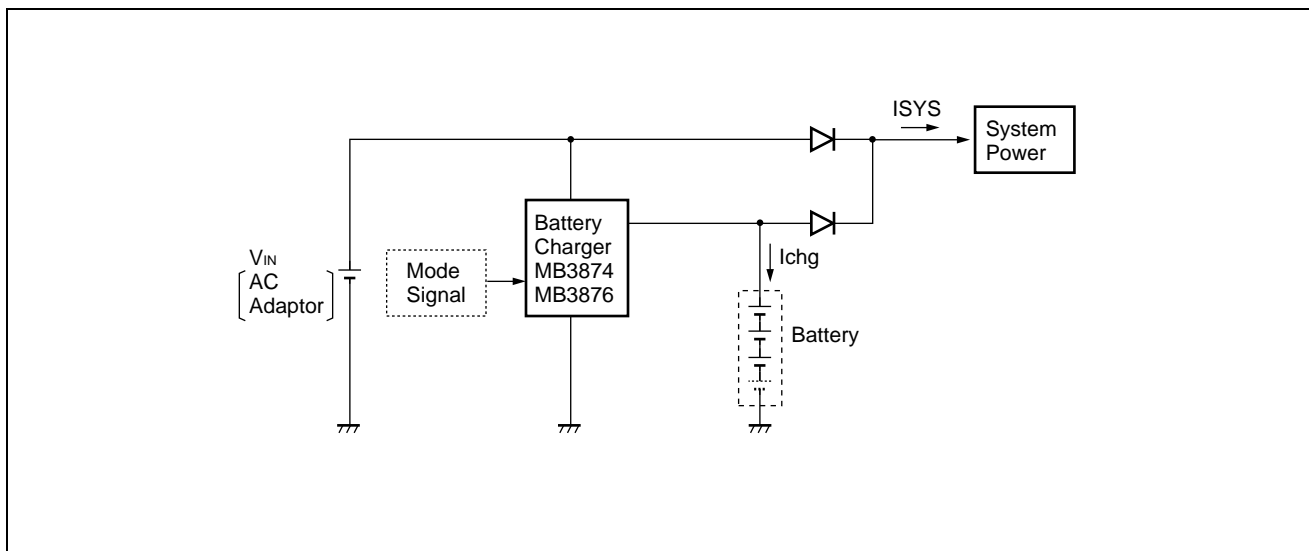

■ NOTE ON AN EXTERNAL REVERSE-CURRENT PREVENTIVE DIODE

If there is an imbalance in charge current (I_1 , I_2) under constant-voltage control, voltage is controlled at the side with a lower battery voltage and thus the battery voltage at one side is higher than that at the other by the voltage difference between the reverse-current preventive diodes (D_1 , D_2) and between the sense resistors (R_{s1} , R_{s2})

Pay attention to the voltage/current characteristics of the reverse-current preventive diode (D_1 , D_2) not to let it exceed the overcharge stop voltage.

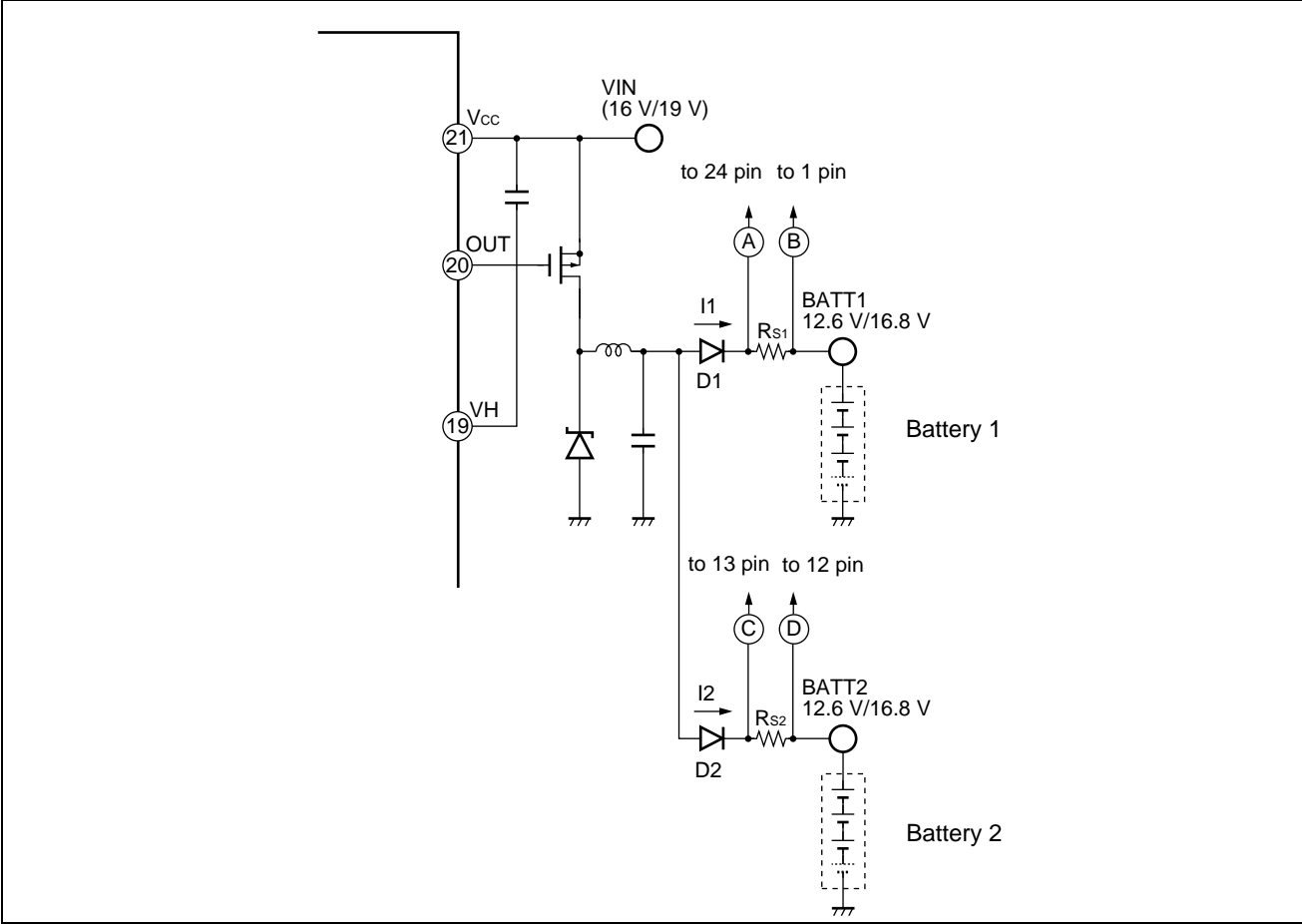

MB3874/MB3876

APPLICATION EXAMPLE

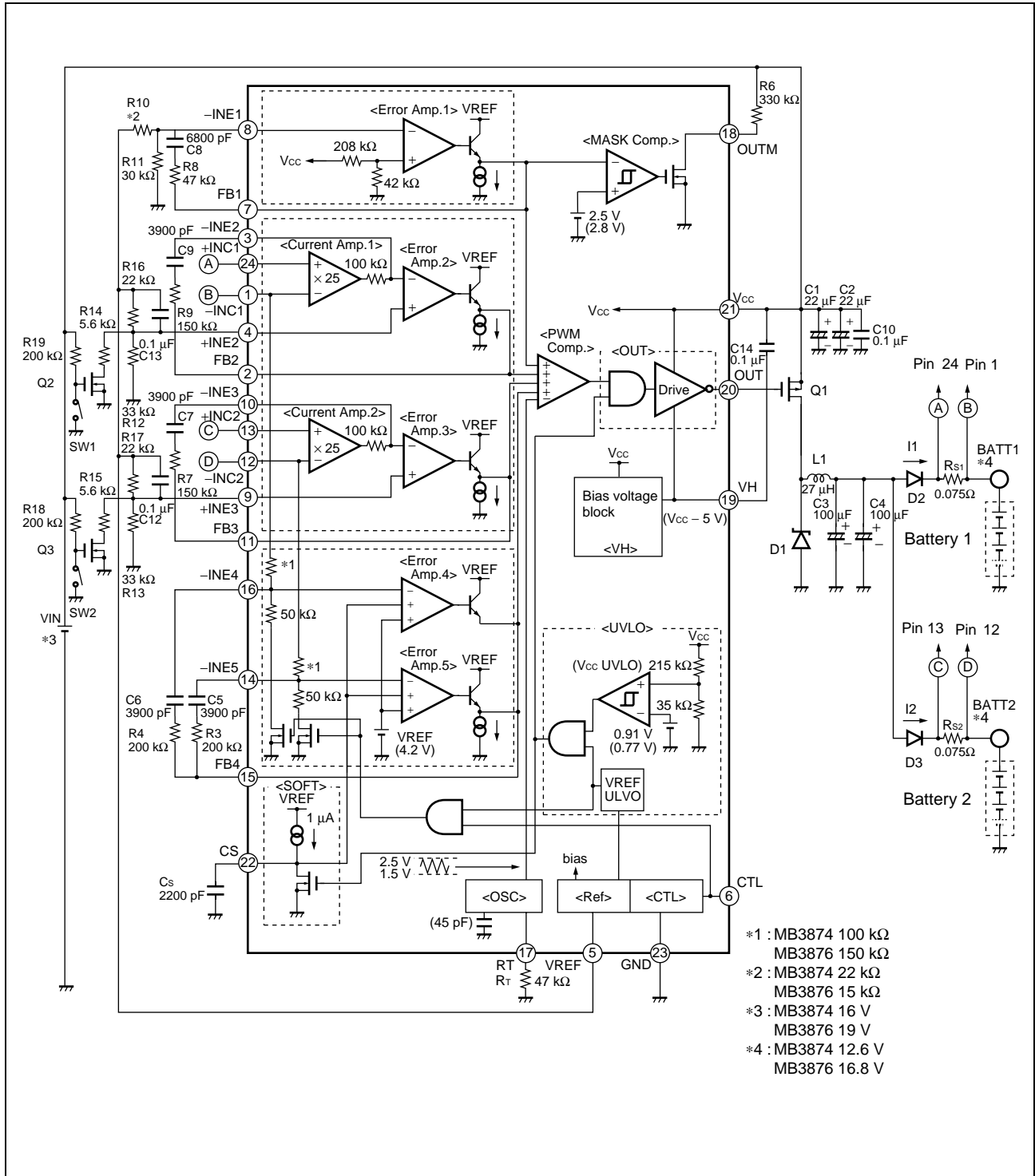

■ PARTS LIST

COMPONENT	ITEM	SPECIFICATION		VENDOR	PARTS NO.
Q1	FET	Si4435DY		VISHAY SILICONIX	Si4435DY
Q2, Q3	FET	2N7002		VISHAY SILICONIX	2N7002
D1	Diode	MBRS130LT3		MOTOROLA	MBRS130LT3
D2, D3	Diode	RB151L-40F		ROHM	RB151L-40F
L1	Coil	27 μ H	2.8 A, 80 m Ω	SUMIDA	CDRH127-27 μ H
C1, C2	OS Condensor	22 μ F	25 V (10 %)	—	—
C3, C4	OS Condensor	100 μ F	16 V (10 %)		
C5, C6	Ceramics Condensor	3900 pF	25 V (10 %)		
C7	Ceramics Condensor	3900 pF	10 %		
C8	Ceramics Condensor	6800 pF	10 %		
C9	Ceramics Condensor	3900 pF	10 %		
C10	Ceramics Condensor	0.1 μ F	10 %		
Cs	Ceramics Condensor	2200 μ F	25 V		
C12, C13	Ceramics Condensor	0.1 μ F	16 V		
C14	Ceramics Condensor	0.1 μ F	16 V		
R1, R2	Resistor	0.075 Ω	1.0 %		
R3, R4	Resistor	200 k Ω	1.0 %		
R _T	Resistor	47 k Ω	1.0 %		
R6	Resistor	330 k Ω	5 %		
R7	Resistor	150 k Ω	1.0 %		
R8	Resistor	47 k Ω	1.0 %		
R9	Resistor	150 k Ω	1.0 %		
R10	Resistor	22 k Ω	0.5 %		
R11, R12	Resistor	30 k Ω	0.5 %		
R13	Resistor	30 k Ω	0.5 %		
R14, R15	Resistor	5.6 k Ω	0.5 %		
R16, R17	Resistor	22 k Ω	0.5 %		
R18, R19	Resistor	200 k Ω	5 %		

Note: VISHAY SILICONIX : VISHAY Intertechnology, Inc.

MOTOROLA : Motorola Japan Ltd.

ROHM : RHOM CO., LTD

SUMIDA : SUMIDA ELECTRIC CO., Ltd.

MB3874/MB3876

REFERENCE DATA

• MB3874

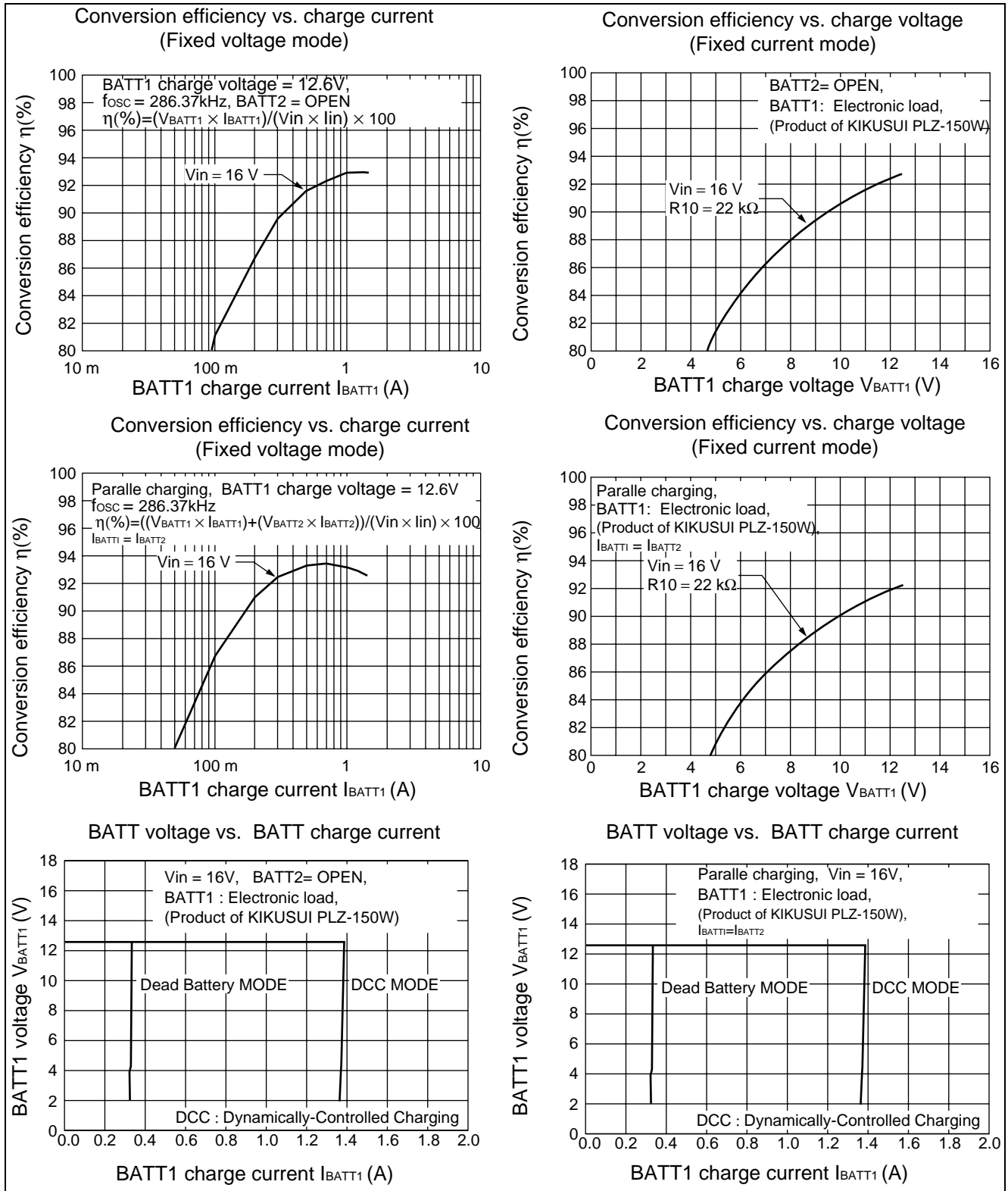

Note: KIKUSUI : KIKUSUI Electronics Corp.

(Continued)

Soft-start operating waveforms

Vin = 16 V
Load : BATT1 = 20 Ω
- INE1 = 0 V
BATT2 = OPEN

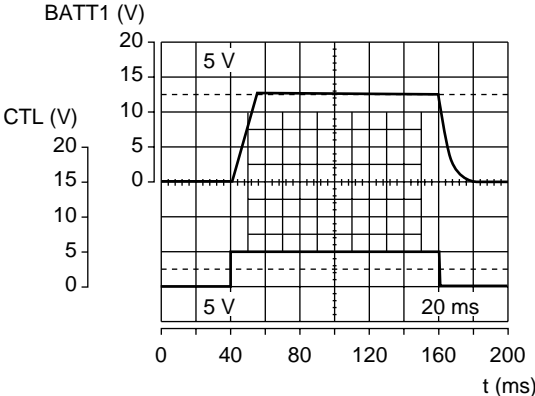

DC/DC converter switching waveforms

Vin = 16 V
Fosc = 286.7 kHz
Load : BATT1 = 1 A
BATT2 = OPEN

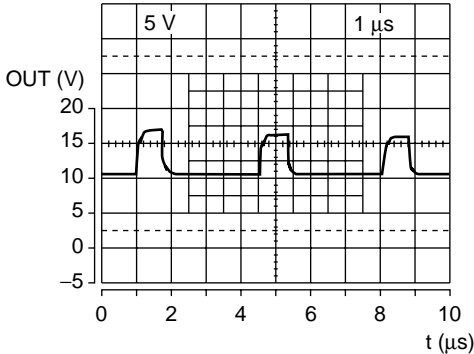

MB3874/MB3876

• MB3876

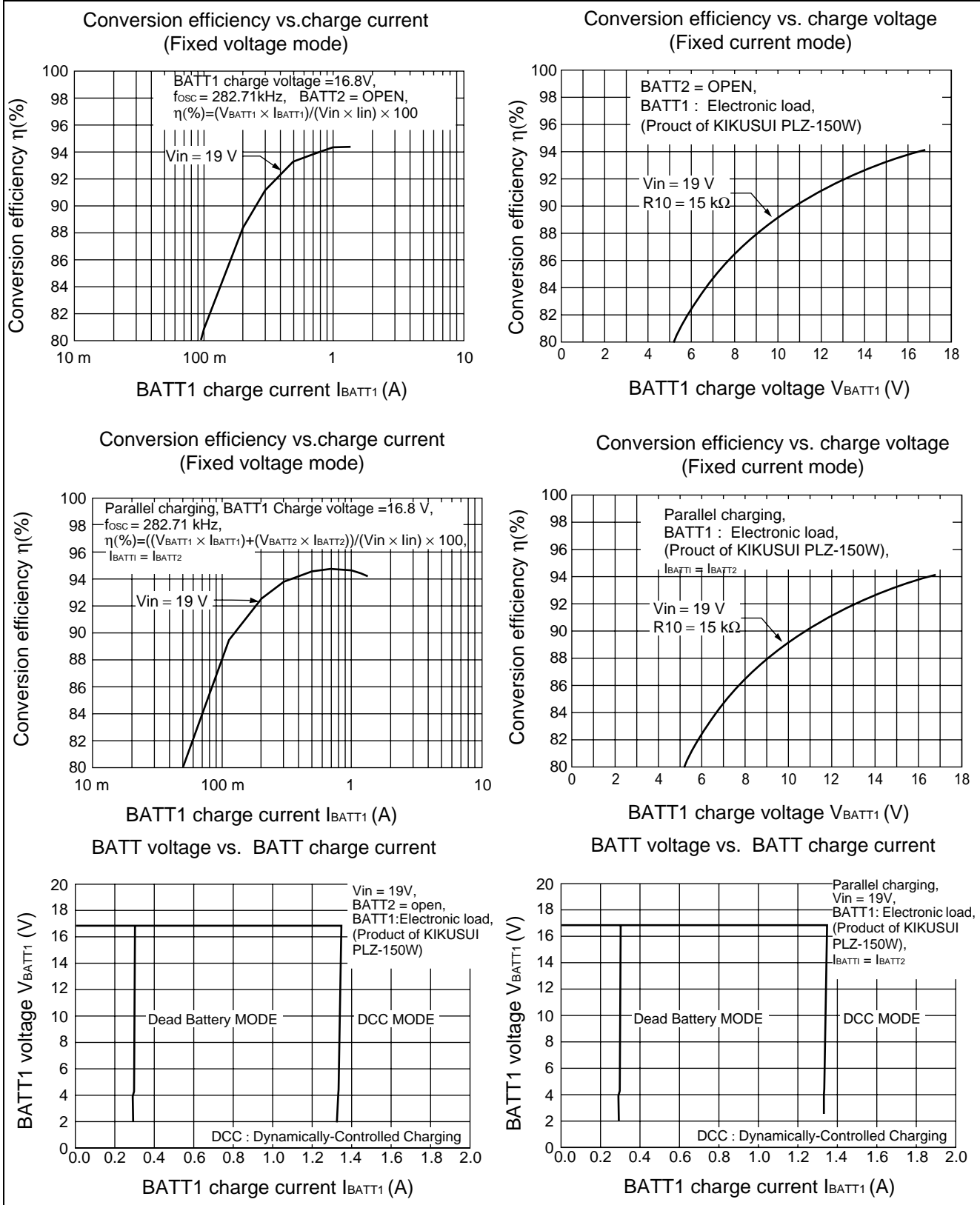

Note: KIKUSUI : KIKUSUI Electronics Corp.

(Continued)

Soft-start operating waveforms

V_{in} = 19 V
Load : BATT1 = 50 Ω
- INE1 = 0 V
BATT2 = OPEN

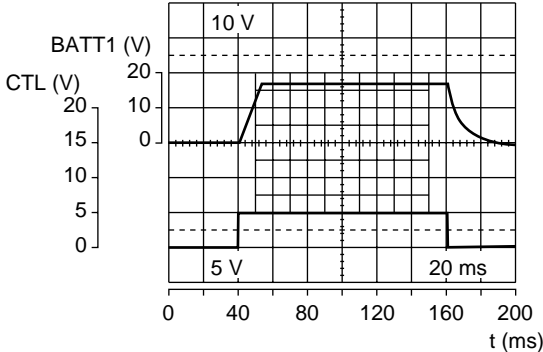

DC/DC converter switching waveforms

V_{in} = 19 V
F_{osc} = 282.6 kHz
Load : BATT1 = 1 A
BATT2 = OPEN

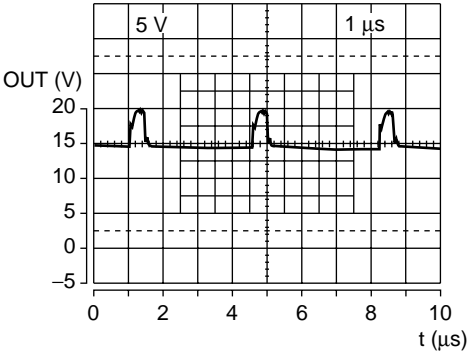

MB3874/MB3876

■ USAGE PRECAUTIONS

1. Never use settings exceeding maximum rated conditions.

Exceeding maximum rated conditions may cause permanent damage to the LSI.
Also, it is recommended that recommended operating conditions be observed in normal use.
Exceeding recommended operating conditions may adversely affect LSI reliability.

2. Use this device within recommended operating conditions.

Recommended operating conditions are values within which normal LSI operation is warranted. Standard electrical characteristics are warranted within the range of recommended operating conditions and within the listed conditions for each parameter.

3. Printed circuit board ground lines should be set up with consideration for common impedance.

4. Take appropriate static electricity measures.

- Containers for semiconductor materials should have anti-static protection or be made of conductive material.
- After mounting, printed circuit boards should be stored and shipped in conductive bags or containers.
- Work platforms, tools, and instruments should be properly grounded.
- Working personnel should be grounded with resistance of 250 kΩ to 1 MΩ between body and ground.

5. Do not apply negative voltages.

The use of negative voltages below -0.3 V may create parasitic transistors on LSI lines, which can cause abnormal operation

■ ORDERING INFORMATION

Part number	Package	Remarks
MB3874PFV MB3876PFV	24-pin plastic SSOP (FPT-24P-M03)	

PACKAGE DIMENSION

24-pin plastic SSOP
(FPT-24P-M03)

Note1 : Pins width and pins thickness include plating thickness.
Note2 : *This dimension does not include resin protrusion.

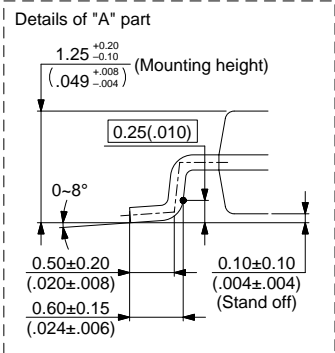
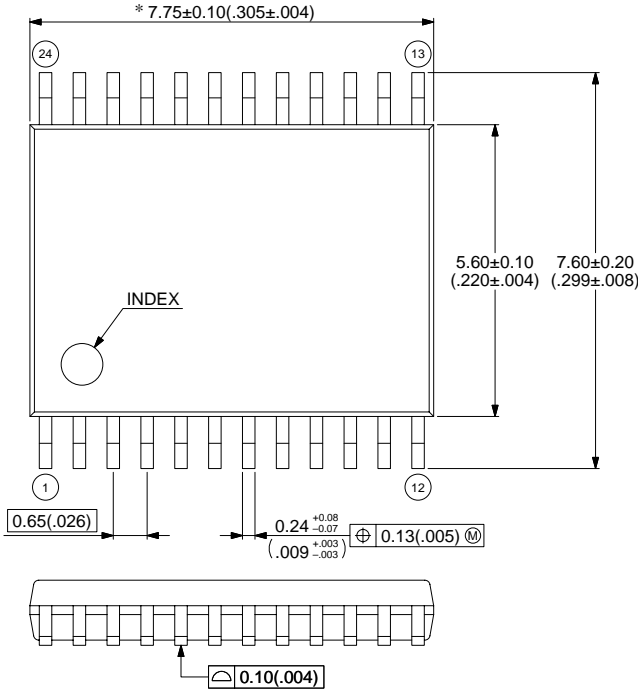

© 2001 FUJITSU LIMITED F24018S-c-3-4

Dimensions in mm (inches)

FUJITSU LIMITED

All Rights Reserved.

The contents of this document are subject to change without notice. Customers are advised to consult with FUJITSU sales representatives before ordering.

The information and circuit diagrams in this document are presented as examples of semiconductor device applications, and are not intended to be incorporated in devices for actual use. Also, FUJITSU is unable to assume responsibility for infringement of any patent rights or other rights of third parties arising from the use of this information or circuit diagrams.

The products described in this document are designed, developed and manufactured as contemplated for general use, including without limitation, ordinary industrial use, general office use, personal use, and household use, but are not designed, developed and manufactured as contemplated (1) for use accompanying fatal risks or dangers that, unless extremely high safety is secured, could have a serious effect to the public, and could lead directly to death, personal injury, severe physical damage or other loss (i.e., nuclear reaction control in nuclear facility, aircraft flight control, air traffic control, mass transport control, medical life support system, missile launch control in weapon system), or (2) for use requiring extremely high reliability (i.e., submersible repeater and artificial satellite).

Please note that Fujitsu will not be liable against you and/or any third party for any claims or damages arising in connection with above-mentioned uses of the products.

Any semiconductor devices have an inherent chance of failure. You must protect against injury, damage or loss from such failures by incorporating safety design measures into your facility and equipment such as redundancy, fire protection, and prevention of over-current levels and other abnormal operating conditions.

If any products described in this document represent goods or technologies subject to certain restrictions on export under the Foreign Exchange and Foreign Trade Law of Japan, the prior authorization by Japanese government will be required for export of those products from Japan.

F0209

© FUJITSU LIMITED Printed in Japan