

# *ASSP For Power Management Applications (General Purpose DC/DC Converter)*

## **2-ch DC/DC Converter IC with Overcurrent Protection**

# **MB39A104**

### ■ DESCRIPTION

The MB39A104 is a 2-channel DC/DC converter IC using pulse width modulation (PWM), incorporating an overcurrent protection circuit (requiring no current sense resistor). This IC is ideal for down conversion.

Operating at high frequency reduces the value of coil.

This is ideal for built-in power supply such as LCD monitors and ADSL.

This product is covered by US Patent Number 6,147,477.

### ■ FEATURES

- Built-in timer-latch overcurrent protection circuit (requiring no current sense resistor)
- Power supply voltage range : 7 V to 19 V
- Reference voltage : 5.0 V  $\pm$  1 %
- Error amplifier threshold voltage : 1.24 V  $\pm$  1 %
- High-frequency operation capability : 1.5 MHz (Max)
- Built-in standby function: 0  $\mu$ A (Typ)
- Built-in soft-start circuit independent of loads
- Built-in totem-pole type output for P-ch MOS FET
- One type of package (SSOP-24 pin : 1 type)

### ■ APPLICATION

- LCD monitor/panel
- IP phone
- Printer
- Video capture        etc.

# MB39A104

## ■ PIN ASSIGNMENTS

(TOP VIEW)

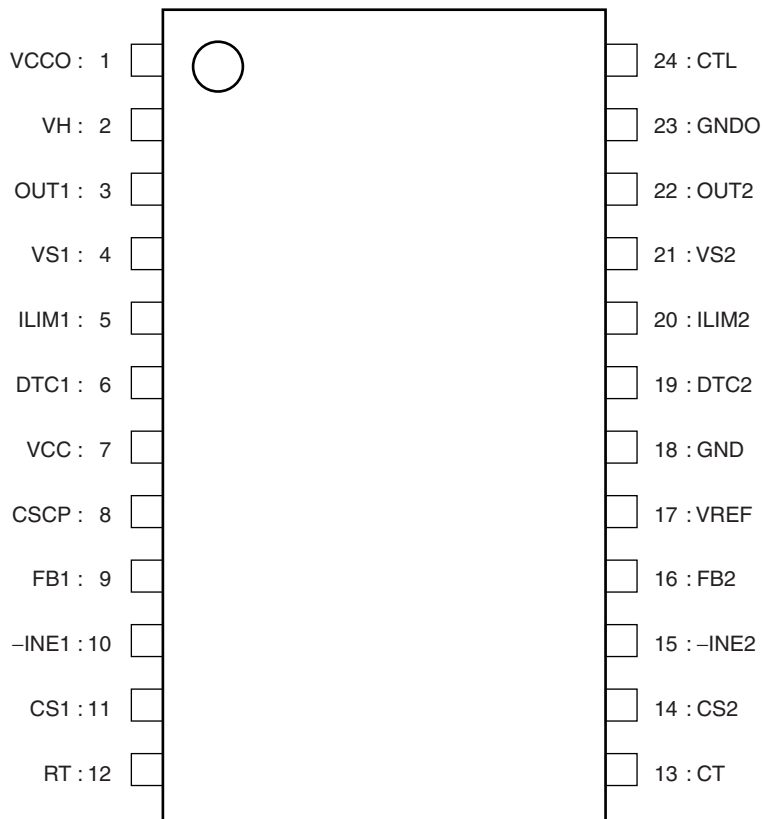

(FPT-24P-M03)

## ■ PIN DESCRIPTION

Pin No.	Symbol	I/O	Descriptions
1	VCCO	—	Output circuit power supply terminal (Connect to same potential as VCC pin)
2	VH	O	Power supply terminal for FET drive circuit ( $VH = V_{CC} - 5\text{ V}$ )
3	OUT1	O	External P-ch MOS FET gate drive terminal
4	VS1	I	Overcurrent protection circuit input terminal
5	ILIM1	I	Overcurrent protection circuit detection resistor connection terminal. Set overcurrent detection reference voltage depending on external resistor and internal current resource ( $110\ \mu\text{A}$ at $R_T = 24\ \text{k}\Omega$ )
6	DTC1	I	PWM comparator block (PWM) input terminal. Compares the lowest voltage among FB1 and DTC1 terminals with triangular wave and controls output.
7	VCC	—	Power supply terminal for reference power supply and control circuit (Connect to same potential as the VCCO terminal)
8	CSCP	—	Timer-latch short-circuit protection capacitor connection terminal
9	FB1	O	Error amplifier (Error Amp 1) output terminal
10	-INE1	I	Error amplifier (Error Amp 1) inverted input terminal
11	CS1	—	Soft-start capacitor connection terminal
12	RT	—	Triangular wave oscillation frequency setting resistor connection terminal
13	CT	—	Triangular wave oscillation frequency setting capacitor connection terminal
14	CS2	—	Soft-start capacitor connection terminal
15	-INE2	I	Error amplifier (Error Amp 2) inverted input terminal
16	FB2	O	Error amplifier (Error Amp 2) output terminal
17	VREF	O	Reference voltage output terminal
18	GND	—	Output circuit ground terminal (Connect to same potential as GNDO terminal.)
19	DTC2	I	PWM comparator block (PWM) input terminal. Compares the lowest voltage among FB2 and DTC2 terminals with triangular wave and controls output.
20	ILIM2	I	Overcurrent protection circuit detection resistor connection terminal. Set overcurrent detection reference voltage depending on external resistor and internal current resource ( $110\ \mu\text{A}$ at $R_T = 24\ \text{k}\Omega$ )
21	VS2	I	Overcurrent protection circuit input terminal
22	OUT2	O	External P-ch MOS FET gate drive terminal
23	GNDO	—	Output circuit ground terminal (Connect to same potential as GND terminal)
24	CTL	I	Power supply control terminal. Setting the CTL terminal at "L" level places IC in the standby mode.

# MB39A104

## ■ BLOCK DIAGRAM

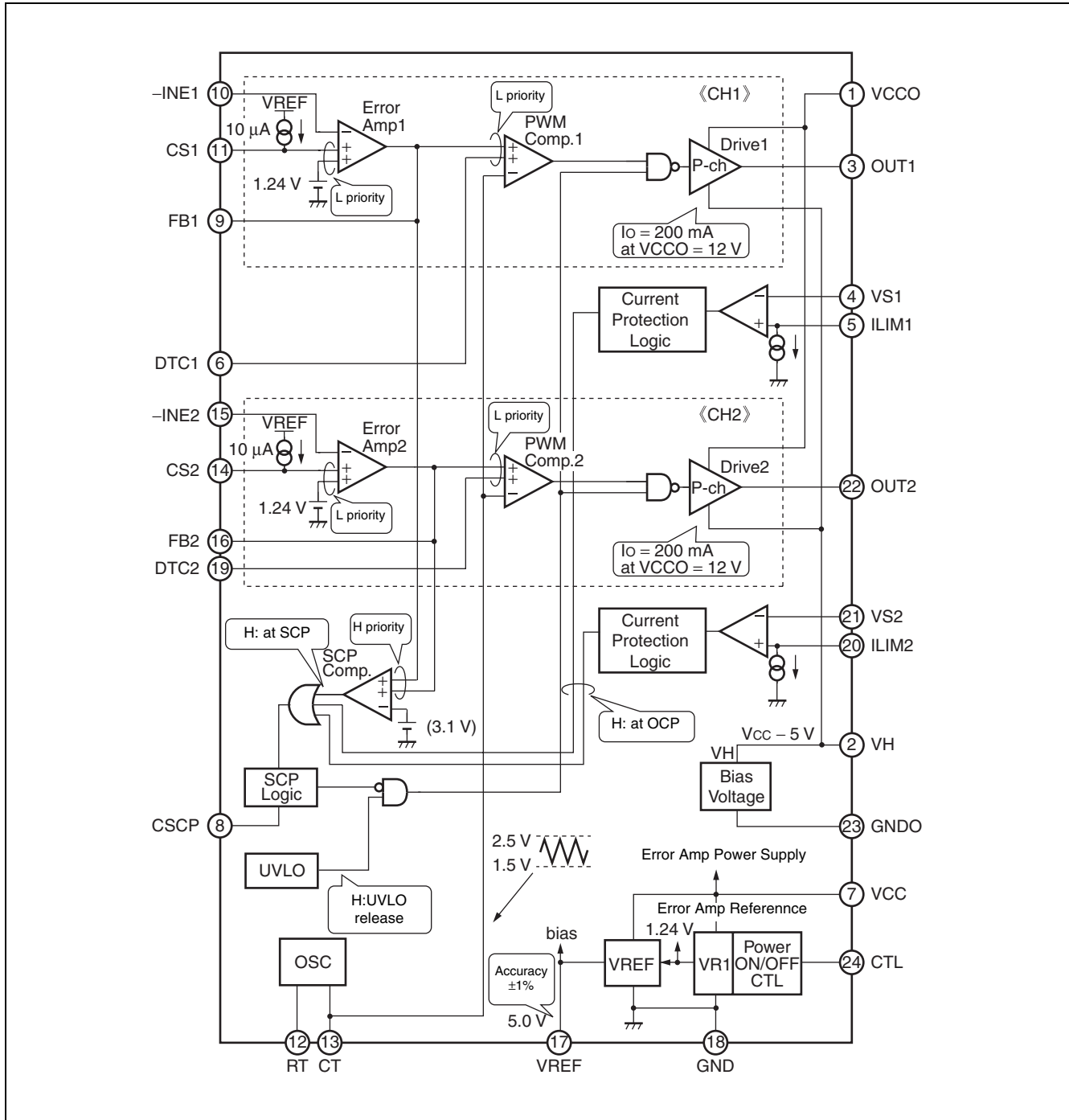

## ■ ABSOLUTE MAXIMUM RATINGS

Parameter	Symbol	Condition	Rating		Unit
			Min	Max	
Power supply voltage	V <sub>CC</sub>	VCC, VCCO terminal	—	20	V
Output current	I <sub>O</sub>	OUT1, OUT2 terminal	—	60	mA
Output peak current	I <sub>OP</sub>	Duty ≤ 5% (t = 1/f <sub>osc</sub> × Duty)	—	700	mA
Power dissipation	P <sub>D</sub>	T <sub>a</sub> ≤ +25 °C	—	740*	mW
Storage temperature	T <sub>STG</sub>	—	-55	+125	°C

\* : The packages are mounted on the epoxy board (10 cm × 10 cm).

WARNING: Semiconductor devices can be permanently damaged by application of stress (voltage, current, temperature, etc.) in excess of absolute maximum ratings. Do not exceed these ratings.

## ■ RECOMMENDED OPERATING CONDITIONS

Parameter	Symbol	Condition	Value			Unit
			Min	Typ	Max	
Power supply voltage	V <sub>CC</sub>	VCC, VCCO terminal	7	12	19	V
Reference voltage output current	I <sub>REF</sub>	VREF terminal	-1	—	0	mA
VH output current	I <sub>VH</sub>	VH terminal	0	—	30	mA
Input voltage	V <sub>INE</sub>	-INE1, -INE2 terminal	0	—	V <sub>CC</sub> - 0.9	V
	V <sub>DTC</sub>	DTC1, DTC2 terminal	0	—	V <sub>CC</sub> - 0.9	V
Control input voltage	V <sub>CTL</sub>	CTL terminal	0	—	19	V
Output current	I <sub>O</sub>	OUT1, OUT2 terminal	-45	—	+45	mA
Output Peak current	I <sub>OP</sub>	Duty ≤ 5% (t = 1/f <sub>osc</sub> × Duty)	-450	—	+450	mA
Oscillation frequency	f <sub>OSC</sub>	Overcurrent detection by ON resistance of FET	100	500	1000	kHz
		*	100	500	1500	kHz
Timing capacitor	C <sub>T</sub>	—	39	100	560	pF
Timing resistor	R <sub>T</sub>	—	11	24	130	kΩ
VH terminal capacitor	C <sub>VH</sub>	VH terminal	—	0.1	1.0	μF
Soft-start capacitor	C <sub>S</sub>	CS1, CS2 terminal	—	0.1	1.0	μF
Short-circuit detection capacitor	C <sub>SCP</sub>	CSCP terminal	—	0.1	1.0	μF
Reference voltage output capacitor	C <sub>REF</sub>	VREF terminal	—	0.1	1.0	μF
Operating ambient temperature	T <sub>a</sub>	—	-30	+25	+85	°C

\* : Refer to “ ■ SETTING THE TRIANGULAR OSCILLATION FREQUENCY”.

WARNING: The recommended operating conditions are required in order to ensure the normal operation of the semiconductor device. All of the device's electrical characteristics are warranted when the device is operated within these ranges.

Always use semiconductor devices within their recommended operating condition ranges. Operation outside these ranges may adversely affect reliability and could result in device failure.

No warranty is made with respect to uses, operating conditions, or combinations not represented on the data sheet. Users considering application outside the listed conditions are advised to contact their representatives beforehand.

# MB39A104

## ■ ELECTRICAL CHARACTERISTICS

(VCC = VCCO = 12 V, VREF = 0 mA, Ta = +25 °C)

Parameter	Symbol	Pin No	Conditions	Value			Unit	
				Min	Typ	Max		
1. Reference voltage block [REF]	Output voltage	V <sub>REF</sub>	17	Ta = +25 °C	4.95	5.00	5.05	V
	Output voltage temperature variation	$\frac{\Delta V_{REF}}{V_{REF}}$	17	Ta = 0 °C to +85 °C	—	0.5*	—	%
	Input stability	Line	17	VCC = 7 V to 19 V	—	3	10	mV
	Load stability	Load	17	VREF = 0 mA to -1 mA	—	1	10	mV
	Short-circuit output current	I <sub>OS</sub>	17	VREF = 1 V	-50	-25	-12	mA
2. Under voltage lockout protection circuit block [UVLO]	Threshold voltage	V <sub>TLH</sub>	17	VREF = $\frac{1}{2}$	2.6	2.8	3.0	V
		V <sub>THL</sub>	17	VREF = $\frac{2}{3}$	2.4	2.6	2.8	V
	Hysteresis width	V <sub>H</sub>	17	—	—	0.2*	—	V
3. Short-circuit detection block [SCP Logic]	Threshold voltage	V <sub>TH</sub>	8	—	0.68	0.73	0.78	V
	Input source current	I <sub>CS</sub>	8	—	-1.4	-1.0	-0.6	μA
	Reset voltage	V <sub>RST</sub>	17	VREF = $\frac{2}{3}$	2.4	2.6	2.8	V
4. Short-circuit detection block [SCP Comp.]	Threshold voltage	V <sub>TH</sub>	8	—	2.8	3.1	3.4	V
5. Triangular wave oscillator block [OSC]	Oscillation frequency	f <sub>OSC</sub>	13	C <sub>T</sub> = 100 pF, R <sub>T</sub> = 24 kΩ	450	500	550	kHz
	Frequency temperature variation	$\frac{\Delta f_{OSC}}{f_{OSC}}$	13	Ta = 0 °C to +85 °C	—	1*	—	%
6. Soft-start block [CS1, CS2]	Charge current	I <sub>CS</sub>	11, 14	CS1 = CS2 = 0 V	-14	-10	-6	μA
7. Error amplifier block [Error Amp1, Error Amp2]	Threshold voltage	V <sub>TH</sub>	9, 16	FB1 = FB2 = 2 V	1.227	1.240	1.253	V
	Input bias current	I <sub>B</sub>	10, 15	-INE1 = -INE2 = 0 V	-120	-30	—	nA
	Voltage gain	A <sub>V</sub>	9, 16	DC	—	100*	—	dB

(Continued)

(Continued)

(VCC = VCCO = 12 V, VREF = 0 mA, Ta = +25 °C)

Parameter		Symbol	Pin No.	Conditions	Value			Unit
					Min	Typ	Max	
7. Error amplifier block [Error Amp1, Error Amp2]	Frequency bandwidth	BW	9, 16	Av = 0 dB	—	1.6*	—	MHz
	Output voltage	VOH	9, 16	—	4.7	4.9	—	V
		VOL	9, 16	—	—	40	200	mV
	Output source current	ISOURCE	9, 16	FB1 = FB2 = 2 V	—	-2	-1	mA
Output sink current	ISINK	9, 16	FB1 = FB2 = 2 V	150	200	—	μA	
8. PWM comparator block [PWM Comp.1, PWM Comp.2]	Threshold voltage	VTO	6, 19	Duty cycle = 0 %	1.4	1.5	—	V
		VT100	6, 19	Duty cycle = Dtr	—	2.5	2.6	V
	Input current	IDTC	6, 19	DTC1 = DTC2 = 0.4 V	-2.0	-0.6	—	μA
9. Overcurrent protection circuit block [OCP1, OCP2]	ILIM terminal input current	ILIM	5, 20	Rr = 24 kΩ, Cr = 100 pF	99	110	121	μA
	Offset voltage	VO	5, 20	—	—	1*	—	mV
10. Bias voltage block [VH]	Output voltage	VH	2	VCC = VCCO = 7 V to 19 V VH = 0 mA to 30 mA	VCC-5.5	VCC-5.0	VCC-4.5	V
11. Output block [Drive1, Drive2]	Output source current	ISOURCE	3, 22	OUT1 to OUT4 = 7 V, Duty ≤ 5 % (t = 1/fosc×Duty)	—	-300	—	mA
	Output sink current	ISINK	3, 22	OUT1 to OUT4 = 12 V, Duty ≤ 5 % (t = 1/fosc×Duty)	—	350	—	mA
	Output ON resistor	ROH	3, 22	OUT1 = OUT2 = -45 mA	—	8.0	12.0	Ω
		ROL	3, 22	OUT1 = OUT2 = 45 mA	—	6.5	9.7	Ω
12. Control block [CTL]	CTL input voltage	VIH	24	IC Active mode	2	—	19	V
		VIL	24	IC Standby mode	0	—	0.8	V
	Input current	ICTLH	24	CTL = 5 V	—	50	100	μA
		ICTLL	24	CTL = 0 V	—	—	1	μA
13. General	Standby current	ICCS	1, 17	CTL = 0 V	—	0	10	μA
	Power supply current	ICC	1, 17	CTL = 5 V	—	4.0	6.0	mA

\*: Standard design value.

## TYPICAL CHARACTERISTICS

Power Supply Current vs. Power Supply Voltage

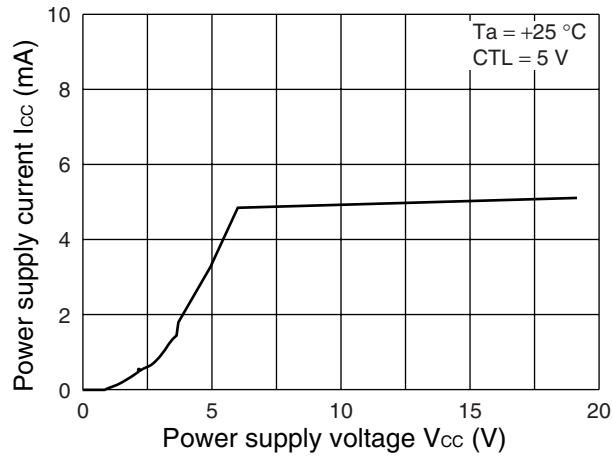

Reference Voltage vs. Power Supply Voltage

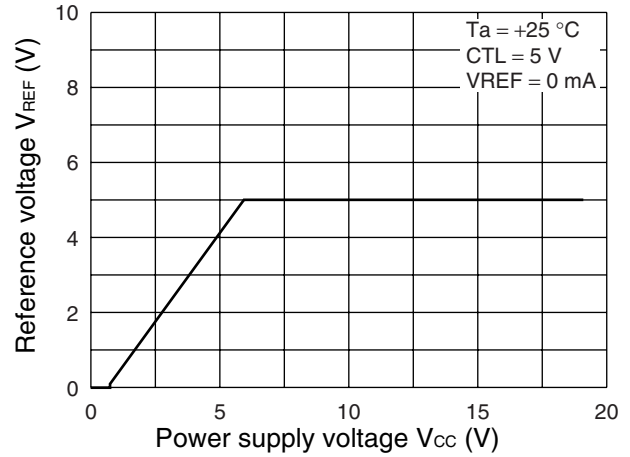

Reference Voltage vs. Load current

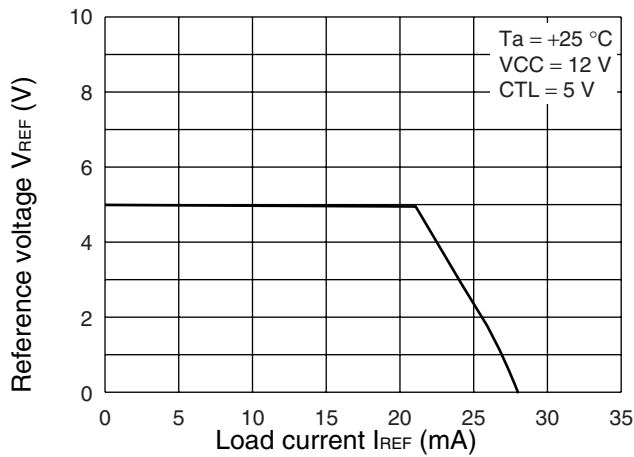

Reference Voltage vs. Ambient Temperature

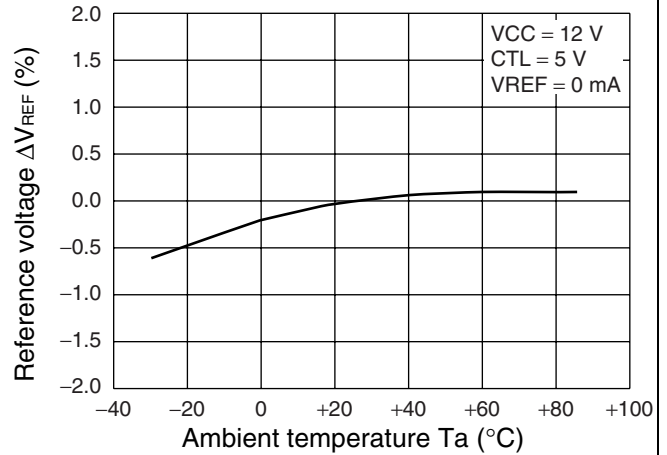

CTL terminal Current vs. CTL terminal Voltage

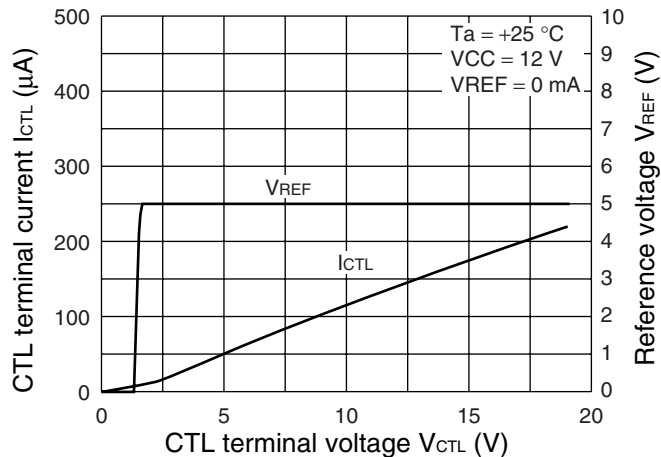

(Continued)

Triangular Wave Oscillation Frequency vs. Timing Resistor

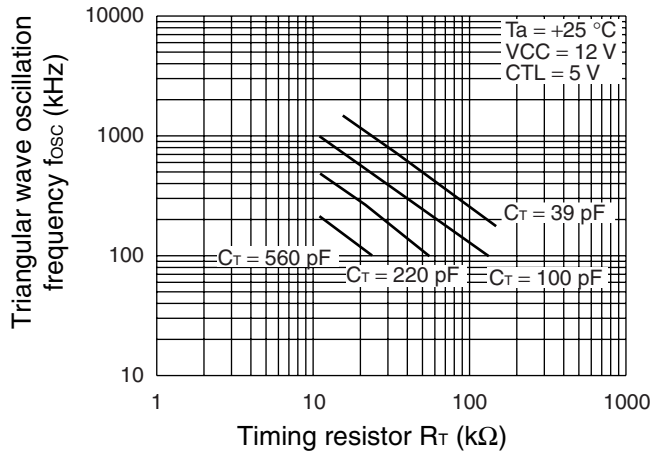

Triangular Wave Oscillation Frequency vs. Timing Capacitor

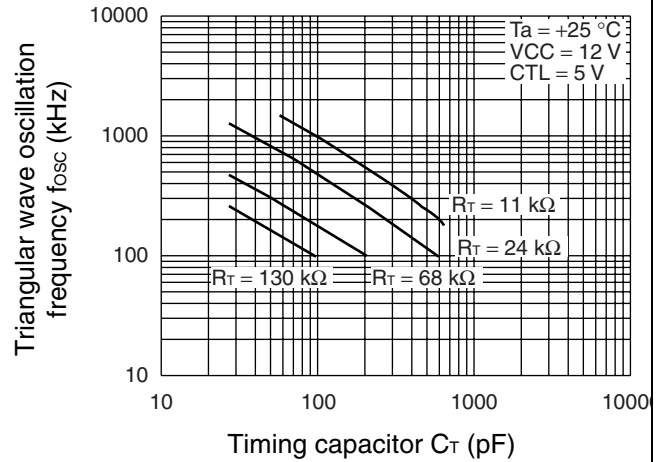

Triangular Wave Upper and Lower Limit Voltage vs. Triangular Wave Oscillation Frequency

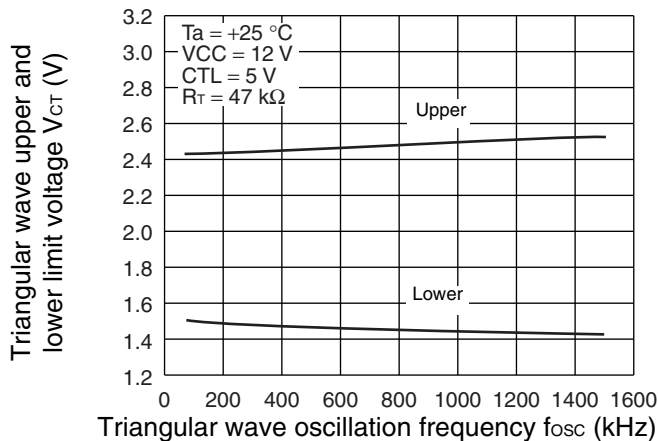

Triangular Wave Upper and Lower Limit Voltage vs. Ambient Temperature

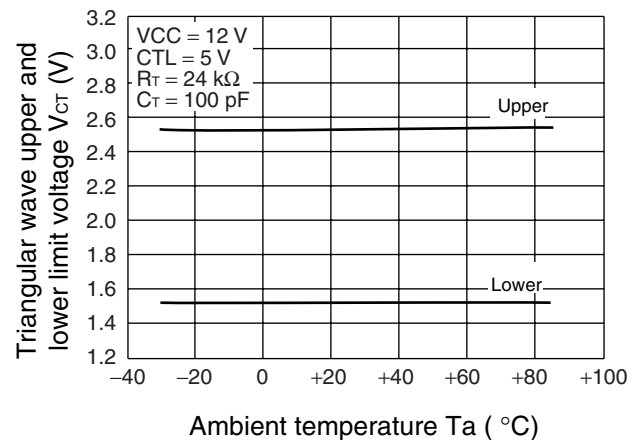

Triangular Wave Oscillation Frequency vs. Ambient Temperature

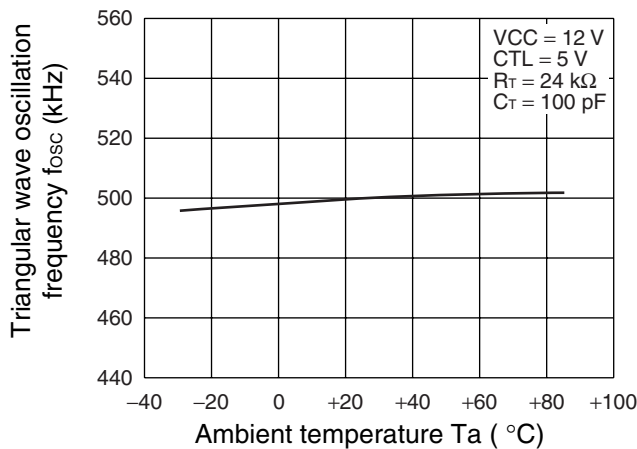

Triangular Wave Oscillation Frequency vs. Power supply voltage

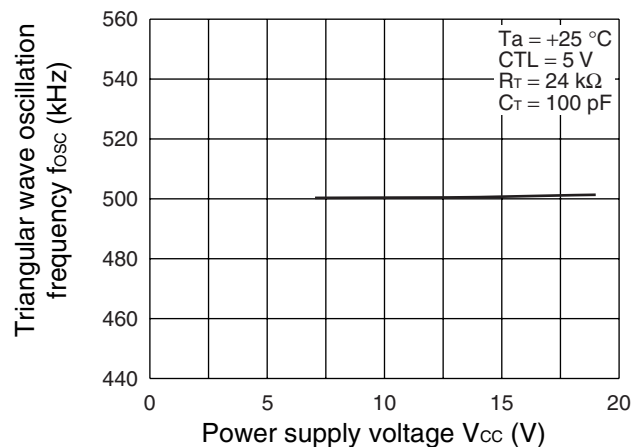

(Continued)

(Continued)

Error Amplifier, Gain, Phase vs. Frequency

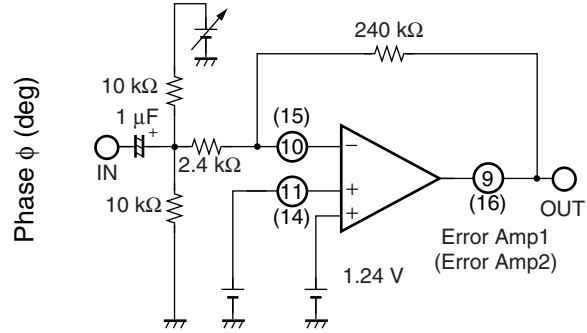
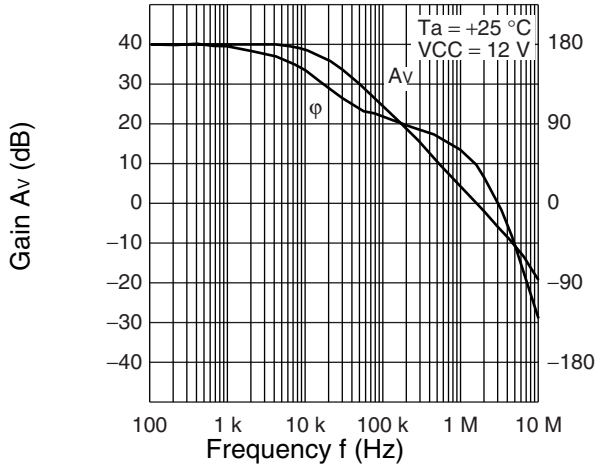

Power Dissipation vs. Ambient Temperature

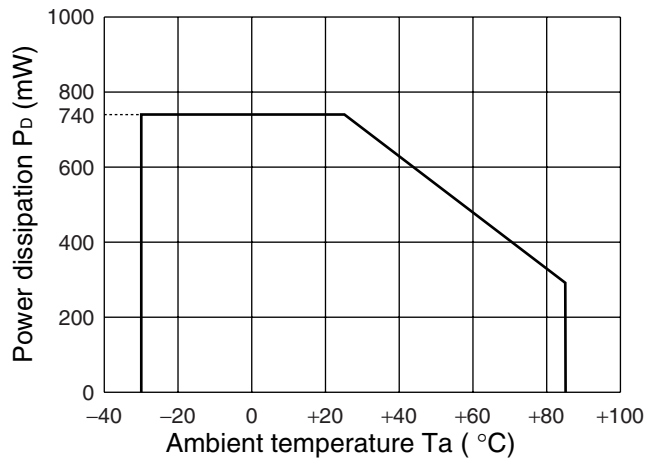

## ■ FUNCTIONS

### 1. DC/DC Converter Functions

#### (1) Reference voltage block (REF)

The reference voltage circuit generates a temperature-compensated reference voltage (5.0 V Typ) from the voltage supplied from the VCC terminal (pin 7). The voltage is used as the reference voltage for the IC's internal circuitry.

The reference voltage can supply a load current of up to 1 mA to an external device through the VREF terminal (pin 17).

#### (2) Triangular-wave oscillator block (OSC)

The triangular wave oscillator incorporates a timing capacitor and a timing resistor connected respectively to the CT terminal (pin 13) and RT terminal (pin 12) to generate triangular oscillation waveform amplitude of 1.5 V to 2.5 V.

The triangular waveforms are input to the PWM comparator in the IC.

#### (3) Error amplifier block (Error Amp1, Error Amp2)

The error amplifier detects the DC/DC converter output voltage and outputs PWM control signals. In addition, an arbitrary loop gain can be set by connecting a feedback resistor and capacitor from the output terminal to inverted input terminal of the error amplifier, enabling stable phase compensation to the system.

Also, it is possible to prevent rush current at power supply start-up by connecting a soft-start capacitor with the CS1 terminal (pin 11) and CS2 terminal (pin 14) which are the non-inverted input terminal for Error Amp. The use of Error Amp for soft-start detection makes it possible for a system to operate on a fixed soft-start time that is independent of the output load on the DC/DC converter.

#### (4) PWM comparator block (PWM Comp.1, PWM Comp.2)

The PWM comparator is a voltage-to-pulse width modulator that controls the output duty depending on the input/output voltage.

The comparator keeps output transistor on while the error amplifier output voltage remain higher than the triangular wave voltage.

#### (5) Output block (Drive1, Drive2)

The output block is in the totem pole configuration, capable of driving an external P-channel MOS FET.

#### (6) Bias voltage block (VH)

This bias voltage circuit outputs  $V_{CC} - 5$  V(Typ) as minimum potential of the output circuit. In standby mode, this circuit outputs the potential equal to  $V_{CC}$ .

## 2. Control Function

When CTL terminal (pin 24) is “L” level, IC becomes the standby mode. The power supply current is 10  $\mu$ A (Max) at the standby mode.

On/Off Setting Conditions

CTL	Power
L	OFF (Standby)
H	ON (Operating)

## 3. Protective Functions

### (1) Timer-latch overcurrent protection circuit block (OCP)

The timer-latch overcurrent protection circuit is actuated upon completion of the soft-start period. When an overcurrent flows, the circuit detects the increase in the voltage between the FET’s drain and source using the external FET ON resistor, actuates the timer circuit, and starts charging the capacitor  $C_{SCP}$  connected to the CSCP terminal (pin 8). If the overcurrent remains flowing beyond the predetermined period of time, latch is set and OUT terminals (pin 3,22) of each channel are fixed at “H” level. And the circuit sets the latch to turn off the external FET. The detection current value can be set by resistor  $R_{LIM1}$  connected between the FET’s drain and the ILIM1 terminal (pin 5) and resistor  $R_{LIM2}$  connected between the drain and the ILIM2 terminal (pin 20).

Changing connection enables to detect overcurrent at current sense resistor.

To reset the actuated protection circuit, either the power supply turn off and on again or set the CTL terminal (pin 6) to the “L” level to lower the VREF terminal (pin 17) voltage to 2.4 V (Min) or less. (Refer to “1. Setting Timer-Latch Overcurrent Protection Detection Current” in “■ABOUT TIMER-LATCH PROTECTION CIRCUIT”.)

### (2) Timer-latch short-circuit protection circuit (SCP Logic, SCP Comp.)

The short-circuit detection comparator (SCP Comp.) detects the output voltage level of Error Amp, and if the error amp output voltage of any channel falls below the short-circuit detection voltage (3.1 V Typ), the timer circuits are actuated to start charging the external capacitor  $C_{SCP}$  connected to the CSCP terminal (pin 8).

When the capacitor voltage reaches about 0.73 V, the circuit is turned off the output transistor and sets the dead time to 100 %.

To reset the actuated protection circuit, either the power supply turn off and on again or set the CTL terminal (pin 24) to the “L” level to lower the VREF terminal (pin 17) voltage to 2.4 V (Min) or less. (Refer to “2. Setting Time Constant for Timer-Latch Short-Circuit Protection Circuit” in “■ABOUT TIMER-LATCH PROTECTION CIRCUIT”.)

### (3) Under voltage lockout protection circuit (UVLO)

The transient state or a momentary decrease in supply voltage, which occurs when the power supply is turned on, may cause the IC to malfunction, resulting in breakdown or degradation of the system. To prevent such malfunctions, under voltage lockout protection circuit detects a decrease in internal reference voltage with respect to the power supply voltage, turns off the output transistor, and sets the dead time to 100% while holding the CSCP terminal (pin 8) at the “L” level.

The circuit restores the output transistor to normal when the supply voltage reaches the threshold voltage of the undervoltage lockout protection circuit.

### (4) Protection circuit operating function table

This table refers to output condition when protection circuit is operating.

Operating circuit	CS1	CS2	OUT1	OUT2
Overcurrent protection circuit	L	L	H	H
Short-circuit protection circuit	L	L	H	H
Under-voltage lockout	L	L	H	H

## ■ SETTING THE OUTPUT VOLTAGE

### • Output Voltage Setting Circuit

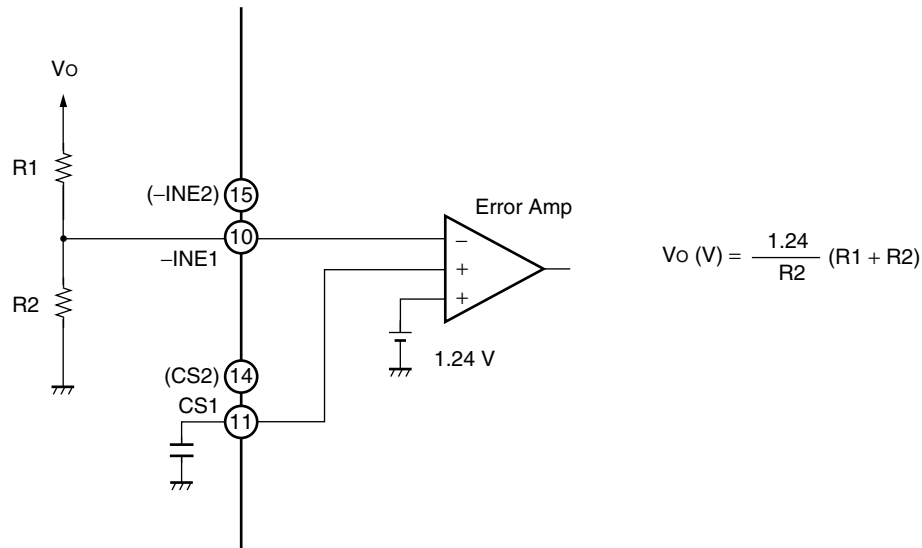

## ■ SETTING THE TRIANGULAR OSCILLATION FREQUENCY

The triangular oscillation frequency is determined by the timing capacitor ( $C_T$ ) connected to the CT terminal (pin 13), and the timing resistor ( $R_T$ ) connected to the RT terminal (pin 12).

Moreover, it shifts more greatly than the calculated values according to the constant of timing resistor ( $R_T$ ) when the triangular wave oscillation frequency exceeds 1 MHz. Therefore, set it referring to “Triangular Wave Oscillation Frequency vs. Timing Resistor” and “Triangular Wave Oscillation Frequency vs. Timing Capacitor” in “■ TYPICAL CHARACTERISTICS”.

Triangular oscillation frequency :  $f_{osc}$

$$f_{osc} \text{ (kHz)} \doteq \frac{1200000}{C_T \text{ (pF)} \times R_T \text{ (k}\Omega\text{)}}$$

## ■ SETTING THE SOFT-START AND DISCHARGE TIMES

To prevent rush currents when the IC is turned on, you can set a soft-start by connecting soft-start capacitors ( $C_{S1}$  and  $C_{S2}$ ) to the CS1 terminal (pin 11) for channel 1 and the CS2 terminal (pin 14) for channel 2, respectively. When CTL terminal (pin 24) goes to "H" level and IC starts ( $V_{CC} \geq UVLO$  threshold voltage), the external soft-start capacitors ( $C_{S1}$  and  $C_{S2}$ ) connected to CS1 and CS2 terminals are charged at  $10 \mu A$ . The error amplifier output (FB1 (pin 9) , FB2 (pin 16) ) is determined by comparison between the lower one of the potentials at two non-inverted input terminals (1.24 V, CS1 terminal voltages) and the inverted input terminal voltage ( $-INE1$  (pin 10) voltage,  $-INE2$  (pin 15) voltage).

The FB1 (FB2) terminal voltage is decided for the soft-start period by the comparison between 1.24 V in an internal reference voltage and the voltages of the CS1 (CS2) terminal. The DC/DC converter output voltage rises in proportion to the CS1 (CS2) terminal voltage as the soft-start capacitor connected to the CS1 (CS2) terminal is charged.

The soft-start time is obtained from the following formula:

Soft-start time:  $t_s$  (time to output 100%)

$$t_s (s) \approx 0.124 \times C_s (\mu F)$$

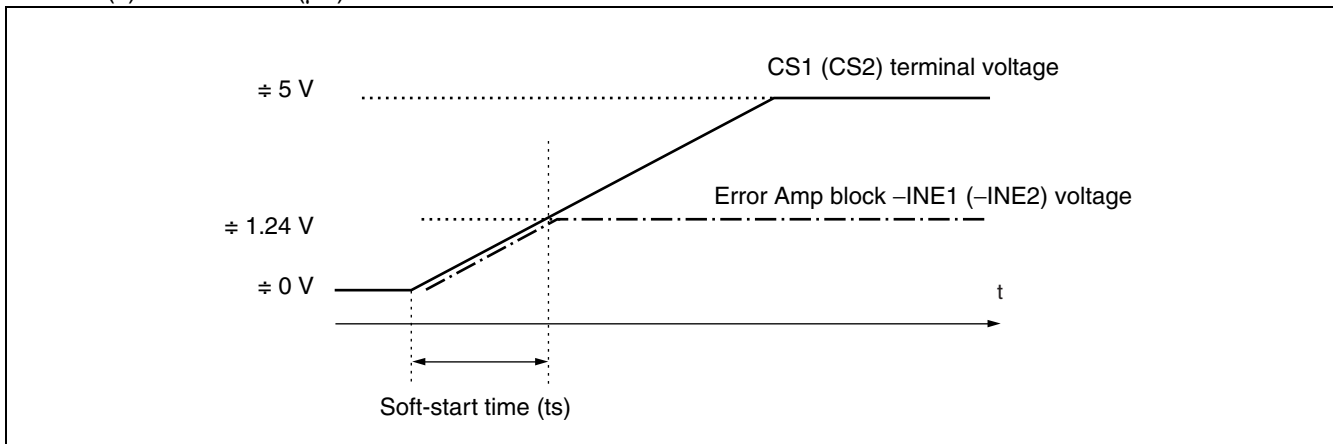

• Soft-Start Circuit

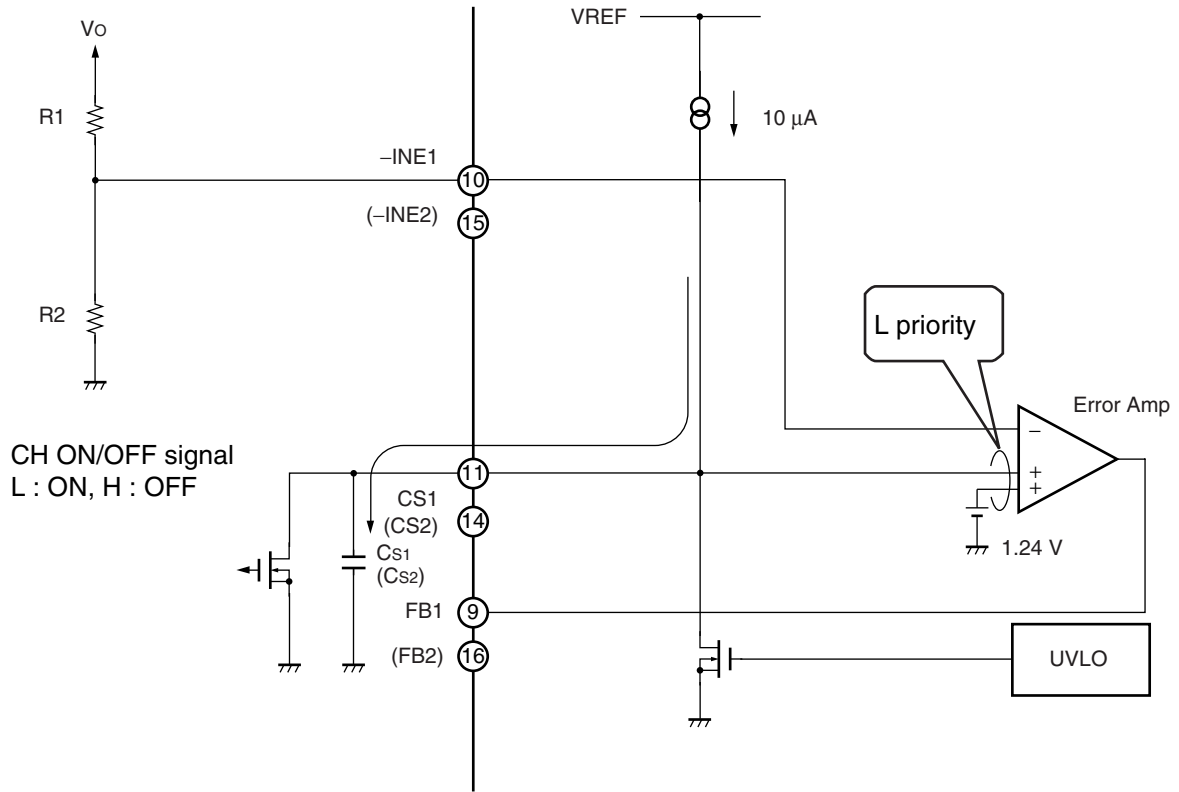

## ■ TREATMENT WITHOUT USING CS TERMINAL

When not using the soft-start function, open the CS1 terminal (pin 11) and the CS2 terminal (pin 14) .

- Without Setting Soft-Start Time

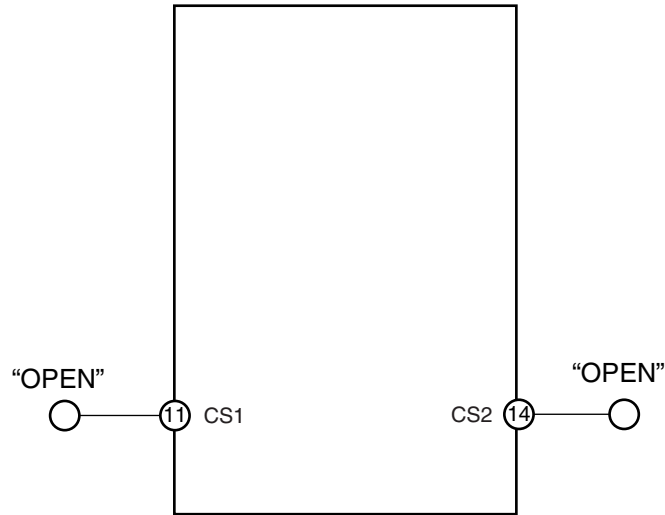

## ■ ABOUT TIMER-LATCH PROTECTION CIRCUIT

### 1. Setting Timer-Latch Overcurrent Protection Detection Current

The overcurrent protection circuit is actuated upon completion of the soft-start period. When an overcurrent flows, the circuit detects the increase in the voltage between the FET's drain and source using the external FET ON resistor ( $R_{ON}$ ), actuates the timer circuit, and starts charging the capacitor  $C_{SCP}$  connected to the CSCP terminal (pin 8). If the overcurrent remains flowing beyond the predetermined period of time, the circuit sets the latch to fix OUT terminals (pin 3, 22) at "H" level and turn off the external FET. The detection current value can be set by the resistors ( $R_{LIM1}$  and  $R_{LIM2}$ ) connected between the FET's drain and the ILIM1 terminal (pin 5) and between the drain and the ILIM2 terminal (pin 20), respectively.

The internal current ( $I_{LIM}$ ) can be set by the timing resistor ( $R_T$ ) connected to the RT terminal (pin 12).

Time until activating timer circuit and setting latch is equal to short-circuit detection time in "2. Setting Time Constant for Timer-Latch Short-Circuit Protection Circuit".

Internal current value:  $I_{LIM}$

$$I_{LIM} (\mu A) \cong \frac{2700}{R_T (k\Omega)}$$

Detection current value:  $I_{OCP}$

$$I_{OCP} (A) \cong \frac{I_{LIM}(A) \times R_{LIM}(\Omega)}{R_{ON} (\Omega)} - \frac{(V_{IN}(V) - V_O(V)) \times V_O(V)}{2 \times V_{IN}(V) \times f_{osc}(Hz) \times L(H)}$$

$R_{LIM}$  : Overcurrent detection resistor

$R_{ON}$  : External FET ON resistor

$V_{IN}$  : Input voltage

$V_O$  : DC/DC converter output voltage

$f_{osc}$  : Oscillation frequency

$L$  : Coil inductance

To reset the actuated protection circuit, either the power supply turn off and on again or set the CTL terminal (pin 24) to the "L" level to lower the VREF terminal (pin 17) voltage to 2.4 V (Min) or less.

#### • Overcurrent detection circuit

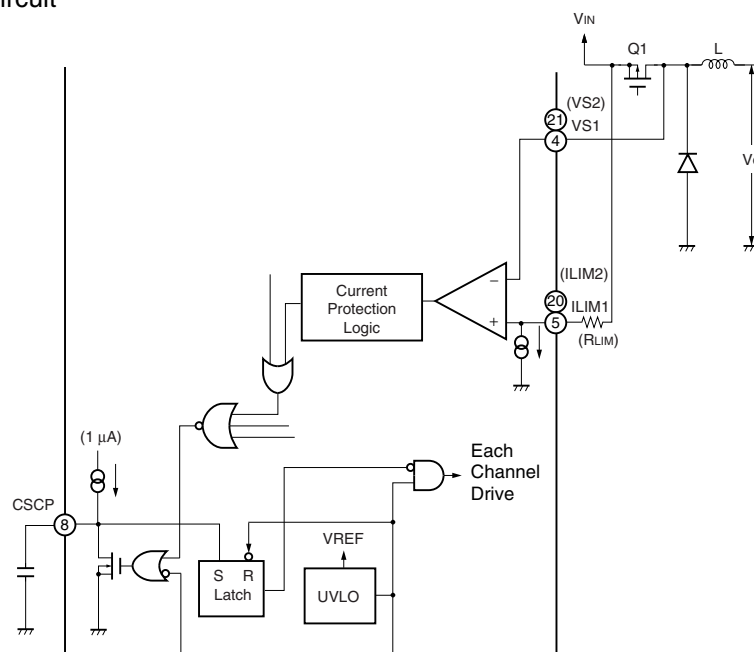

## Overcurrent Protection Circuit: Range of Operation

When an overcurrent flow occurs, if the increased voltage between the drain and source of the FET is detected by means of the external FET (Q1) resistor, operational stability is lost when the external FET (Q1) ON interval determined by the oscillation frequency, input voltage, and output voltage falls below 450 ns.

Therefore, the circuit should be used within a range that ensures that the ON interval does not fall below 450ns, according to the following formula.

$$\text{ON interval } 450 \text{ (ns)} \leq \frac{V_o \text{ (V)}}{V_{IN} \text{ (V)} \times f_{osc} \text{ (Hz)}}$$

If the ON interval of the external FET (Q1) is below 450ns, we recommend the use of an overcurrent detection resistor  $R_S$  to detect overcurrent, as shown below.

This example shows the range of operation of the overcurrent detection function with a setting of  $V_o = 3.3V$ .

- Method to detect by current when external FET(Q1) is turned on

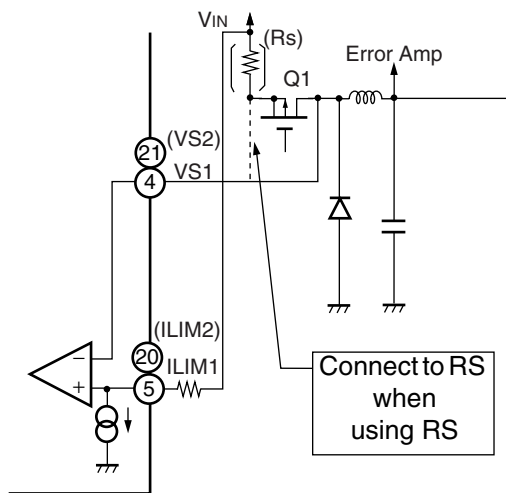

Overcurrent Detection Function Operating Range

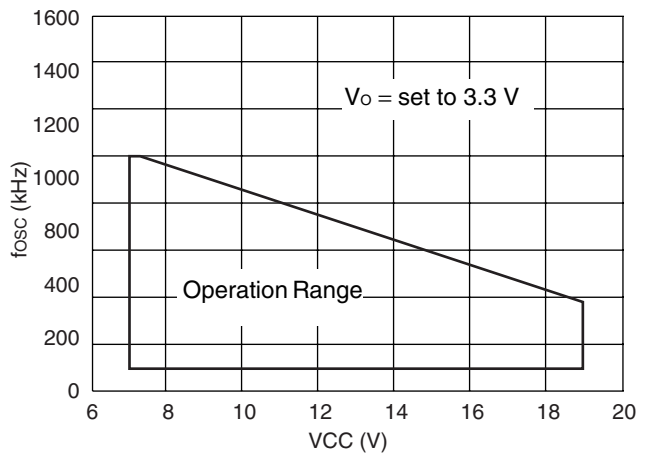

- Method to detect by mean current (Possible to detect at 2 V or more of output voltage)

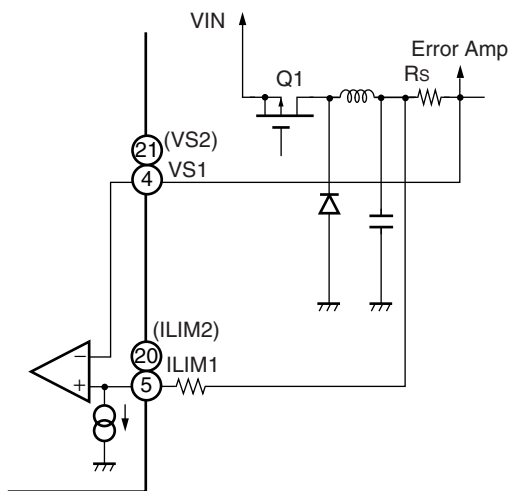

Overcurrent Detection Function Operating Range

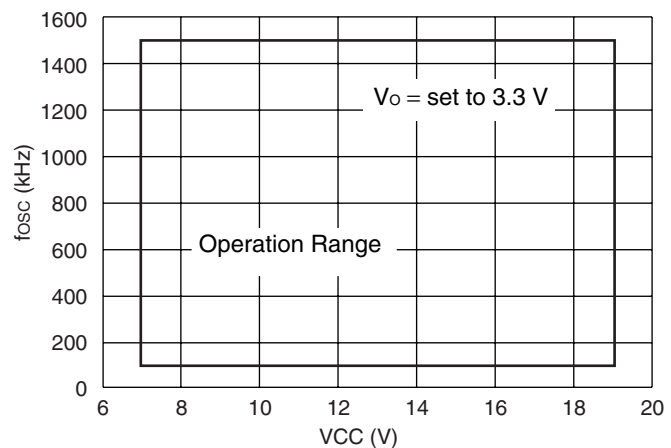

## 2. Setting Time Constant for Timer-Latch Short-Circuit Protection Circuit

Each channel uses the short-circuit detection comparator (SCP Comp.) to always compare the error amplifier's output level to the reference voltage (3.1 V Typ).

While DC/DC converter load conditions are stable on all channels, the short-circuit detection comparator output remains at "L" level, and the CSCP terminal (pin 8) is held at "L" level.

If the load condition on a channel changes rapidly due to a short-circuit of the load, causing the output voltage to drop, the output of the short-circuit detection comparator goes to "H" level. This causes the external short-circuit protection capacitor  $C_{SCP}$  connected to the CSCP terminal to be charged at  $1 \mu\text{A}$ .

Short-circuit detection time ( $t_{SCP}$ )

$$t_{SCP} \text{ (s)} \approx 0.73 \times C_{SCP} \text{ (\mu F)}$$

When the capacitor  $C_{SCP}$  is charged to the threshold voltage ( $V_{TH} \approx 0.73 \text{ V}$ ), the latch is set and the external FET is turned off (dead time is set to 100%). At this time, the latch input is closed and the CSCP terminal (pin 8) is held at "L" level. If a short-circuit is detected on either of the two channels, both channels are shut off.

When the power supply is turned on back or VREF terminal (pin 17) voltage is less than 2.4 V (Min) by setting CTL terminal (pin 24) to "L" level, the latch is released.

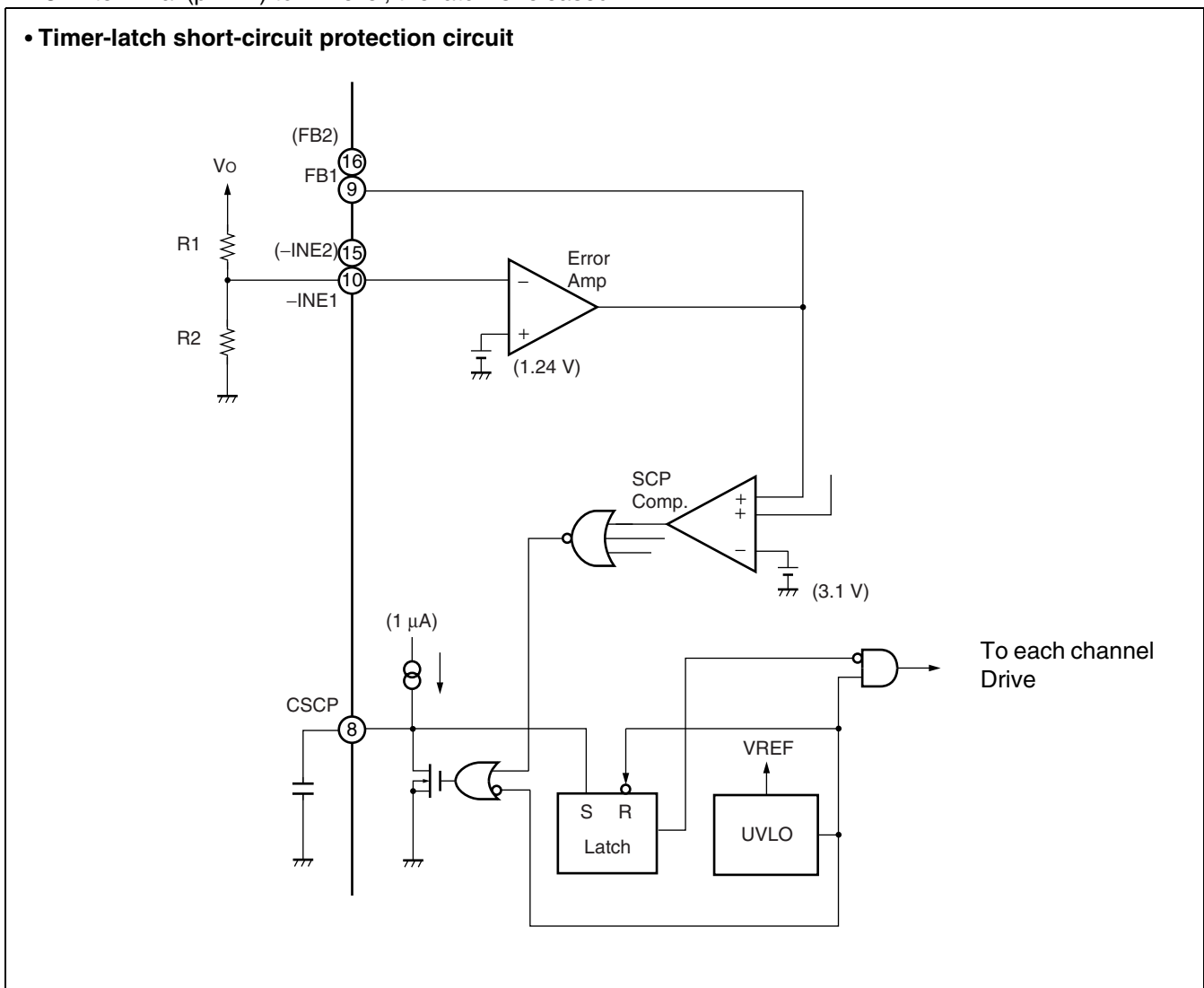

## ■ TREATMENT WITHOUT USING CSCP TERMINAL

When not using the timer-latch short-circuit protection circuit, connect the CSCP terminal (pin 8) to GND with the shortest distance.

### • Treatment without using CSCP

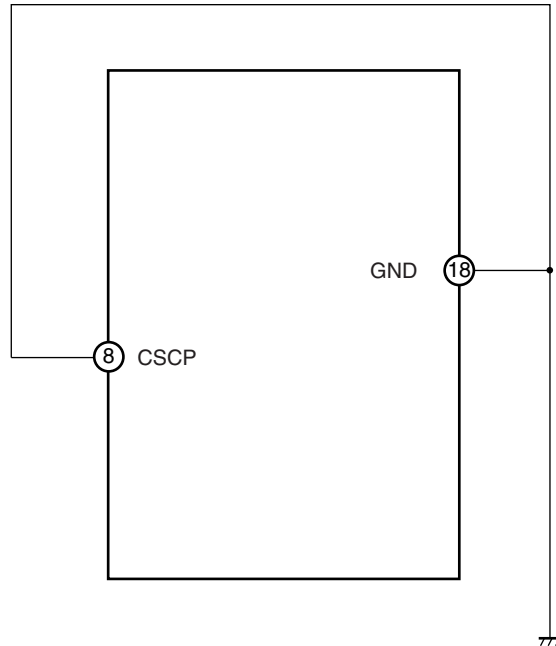

## ■ RESETTING THE LATCH OF EACH PROTECTION CIRCUIT

When the overcurrent, or short-circuit protection circuit detects each abnormality, it sets the latch to fix the output at the "L" level.

To reset the actuated protection circuit, either the power supply turn off and on again or set the CTL terminal (pin 24) to the "L" level to lower the VREF terminal (pin 17) voltage to 2.4 V (Min) or less.

## I/O EQUIVALENT CIRCUIT

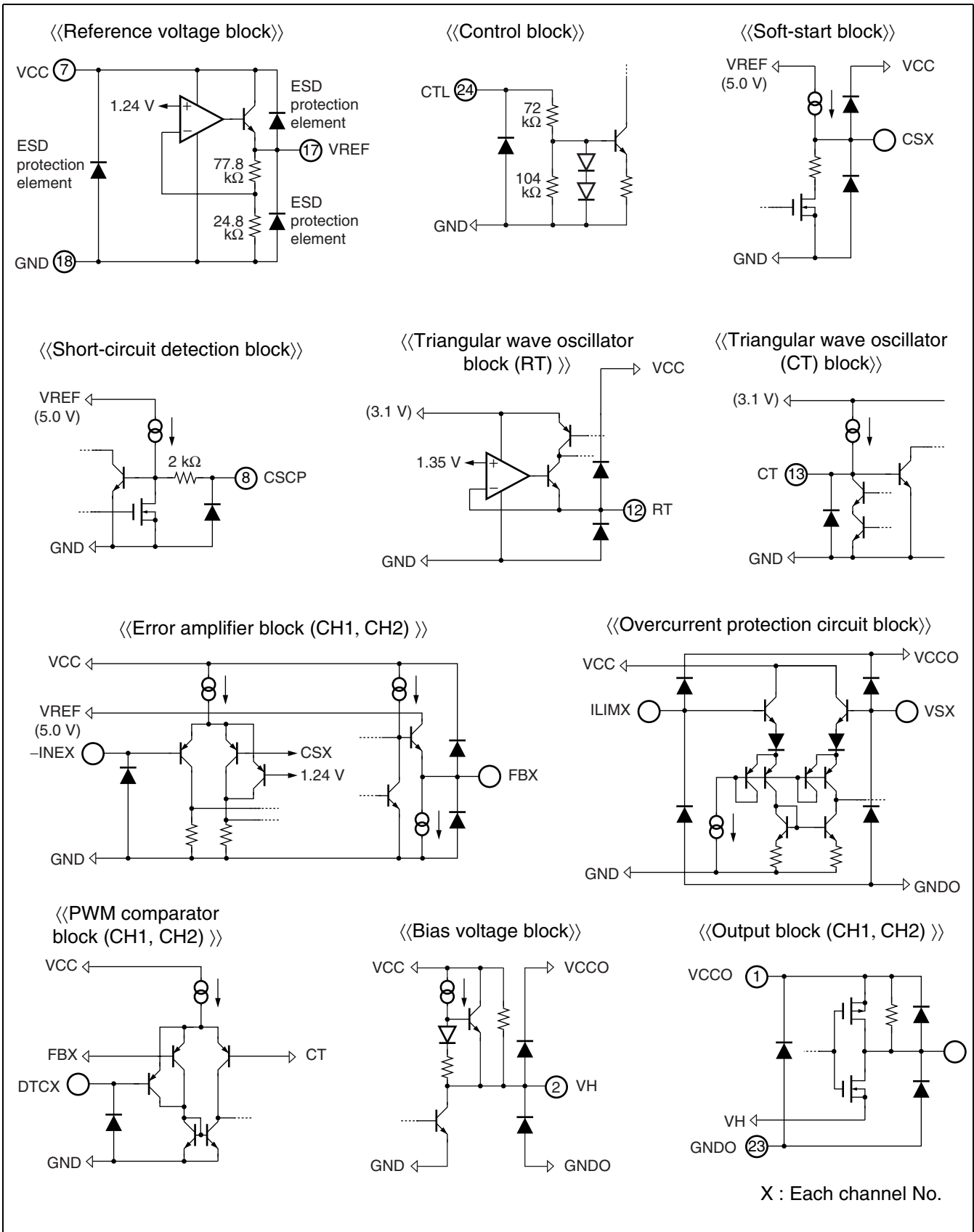

# MB39A104

## APPLICATION EXAMPLE

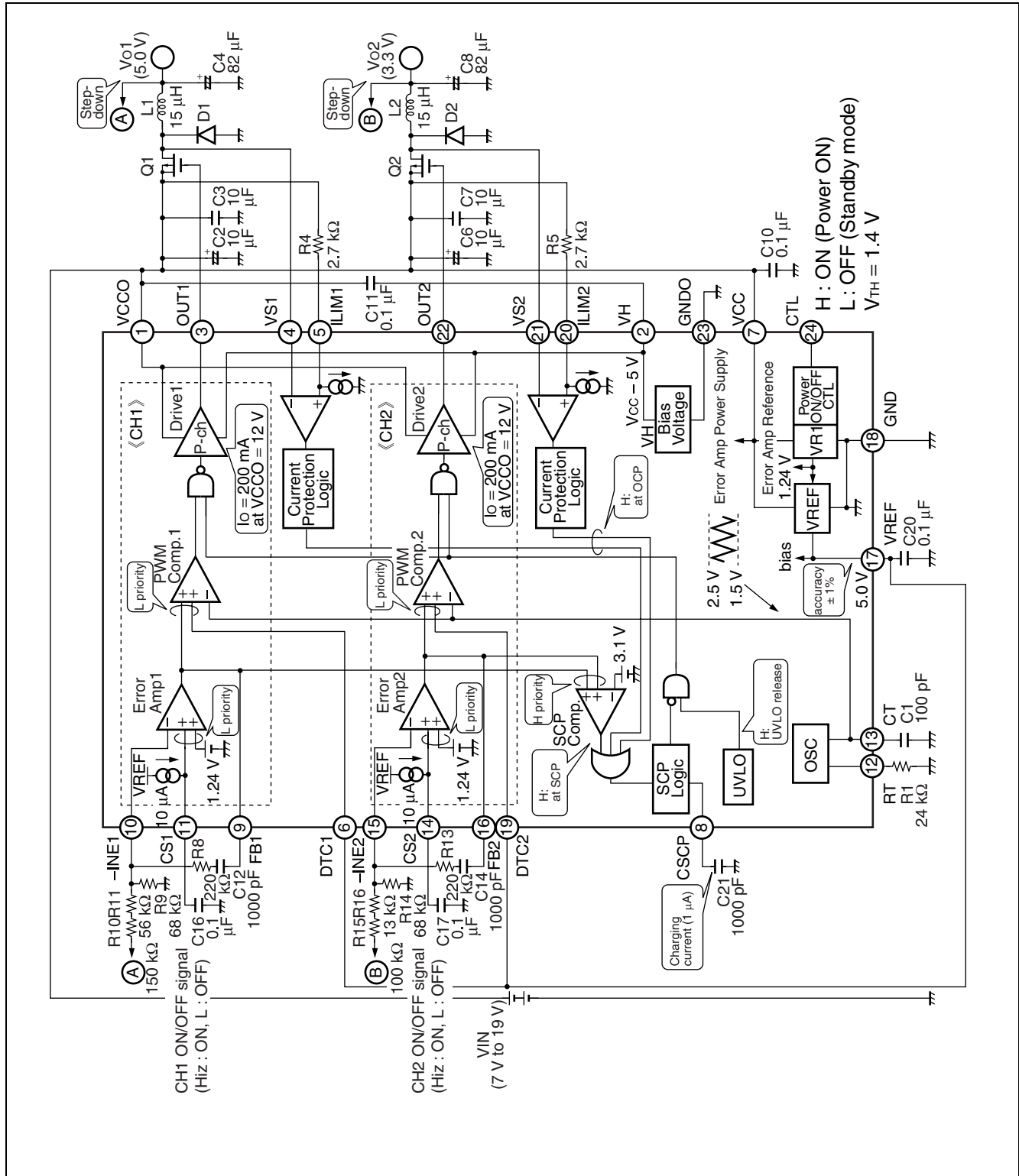

## ■ PARTS LIST

COMPONENT	ITEM	SPECIFICATION		VENDOR	PARTS No.
Q1, Q2	P-ch FET	VDS = -30 V, ID = -6 A		TOSHIBA	TPC8102
D1, D2	Diode	VF = 0.42 V (Max) , at IF = 3 A		ROHM	RB0530L-30
L1, L2	Inductor	15 $\mu$ H	3.6 A, 50 m $\Omega$	SUMIDA	CDRH104R-150
C1	Ceramics Condenser	100 pF	50 V	TDK	C1608CH1H101J
C2, C6	OS-CON™	10 $\mu$ F	20 V	SANYO	20SVP10M
C3, C7	Ceramics Condenser	10 $\mu$ F	25 V	TDK	C3225JF1E106Z
C4, C8	OS-CON™	82 $\mu$ F	6.3 V	SANYO	6SVP82M
C10, C11, C20	Ceramics Condenser	0.1 $\mu$ F	50 V	TDK	C1608JB1H104K
C12, C14, C21	Ceramics Condenser	1000 pF	50 V	TDK	C1608JB1H102K
C16, C17	Ceramics Condenser	0.1 $\mu$ F	50 V	TDK	C1608JB1H104K
R1	Resistor	24 k $\Omega$	0.5 %	ssm	RR0816P-243-D
R4, R5	Resistor	2.7 k $\Omega$	0.5 %	ssm	RR0816P-272-D
R8, R13	Resistor	220 k $\Omega$	0.5 %	ssm	RR0816P-224-D
R9, R14	Resistor	68 k $\Omega$	0.5 %	ssm	RR0816P-683-D
R10	Resistor	150 k $\Omega$	0.5 %	ssm	RR0816P-154-D
R11	Resistor	56 k $\Omega$	0.5 %	ssm	RR0816P-563-D
R15	Resistor	100 k $\Omega$	0.5 %	ssm	RR0816P-104-D
R16	Resistor	13 k $\Omega$	0.5 %	ssm	RR0816P-133-D

Note : TOSHIBA : TOSHIBA Corporation  
 ROHM : ROHM Co., Ltd  
 SANYO : SANYO Electric Co., Ltd.  
 TDK : TDK Corporation  
 SUMIDA : SUMIDA Electric Co., Ltd.  
 ssm : SUSUMU Co., Ltd.

## ■ SELECTION OF COMPONENTS

### • P-ch MOS FET

The P-ch MOSFET for switching use should be rated for at least 20% more than the maximum input voltage. To minimize continuity loss, use a FET with low  $R_{DS(ON)}$  between the drain and source. For high input voltage and high frequency operation, on/off-cycle switching loss will be higher so that power dissipation must be considered. In this application, the Toshiba TPC8102 is used. Continuity loss, on/off switching loss, and total loss are determined by the following formulas. The selection must ensure that peak drain current does not exceed rated values, and also must be in accordance with overcurrent detection levels.

Continuity loss :  $P_C$

$$P_C = I_D^2 \times R_{DS(ON)} \times \text{Duty}$$

On-cycle switching loss :  $P_S(ON)$

$$P_S(ON) = \frac{V_D(\text{Max}) \times I_D \times t_r \times f_{OSC}}{6}$$

Off-cycle switching loss :  $P_S(OFF)$

$$P_S(OFF) = \frac{V_D(\text{Max}) \times I_D(\text{Max}) \times t_f \times f_{OSC}}{6}$$

Total loss :  $P_T$

$$P_T = P_C + P_S(ON) + P_S(OFF)$$

Example: Using the Toshiba TPC8102

CH1

Input voltage  $V_{IN(\text{Max})} = 19 \text{ V}$ , output voltage  $V_O = 5 \text{ V}$ , drain current  $I_D = 3 \text{ A}$ , Oscillation frequency  $f_{OSC} = 500 \text{ kHz}$ ,  $L = 15 \text{ } \mu\text{H}$ , drain-source on resistance  $R_{DS(ON)} \cong 50 \text{ m}\Omega$ ,  $t_r = t_f \cong 100 \text{ ns}$ .

Drain current (Max) :  $I_D(\text{Max})$

$$\begin{aligned} I_{D(\text{Max})} &= I_O + \frac{V_{IN} - V_O}{2L} t_{on} \\ &= 3 + \frac{19 - 5}{2 \times 15 \times 10^{-6}} \times \frac{1}{500 \times 10^3} \times 0.263 \\ &\cong \underline{3.25 \text{ (A)}} \end{aligned}$$

Drain current (Min) :  $I_D(\text{Min})$

$$\begin{aligned} I_{D(\text{Min})} &= I_O - \frac{V_{IN} - V_O}{2L} t_{on} \\ &= 3 - \frac{19 - 5}{2 \times 15 \times 10^{-6}} \times \frac{1}{500 \times 10^3} \times 0.263 \\ &\cong \underline{2.75 \text{ (A)}} \end{aligned}$$

$$\begin{aligned}
 P_C &= I_D^2 \times R_{DS(ON)} \times \text{Duty} \\
 &= 3^2 \times 0.05 \times 0.263 \\
 &\doteq \underline{0.118 \text{ W}}
 \end{aligned}$$

$$\begin{aligned}
 P_{S(ON)} &= \frac{V_D(\text{Max}) \times I_D \times t_r \times f_{OSC}}{6} \\
 &= \frac{19 \times 3 \times 100 \times 10^{-9} \times 500 \times 10^3}{6} \\
 &\doteq \underline{0.475 \text{ W}}
 \end{aligned}$$

$$\begin{aligned}
 P_{S(OFF)} &= \frac{V_D(\text{Max}) \times I_D(\text{Max}) \times t_f \times f_{OSC}}{6} \\
 &= \frac{19 \times 3.25 \times 100 \times 10^{-9} \times 500 \times 10^3}{6} \\
 &\doteq \underline{0.515 \text{ W}}
 \end{aligned}$$

$$\begin{aligned}
 P_T &= P_C + P_{S(ON)} + P_{S(OFF)} \\
 &\doteq 0.118 + 0.475 + 0.515 \\
 &\doteq \underline{1.108 \text{ W}}
 \end{aligned}$$

The above power dissipation figures for the TPC8102 are satisfied with ample margin at 2.4 W ( $T_a = +25^\circ\text{C}$ ).

## CH2

Input voltage  $V_{IN(\text{Max})} = 19 \text{ V}$  output voltage  $V_O = 3.3 \text{ V}$ , drain current  $I_D = 3 \text{ A}$ , Oscillation frequency  $f_{OSC} = 500 \text{ kHz}$ ,  $L = 15 \mu\text{H}$ , drain-source on resistance  $R_{DS(ON)} \doteq 50 \text{ m}\Omega$ ,  $t_r = t_f \doteq 100 \text{ ns}$ .

Drain current (Max) :  $I_D(\text{Max})$

$$\begin{aligned}
 I_{D(\text{Max})} &= I_o + \frac{V_{IN} - V_O}{2L} t_{on} \\
 &= 3 + \frac{19 - 3.3}{2 \times 15 \times 10^{-6}} \times \frac{1}{500 \times 10^3} \times 0.174 \\
 &\doteq \underline{3.18 \text{ (A)}}
 \end{aligned}$$

Drain current (Min) :  $I_D(\text{Min})$

$$\begin{aligned}
 I_{D(\text{Min})} &= I_o - \frac{V_{IN} - V_O}{2L} t_{on} \\
 &= 3 - \frac{19 - 3.3}{2 \times 15 \times 10^{-6}} \times \frac{1}{500 \times 10^3} \times 0.174 \\
 &\doteq \underline{2.82 \text{ (A)}}
 \end{aligned}$$

# MB39A104

$$\begin{aligned} P_C &= I_D^2 \times R_{DS(ON)} \times \text{Duty} \\ &= 3^2 \times 0.05 \times 0.174 \\ &\doteq \underline{0.078 \text{ W}} \end{aligned}$$

$$\begin{aligned} P_{S(ON)} &= \frac{V_D(\text{Max}) \times I_D \times t_r \times f_{OSC}}{6} \\ &= \frac{19 \times 3 \times 100 \times 10^{-9} \times 500 \times 10^3}{6} \\ &\doteq \underline{0.475 \text{ W}} \end{aligned}$$

$$\begin{aligned} P_{S(OFF)} &= \frac{V_D(\text{Max}) \times I_D(\text{Max}) \times t_f \times f_{OSC}}{6} \\ &= \frac{19 \times 3.18 \times 100 \times 10^{-9} \times 500 \times 10^3}{6} \\ &\doteq \underline{0.504 \text{ W}} \end{aligned}$$

$$\begin{aligned} P_T &= P_C + P_{S(ON)} + P_{S(OFF)} \\ &\doteq 0.078 + 0.475 + 0.504 \\ &\doteq \underline{1.057 \text{ W}} \end{aligned}$$

The above power dissipation figures for the TPC8102 are satisfied with ample margin at 2.4 W ( $T_a = +25^\circ\text{C}$ ).

## • Inductors

In selecting inductors, it is of course essential not to apply more current than the rated capacity of the inductor, but also to note that the lower limit for ripple current is a critical point that if reached will cause discontinuous operation and a considerable drop in efficiency. This can be prevented by choosing a higher inductance value, which will enable continuous operation under light loads. Note that if the inductance value is too high, however, direct current resistance (DCR) is increased and this will also reduce efficiency. The inductance must be set at the point where efficiency is greatest.

Note also that the DC superimposition characteristics become worse as the load current value approaches the rated current value of the inductor, so that the inductance value is reduced and ripple current increases, causing loss of efficiency. The selection of rated current value and inductance value will vary depending on where the point of peak efficiency lies with respect to load current.

Inductance values are determined by the following formulas.

The L value for all load current conditions is set so that the peak to peak value of the ripple current is 1/2 the load current or less.

$$\begin{aligned} &\text{Inductance value : L} \\ L &\geq \frac{2(V_{IN} - V_O)}{I_o} \text{ ton} \end{aligned}$$

Example:

CH1

$$L \geq \frac{2(V_{IN} - V_o)}{I_o} \text{ton}$$

$$\geq \frac{2 \times (19 - 5)}{I_o} \times \frac{1}{500 \times 10^3} \times 0.263$$

$$\geq \underline{4.91 \mu\text{H}}$$

CH2

$$L \geq \frac{2(V_{IN} - V_o)}{I_o} \text{ton}$$

$$\geq \frac{2 \times (19 - 3.3)}{I_o} \times \frac{1}{500 \times 10^3} \times 0.174$$

$$\geq \underline{3.64 \mu\text{H}}$$

Inductance values derived from the above formulas are values that provide sufficient margin for continuous operation at maximum load current, but at which continuous operation is not possible at light loads. It is therefore necessary to determine the load level at which continuous operation becomes possible. In this application, the Sumida CDRH104R-150 is used. At 15  $\mu\text{H}$ , the load current value under continuous operating conditions is determined by the following formula.

Load current value under continuous operating conditions :  $I_o$

$$I_o \geq \frac{V_o}{2L} \text{toff}$$

Example: Using the CDRH104R-150

15  $\mu\text{H}$  (allowable tolerance  $\pm 30\%$ ) , rated current = 3.6 A

CH1

$$I_o \geq \frac{V_o}{2L} \text{toff}$$

$$\geq \frac{5}{2 \times 15 \times 10^{-6}} \times \frac{1}{500 \times 10^3} \times (1 - 0.263)$$

$$\geq \underline{245.7 \text{ mA}}$$

CH2

$$I_o \geq \frac{V_o}{2L} \text{toff}$$

$$\geq \frac{3.3}{2 \times 15 \times 10^{-6}} \times \frac{1}{500 \times 10^3} \times (1 - 0.174)$$

$$\geq \underline{181.7 \text{ mA}}$$

# MB39A104

To determine whether the current through the inductor is within rated values, it is necessary to determine the peak value of the ripple current as well as the peak-to-peak values of the ripple current that affect the output ripple voltage. The peak value and peak-to-peak value of the ripple current can be determined by the following formulas.

Peak value :  $I_L$

$$I_L \geq I_o + \frac{V_{IN} - V_o}{2L} \text{ton}$$

Peak-to-peak value :  $\Delta I_L$

$$\Delta I_L = \frac{V_{IN} - V_o}{L} \text{ton}$$

Example: Using the CDRH104R-150

15  $\mu\text{H}$  (allowable tolerance  $\pm 30\%$ ) , rated current = 3.6 A

Peak value:

CH1

$$\begin{aligned} I_L &\geq I_o + \frac{V_{IN} - V_o}{2L} \text{ton} \\ &\geq 3 + \frac{19 - 5}{2 \times 15 \times 10^{-6}} \times \frac{1}{500 \times 10^3} \times 0.263 \\ &\geq \underline{3.25 \text{ A}} \end{aligned}$$

CH2

$$\begin{aligned} I_L &\geq I_o + \frac{V_{IN} - V_o}{2L} \text{ton} \\ &\geq 3 + \frac{19 - 3.3}{2 \times 15 \times 10^{-6}} \times \frac{1}{500 \times 10^3} \times 0.174 \\ &\geq \underline{3.18 \text{ A}} \end{aligned}$$

Peak-to-peak value:

CH1

$$\begin{aligned} \Delta I_L &= \frac{V_{IN} - V_o}{L} \text{ton} \\ &= \frac{19 - 5}{15 \times 10^{-6}} \times \frac{1}{500 \times 10^3} \times 0.263 \\ &= \underline{0.491 \text{ A}} \end{aligned}$$

CH2

$$\begin{aligned} \Delta I_L &= \frac{V_{IN} - V_o}{L} \text{ton} \\ &= \frac{19 - 3.3}{15 \times 10^{-6}} \times \frac{1}{500 \times 10^3} \times 0.174 \\ &= \underline{0.364 \text{ A}} \end{aligned}$$

## • Flyback diode

The flyback diode is generally used as a Schottky barrier diode (SBD) when the reverse voltage to the diode is less than 40V. The SBD has the characteristics of higher speed in terms of faster reverse recovery time, and lower forward voltage, and is ideal for achieving high efficiency. As long as the DC reverse voltage is sufficiently higher than the input voltage, the average current flowing through the diode is within the average output current level, and peak current is within peak surge current limits, there is no problem. In this application the Rohm RB053L-30 is used. The diode average current and diode peak current can be calculated by the following formulas.

Diode mean current :  $I_{Di}$

$$I_{Di} \geq I_o \times \left(1 - \frac{V_o}{V_{IN}}\right)$$

Diode peak current :  $I_{Dip}$

$$I_{Dip} \geq \left(I_o + \frac{V_o}{2L} \text{toff}\right)$$

Example: Using the Rohm RB053L-30

VR (DC reverse voltage) = 30 V, average output voltage = 3.0 A, peak surge current = 70 A,

VF (forward voltage) = 0.42 V, IF = 3.0 A

CH1

$$I_{Di} \geq I_o \times \left(1 - \frac{V_o}{V_{IN}}\right)$$

$$\geq 3 \times (1 - 0.263)$$

$$\geq \underline{2.21 \text{ A}}$$

CH2

$$I_{Di} \geq I_o \times \left(1 - \frac{V_o}{V_{IN}}\right)$$

$$\geq 3 \times (1 - 0.174)$$

$$\geq \underline{2.48 \text{ A}}$$

CH1

$$I_{Dip} \geq \left(I_o + \frac{V_o}{2L} \text{toff}\right)$$

$$\geq \underline{3.24 \text{ A}}$$

CH2

$$I_{Dip} \geq \left(I_o + \frac{V_o}{2L} \text{toff}\right)$$

$$\geq \underline{3.18 \text{ A}}$$

## • Smoothing Capacitor

The smoothing capacitor is an indispensable element for reducing ripple voltage in output. In selecting a smoothing capacitor it is essential to consider equivalent series resistance (ESR) and allowable ripple current. Higher ESR means higher ripple voltage, so that to reduce ripple voltage it is necessary to select a capacitor with low ESR. However, the use of a capacitor with low ESR can have substantial effects on loop phase characteristics, and therefore requires attention to system stability. Care should also be taken to use a capacity with sufficient margin for allowable ripple current. This application uses the (OS-CON™) 6SVP82M made by SANYO. The ESR, capacitance value, and ripple current can be calculated from the following formulas.

Equivalent Series Resistance : ESR

$$ESR \leq \frac{\Delta V_o}{\Delta I_L} - \frac{1}{2\pi f C_L}$$

Capacitance value :  $C_L$

$$C_L \geq \frac{\Delta I_L}{2\pi f (\Delta V_o - \Delta I_L \times ESR)}$$

Ripple current :  $I_{C_{Lrms}}$

$$I_{C_{Lrms}} \geq \frac{(V_{IN} - V_o) \text{ ton}}{2\sqrt{3}L}$$

Example: Using the 6SVP82M

Rated voltage = 6.3 V, ESR = 50 mΩ, maximum allowable ripple current = 1570 mArms

Equivalent series resistance

CH1

$$\begin{aligned} ESR &\leq \frac{\Delta V_o}{\Delta I_L} - \frac{1}{2\pi f C_L} \\ &\leq \frac{0.050}{0.491} - \frac{1}{2\pi \times 500 \times 10^3 \times 82 \times 10^{-6}} \\ &\leq \underline{98.0 \text{ m}\Omega} \end{aligned}$$

CH2

$$\begin{aligned} \text{ESR} &\leq \frac{\Delta V_o}{\Delta I_L} - \frac{1}{2\pi f C_L} \\ &\leq \frac{0.033}{0.364} - \frac{1}{2\pi \times 500 \times 10^3 \times 82 \times 10^{-6}} \\ &\leq \underline{86.8 \text{ m}\Omega} \end{aligned}$$

Capacitance value

CH1

$$\begin{aligned} C_L &\geq \frac{\Delta I_L}{2\pi f (\Delta V_o - \Delta I_L \times \text{ESR})} \\ &\geq \frac{0.491}{2\pi \times 500 \times 10^3 \times (0.050 - 0.491 \times 0.05)} \\ &\geq \underline{6.14 \mu\text{F}} \end{aligned}$$

CH2

$$\begin{aligned} C_L &\geq \frac{\Delta I_L}{2\pi f (\Delta V_o - \Delta I_L \times \text{ESR})} \\ &\geq \frac{0.364}{2\pi \times 500 \times 10^3 \times (0.033 - 0.364 \times 0.05)} \\ &\geq \underline{7.83 \mu\text{F}} \end{aligned}$$

Ripple current

CH1

$$\begin{aligned} I_{C_L \text{rms}} &\geq \frac{(V_{IN} - V_o) t_{on}}{2\sqrt{3}L} \\ &\geq \frac{(19 - 5) \times 0.263}{2\sqrt{3} \times 15 \times 10^{-6} \times 500 \times 10^3} \\ &\geq \underline{141.7 \text{ mArms}} \end{aligned}$$

CH2

$$\begin{aligned} I_{C_L \text{rms}} &\geq \frac{(V_{IN} - V_o) t_{on}}{2\sqrt{3}L} \\ &\geq \frac{(19 - 3.3) \times 0.174}{2\sqrt{3} \times 15 \times 10^{-6} \times 500 \times 10^3} \\ &\geq \underline{105.1 \text{ mArms}} \end{aligned}$$

## REFERENCE DATA

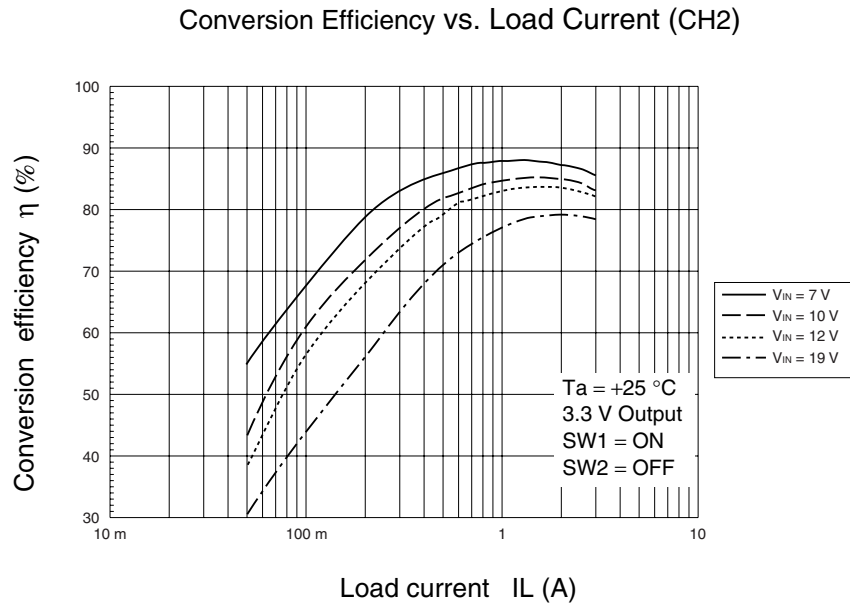
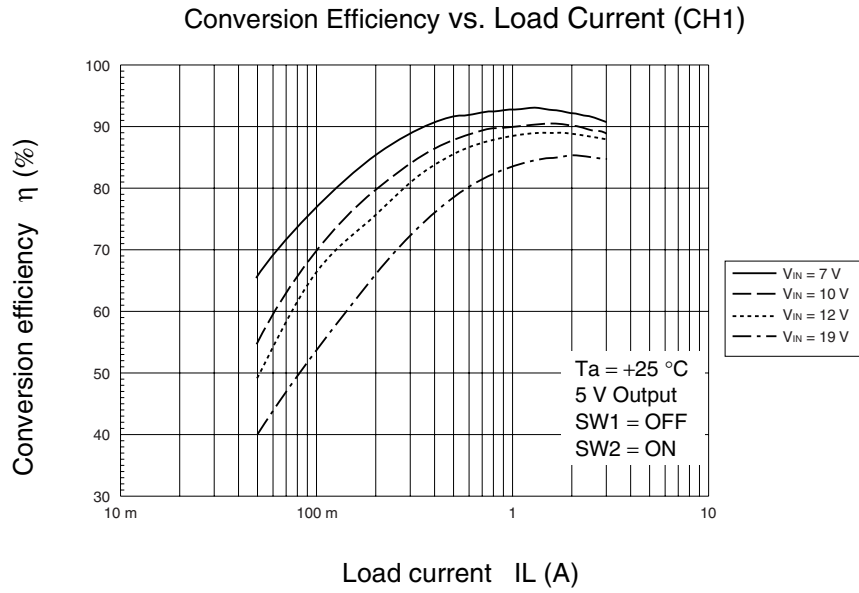

(Continued)

(Continued)

### Switching Wave Form (CH1)

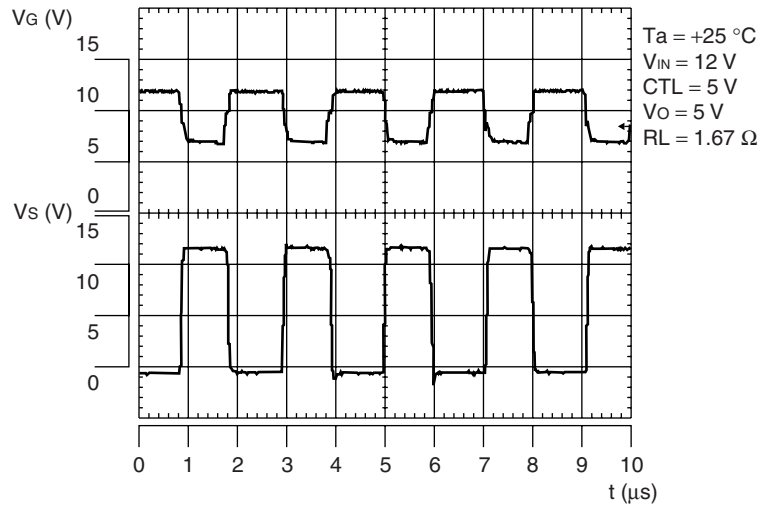

### Switching Wave Form (CH2)

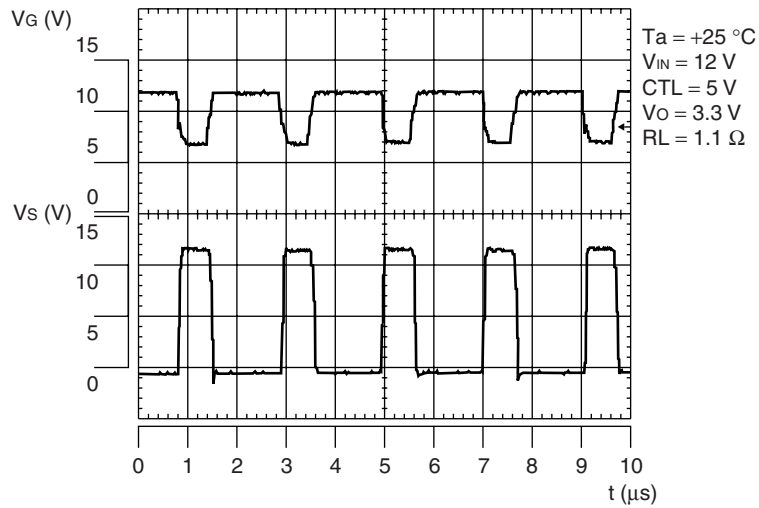

# MB39A104

## ■ USAGE PRECAUTIONS

- Printed circuit board ground lines should be set up with consideration for common impedance.
- Take appropriate static electricity measures.
  - Containers for semiconductor materials should have anti-static protection or be made of conductive material.
  - After mounting, printed circuit boards should be stored and shipped in conductive bags or containers.
  - Work platforms, tools, and instruments should be properly grounded.
  - Working personnel should be grounded with resistance of 250 kΩ to 1 MΩ between body and ground.
- Do not apply negative voltages.
  - The use of negative voltages below -0.3 V may create parasitic transistors on LSI lines, which can cause malfunction.

## ■ ORDERING INFORMATION

Part number	Package	Remarks
MB39A104PFV-□□□E1	24-pin plastic SSOP (FPT-24P-M03)	Lead Free version

## ■ EV BOARD ORDERING INFORMATION

EV board part No.	EV board version No.	Remarks
MB39A104EVB	Board Rev. 1.0	SSOP-24P

## ■ RoHS COMPLIANCE INFORMATION OF LEAD (Pb) FREE VERSION

The LSI products of Fujitsu Microelectronics with “E1” are compliant with RoHS Directive , and has observed the standard of lead, cadmium, mercury, Hexavalent chromium, polybrominated biphenyls (PBB) , and polybrominated diphenyl ethers (PBDE) .

The product that conforms to this standard is added “E1” at the end of the part number.

## ■ MARKING FORMAT (Lead Free version)

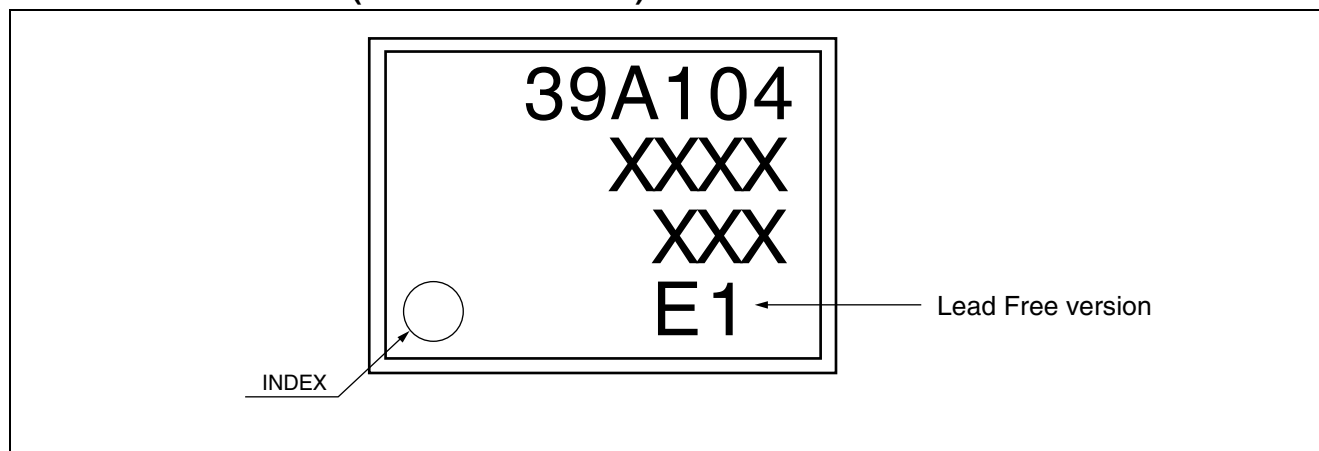

## ■ LABELING SAMPLE (LEAD FREE VERSION)



# MB39A104

## ■ MB39A104PFV-□□□E1

### RECOMMENDED CONDITIONS OF MOISTURE SENSITIVITY LEVEL

Item	Condition	
Mounting Method	IR (infrared reflow) , Manual soldering (partial heating method)	
Mounting times	2 times	
Storage period	Before opening	Please use it within two years after Manufacture.
	From opening to the 2nd reflow	Less than 8 days
	When the storage period after opening was exceeded	Please processes within 8 days after baking (125 °C, 24H)
Storage conditions	5 °C to 30 °C, 70%RH or less (the lowest possible humidity)	

#### [Temperature Profile for FJ Standard IR Reflow]

##### (1) IR (infrared reflow)

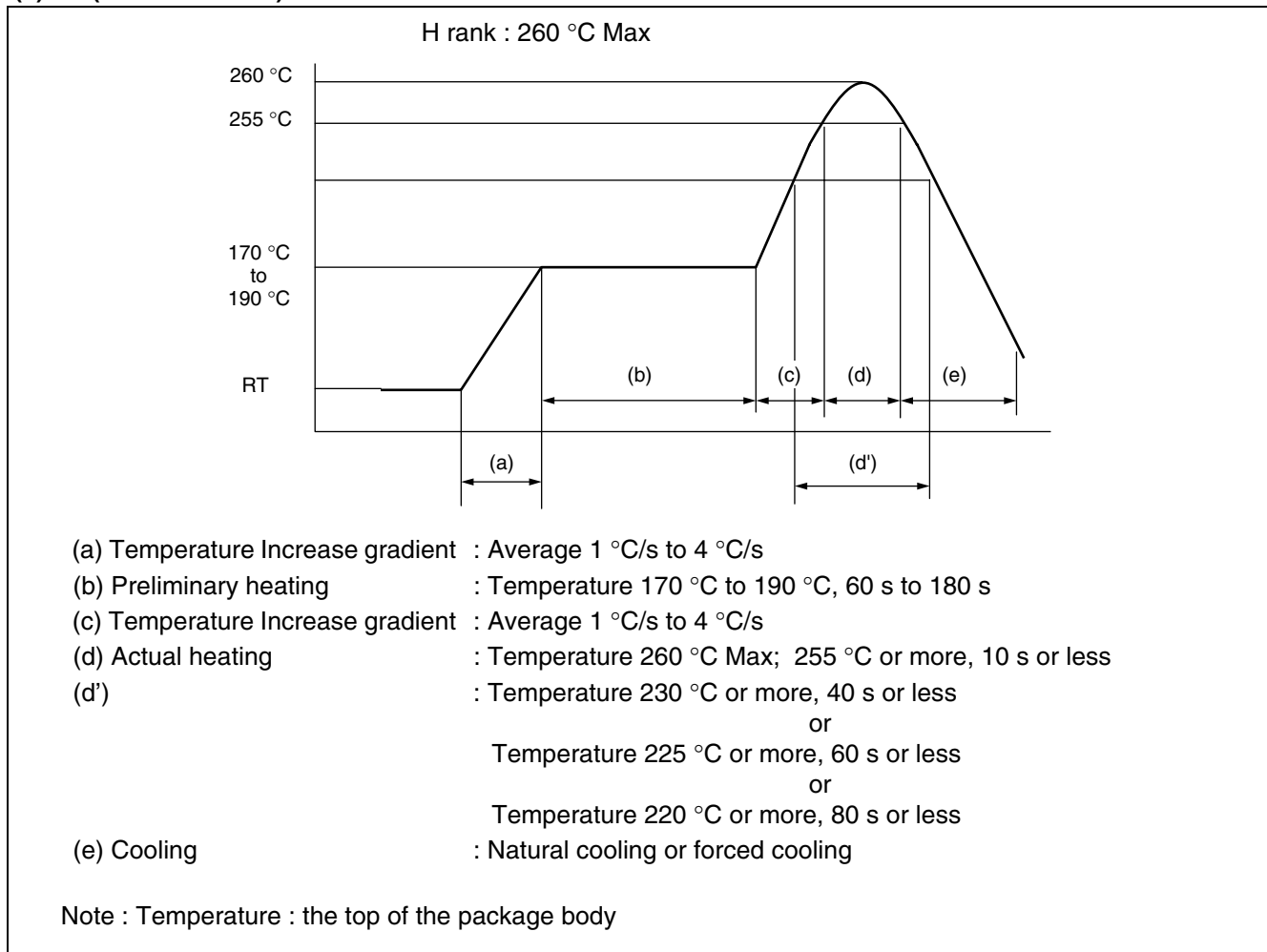

##### (2) Manual soldering (partial heating method)

Conditions : Temperature 400 °C Max

Times : 5 s max/pin

## ■ PACKAGE DIMENSION

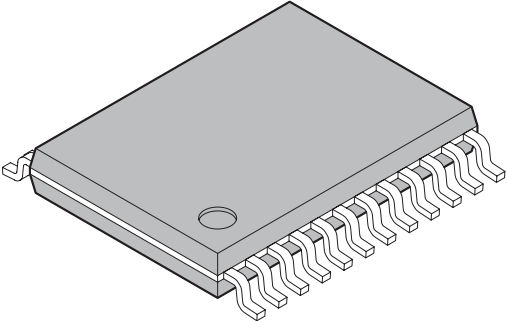
<p>24-pin plastic SSOP</p>  <p>(FPT-24P-M03)</p>	Lead pitch	0.65 mm
	Package width × package length	5.6 × 7.75 mm
	Lead shape	Gullwing
	Sealing method	Plastic mold
	Mounting height	1.45 mm MAX
	Weight	0.12 g
	Code (Reference)	P-SSOP24-5.6×7.75-0.65

24-pin plastic SSOP  
(FPT-24P-M03)

- Note 1) \*1 : Resin protrusion. (Each side : +0.15 (.006) Max).  
 Note 2) \*2 : These dimensions do not include resin protrusion.  
 Note 3) Pins width and pins thickness include plating thickness.  
 Note 4) Pins width do not include tie bar cutting remainder.

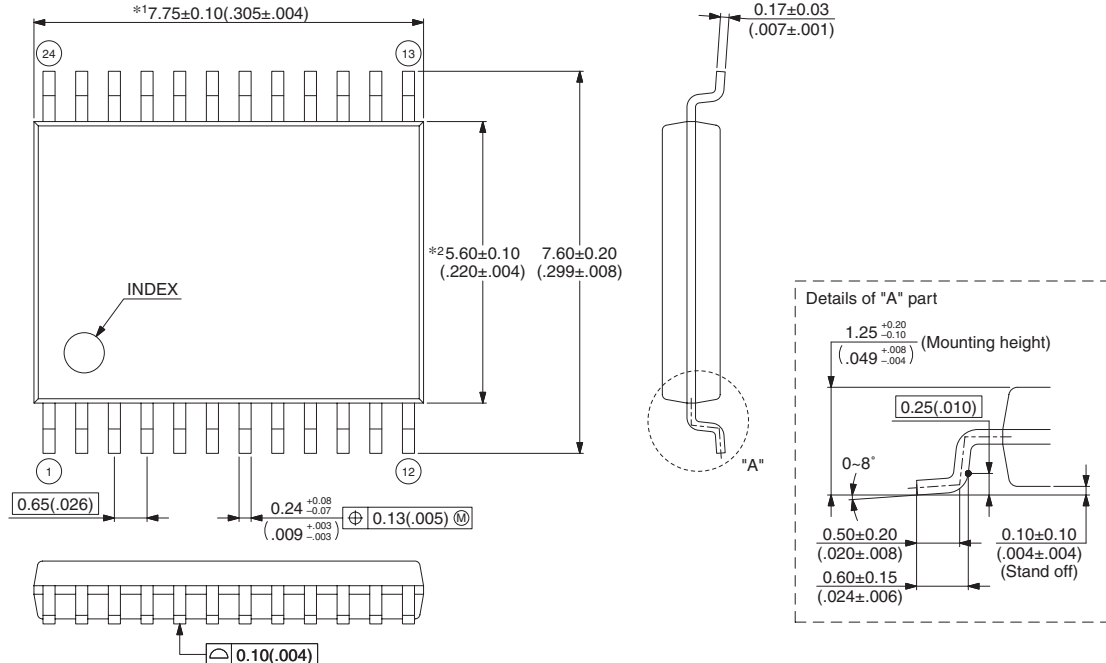

© 2003 FUJITSU LIMITED F24018S-c-4-5

Dimensions in mm (inches).  
 Note: The values in parentheses are reference values.

**MEMO**

**MEMO**

# FUJITSU MICROELECTRONICS LIMITED

Shinjuku Dai-Ichi Seimei Bldg. 7-1, Nishishinjuku 2-chome, Shinjuku-ku,  
Tokyo 163-0722, Japan Tel: +81-3-5322-3347 Fax: +81-3-5322-3387  
<http://jp.fujitsu.com/fml/en/>

*For further information please contact:*

## **North and South America**

FUJITSU MICROELECTRONICS AMERICA, INC.  
1250 E. Arques Avenue, M/S 333  
Sunnyvale, CA 94085-5401, U.S.A.  
Tel: +1-408-737-5600 Fax: +1-408-737-5999  
<http://www.fma.fujitsu.com/>

## **Europe**

FUJITSU MICROELECTRONICS EUROPE GmbH  
Pittlerstrasse 47, 63225 Langen,  
Germany  
Tel: +49-6103-690-0 Fax: +49-6103-690-122  
<http://emea.fujitsu.com/microelectronics/>

## **Korea**

FUJITSU MICROELECTRONICS KOREA LTD.  
206 KOSMO TOWER, 1002 Daechi-Dong,  
Kangnam-Gu, Seoul 135-280  
Korea  
Tel: +82-2-3484-7100 Fax: +82-2-3484-7111  
<http://www.fmk.fujitsu.com/>

## **Asia Pacific**

FUJITSU MICROELECTRONICS ASIA PTE LTD.  
151 Lorong Chuan, #05-08 New Tech Park,  
Singapore 556741  
Tel: +65-6281-0770 Fax: +65-6281-0220  
<http://www.fujitsu.com/sg/services/micro/semiconductor/>

FUJITSU MICROELECTRONICS SHANGHAI CO., LTD.  
Rm.3102, Bund Center, No.222 Yan An Road(E),  
Shanghai 200002, China  
Tel: +86-21-6335-1560 Fax: +86-21-6335-1605  
<http://cn.fujitsu.com/fmc/>

FUJITSU MICROELECTRONICS PACIFIC ASIA LTD.  
10/F., World Commerce Centre, 11 Canton Road  
Tsimshatsui, Kowloon  
Hong Kong  
Tel: +852-2377-0226 Fax: +852-2376-3269  
<http://cn.fujitsu.com/fmc/tw>

All Rights Reserved.

The contents of this document are subject to change without notice.

Customers are advised to consult with sales representatives before ordering.

The information, such as descriptions of function and application circuit examples, in this document are presented solely for the purpose of reference to show examples of operations and uses of FUJITSU MICROELECTRONICS device; FUJITSU MICROELECTRONICS does not warrant proper operation of the device with respect to use based on such information. When you develop equipment incorporating the device based on such information, you must assume any responsibility arising out of such use of the information.

FUJITSU MICROELECTRONICS assumes no liability for any damages whatsoever arising out of the use of the information.

Any information in this document, including descriptions of function and schematic diagrams, shall not be construed as license of the use or exercise of any intellectual property right, such as patent right or copyright, or any other right of FUJITSU MICROELECTRONICS or any third party or does FUJITSU MICROELECTRONICS warrant non-infringement of any third-party's intellectual property right or other right by using such information. FUJITSU MICROELECTRONICS assumes no liability for any infringement of the intellectual property rights or other rights of third parties which would result from the use of information contained herein.

The products described in this document are designed, developed and manufactured as contemplated for general use, including without limitation, ordinary industrial use, general office use, personal use, and household use, but are not designed, developed and manufactured as contemplated (1) for use accompanying fatal risks or dangers that, unless extremely high safety is secured, could have a serious effect to the public, and could lead directly to death, personal injury, severe physical damage or other loss (i.e., nuclear reaction control in nuclear facility, aircraft flight control, air traffic control, mass transport control, medical life support system, missile launch control in weapon system), or (2) for use requiring extremely high reliability (i.e., submersible repeater and artificial satellite).

Please note that FUJITSU MICROELECTRONICS will not be liable against you and/or any third party for any claims or damages arising in connection with above-mentioned uses of the products.

Any semiconductor devices have an inherent chance of failure. You must protect against injury, damage or loss from such failures by incorporating safety design measures into your facility and equipment such as redundancy, fire protection, and prevention of over-current levels and other abnormal operating conditions.

Exportation/release of any products described in this document may require necessary procedures in accordance with the regulations of the Foreign Exchange and Foreign Trade Control Law of Japan and/or US export control laws.

The company names and brand names herein are the trademarks or registered trademarks of their respective owners.