

## ASSP For Power Management Applications

# 6-ch DC/DC Converter IC with Synchronous Rectifier for Voltage Step-up and Step-down

## MB3883

### ■ DESCRIPTION

The MB3883 is a 6-channel step-up/step-down DC/DC converter IC using pulse width modulation (PWM) and synchronous rectification, designed for low voltage, high efficiency, and compact size. This IC is ideal for up conversion, down conversion, and up/down conversion (using a step-up/step-down Zeta system with free input and output settings).

The MB3883 can operate at low voltage levels, and has a wide supply voltage range from 1.7 V to 9 V.

The MB3883 is available in two packages, an LQFP-48P or a leadless BCC-48P formed with a contact electrode pad only.

This is an ideal power supply for high-performance portable devices such as digital still cameras.

This product is covered by US Patent Number 6,147,477.

### ■ FEATURES

- Supports synchronous rectification (CH1, 2, 5)
- Supports for down-conversion and up/down Zeta conversion (CH1, 2)  
Supports for up-conversion (CH5)
- Supports up-conversion (CH3, 4, 6)
- Low start-up voltage : 1.7 V (CH6)

(Continued)

### ■ PACKAGES

48-pin plastic LQFP

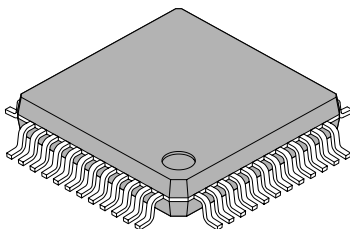

(FPT-48P-M05)

48-pad plastic BCC

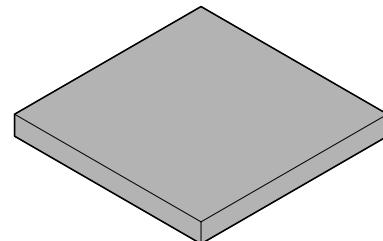

(LCC-48P-M02)

# MB3883

*(Continued)*

- Power supply voltage range : 2.4 V to 9 V (CH6)  
: 3.6 V to 9 V (CH1 to CH5)
- Built-in high-precision reference voltage circuit :  $\pm 1\%$
- Wide operating oscillator frequency range with high-frequency capability : 100 kHz to 1 MHz
- Error amplifier output for soft start (CH1 to CH6)
- Totem-pole type output switch control circuit

## PIN ASSIGNMENTS

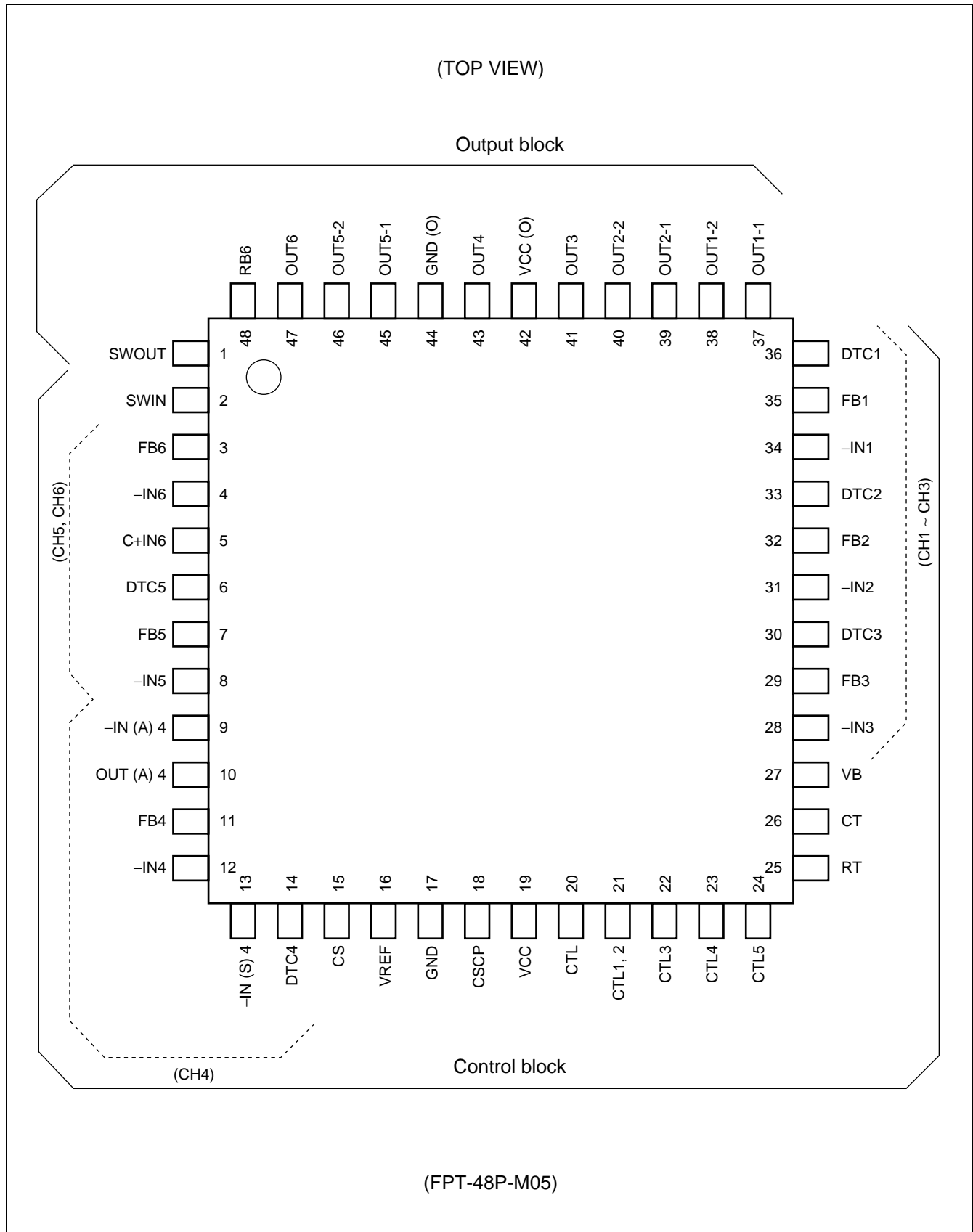



## ■ PIN DESCRIPTION

Pin No.	Symbol	I/O	Descriptions	
CH1	35	FB1	O	Error amplifier output pin.
	34	-IN1	I	Error amplifier inverted input pin.
	36	DTC1	I	Dead time control pin.
	37	OUT1-1	O	Main side output pin.
	38	OUT1-2	O	Synchronous rectifier side output pin.
CH2	32	FB2	O	Error amplifier output pin.
	31	-IN2	I	Error amplifier inverted input pin.
	33	DTC2	I	Dead time control pin.
	39	OUT2-1	O	Main side output pin.
	40	OUT2-2	O	Synchronous rectifier side output pin.
CH3	29	FB3	O	Error amplifier output pin.
	28	-IN3	I	Error amplifier inverted input pin.
	30	DTC3	I	Dead time control pin.
	41	OUT3	O	Output pin.
CH4	11	FB4	O	Error amplifier output pin.
	12	-IN4	I	Error amplifier inverted input pin.
	14	DTC4	I	Dead time control pin.
	43	OUT4	O	Output pin.
	9	-IN (A) 4	I	Inverting amplifier input pin.
	10	OUT (A) 4	O	Inverting amplifier output pin.
	13	-IN (S) 4	I	Short detection comparator inverted input pin.
CH5	7	FB5	O	Error amplifier output pin.
	8	-IN5	I	Error amplifier inverted input pin.
	6	DTC5	I	Dead time control pin.
	45	OUT5-1	O	Main side output pin.
	46	OUT5-2	O	Synchronous rectifier side output pin.
CH6	3	FB6	O	Error amplifier output pin.
	4	-IN6	I	Error amplifier inverted input pin.
	5	C+IN6	I	Soft start capacitor connection pin.
	48	RB6	O	Output current setting resistor connection pin.
	47	OUT6	O	Output pin.

(Continued)

# MB3883

(Continued)

Pin No.	Symbol	I/O	Descriptions	
OSC	25	RT	—	Triangular wave frequency setting resistor connection pin.
	26	CT	—	Triangular wave frequency setting capacitor connection pin.
	27	VB	O	Triangular wave oscillator regulator output pin.
Control	1	SWOUT	O	Output switch control circuit output pin.
	2	SWIN	I	Output switch control circuit input pin.
	20	CTL	I	Power supply, CH6 control pin. “H” level : Power supply CH6 operating mode “L” level : Standby mode
	21	CTL1, 2	I	CH1, CH2 control pin. When CTL1, 2 pin = “H” level “H” level : CH1, CH2 operating mode “L” level : CH1, CH2 OFF mode
	22	CTL3	I	CH3 control pin. When CTL3 pin = “H” level “H” level : CH3 operating mode “L” level : CH3 OFF mode
	23	CTL4	I	CH4 control pin. When CTL4 pin = “H” level “H” level : CH4 operating mode “L” level : CH4 OFF mode
	24	CTL5	I	CH5 control pin. When CTL5 pin = “H” level “H” level : CH5 operating mode “L” level : CH5 OFF mode
	18	CSCP	—	Short protection circuit capacitor connection pin.
	15	CS	—	CH1to CH5 soft start circuit capacitor connection pin.
Power	19	VCC	—	Reference voltage and control circuit power supply pin.
	42	VCC (O)	—	Output circuit power supply pin.
	16	VREF	O	Reference voltage output pin.
	17	GND	—	Ground pin.
	44	GND (O)	—	Output circuit ground pin.

## ■ BLOCK DIAGRAM

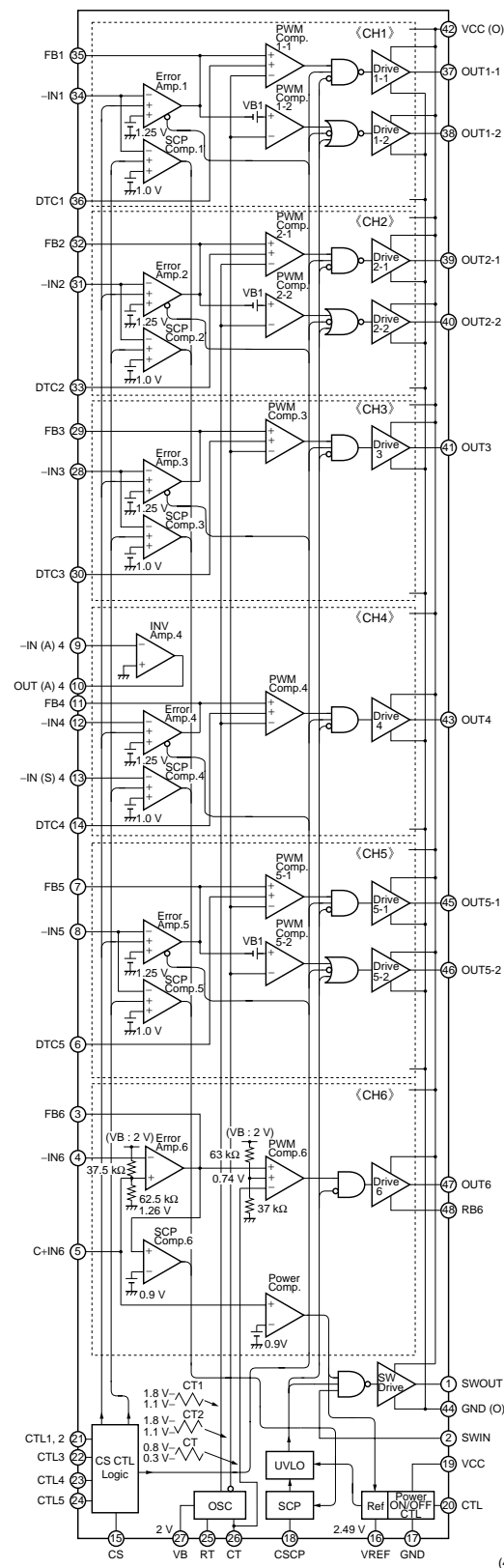

H : ON (Power/CH6)  
L : OFF (Standby mode)

(48 Pin)

# MB3883

• Block diagram (Expansion 1/2)

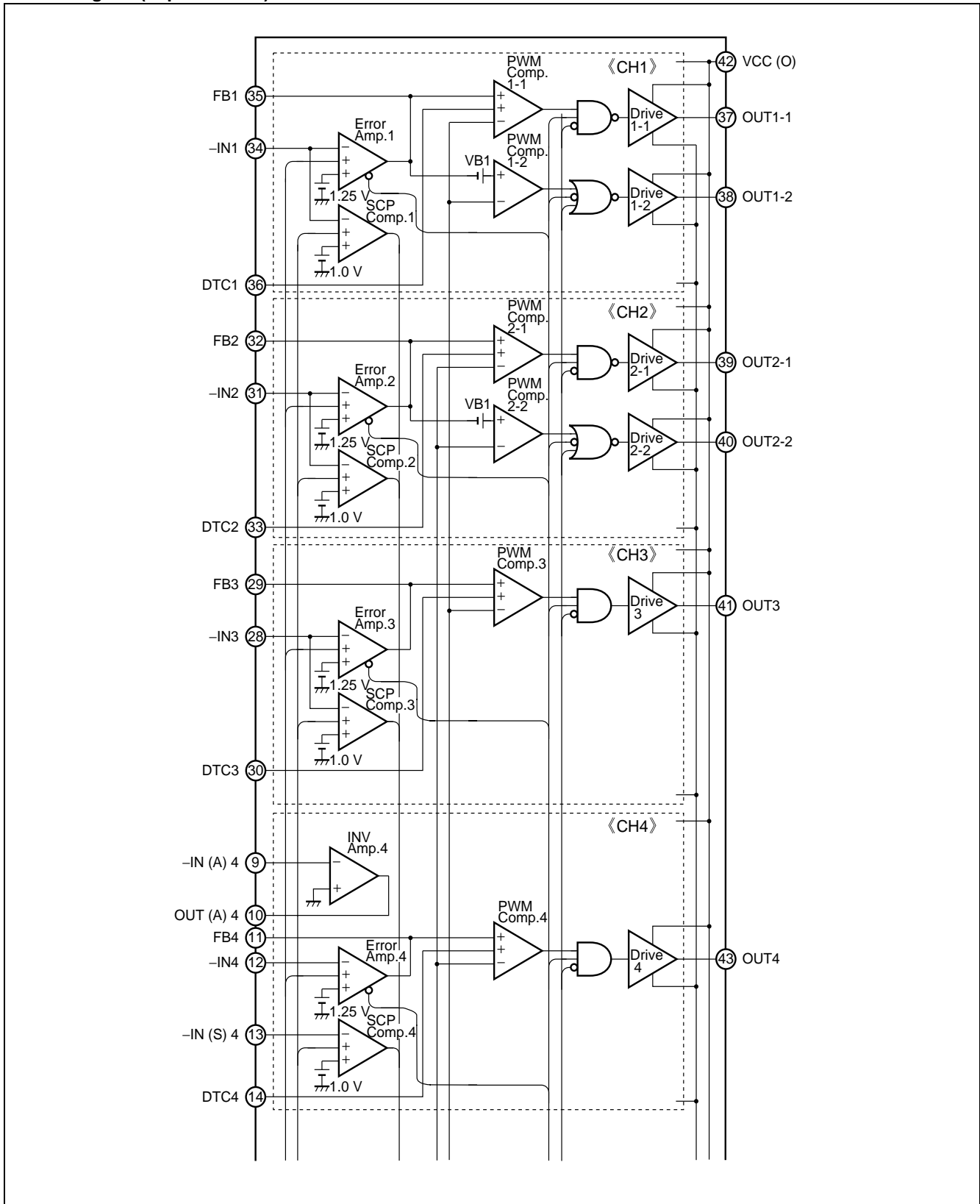

• Block diagram (Expansion 2/2)

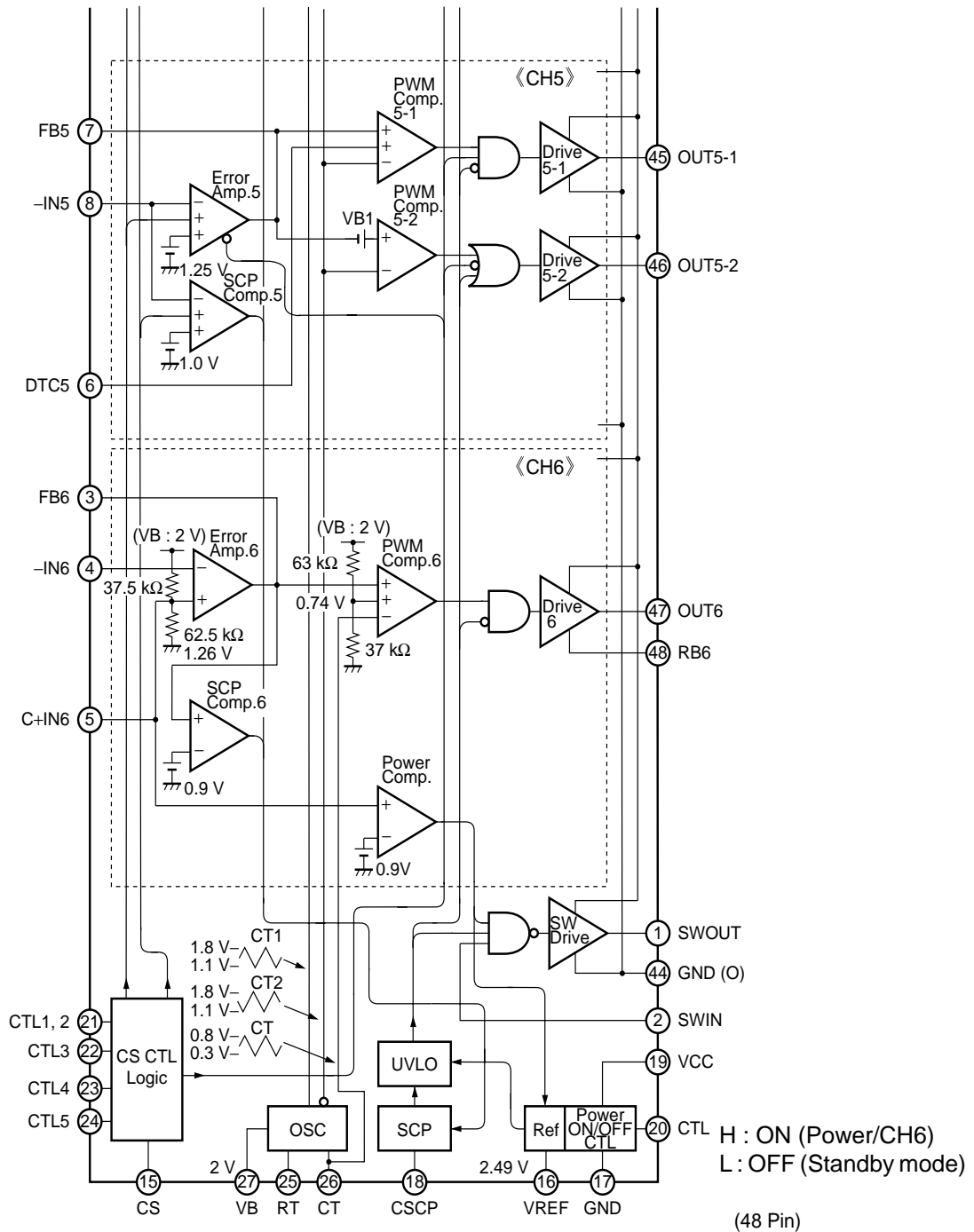

## ■ ABSOLUTE MAXIMUM RATINGS

Parameter	Symbol	Condition	Rating		Unit
			Min.	Max.	
Power supply voltage	$V_{CC}$	—	—	10	V
	$I_o$	OUT pin	—	20	mA
Output current	$I_o$	OUT pin, Duty $\leq$ 5%	—	200	mA
Output peak current	$P_D$	$T_a \leq +25\text{ }^\circ\text{C}$ (LQFP-48P)	—	860*	mW
Power dissipation		$T_a \leq +25\text{ }^\circ\text{C}$ (BCC-48P)	—	710*	mW
Storage temperature	$T_{stg}$	—	-55	+125	$^\circ\text{C}$

\* : The packages are mounted on the epoxy board (10 cm  $\times$  10 cm).

WARNING: Semiconductor devices can be permanently damaged by application of stress (voltage, current, temperature, etc.) in excess of absolute maximum ratings. Do not exceed these ratings.

## ■ RECOMMENDED OPERATING CONDITIONS

Parameter	Symbol	Condition	Value			Unit
			Min.	Typ.	Max.	
Startup power supply voltage	$V_{CC}$	CH6	1.7	—	9	V
Power supply voltage	$V_{CC}$	CH6	2.4	5.0	9	V
		CH1 to CH5	3.6	5.0	9	V
Reference voltage output current	$I_{OR}$	VREF pin	-1	—	0	mA
VB pin output current	$I_B$	VB pin	-0.5	—	0	mA
Input voltage	$V_{IN}$	-IN1 to -IN5, -IN (A) 4, -IN (S) 4 pin	0	—	$V_{CC} - 1.8$	V
		-IN6 pin	0	—	$V_{CC} - 0.9$	V
Control input voltage	$V_{CTL}$	CTL pin	0	—	9	V
Output current	$I_o$	OUT pin (CH1 to CH5)	—	2	15	mA
		OUT pin (CH6)	1	2	15	mA
		SWOUT pin	—	1	4	mA
Output current setting resistor	$R_B$	RB6 pin	2.4	24	51	k $\Omega$
Oscillator frequency	$f_{osc}$	—	100	500	1000	kHz
Timing capacitor	$C_T$	—	47	100	560	pF
Timing resistor	$R_T$	—	8.2	18	100	k $\Omega$
Soft-start capacitor	$C_S$	CH1 to CH5	—	0.027	1.0	$\mu$ F
	$C_{+IN6}$	CH6	—	0.47	1.0	$\mu$ F
Short detection capacitor	$C_{SCP}$	—	—	0.1	1.0	$\mu$ F
VB pin capacitor	$C_{VB}$	—	0.082	0.18	—	$\mu$ F
Operating ambient temperature	$T_a$	—	-30	25	85	$^{\circ}$ C

**WARNING:** The recommended operating conditions are required in order to ensure the normal operation of the semiconductor device. All of the device's electrical characteristics are warranted when the device is operated within these ranges.

Always use semiconductor devices within their recommended operating condition ranges. Operation outside these ranges may adversely affect reliability and could result in device failure.

No warranty is made with respect to uses, operating conditions, or combinations not represented on the data sheet. Users considering application outside the listed conditions are advised to contact their FUJITSU representatives beforehand.

## ELECTRICAL CHARACTERISTICS

(Ta = +25 °C, VCC = 5 V)

Parameter	Symbol	Pin No.	Conditions	Value			Unit		
				Min.	Typ.	Max.			
Reference voltage block [REF]	Reference voltage	V <sub>REF</sub>	16	—	2.46	2.49	2.51	V	
	Output voltage temperature stability	$\Delta V_{REF} / V_{REF}$	16	Ta = -30 °C to +85 °C	—	0.5*	—	%	
	Input stability	Line	16	VCC = 3.6 V to 9 V	-10	—	10	mV	
	Load stability	Load	16	VREF = 0 mA to -1 mA	-10	—	10	mV	
	Short-circuit output current	I <sub>OS</sub>	16	VREF = 2 V	-20	-5	-1	mA	
Under voltage lockout protection circuit block [U.V.L.O.]	CH1 to CH5	Threshold voltage	V <sub>TH</sub>	37	VCC = $\bar{\downarrow}$	2.6	2.8	3.0	V
		Hysteresis width	V <sub>H</sub>	37	—	—	0.2	—	V
		Reset voltage	V <sub>RST</sub>	37	VCC = $\bar{\uparrow}$	1.20	1.30	1.40	V
	CH6	Threshold voltage	V <sub>TH</sub>	47	VCC = $\bar{\downarrow}$	1.35	1.5	1.65	V
Soft-start block [CS]	Input standby voltage	V <sub>STB</sub>	15	—	—	50	100	mV	
	Charge current	I <sub>CS</sub>	15	—	-1.4	-1.0	-0.6	μA	
Short circuit detection block [SCP]	Threshold voltage	V <sub>TH</sub>	18	—	0.65	0.70	0.75	V	
	Input standby voltage	V <sub>STB</sub>	18	—	—	50	100	mV	
	Input latch voltage	V <sub>I</sub>	18	—	—	50	100	mV	
	Input source current	I <sub>CSCP</sub>	18	—	-1.4	-1.0	-0.6	μA	
Triangular wave oscillator block [OSC]	Oscillator frequency	f <sub>OSC</sub>	37, 38, 39, 40, 41, 43, 45, 46, 47	CT = 100 pF, RT = 18 kΩ VB = 2 V	450	500	550	kHz	
	Frequency stability for voltage	$\Delta f / f_{dv}$	37, 38, 39, 40, 41, 43, 45, 46, 47	VCC = 3.6 V to 9 V	—	1	10	%	
	Frequency stability for temperature	$\Delta f / f_{dt}$	37, 38, 39, 40, 41, 43, 45, 46, 47	Ta = -30 °C to +85 °C	—	1*	—	%	

\*: Standard design value.

(Continued)

(Ta = +25 °C, VCC = 5 V)

Parameter	Symbol	Pin No.	Conditions	Value			Unit	
				Min.	Typ.	Max.		
Error amplifier block (CH1 to CH5) [Error Amp.]	Threshold voltage	V <sub>TH</sub>	35, 32, 29, 11, 7	FB = 1.45 V	1.23	1.25	1.27	V
	V <sub>T</sub> temperature stability	ΔV <sub>T</sub> /V <sub>T</sub>	35, 32, 29, 11, 7	Ta = -30 °C to +85 °C	—	0.5*	—	%
	Input bias current	I <sub>B</sub>	34, 31, 28, 8	-IN = 0 V (CH1 to CH3, CH5)	-320	-80	—	nA
			12	-IN = 0 V (CH4)	-120	-30	—	nA
	Voltage gain	A <sub>V</sub>	35, 32, 29, 11, 7	DC	60	100	—	dB
	Frequency bandwidth	BW	35, 32, 29, 11, 7	A <sub>V</sub> = 0 dB	—	1.0*	—	MHz
	Output voltage	V <sub>OH</sub>	35, 32, 29, 11, 7	—	2.2	2.4	—	V
		V <sub>OL</sub>	35, 32, 29, 11, 7	—	—	50	200	mV
	Output source current	I <sub>SOURCE</sub>	35, 32, 29, 11, 7	FB = 1.45 V	—	-2.0	-1.0	mA
Output sink current	I <sub>SINK</sub>	35, 32, 29, 11, 7	FB = 1.45 V	70	140	—	μA	
Error amplifier block (CH6) [Error Amp.]	Threshold voltage	V <sub>TH</sub>	3	FB = 0.55 V	1.24	1.26	1.28	V
	V <sub>T</sub> temperature stability	ΔV <sub>T</sub> /V <sub>T</sub>	3	Ta = -30 °C to +85 °C	—	0.5*	—	%
	Input bias current	I <sub>B</sub>	4	-IN = 0 V	-100	-20	—	nA
	Voltage gain	A <sub>V</sub>	3	DC	60	75	—	dB
	Frequency bandwidth	BW	3	A <sub>V</sub> = 0 dB	—	1.0*	—	MHz
	Output voltage	V <sub>OH</sub>	3	—	1.1	1.3	—	V
		V <sub>OL</sub>	3	—	—	0	200	mV
	Output source current	I <sub>SOURCE</sub>	3	FB = 0.55 V	—	-2.0	-1.0	mA
	Output sink current	I <sub>SINK</sub>	3	FB = 0.55 V	60	120	—	μA
Inverting amplifier block (CH4) [Inv Amp.]	Input offset voltage	V <sub>IO</sub>	10	OUT = 1.25 V	-10	0	10	mV
	Input bias current	I <sub>B</sub>	9	-IN = 0 V	-120	-30	—	nA
	Voltage gain	A <sub>V</sub>	10	DC	60	100	—	dB
	Frequency bandwidth	BW	10	A <sub>V</sub> = 0 dB	—	1.0*	—	MHz
	Output voltage	V <sub>OH</sub>	10	—	2.2	2.4	—	V
		V <sub>OL</sub>	10	—	—	50	200	mV
	Output source current	I <sub>SOURCE</sub>	10	OUT = 1.25 V	—	-2.0	-1.0	mA
Output sink current	I <sub>SINK</sub>	10	OUT = 1.25 V	70	140	—	μA	

\*: Standard design value.

(Continued)

(Ta = +25 °C, VCC = 5 V)

Parameter		Symbol	Pin No.	Conditions	Value			Unit
					Min.	Typ.	Max.	
Short detection comparator block (CH1 to CH5) [SCP Comp.]	Threshold voltage	$V_{TH}$	37, 38, 39, 40, 41, 43, 45, 46	CH1 to CH5	0.97	1.00	1.03	V
	Input bias current	$I_B$	34, 31, 28, 8	-IN = 0 V (CH1 to CH3, CH5)	-320	-80	—	nA
			13	-IN = 0 V (CH4)	-200	-50	—	nA
Short detection comparator block (CH6) [SCP Comp.]	Threshold voltage	$V_{TH}$	47	—	0.8	0.9	1.0	V
PWM Comp. block (CH1 to CH5) [PWM Comp.]	Threshold voltage	$V_{T0}$	37, 39, 41, 43, 45	Duty cycle = 0 %	1.0	1.1	—	V
		$V_{T100}$	37, 39, 41, 43, 45	Duty cycle = 100 %	—	1.8	1.9	V
	Input current	$I_{DTC}$	36, 33, 30, 14, 6	DTC = 0.4 V (CH1 to CH5)	-1.0	-0.3	—	$\mu$ A
PWM Comp. block (CH6) [PWM Comp.]	Threshold voltage	$V_{T0}$	47	Duty cycle = 0 %	0.2	0.3	—	V
		$V_{Tmax}$	47	Duty cycle = Max.	—	0.74	0.84	V
	Maximum duty cycle	Dtr	47	CT = 100 pF, RT = 18 k $\Omega$ , RB = 24 k $\Omega$	70	80	90	%
Output block (CH1, CH2, CH5) [Drive-1(Pch MOS)]	Output source current	$I_{SOURCE}$	37, 39, 45	Duty $\leq$ 5 %, OUT = 0 V	—	-130	-80	mA
	Output sink current	$I_{SINK}$	37, 39, 45	Duty $\leq$ 5 %, OUT = 5 V	65	100	—	mA
	Output ON resistor	$R_{OH}$	37, 39, 45	OUT = -15 mA	—	18	30	$\Omega$
		$R_{OL}$	37, 39, 45	OUT = 15 mA	—	16	25	$\Omega$
Output block (CH1 to CH5) [Drive-2(Nch MOS)]	Output source current	$I_{SOURCE}$	38, 40, 41, 43, 46	Duty $\leq$ 5 %, OUT = 0 V	—	-130	-80	mA
	Output sink current	$I_{SINK}$	38, 40, 41, 43, 46	Duty $\leq$ 5 %, OUT = 5 V	65	100	—	mA
	Output ON resistor	$R_{OH}$	38, 40, 41, 43, 46	OUT = -15 mA	—	18	30	$\Omega$
		$R_{OL}$	38, 40, 41, 43, 46	OUT = 15 mA	—	16	25	$\Omega$
Output block (CH6) [Drive]	Output source current	$I_{SOURCE}$	47	RB = 24 k $\Omega$ , OUT = 0.7 V	-2.6	-2.0	-1.4	mA
	Output sink current	$I_{SINK}$	47	Duty $\leq$ 5 %, OUT = 0.7 V	—	40	—	mA

\*: Standard design value.

(Continued)

(Continued)

(Ta = +25 °C, VCC = 5 V)

Parameter	Symbol	Pin No.	Conditions	Value			Unit	
				Min.	Typ.	Max.		
Output switch control block (Drive-1) [SW1]	SW input voltage	V <sub>IH</sub>	5	SWOUT = "L" level	1.5	—	9	V
		V <sub>IL</sub>	5	SWOUT = "H" level	0	—	0.5	V
	Input current	I <sub>SWIN</sub>	5	SWIN = 5 V	—	100	200	μA
	Output source current	I <sub>SOURCE</sub>	1	Duty ≤ 5 %, SWOUT = 0 V	—	-9	—	mA
	Output sink current	I <sub>SINK</sub>	1	Duty ≤ 5 %, SWOUT = 5 V	—	17	—	mA
	Output ON resistor	R <sub>OH</sub>	1	SWOUT = -4 mA	—	250	400	Ω
		R <sub>OL</sub>	1	SWOUT = 4 mA	—	100	150	Ω
Control block (CTL, CTL1 to CTL5) [CTL]	CTL input voltage	V <sub>IH</sub>	20, 21, 22, 23, 24	Active mode	1.5	—	9	V
		V <sub>IL</sub>	20, 21, 22, 23, 24	Standby mode	0	—	0.5	V
	Input current	I <sub>CTL</sub>	20, 21, 22, 23, 24	CTL = 5 V	—	100	200	μA
General	Standby current	I <sub>CCS</sub>	19	CTL = 0 V	—	—	10	μA
		I <sub>CCS</sub> (o)	42	CTL = 0 V	—	—	10	μA
	Power supply current	I <sub>CC</sub>	19, 42	CTL = CTL1, 2 = CTL3 = CTL4 = CTL5 = 5 V	—	6	9	mA

\*: Standard design value.

## ■ TYPICAL CHARACTERISTICS

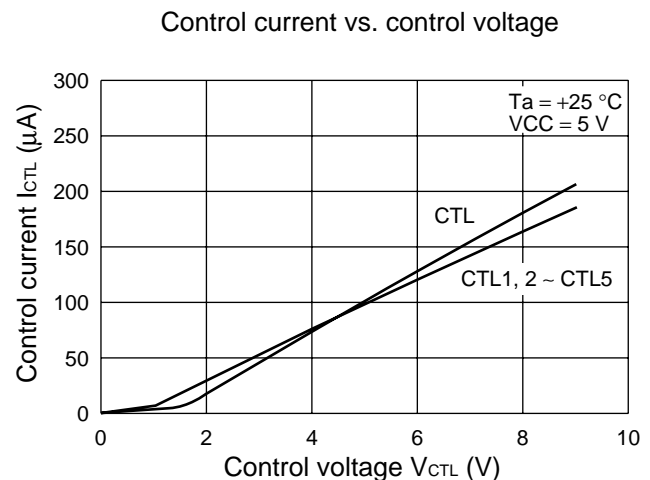
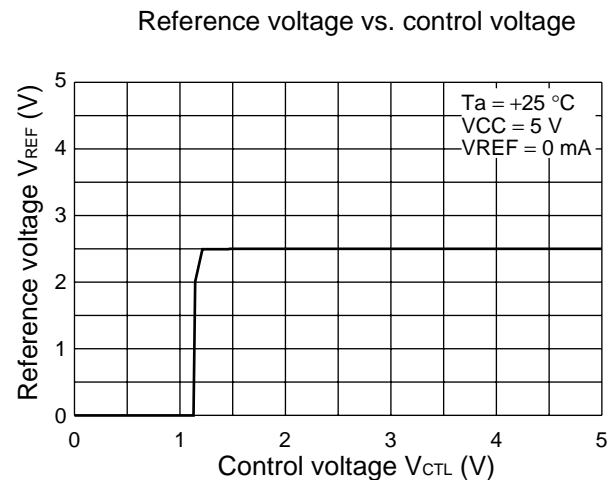
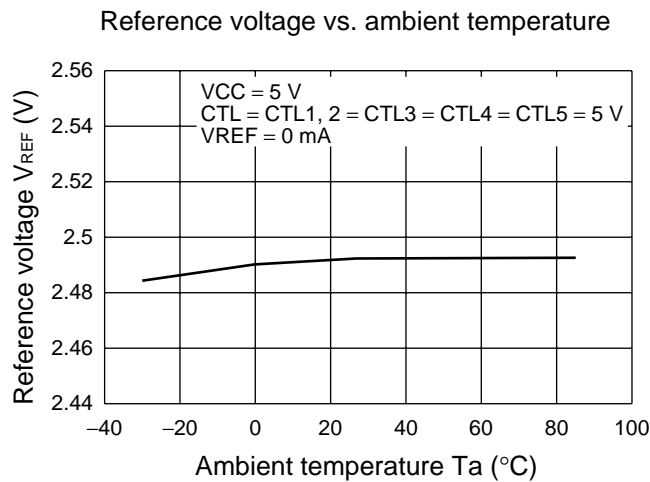
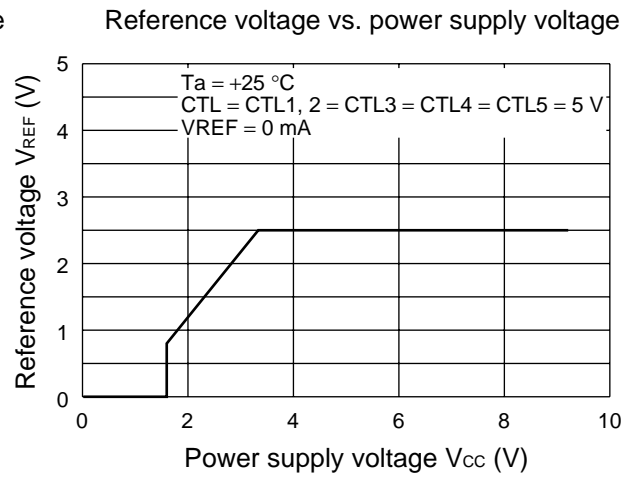
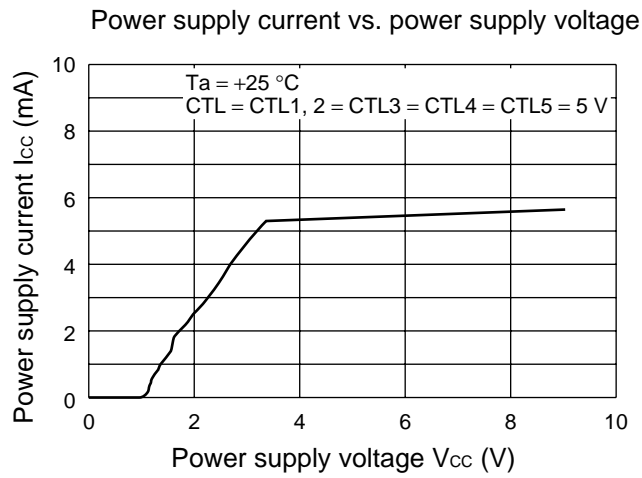

(Continued)

Triangular wave upper and lower limit voltage vs. triangular wave oscillator frequency

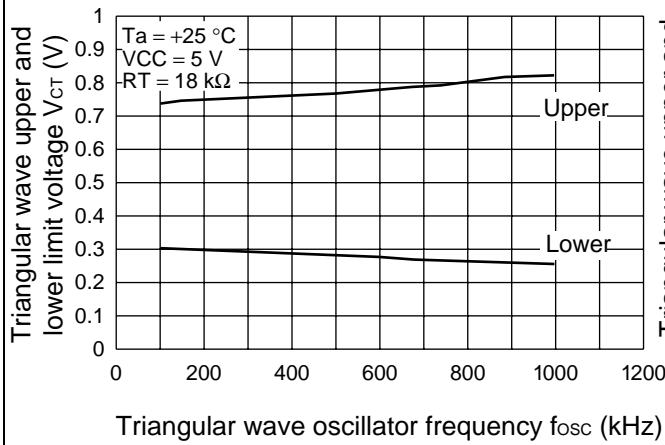

Triangular wave upper and lower limit voltage vs. ambient temperature

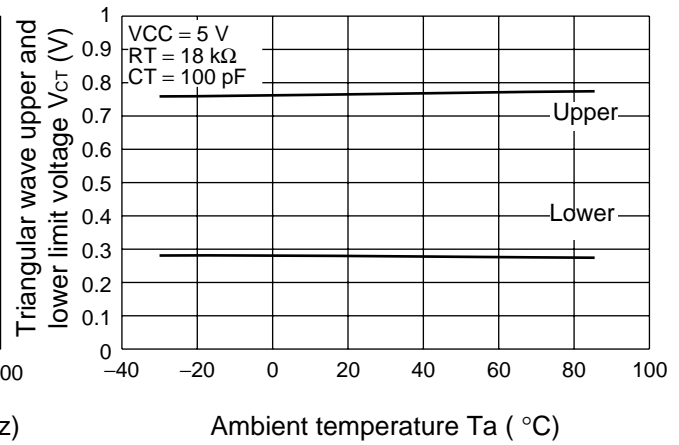

Triangular wave oscillator frequency vs. timing capacitor

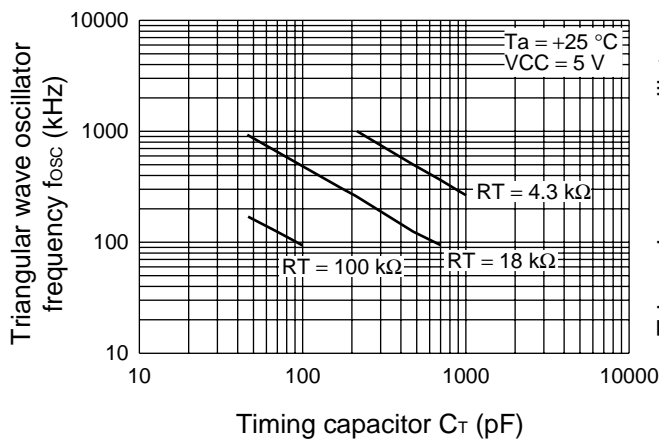

Triangular wave oscillator frequency vs. timing resistor

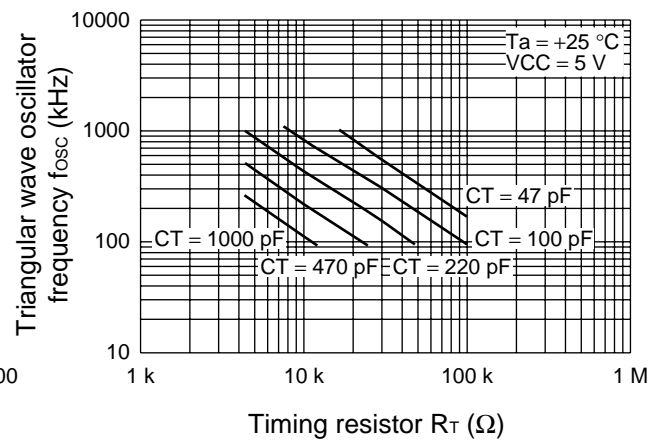

Triangular wave oscillator frequency vs. ambient temperature

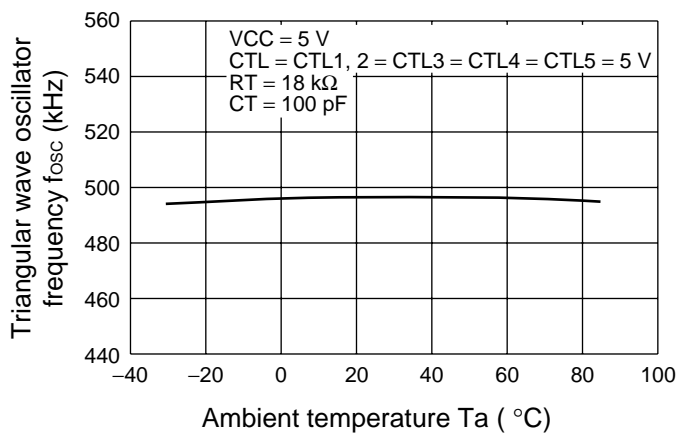

(Continued)

(Continued)

Error amplifier gain and phase vs. frequency (CH1)

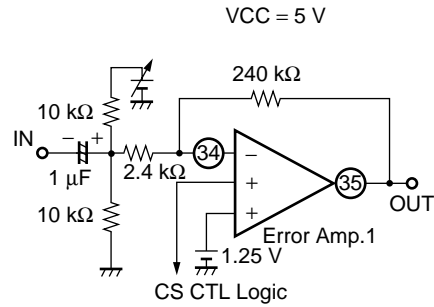
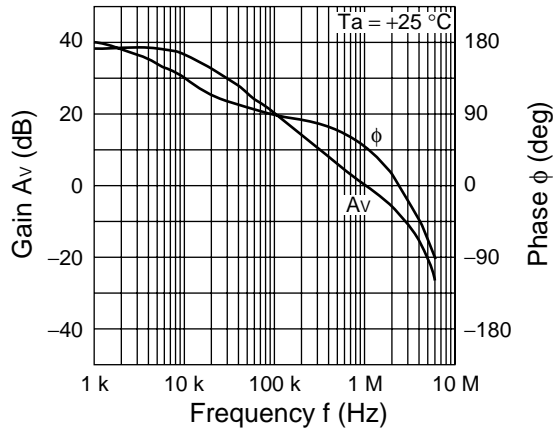

Error amplifier gain and phase vs. frequency (CH6)

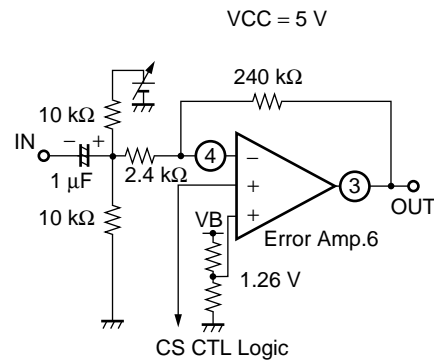
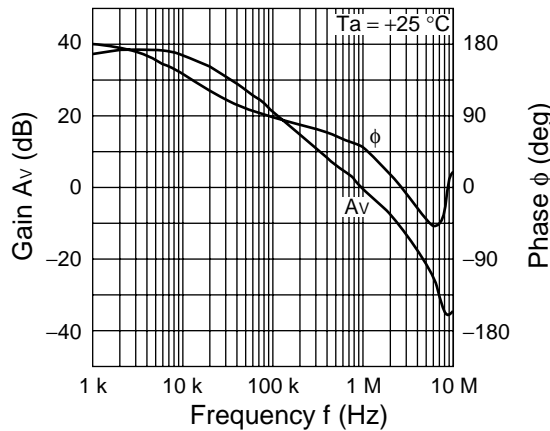

Power dissipation vs. ambient temperature (LQFP-48P)

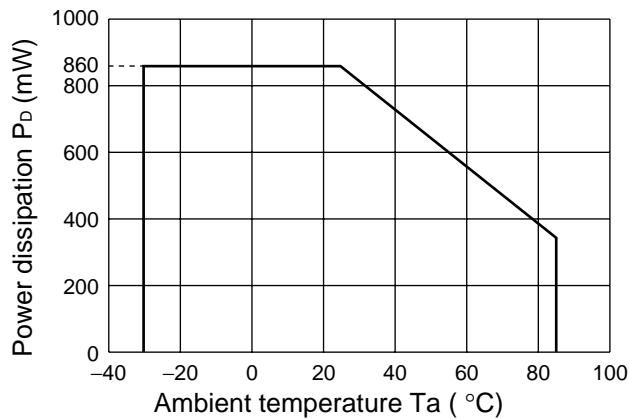

Power dissipation vs. ambient temperature (BCC-48P)

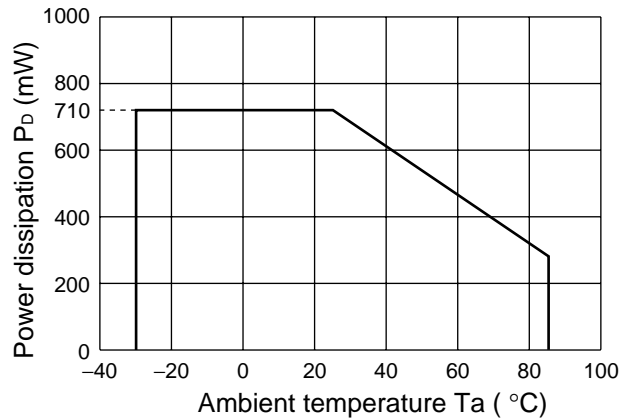

## ■ FUNCTIONS

### 1. DC-DC Converter Functions

#### (1) Reference voltage block

The reference voltage circuit generates a temperature-compensated reference voltage (typically  $\approx 2.49$  V) from the voltage supplied from the power supply terminal (pin 19). The voltage is used as the reference voltage for the IC's internal circuitry.

The reference voltage can supply a load current of up to 1 mA to an external device through the VREF terminal (pin 16).

#### (2) Triangular-wave oscillator block

The triangular wave oscillator incorporates a timing capacitor and a timing resistor connected respectively to the CT terminal (pin 26) and RT terminal (pin 25) to generate triangular oscillation waveform CT (amplitude of 0.3 V to 0.8 V), CT1 (amplitude 1.1 V to 1.8 V in phase with CT), or CT2 (amplitude 1.1 V to 1.8 V in inverse phase with CT).

CT1 and CT2 are input to the PWM comparator in the IC.

#### (3) Error amplifier (Error Amp.) block

The error amplifier detects the DC/DC converter output voltage and outputs PWM control signals. It supports a wide range of in-phase input voltages from 0 V to " $V_{CC} - 1.8$  V" (channels 1 to 5), or 0 V to " $V_{CC} - 0.9$  V" (channel 6) allowing easy setting from the external power supply.

In addition, an arbitrary loop gain can be set by connecting a feedback resistor and capacitor from the output pin to inverted input pin of the error amplifier, enabling stable phase compensation to the system.

#### (4) Inverting amplifier (Inv Amp.) block

The inverting amplifier detects the DC/DC converter output voltage (as a negative voltage) and outputs a control signal to the error amp.

#### (5) PWM comparator (PWM Comp.) block

The PWM comparator is a voltage-to-pulse width converter for controlling the output duty depending on the input voltage.

Channels 1, 2, and 5 main sides, channel 3, 4, and 6 : The comparator keeps the output transistor on while the error amplifier output voltage and DTC voltage remain higher than the triangular wave voltage.

Channels 1, 2, and 5 synchronous rectification sides : The comparator keeps the output transistor on while the error amplifier output voltage remain lower than the triangular wave voltage.

#### (6) Output block

The output block on the main side and on the synchronous rectification side is both in the totem pole configuration, capable of driving an external P-channel MOS FET (channels 1, 2 main sides, channel 5 synchronous rectification side), NPN transistor (channel 6), and N-channel MOS FET (channels 3, 4, channel 5 main side, channels 1, 2 synchronous rectification sides).

## 2. Channel Control Function

Channels are turned on and off depending on the voltage levels at the CTL terminal (pin 20), CTL1, 2 terminal (pin 21), CTL3 terminal (pin 22), CTL4 terminal (pin 23), and CTL5 terminal (pin 24).

Channel On/Off Setting Conditions

Voltage level at CTL pin					Channel on/off state													
CTL	CTL1, 2	CTL3	CTL4	CTL5	Power/CH6	CH1, CH2	CH3	CH4	CH5									
L	×	×	×	×	OFF (Standby state)													
H	L	L	L	L	ON	OFF	OFF	OFF	OFF	OFF								
				H					ON	ON								
			H	H				L	L	ON	ON	OFF	OFF	OFF				
									H				ON	ON				
			H					L	L	L	ON	ON	OFF	OFF	OFF			
										H				ON	ON			
		H	H				L		L	ON				ON	ON	OFF	OFF	
									H							ON	ON	
		H		L			L		L	ON				ON	ON	OFF	OFF	
									H							ON	ON	
		H					H	L	L		ON	ON	ON			OFF	OFF	
									H							ON	ON	
	H	L	L			L		ON	ON							ON	OFF	OFF
						H											ON	ON
	H		H	L		L				ON				ON	ON		OFF	OFF
						H											ON	ON

× : Undefined

## 3. Protective Functions

### (1) Timer-latch short-circuit protection circuit

The short-circuit detection comparator in each channel detects the output voltage level and, if any channel output voltage falls below the short-circuit detection voltage, the timer circuits is actuated to start charging the external capacitor  $C_{SCP}$  connected to the CSCP terminal (pin 18).

When the capacitor voltage reaches about 0.70 V, the circuit is turned off the output transistor and sets the dead time to 100 %.

To reset the actuated protection circuit, turn the power supply on back. (See “SETTING TIME CONSTANT FOR TIMER-LATCH SHORT-CIRCUIT PROTECTION CIRCUIT”.)

### (2) Undervoltage lockout protection circuit

The transient state or a momentary decrease in supply voltage, which occurs when the power supply is turned on, may cause the IC to malfunction, resulting in breakdown or degradation of the system. To prevent such malfunctions, the undervoltage lockout protection circuit detects a decrease in internal reference voltage with respect to the power supply voltage, turns off the output transistor, and sets the dead time to 100% while holding the CSCP terminal (pin 18) at the “L” level.

The circuit restores the output transistor to normal when the supply voltage reaches the threshold voltage of the undervoltage lockout protection circuit.

### (3) Output switch control circuit

When the power is turned on, this circuit prevents reactive current flow to external step-up circuits on CH5 and CH6. When the SWIN terminal (pin 2) is a state at “H” level after releasing UVLO and the C+IN6 terminal (pin5) voltage goes above 0.9 V (Typ.), the SWOUT terminal (pin 1) becomes “L” level. External P-ch MOS FET is turned on at this time and the output voltage is generated.

## 4. Soft Start Operation

### 1. Description

- When the CTL, CTL1,2, CTL3, CTL4, and CTL5 terminals are driven high ("H" level) at the same time

The capacitor (C+IN6) connected to the C+IN6 terminal (pin 5) starts charging. When the C+IN6 terminal voltage falls below 0.9 V (Typ.), the capacitor (Cs) connected to the CS terminal (pin 15) starts charging and the error amp. provides a soft start by comparing the CH1 to CH5 output voltage to the voltage at the CS terminal.

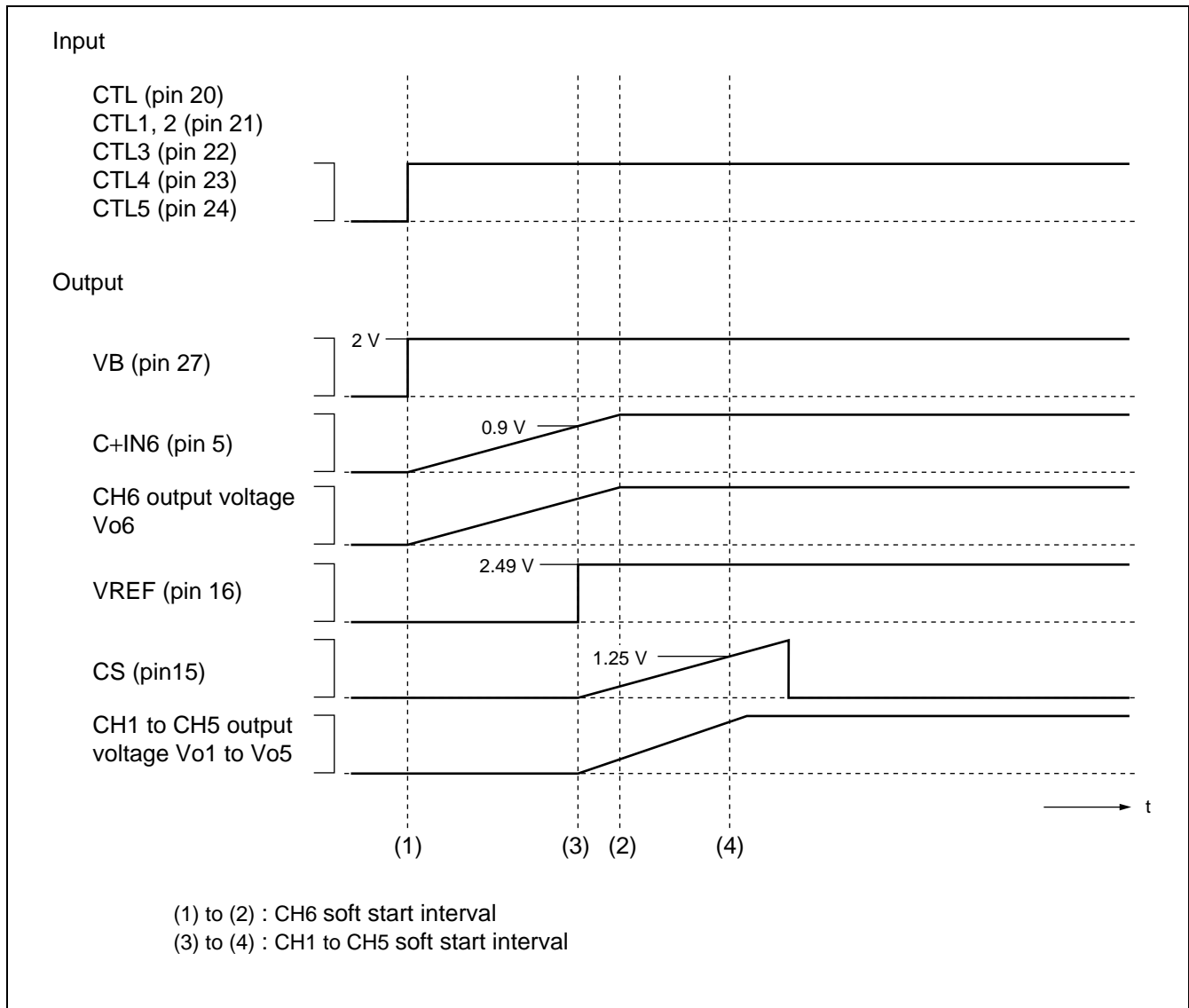

# MB3883

- After a CH6 soft start, when the CTL1, 2, CTL3, CTL4, and CTL5 terminals are driven high

The capacitor (Cs) connected to the CS terminal (pin 15) starts charging and the error amp provides a soft start by comparing the CH1 to CH5 output voltage to the voltage at the CS terminal.

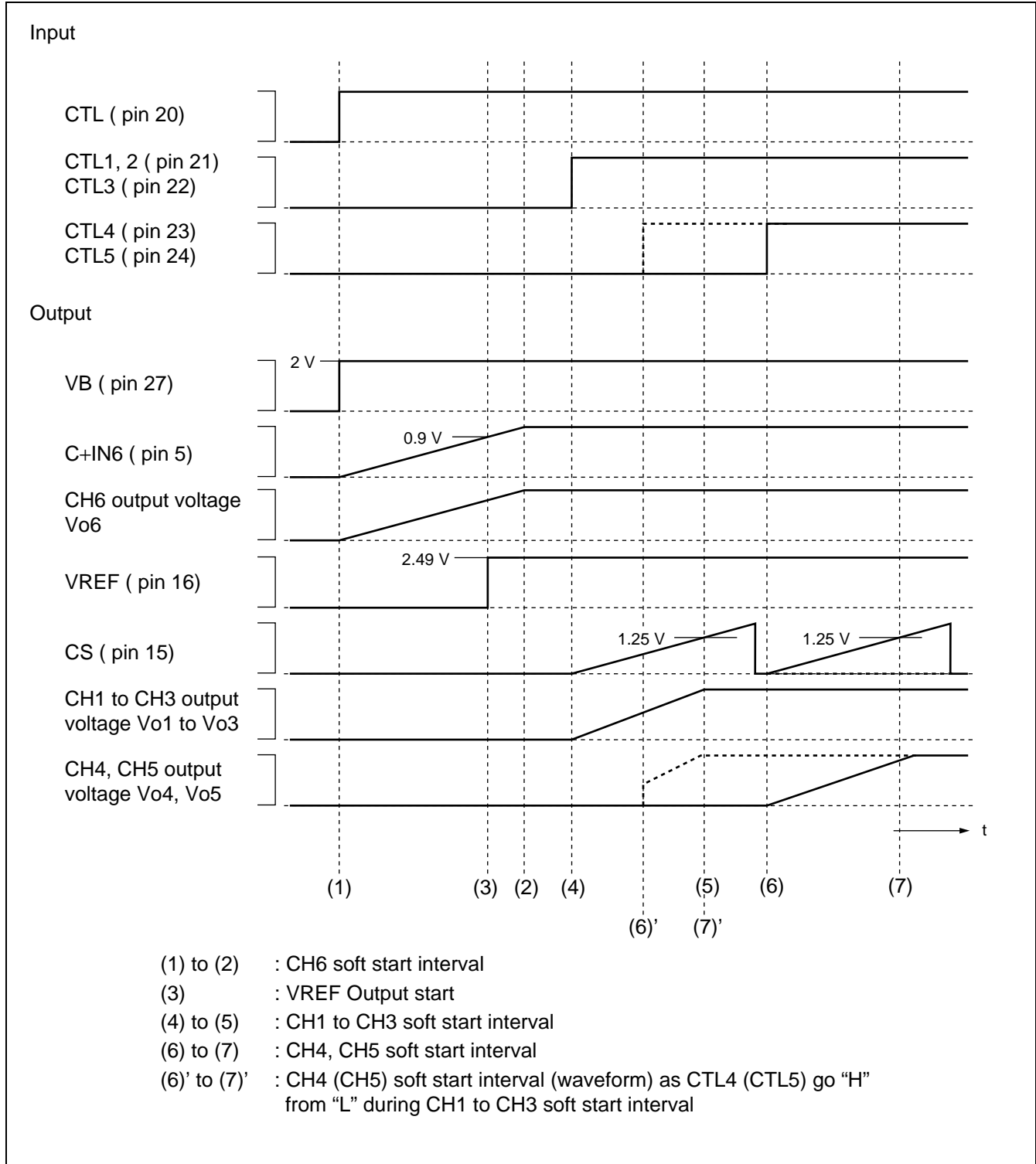

Note : Each of the terminals CTL1,2, CTL3, CTL4, and CTL5 can be switched on or off independently. When any of these CTL terminals is switched on, a soft start operation is provided as shown in the above timing chart.

## 2. Soft Start Settings

- CH6 soft start time

The soft start operation is determined by the capacitor (C+IN6) connected to the C+IN6 terminal (pin 5). The soft start time depends on the input voltage and load current.

CH6 soft start time

$$t_s (s) = - \frac{C_{+IN6} (F) \times 37.5 (k\Omega) \times 62.5 (k\Omega)}{100 (k\Omega)} \ln \left( 1 - \frac{V_{C+IN6} (V)}{1.26 (V)} \right)$$

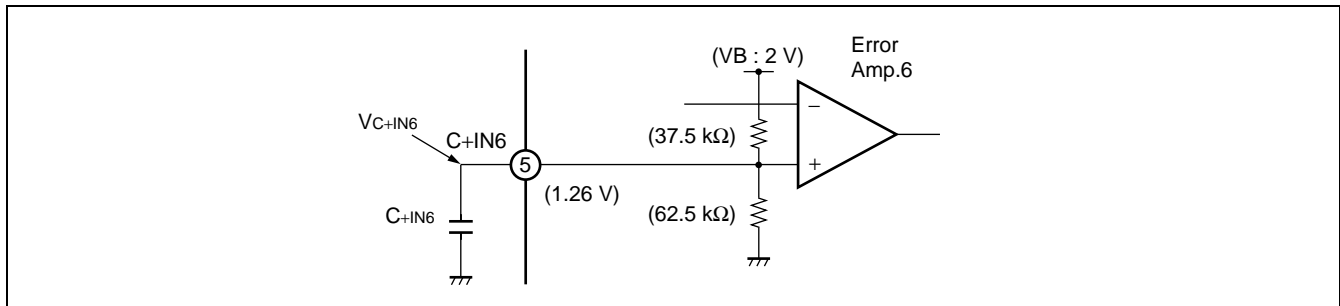

**CH6 soft start equivalent circuit**

Example: The soft start time until CH6 output voltage reaches 95% of the set voltage is determined as follows:

$$t_s (s) \doteq 0.07 \times C_{+IN6} (\mu F)$$

- CH1 to CH5 soft start time

CH1 to CH5 soft start time

$$t_s (s) \doteq 1.25 \times C_s (\mu F)$$

Note : The short-circuit detection function remains working during soft start operation on channels 1 through 5.

## ■ SETTING THE TRIANGULAR OSCILLATOR FREQUENCY

The triangular oscillator frequency is determined by the timing capacitor (C<sub>T</sub>) connected to the CT terminal (pin 26), and the timing resistor (R<sub>T</sub>) connected to the RT terminal (pin 25).

Triangular oscillator frequency

$$f_{osc} (kHz) \doteq \frac{900000}{C_T (pF) \bullet R_T (k\Omega)}$$

## ■ SETTING THE OUTPUT VOLTAGE

- CH1 to CH3, CH5

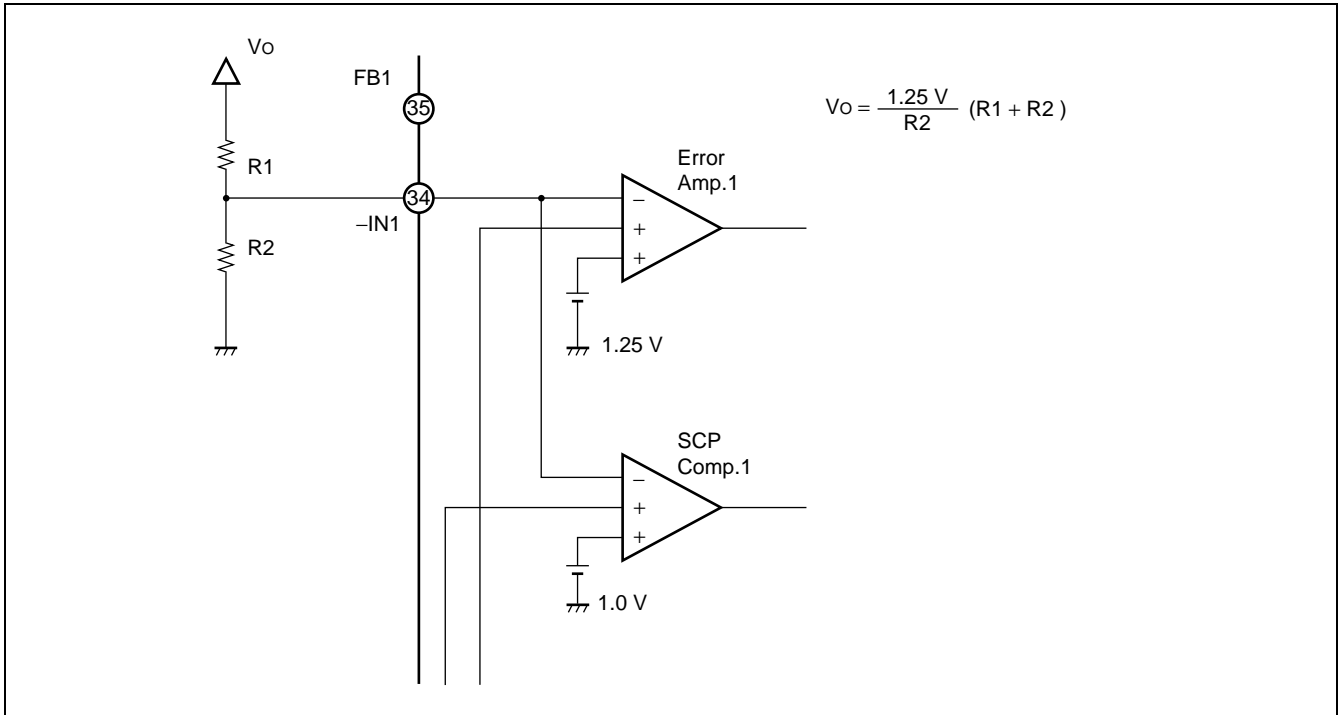

- CH4

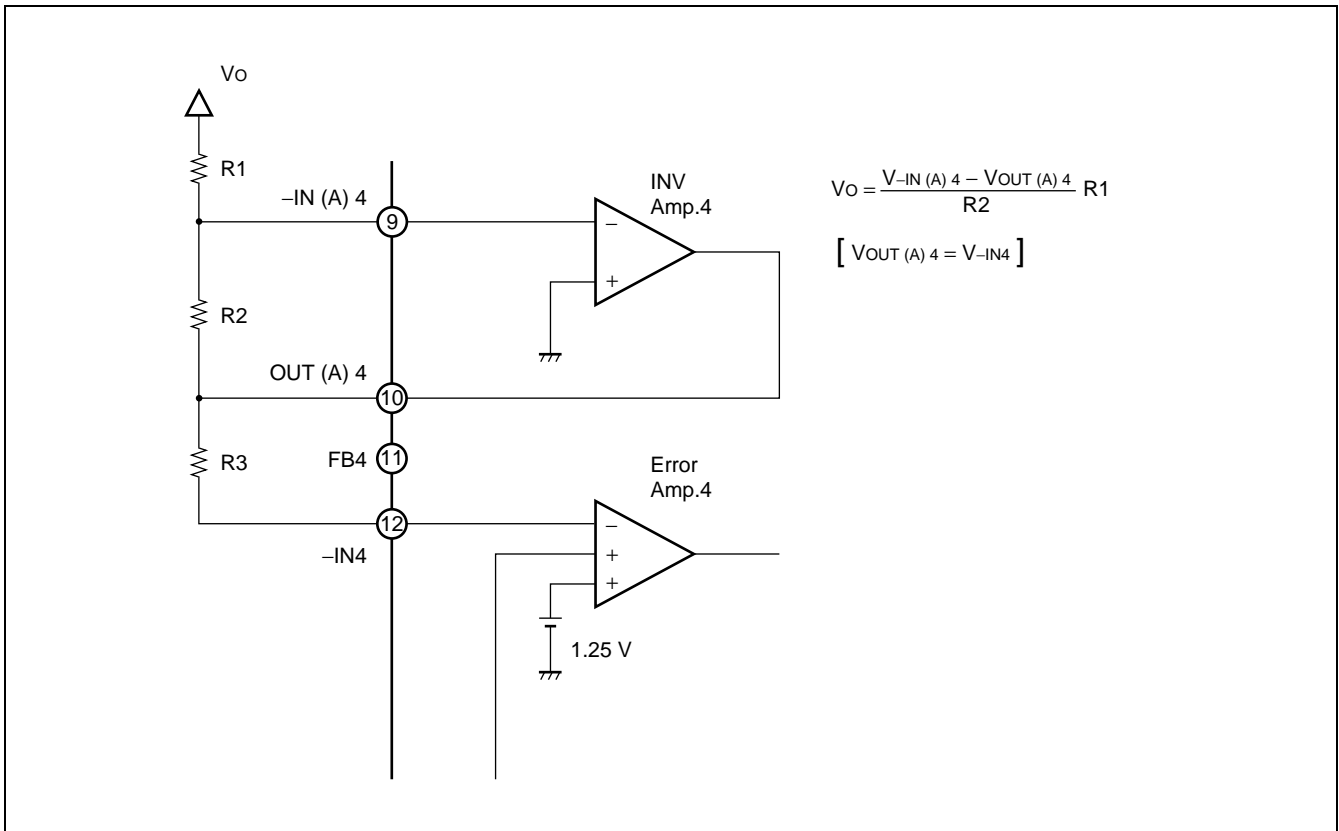

• CH6

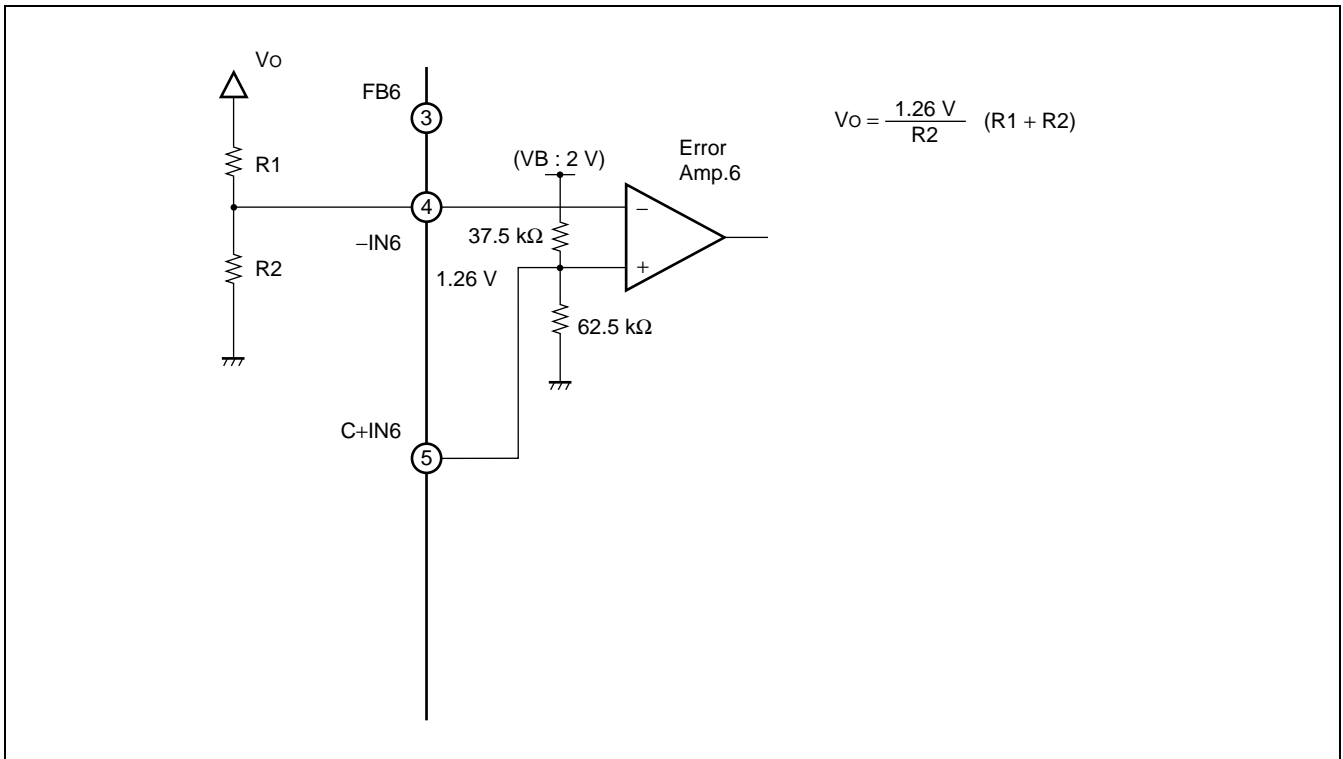

## ■ SETTING THE OUTPUT CURRENT

The output circuit (drive 6) is structured as illustrated below (in the output circuit diagram). As found in “Output Current Waveform” below, the source current value of the output current waveform has a constant current setting.

Note that the source current is set by the following equation:

- Output source current =  $(V_B / R_B) \times 80$  (A)

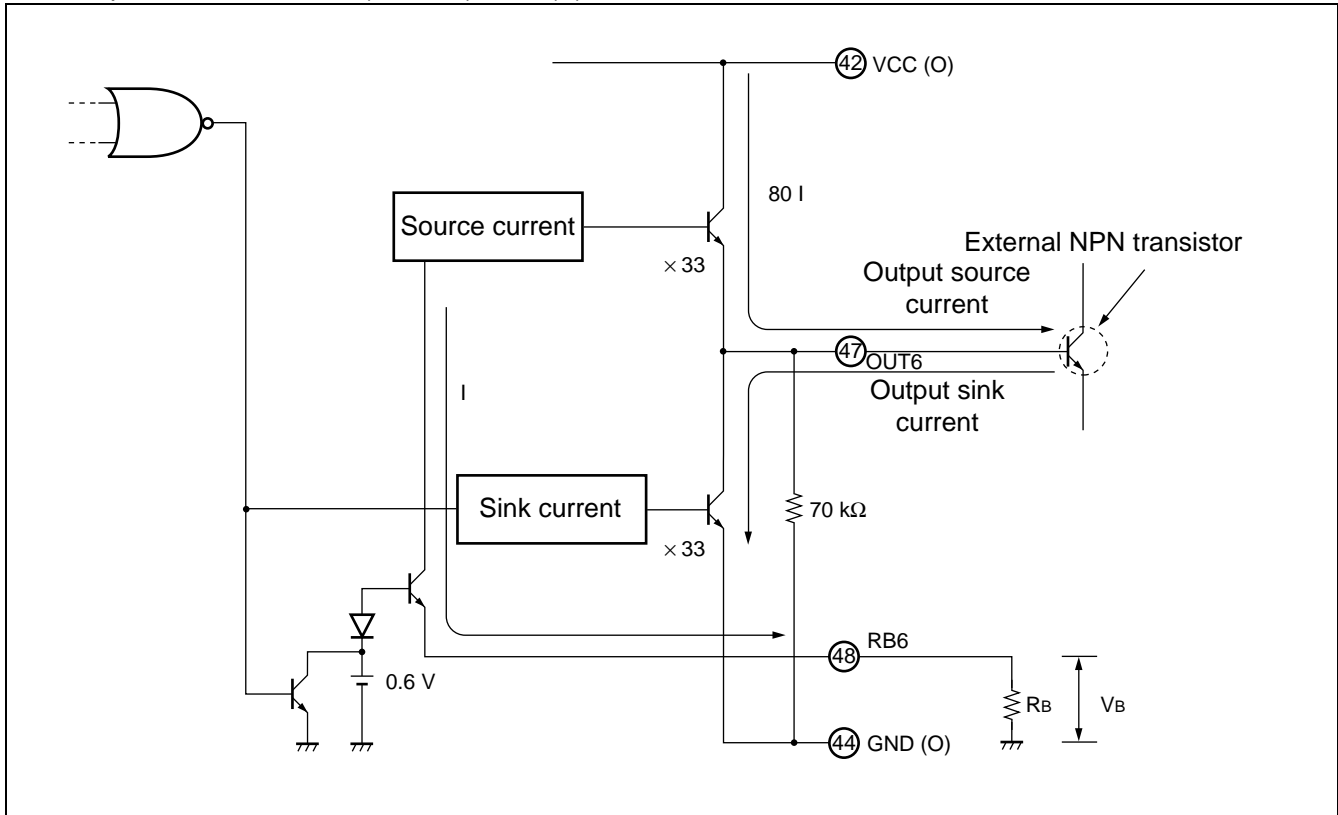

In the output circuit diagram

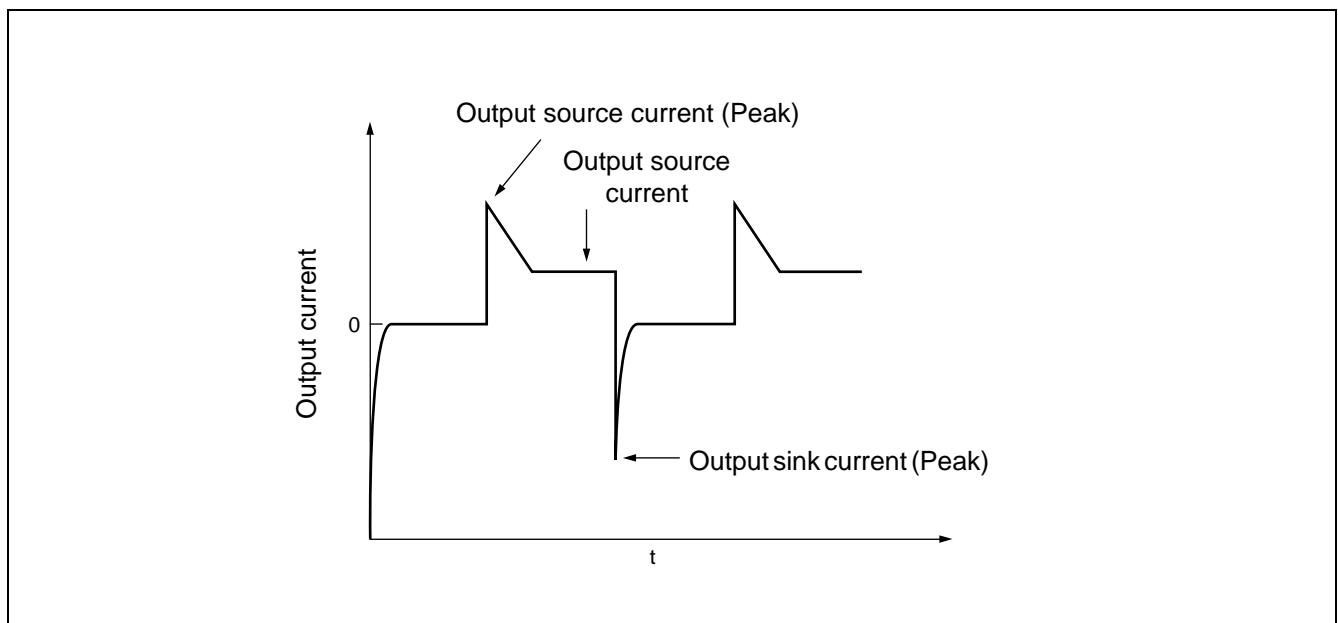

Output current waveform

## SETTING TIME CONSTANT FOR TIMER-LATCH SHORT-CIRCUIT PROTECTION CIRCUIT

The short detection comparator (SCP comparator) in each channel monitors the output voltage. While the switching regulator load conditions are stable on all channels, the LOG\_SCP output remains at “H” level, transistor Q1 is turned on, and the CSCP terminal (pin 18) is held at “L” level. If the load condition on a channel changes rapidly due to a short of the load, causing the output voltage to drop, the output of the short detection comparator on that channel goes to “H” level. This causes transistor Q1 to be turned off and the external short protection capacitor C<sub>SCP</sub> connected to the CSCP terminal to be charged at 1.0 μA.

Short detection time (t<sub>PE</sub>)

$$t_{PE} (s) \approx 0.70 \times C_{SCP} (\mu F)$$

When the capacitor C<sub>SCP</sub> is charged to the threshold voltage (V<sub>TH</sub> ≈ 0.70 V), the latch is set and the external FET is turned off (dead time is set to 100%). At this point, the latch input is closed and the CSCP terminal is held at “L” level.

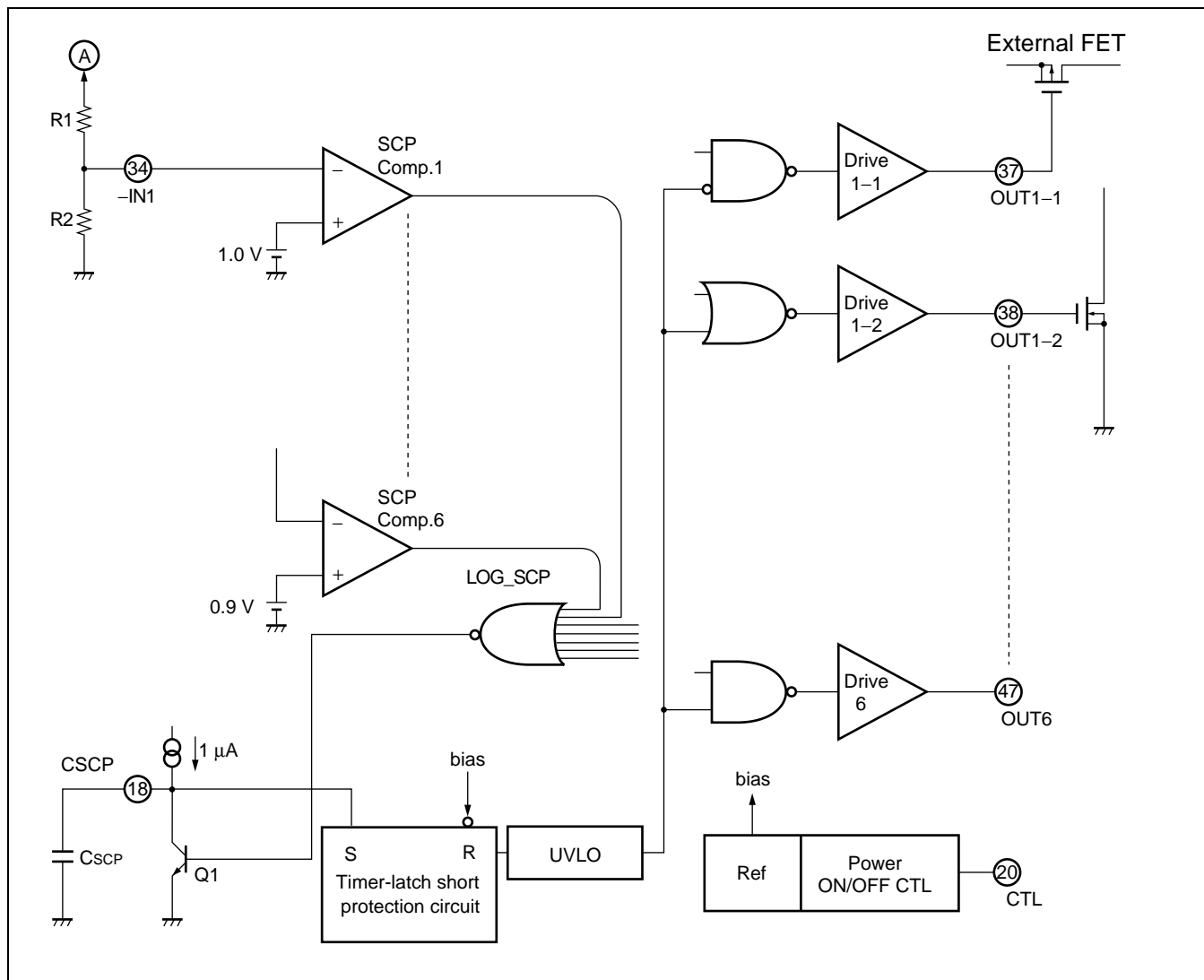

Timer-latch short circuit protection circuit

## ■ TREATMENT WITHOUT USING CSCP

When not using the timer-latch short protection circuit, connect the CSCP terminal (pin 18) to GND with the shortest distance.

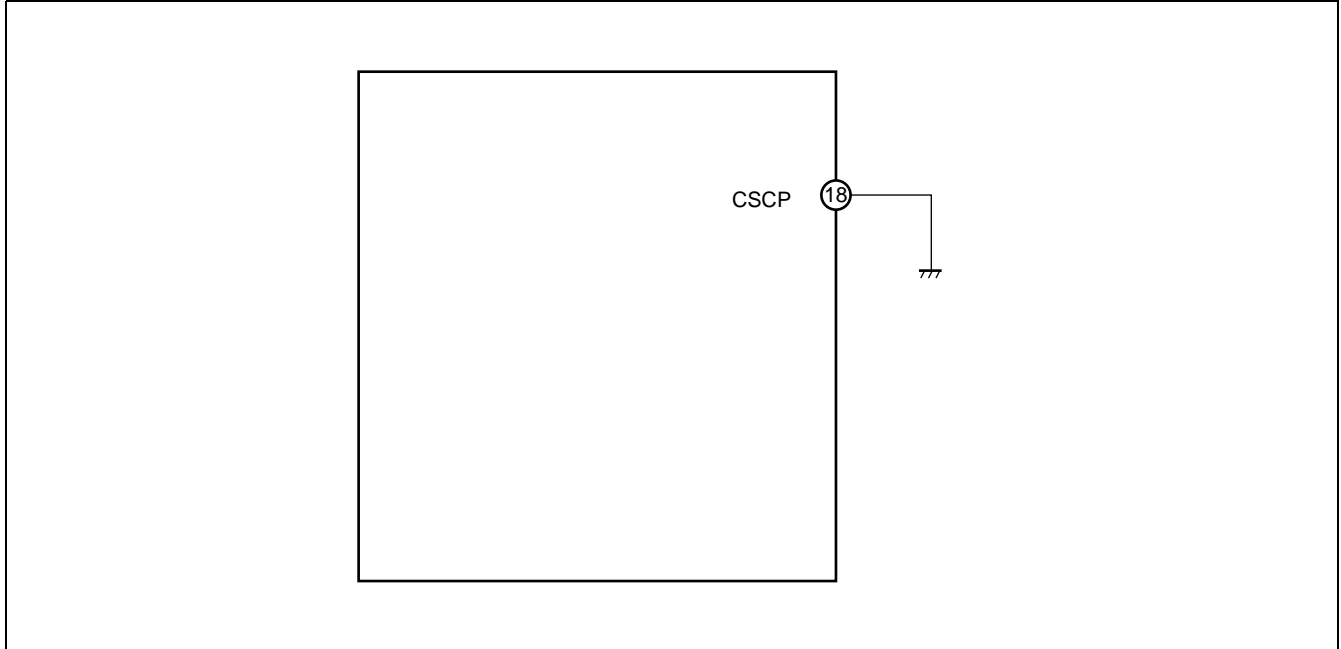

Treatment without using CSCP

## ■ OPERATING WITHOUT THE SOFT START FUNCTION

To disable the CH1 to CH5 soft start function, leave the CS terminal (pin 15) open.  
To disable the CH6 soft start function, leave the C+IN6 terminal (pin 5) open.

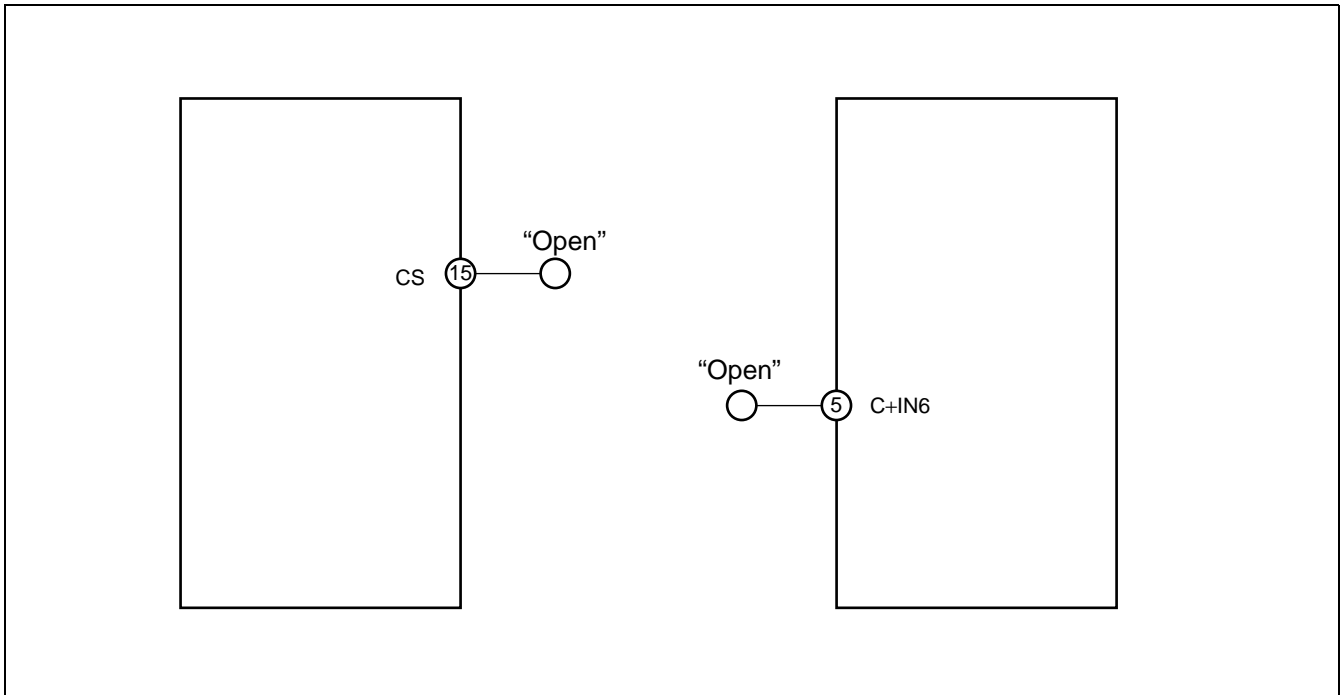

When no soft start time is set

## ■ SETTING THE DEAD TIME

When the device is set for step-up inverted output based on the step-up or step-up/down Zeta method or flyback method, the FB pin voltage may reach and exceed the rectangular wave voltage due to load fluctuation. If this is the case, the output transistor is fixed to a full-ON state (ON duty = 100 %). To prevent this, set the maximum duty of the output transistor. To set it, set the voltage at the DTC1 terminal (pin 36) by applying a resistive voltage divider to the VREF voltage as shown below.

When the voltage at the DTC1 terminal (pin 36) is higher than the triangular wave voltage (CT1), the output transistor is turned on. The maximum duty calculation formula assuming that triangular wave amplitude = 0.7 V and triangular wave minimum voltage = 1.1 V is given below. (Same to other channels.)

$$\text{DUTY (ON) max} = \frac{V_{dt} - 1.1 \text{ V}}{0.7 \text{ V}} \times 100 (\%), \quad V_{dt} = \frac{R_b}{R_a + R_b} \times V_{REF}$$

When the DTC1 terminal is not used, connect it directly to the VREF terminal (pin 16) as shown below (when no dead time is set). (Same to other channels.)

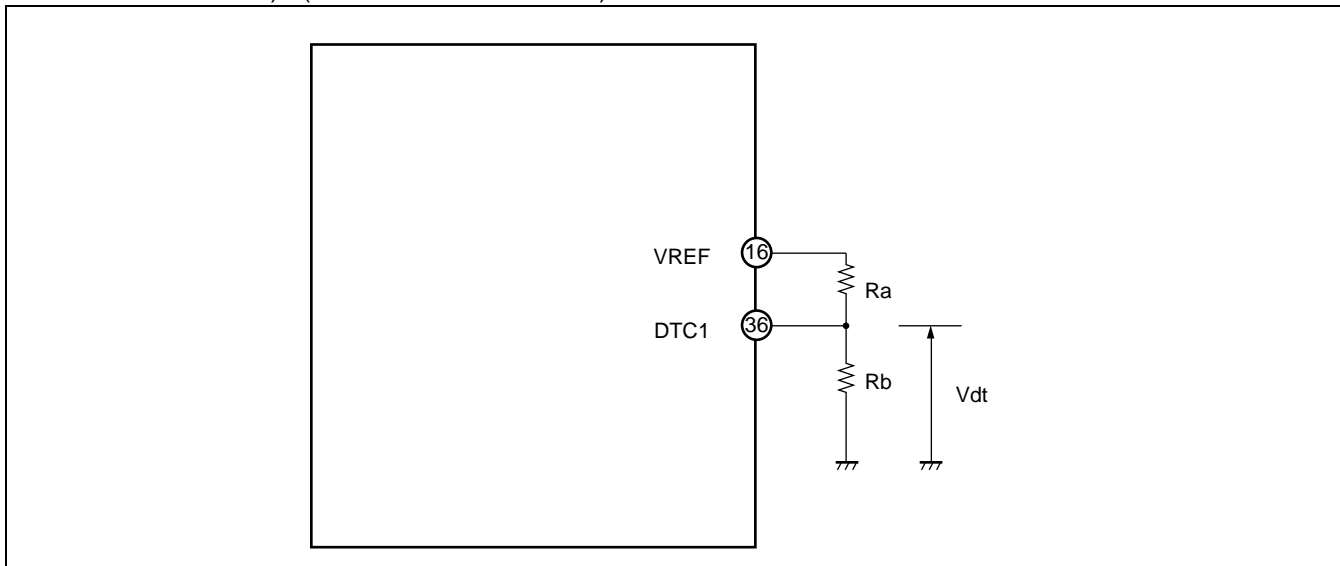

When using DTC to set dead time (Same to other channels.) ( CH1)

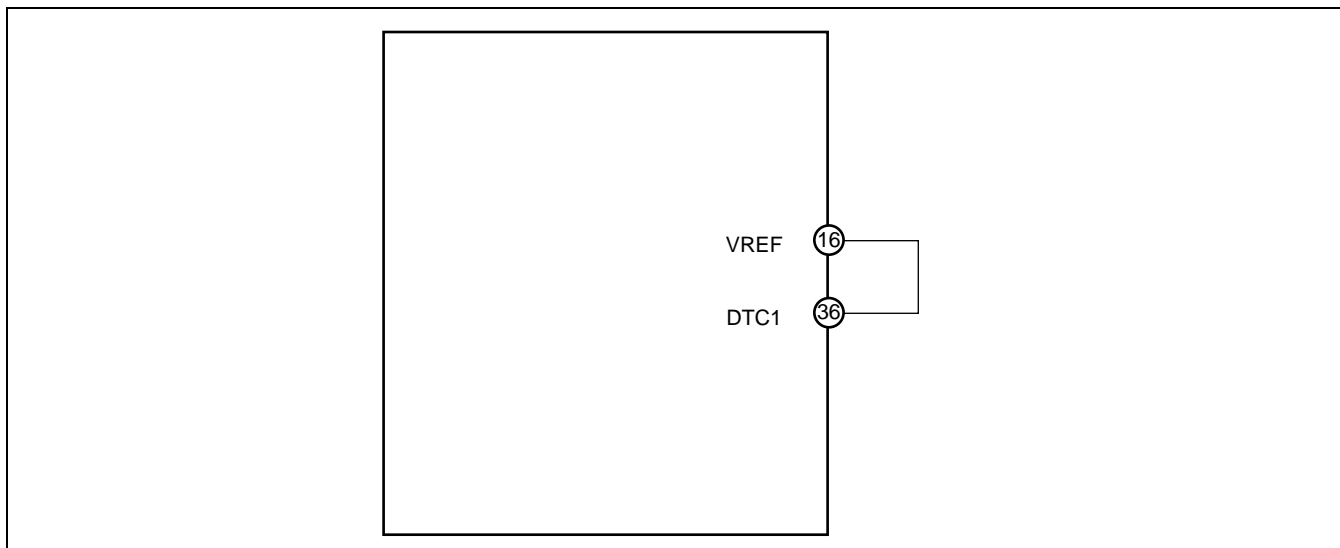

When no dead time is set ( Same to other channels.) ( CH 1)

## ■ TREATMENT WITHOUT USING CH4 INV Amp.

When not using the CH4 INV Amp., connect the -IN(A)4 terminal (pin 9) to the OUT(A)4 terminal (pin 10) with the shortest distance.

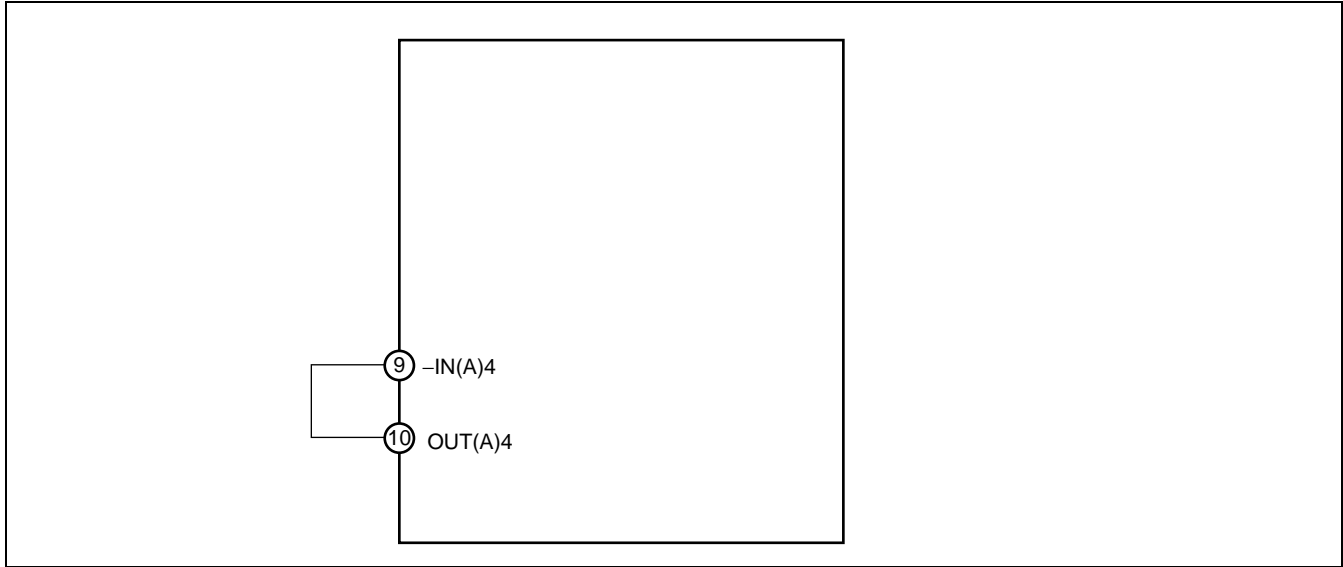

Treatment without using CH4 INV Amp.

## APPLICATION EXAMPLE

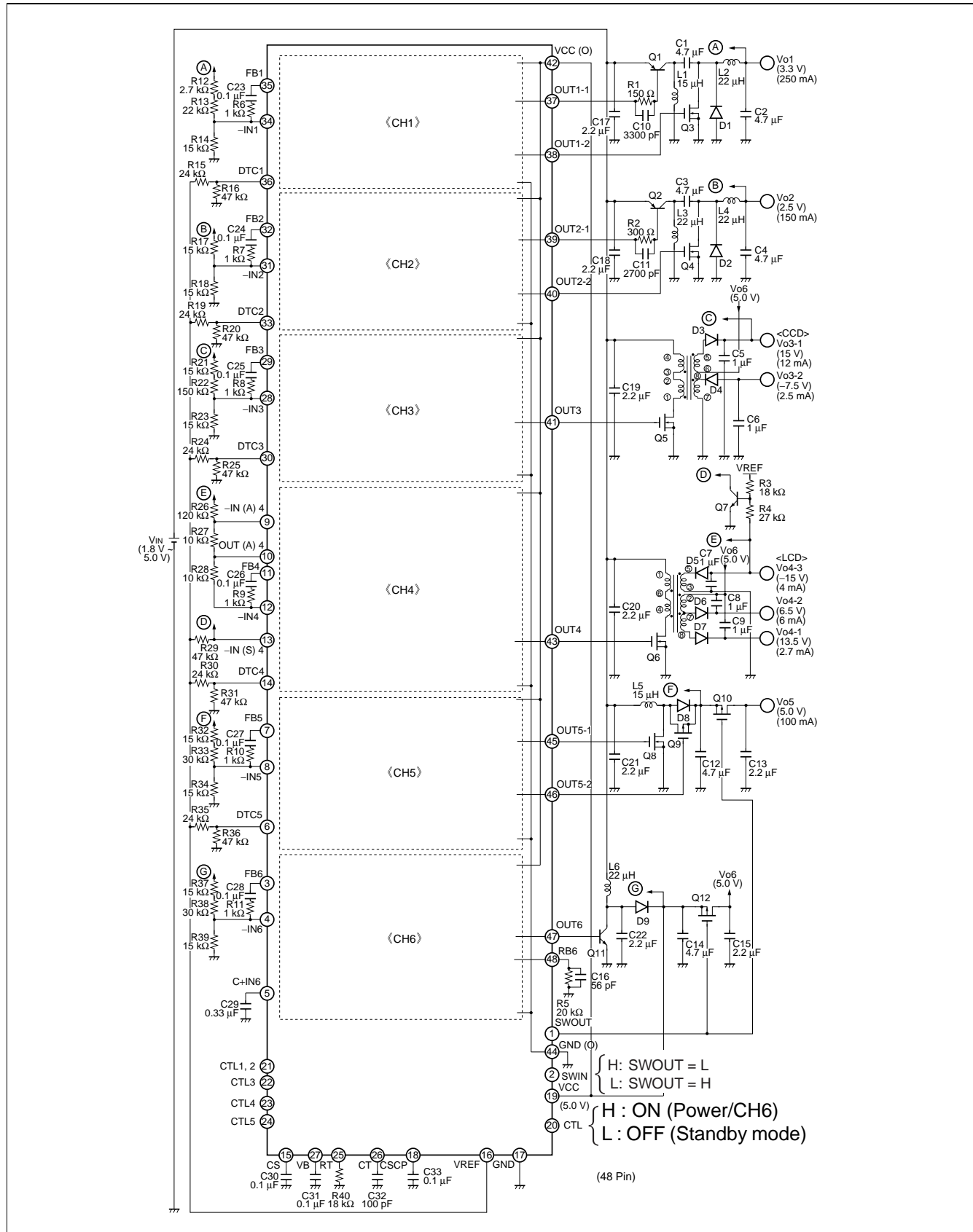

# MB3883

## • Application example (Expansion1/2)

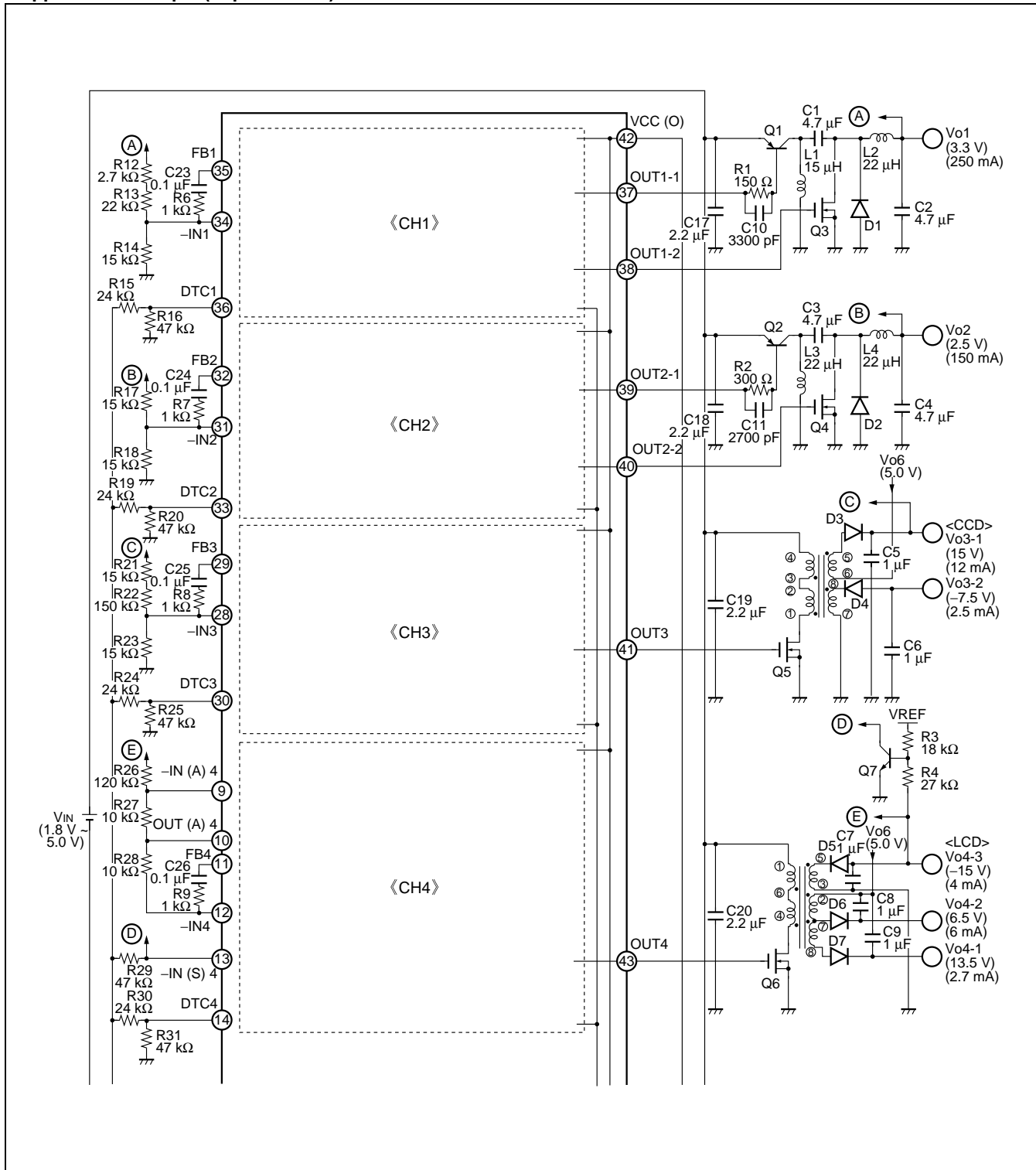

• Application example (Expansion 2/2)

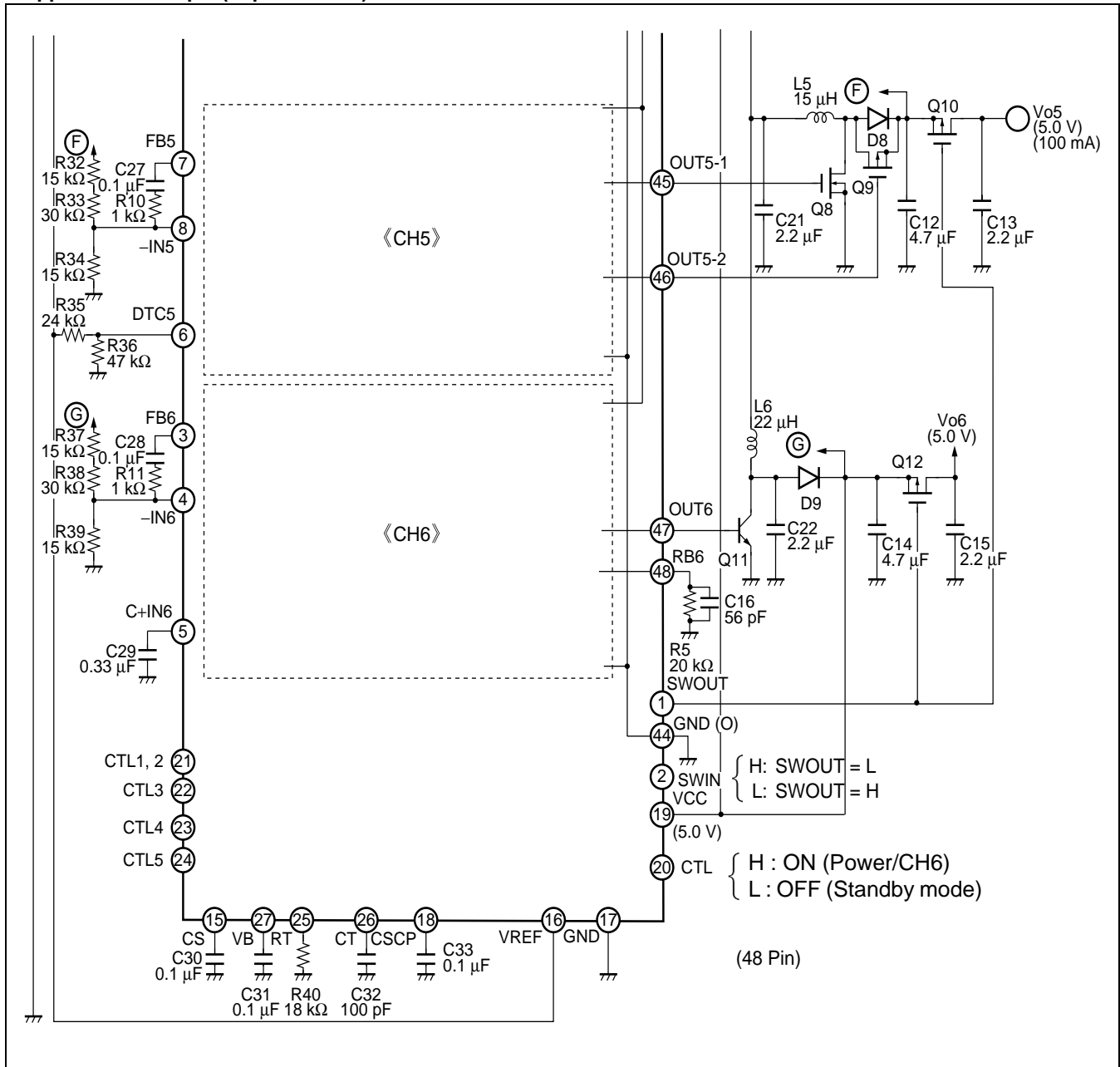



## REFERENCE DATA

Conversion efficiency vs. load current  
(CH1 : Zeta method with synchronous rectification)

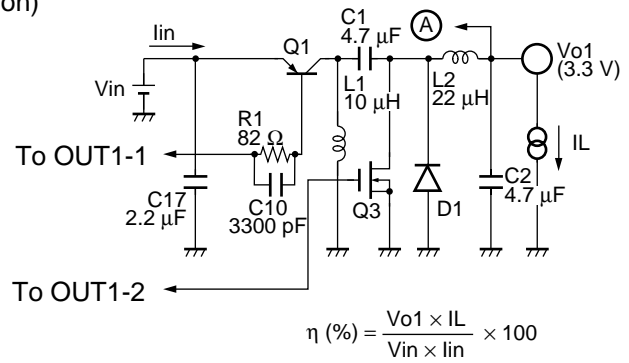
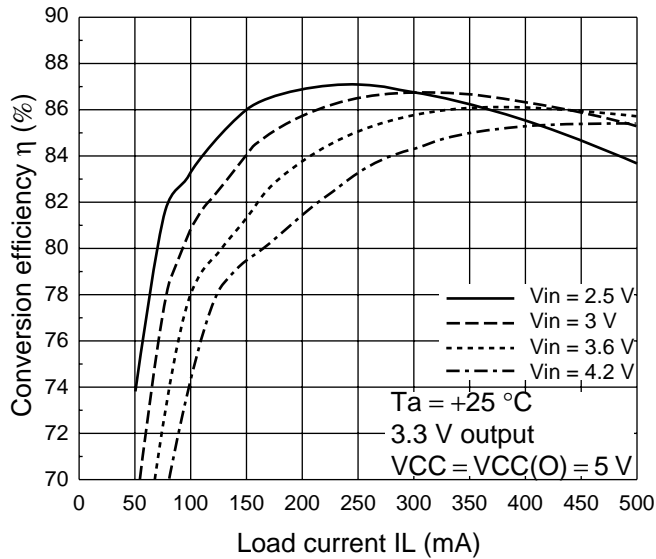

Conversion efficiency vs. load current  
(CH2 : Zeta method with synchronous rectification)

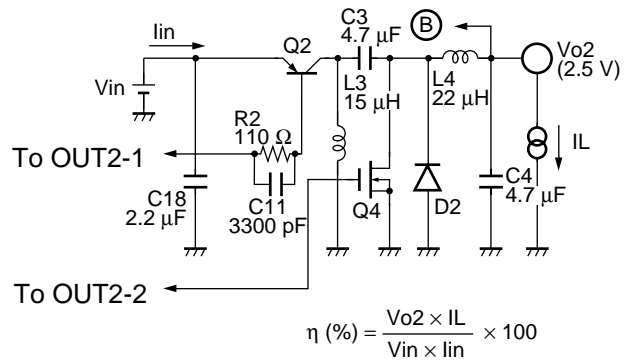
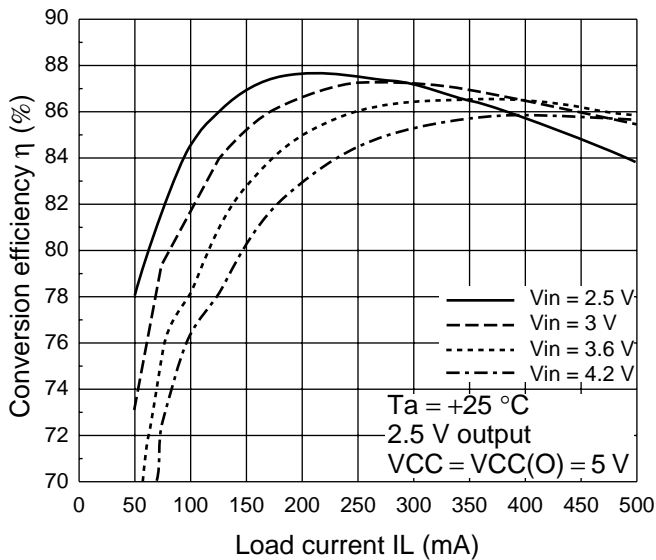

Note : The above application uses a constant of Vin=2.5 V, with settings made at maximum load.

(Continued)

(Continued)

Conversion efficiency vs. load current  
(CH5 : Up conversion method with synchronous rectification)

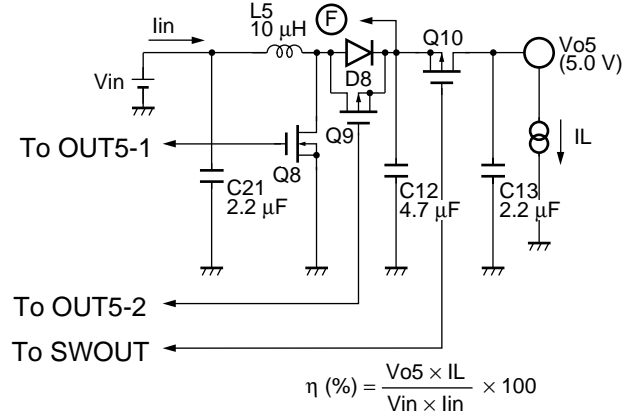
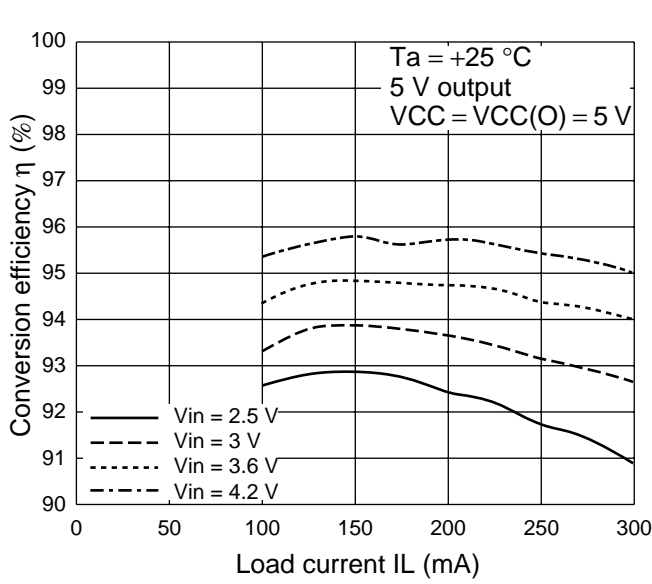

Note : The above application uses a constant of  $V_{in}=2.5\text{ V}$ , with settings made at maximum load.

## ■ USAGE PRECAUTION

- Printed circuit board ground lines should be set up with consideration for common impedance.
- Take appropriate static electricity measures.
  - Containers for semiconductor materials should have anti-static protection or be made of conductive material.
  - After mounting, printed circuit boards should be stored and shipped in conductive bags or containers.
  - Work platforms, tools, and instruments should be properly grounded.
  - Working personnel should be grounded with resistance of 250 kΩ to 1 MΩ between body and ground.
- Do not apply negative voltages.
 

The use of negative voltages below  $-0.3\text{ V}$  may create parasitic transistors on LSI lines, which can cause abnormal operation.

## ■ ORDERING INFORMATION

Part number	Package	Remarks
MB3883PFV	48-pin plastic LQFP (FPT-48P-M05)	
MB3883PV	48-pad plastic BCC (LCC-48P-M02)	

# MB3883

## PACKAGE DIMENSIONS

48-pin plastic LQFP  
(FPT-48P-M05)

Note 1) \* : These dimensions include resin protrusion.  
Note 2) Pins width and pins thickness include plating thickness.

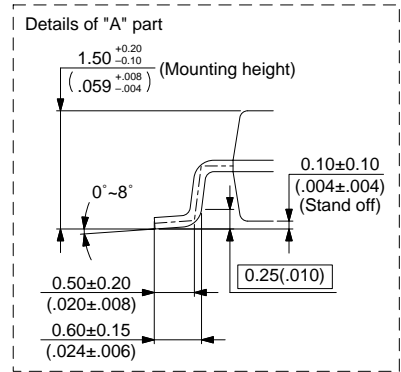
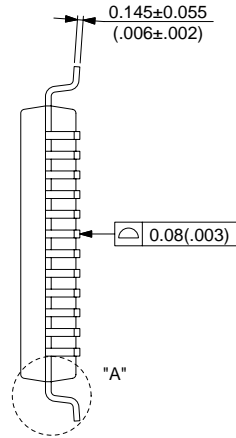
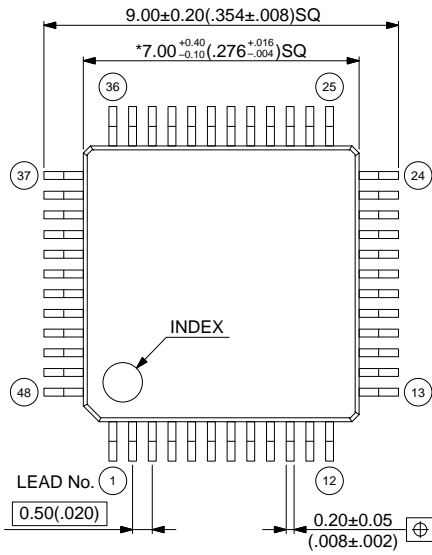

© 2002 FUJITSU LIMITED F48013S-c-5-9

Dimensions in mm (inches)

(Continued)



## FUJITSU LIMITED

All Rights Reserved.

The contents of this document are subject to change without notice. Customers are advised to consult with FUJITSU sales representatives before ordering.

The information and circuit diagrams in this document are presented as examples of semiconductor device applications, and are not intended to be incorporated in devices for actual use. Also, FUJITSU is unable to assume responsibility for infringement of any patent rights or other rights of third parties arising from the use of this information or circuit diagrams.

The products described in this document are designed, developed and manufactured as contemplated for general use, including without limitation, ordinary industrial use, general office use, personal use, and household use, but are not designed, developed and manufactured as contemplated (1) for use accompanying fatal risks or dangers that, unless extremely high safety is secured, could have a serious effect to the public, and could lead directly to death, personal injury, severe physical damage or other loss (i.e., nuclear reaction control in nuclear facility, aircraft flight control, air traffic control, mass transport control, medical life support system, missile launch control in weapon system), or (2) for use requiring extremely high reliability (i.e., submersible repeater and artificial satellite).

Please note that Fujitsu will not be liable against you and/or any third party for any claims or damages arising in connection with above-mentioned uses of the products.

Any semiconductor devices have an inherent chance of failure. You must protect against injury, damage or loss from such failures by incorporating safety design measures into your facility and equipment such as redundancy, fire protection, and prevention of over-current levels and other abnormal operating conditions.

If any products described in this document represent goods or technologies subject to certain restrictions on export under the Foreign Exchange and Foreign Trade Law of Japan, the prior authorization by Japanese government will be required for export of those products from Japan.