

ASSP

# Fractional-N PLL Frequency Synthesizer

## MB15F86UL

### DESCRIPTION

The Fujitsu MB15F86UL is Fractional-N Phase Locked Loop (PLL) frequency synthesizer with fast lock up function.

The Fractional-N PLL operating up to 2500\* MHz and the integer PLL operating up to 600 MHz are integrated on one chip.

The MB15F86UL is used, as charge pump which is well-balanced output current with 1.5 mA and 6 mA selectable by serial data, direct power save control and digital lock detector. In addition, the MB15F86UL adopts a new architecture to achieve fast lock.

The new package (Thin Bump Chip Carrier20) decreases a mount area of MB15F86UL more than 30% comparing with the former B.C.C.16 (for dual PLL, MB15F03SL) .

The MB15F86UL is ideally suited for wireless mobile communications, such as TDMA or CDMA.

### FEATURES

- High frequency operation : RF synthesizer : 2500\* MHz Max  
: IF synthesizer : 600 MHz Max
- Low power supply voltage :  $V_{CC} = 2.7 \text{ V to } 3.6 \text{ V}$
- Ultra Low power supply current :  $I_{CC} = 5.8 \text{ mA Typ}$  ( $V_{CC} = V_p = 3.0 \text{ V}$ ,  $T_a = +25 \text{ }^\circ\text{C}$ ,  $SW = 0$  in IF and RF locking state)

(Continued)

### PACKAGES

20-pin, Plastic TSSOP

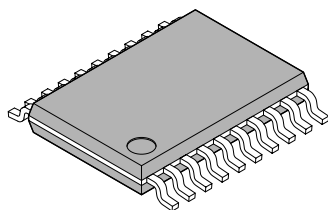

(FPT-20P-M06)

20-pad, Plastic BCC

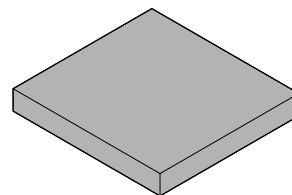

(LCC-20P-M05)

# MB15F86UL

(Continued)

- Direct power saving function : Power supply current in power saving mode  
Typ 0.1  $\mu$ A ( $V_{CC} = V_p = 3.0$  V,  $T_a = +25$  °C) , Max 10  $\mu$ A ( $V_{CC} = V_p = 3.0$  V)
- Fractional function : modulo 3 to 16 programmable (implemented in RF-PLL)
- Dual modulus prescaler : 2500\* MHz prescaler (16/17 or 32/33) /600 MHz prescaler (8/9 or 16/17)
- Serial input 14-bit programmable reference divider : R = (RF section 8 bit) 3 to 255, (IF section 14 bit) 3 to 16, 383
- Serial input programmable divider consisting of :
  - RF section- Binary 5-bit swallow counter : 0 to 31
    - Binary 10-bit programmable counter : 18 to 1,023
    - Binary 4-bit fractional counter numerator : 0 to 15
  - IF section - Binary 4-bit swallow counter : 0 to 15
    - Binary 11-bit programmable counter : 3 to 2,047
- On-chip phase comparator for fast lock and low noise
- Operating temperature :  $T_a = -40$  °C to  $+85$  °C
- Small package Bump Chip Carrier.0 (3.4 mm  $\times$  3.6 mm  $\times$  0.6 mm)

\* : In case of  $f_{max} = 2500$  MHz, the following conditions must be fulfilled. Except for it,  $f_{max}$  is up to 2000 MHz.  
 Prescaler ratio = 32 ( $N > P$ ) at all divide ratio of used operating frequency.  
 Refer to a calculation formula of divide ratio.  $f_{V_{CORF}} = (P \times N + A + F/Q) \times f_{osc}/R$

## PIN ASSIGNMENTS

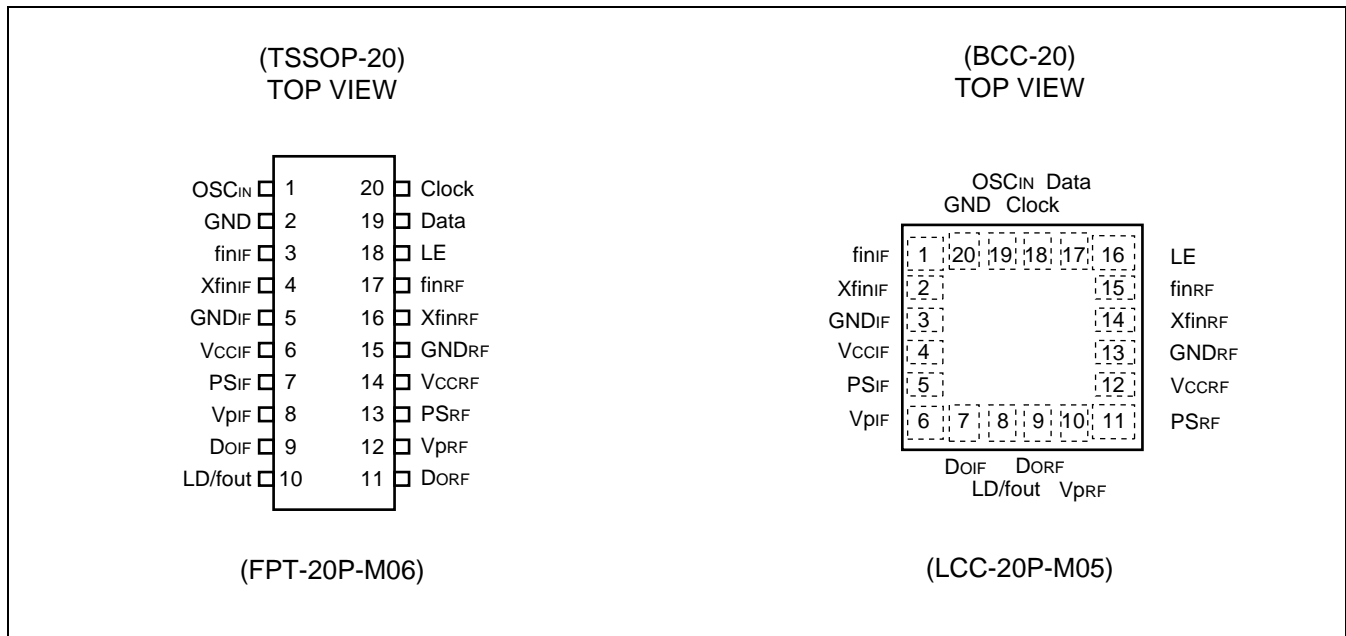

## ■ PIN DESCRIPTION

Pin no.		Pin name	I/O	Descriptions
TSSOP	BCC			
1	19	OSC <sub>IN</sub>	I	The programmable reference divider input pin. TCXO should be connected with an AC coupling capacitor.
2	20	GND	—	Ground pin for OSC input buffer and the shift register circuit.
3	1	fin <sub>IF</sub>	I	Prescaler input pin for the IF-PLL. Connection to an external VCO should be AC coupling.
4	2	Xfin <sub>IF</sub>	I	Prescaler complimentary input pin for the IF-PLL section. This pin should be grounded via a capacitor.
5	3	GND <sub>IF</sub>	—	Ground pin for the IF-PLL section.
6	4	V <sub>CCIF</sub>	—	Power supply voltage input pin for the IF-PLL section (except for the charge pump circuit) , the shift register and the oscillator input buffer. When power is OFF, latched data of IF-PLL is lost.
7	5	PS <sub>IF</sub>	I	Power saving mode control signal pin for the IF-PLL section. This pin must be set at “L” when the power supply is started up. (Open is prohibited.) PS <sub>IF</sub> = “H”; Normal mode / PS <sub>IF</sub> = “L”; Power saving mode
8	6	V <sub>pIF</sub>	—	Power supply voltage input pin for the IF-PLL charge pump.
9	7	DO <sub>IF</sub>	O	Charge pump output pin for the IF-PLL section. Phase characteristics of the phase detector can be reversed by FC-bit.
10	8	LD/fout	O	Look detect signal output (LD) /phase comparator monitoring output (fout) pins. The output signal is selected by an LDS bit in a serial data. LDS bit = “H”; outputs fout signal / LDS bit = “L”; outputs LD signal
11	9	DO <sub>RF</sub>	O	Charge pump output pin for the RF-PLL section. Phase characteristics of the phase detector can be reversed by FC-bit.
12	10	V <sub>pRF</sub>	—	Power supply voltage input pin for the RF-PLL charge pump.
13	11	PS <sub>RF</sub>	I	Power saving mode control pin for the RF-PLL section. This pin must be set at “L” when the power supply is started up. (Open is prohibited. ) PS <sub>RF</sub> = “H”; Normal mode / PS <sub>RF</sub> = “L”; Power saving mode
14	12	V <sub>CCR<sub>RF</sub></sub>	—	Power supply voltage input pin for the RF-PLL section (except for the charge pump circuit) .
15	13	GND <sub>RF</sub>	—	Ground pin for the RF-PLL section.
16	14	Xfin <sub>RF</sub>	I	Prescaler complimentary input pin for the RF-PLL section. This pin should be grounded via a capacitor.
17	15	fin <sub>RF</sub>	I	Prescaler input pin for the RF-PLL. Connection to an external VCO should be AC coupling.
18	16	LE	I	Load enable signal input pin (with the schmitt trigger circuit) . On a rising edge of load enable, data in the shift register is transferred to the corresponding latch according to the control bit in a serial data.
19	17	Data	I	Serial data input pin (with the schmitt trigger circuit) . A data is transferred to the corresponding latch (IF-ref counter, IF-prog. counter, RF-ref. counter, RF-prog. counter) according to the control bit in a serial data.
20	18	Clock	I	Clock input pin for the 23-bit shift register (with the schmitt trigger circuit) . One bit data is shifted into the shift register on a rising edge of the clock.

# MB15F86UL

## ■ BLOCK DIAGRAM

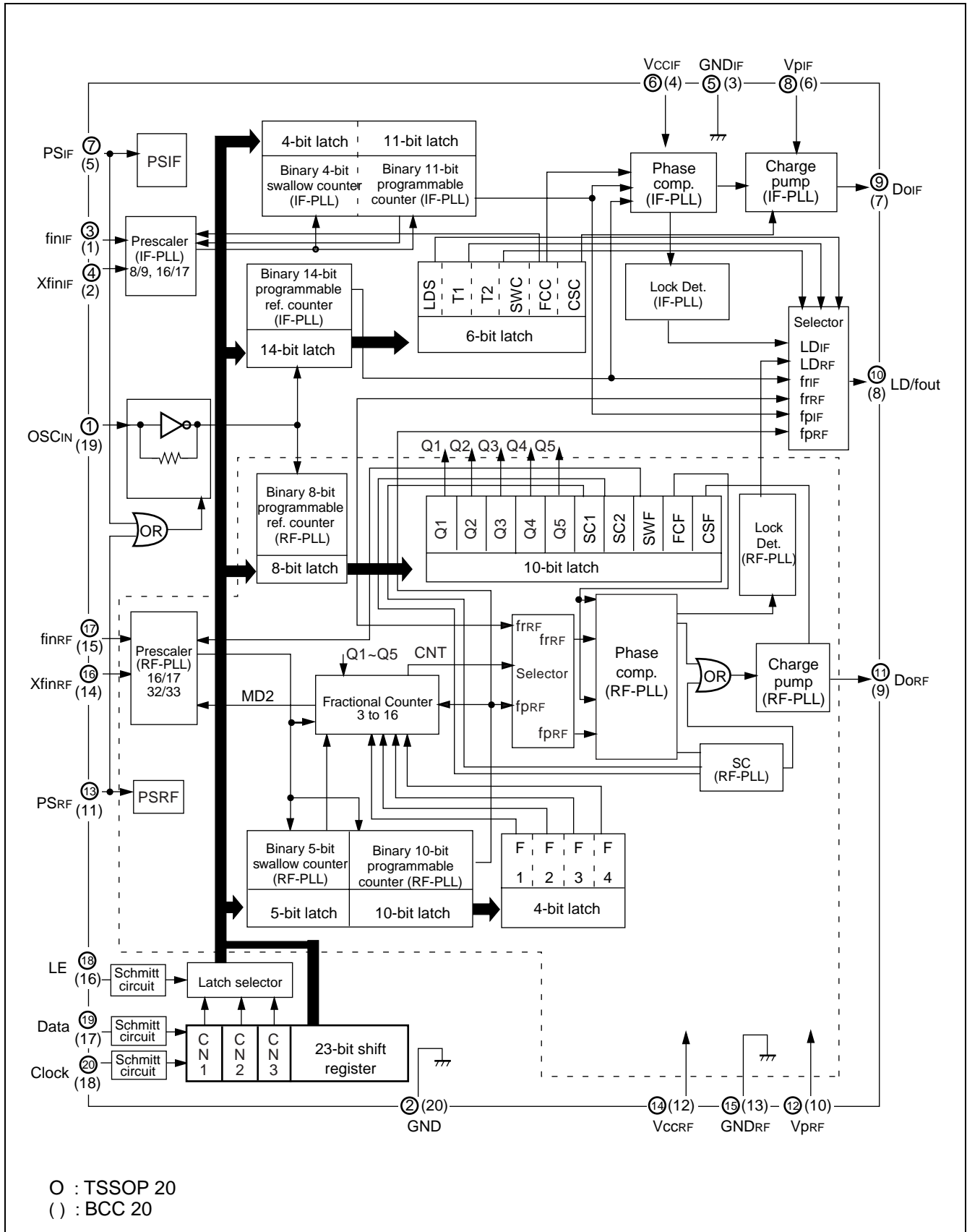

## ■ ABSOLUTE MAXIMUM RATINGS

Parameter		Symbol	Rating		Unit
			Min	Max	
Power supply voltage		V <sub>CC</sub>	-0.5	+4.0	V
		V <sub>p</sub>	V <sub>CC</sub>	+4.0	V
Input voltage		V <sub>i</sub>	-0.5	V <sub>CC</sub> + 0.5	V
Output voltage	LD / f <sub>out</sub>	V <sub>o</sub>	GND	V <sub>CC</sub>	V
	Do	V <sub>Do</sub>	GND	V <sub>p</sub>	V
Storage temperature		T <sub>stg</sub>	-55	+125	°C

Note : Permanent device damage may occur if the above **Absolute Maximum Ratings** are exceeded. Functional operation should be restricted to the conditions as detailed in the operational sections of this data sheet. Exposure to absolute maximum rating conditions for extended periods may affect device reliability.

WARNING: Semiconductor devices can be permanently damaged by application of stress (voltage, current, temperature, etc.) in excess of absolute maximum ratings. Do not exceed these ratings.

## ■ RECOMMENDED OPERATING CONDITIONS

Parameter	Symbol	Value			Unit	Remark
		Min	Typ	Max		
Power supply voltage	V <sub>CC</sub>	2.7	3.0	3.6	V	V <sub>CCRF</sub> = V <sub>CCIF</sub>
	V <sub>p</sub>	V <sub>CC</sub>	3.0	3.6	V	
Input voltage	V <sub>i</sub>	GND	—	V <sub>CC</sub>	V	
Operating temperature	T <sub>a</sub>	-40	—	+85	°C	

### Handling Precautions

- (1) V<sub>CCRF</sub>, V<sub>PRF</sub>, V<sub>CCIF</sub> and V<sub>PIF</sub> must supply equal voltage.  
Even if either RF-PLL or IF PLL is not used, power must be supplied to V<sub>CCRF</sub>, V<sub>PRF</sub>, V<sub>CCIF</sub> and V<sub>PIF</sub> to keep them equal. It is recommended that the non-use PLL is controlled by power saving function.
- (2) To protect against damage by electrostatic discharge, note the following handling precautions :
  - Store and transport devices in conductive containers.
  - Use properly grounded workstations, tools, and equipment.
  - Turn off power before inserting or removing this device into or from a socket.
  - Protect leads with conductive sheet, when transporting a board mounted device.

WARNING: The recommended operating conditions are required in order to ensure the normal operation of the semiconductor device. All of the device's electrical characteristics are warranted when the device is operated within these ranges.

Always use semiconductor devices within their recommended operating condition ranges. Operation outside these ranges may adversely affect reliability and could result in device failure.

No warranty is made with respect to uses, operating conditions, or combinations not represented on the data sheet. Users considering application outside the listed conditions are advised to contact their FUJITSU representatives beforehand.

# MB15F86UL

## ELECTRICAL CHARACTERISTICS

(V<sub>CC</sub> = 2.7 V to 3.6 V, T<sub>a</sub> = -40 °C to +85 °C)

Parameter	Symbol	Condition	Value			Unit	
			Min	Typ	Max		
Power supply current*1	I <sub>CCIF</sub> *1	fin <sub>IF</sub> = 480 MHz V <sub>CCIF</sub> = V <sub>pIF</sub> = 3.0 V, SW <sub>C</sub> = 0	1.0	1.6	2.3	mA	
	I <sub>CCRF</sub> *1	fin <sub>RF</sub> = 2000 MHz V <sub>CCRF</sub> = V <sub>pRF</sub> = 3.0 V, SW <sub>F</sub> = 1	2.8	4.2	5.8	mA	
Power saving current	I <sub>PSIF</sub>	PS = "L"	—	0.1*2	10	μA	
	I <sub>PSRF</sub>	PS = "L"	—	0.1*2	10	μA	
Operating frequency	fin <sub>IF</sub> *3	fin <sub>IF</sub>	IF PLL	100	—	600	MHz
	fin <sub>RF</sub> *3	fin <sub>RF</sub>	RF PLL	400	—	2000	MHz
	fin <sub>RF</sub> *3, *8	fin <sub>RF</sub>	RF PLL	400	—	2500	MHz
	OSC <sub>IN</sub>	f <sub>OSC</sub>	—	3	—	40	MHz
Input sensitivity	fin <sub>IF</sub>	Pfin <sub>IF</sub>	IF PLL, 50 Ω system	-15	—	+2	dBm
	fin <sub>RF</sub>	Pfin <sub>RF</sub>	RF PLL, 50 Ω system	-15	—	+2	dBm
	OSC <sub>IN</sub>	V <sub>OSC</sub>	—	0.5	—	V <sub>CC</sub>	Vp-p
"H" level input voltage	Data, Clock, LE	V <sub>IH</sub>	Schmitt trigger input	V <sub>CC</sub> × 0.7 + 0.4	—	—	V
"L" level input voltage		V <sub>IL</sub>	Schmitt trigger input	—	—	V <sub>CC</sub> × 0.3 - 0.4	
"H" level input voltage	PS <sub>IF</sub> ,	V <sub>IH</sub>	—	V <sub>CC</sub> × 0.7	—	—	V
"L" level input voltage	PS <sub>RF</sub>	V <sub>IL</sub>	—	—	—	V <sub>CC</sub> × 0.3	
"H" level input current	Data, Clock, LE, PS <sub>IF</sub> , PS <sub>RF</sub>	I <sub>IH</sub> *4	—	-1.0	—	+1.0	μA
"L" level input current		I <sub>IL</sub> *4	—	-1.0	—	+1.0	
"H" level input current	OSC <sub>IN</sub>	I <sub>IH</sub>	—	0	—	+100	μA
"L" level input current		I <sub>IL</sub> *4	—	-100	—	0	
"H" level output voltage	LD/ f <sub>out</sub>	V <sub>OH</sub>	V <sub>CC</sub> = V <sub>p</sub> = 3.0 V, I <sub>OH</sub> = -1 mA	V <sub>CC</sub> - 0.4	—	—	V
"L" level output voltage		V <sub>OL</sub>	V <sub>CC</sub> = V <sub>p</sub> = 3.0 V, I <sub>OL</sub> = 1 mA	—	—	0.4	
"H" level output voltage	DO <sub>IF</sub>	V <sub>DOH</sub>	V <sub>CC</sub> = V <sub>p</sub> = 3.0 V, I <sub>DOH</sub> = -0.5 mA	V <sub>p</sub> - 0.4	—	—	V
"L" level output voltage	DOR <sub>RF</sub>	V <sub>DOL</sub>	V <sub>CC</sub> = V <sub>p</sub> = 3.0 V, I <sub>DOL</sub> = 0.5 mA	—	—	0.4	
High impedance cutoff current	DO <sub>IF</sub> / DOR <sub>RF</sub>	I <sub>OFF</sub>	V <sub>CC</sub> = V <sub>p</sub> = 3.0 V V <sub>OFF</sub> = 0.5 V to V <sub>p</sub> - 0.5 V	—	—	2.5	nA
"H" level output current	LD/ f <sub>out</sub>	I <sub>OH</sub> *4	V <sub>CC</sub> = V <sub>p</sub> = 3.0 V	—	—	-1.0	mA
"L" level output current		I <sub>OL</sub> *4	V <sub>CC</sub> = V <sub>p</sub> = 3.0 V	1.0	—	—	

(Continued)

(Continued)

( $V_{CC} = 2.7\text{ V to }3.6\text{ V}$ ,  $T_a = -40\text{ }^\circ\text{C to }+85\text{ }^\circ\text{C}$ )

Parameter	Symbol	Condition	Value			Unit	
			Min	Typ	Max		
“H” level output current	Do <sub>IF</sub> Do <sub>RF</sub>	$V_{CC} = V_p = 3.0\text{ V}$ $V_{DOH} = V_p / 2$ $T_a = +25\text{ }^\circ\text{C}$	CS bit = “H”	-8.2	-6.0	-4.1	mA
			CS bit = “L”	-2.2	-1.5	-0.8	mA
“L” level output current		$V_{CC} = V_p = 3.0\text{ V}$ $V_{DOL} = V_p / 2$ $T_a = +25\text{ }^\circ\text{C}$	CS bit = “H”	4.1	6.0	8.2	mA
			CS bit = “L”	0.8	1.5	2.2	mA
Charge pump current rate	I <sub>DOL</sub> /I <sub>DOH</sub>	I <sub>DOMT</sub> <sup>*5</sup>	$V_{DO} = V_p / 2$	—	3	—	%
	vs V <sub>DO</sub>	I <sub>DOVD</sub> <sup>*6</sup>	$0.5\text{ V} \leq V_{DO} \leq V_p - 0.5\text{ V}$	—	10	—	%
	vs T <sub>a</sub>	I <sub>DOTA</sub> <sup>*7</sup>	$-40\text{ }^\circ\text{C} \leq T_a \leq +85\text{ }^\circ\text{C}$ , $V_{DO} = V_p / 2$	—	5	—	%

\*1 : Conditions ; f<sub>osc</sub> = 13 MHz, T<sub>a</sub> = +25 °C in locking state.

\*2 : V<sub>CCIF</sub> = V<sub>pIF</sub> = V<sub>CCRF</sub> = V<sub>pRF</sub> = 3.0 V, f<sub>osc</sub> = 13 MHz, T<sub>a</sub> = +25 °C, in power saving mode.

\*3 : AC coupling. 1000 pF capacitor is connected.

\*4 : The symbol “-” (minus) means direction of current flow.

\*5 :  $V_{CC} = V_p = 3.0\text{ V}$ ,  $T_a = +25\text{ }^\circ\text{C}$   $( (|I_3| - |I_4|) / [ (|I_3| + |I_4|) / 2] ) \times 100\text{ }(\%)$

\*6 :  $V_{CC} = V_p = 3.0\text{ V}$ ,  $T_a = +25\text{ }^\circ\text{C}$   $[ (|I_2| - |I_1|) / 2] / [ (|I_1| + |I_2|) / 2] \times 100\text{ }(\%)$  (Applied to each I<sub>DOL</sub> and I<sub>DOH</sub>)

\*7 :  $V_{CC} = V_p = 3.0\text{ V}$ ,  $[ (|I_{DO(85C)}| - |I_{DO(-40C)}|) / 2] / [ (|I_{DO(85C)}| + |I_{DO(-40C)}|) / 2] \times 100\text{ }(\%)$  (Applied to each I<sub>DOL</sub> and I<sub>DOH</sub>)

\*8 : In case of \*f<sub>max</sub> = 2500 MHz, the following conditions must be fulfilled. Except for it, f<sub>max</sub> is up to 2000 MHz.  
 Prescaler ratio = 32 (N > P) at all divide ratio of used operating frequency.  
 Refer to a calculation formula of divide ratio.  $f_{VCORF} = (P \times N + A + F / Q) \times f_{osc} / R$

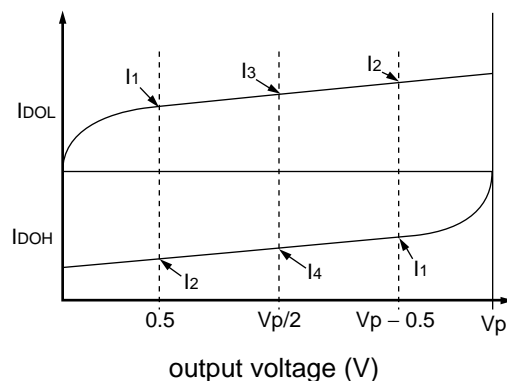

# MB15F86UL

## FUNCTIONAL DESCRIPTION

### Serial Data Input

Serial data is entered using three pins, Data pin, Clock pin, and LE pin. Programmable dividers of IF/RF-PLL sections and programmable reference dividers of IF/RF-PLL sections are controlled individually.

Serial data of binary code is entered through Data pin.

On a rising edge of clock, one bit of serial data is transferred into the shift register. On a rising edge of load enable signal, the data stored in the shift register is transferred to one of latches depending upon the control bit data setting.

### Control Bit

	The programmable reference counter for the IF-PLL	The programmable counter and the swallow counter for the IF-PLL	The programmable reference counter for the RF-PLL	The programmable counter and the swallow counter for the RF-PLL
CN1	0	1	0	1
CN2	0	0	1	1
CN3	0	0	0	0

Note : CN3 = 1 is prohibited

### (1) Serial data format

Direction of data shift →																						
MSB																						
1	2	3	4	5	6	7	8	9	10	11	12	13	14	15	16	17	18	19	20	21	22	23
0	0	0	RC1	RC2	RC3	RC4	RC5	RC6	RC7	RC8	RC9	RC10	RC11	RC12	RC13	RC14	LDS	T1	T2	SWC	FCc	CSc
1	0	0	AC1	AC2	AC3	AC4	0	0	0	NC1	NC2	NC3	NC4	NC5	NC6	NC7	NC8	NC9	NC10	NC11	X	X
0	1	0	RF1	RF2	RF3	RF4	RF5	RF6	RF7	RF8	0	Q1	Q2	Q3	Q4	Q5	0	SC1	SC2	SWF	FCF	CSF
1	1	0	AF1	AF2	AF3	AF4	AF5	NF1	NF2	NF3	NF4	NF5	NF6	NF7	NF8	NF9	NF10	F1	F2	F3	F4	0

↑ Control bit (CN3)  
 ↑ Control bit (CN2)  
 ↑ Control bit (CN1)

RC1 to RC14 : Divide ratio setting bits for the reference counter of the IF (3 to 16383)  
 AC1 to AC4 : Divide ratio setting bits for the swallow counter of the IF (0 to 15, A < N)  
 NC1 to NC11 : Divide ratio setting bits for the programmable counter of the IF (3 to 2047)  
 LDS, T1, T2 : Select bits for the lock detect output or a monitoring phase comparison frequency  
 SWC : Divide ratio setting for the prescaler of the IF  
 FCc : Phase control bit for the phase detector of the IF  
 CSc : Charge pump current select bit of the IF  
 RF1 to RF8 : Divide ratio setting bits for the reference counter of the RF (3 to 255)  
 Q1 to Q5 : Fractional-N increment setting bit (3 to 16)  
 AF1 to AF5 : Divide ratio setting bits for the swallow counter of the RF (0 to 31, A < N - 2)  
 NF1 to NF10 : Divide ratio setting bits for the programmable counter of the RF (18 to 1023)  
 F1 to F4 : Fractional-N increment setting bit for the fractional accumulator (0 to 15, F < Q)  
 SC1, SC2 : Spurious cancel set bit of the RF.  
 SWF : Divide ratio setting for the prescaler of the RF  
 FCF : Phase control bit for the phase detector of the RF.  
 CSF : Charge pump current select bit of the RF  
 X : Dummy bit (Set "0" or "1")

Note: Data input with MSB first.

## (2) Data Setting

### • RF synthesizer Data Setting (Fractional-N)

The divide ratio can be calculated using the following equation :

$$f_{V\text{CORF}} = N_{\text{TOTAL}} \times f_{\text{OSC}} \div R$$

$$N_{\text{TOTAL}} = P \times N + A + F / Q \quad \leftarrow \quad (A < N - 2, F < Q)$$

$f_{V\text{CORF}}$  : Output frequency of external voltage controlled oscillator (VCO)

$N_{\text{TOTAL}}$  : Total division ratio from prescaler input to the phase detector input

$f_{\text{OSC}}$  : Output frequency of the reference frequency oscillator

$R$  : Preset divide ratio of binary 8 bit reference counter (3 to 255)

$P$  : Preset divide ratio of modulus prescaler (16 or 32)

$N$  : Preset divide ratio of binary 10 bit programmable counter (18 to 1023)

$A$  : Preset divide ratio of binary 5 bit swallow counter (0 to 31)

$F$  : A numerator of fractional-N (0 to 15)

$Q$  : A denominator of fractional-N, modulo 3 to 16

Note : When  $Q$  is set more than 10, a prescaler ratio should be set 32.

### • Binary 8-bit Programmable Reference Counter Data Setting ( $R_{F1}$ to $R_{F8}$ )

Divide ratio (R)	$R_{F8}$	$R_{F7}$	$R_{F6}$	$R_{F5}$	$R_{F4}$	$R_{F3}$	$R_{F2}$	$R_{F1}$
3	0	0	0	0	0	0	1	1
4	0	0	0	0	0	1	0	0
—	—	—	—	—	—	—	—	—
52	0	0	1	1	0	1	0	0
—	—	—	—	—	—	—	—	—
255	1	1	1	1	1	1	1	1

Note : Divide ratio less than 3 is prohibited.

### • Fractional-N numerator of the fractional accumulator Data Setting (F1 to F4)

Setting value(F)	F4	F3	F2	F1
0	0	0	0	0
1	0	0	0	1
2	0	0	1	0
—	—	—	—	—
15	1	1	1	1

Note :  $F < Q$

### • Fractional-N denominator of the fractional accumulator Data Setting (Q1 to Q5)

Setting value(Q)	Q5	Q4	Q3	Q2	Q1
3	0	0	0	1	1
4	0	0	1	0	0
5	0	0	1	0	1
—	—	—	—	—	—
16	1	0	0	0	0

Note :  $F < Q$

# MB15F86UL

- Binary 10-bit Programmable Counter Data Setting ( $N_{F1}$  to  $N_{F10}$ )

Divide ratio (N)	$N_{F10}$	$N_{F9}$	$N_{F8}$	$N_{F7}$	$N_{F6}$	$N_{F5}$	$N_{F4}$	$N_{F3}$	$N_{F2}$	$N_{F1}$
18	0	0	0	0	0	1	0	0	1	0
19	0	0	0	0	0	1	0	0	1	1
—	—	—	—	—	—	—	—	—	—	—
32	0	0	0	0	1	0	0	0	0	0
—	—	—	—	—	—	—	—	—	—	—
1023	1	1	1	1	1	1	1	1	1	1

Note : Divide ratio less than 18 is prohibited.

- Binary 5-bit Swallow Counter Data Setting ( $A_{F1}$  to  $A_{F5}$ )

Divide ratio (A)	$A_{F5}$	$A_{F4}$	$A_{F3}$	$A_{F2}$	$A_{F1}$
0	0	0	0	0	0
1	0	0	0	0	1
2	0	0	0	1	0
—	—	—	—	—	—
31	1	1	1	1	1

Note :  $A < N - 2$

- Charge pump current select Bit Setting

$CS_F$	Current value
1	$\pm 6.0$ mA
0	$\pm 1.5$ mA

- Spurious cancel Bit Setting

Spurious cancel amount	SC1	SC2
Large	0	0
Midium	0	1
Small	1	0

Note : The bits set how much the amount of spurious cancel.  
If the Large is selected, a spurious is tended to become small.

- Prescaler Data Setting ( $SW_F$ )

$SW_F$	Prescaler divide ratio
1	16/17
0	32/33

• **IF synthesizer Data Setting (Integer)**

The divide ratio can be calculated using the following equation :

$$f_{VCOIF} = [(P \times N) + A] \times f_{osc} \div R \quad (A < N)$$

$f_{VCOIF}$  : Output frequency of external voltage controlled oscillator (VCO)

P : Preset divide ratio of modulus prescaler (8 or 16)

N : Preset divide ratio of binary 11 bit programmable counter (3 to 2047)

A : Preset divide ratio of binary 4 bit swallow counter (0 to 15)

$f_{osc}$  : Output frequency of the reference frequency oscillator

R : Preset divide ratio of binary 14 bit reference counter (3 to 16383)

• **Binary 14-bit Programmable Reference Counter Data Setting ( $R_{C1}$  to  $R_{C14}$ )**

Divide ratio (R)	$R_{C14}$	$R_{C13}$	$R_{C12}$	$R_{C11}$	$R_{C10}$	$R_{C9}$	$R_{C8}$	$R_{C7}$	$R_{C6}$	$R_{C5}$	$R_{C4}$	$R_{C3}$	$R_{C2}$	$R_{C1}$
3	0	0	0	0	0	0	0	0	0	0	0	0	1	1
4	0	0	0	0	0	0	0	0	0	0	0	1	0	0
—	—	—	—	—	—	—	—	—	—	—	—	—	—	—
16383	1	1	1	1	1	1	1	1	1	1	1	1	1	1

Note : Divide ratio less than 3 is prohibited.

• **Binary 11-bit Programmable Counter Data Setting ( $N_{C1}$  to  $N_{C11}$ )**

Divide ratio (N)	$N_{C11}$	$N_{C10}$	$N_{C9}$	$N_{C8}$	$N_{C7}$	$N_{C6}$	$N_{C5}$	$N_{C4}$	$N_{C3}$	$N_{C2}$	$N_{C1}$
3	0	0	0	0	0	0	0	0	0	1	1
4	0	0	0	0	0	0	0	0	1	0	0
—	—	—	—	—	—	—	—	—	—	—	—
2047	1	1	1	1	1	1	1	1	1	1	1

Note : Divide ratio less than 3 is prohibited.

• **Binary 4-bit Swallow Counter Data Setting ( $A_{C1}$  to  $A_{C4}$ )**

Divide ratio (A)	$A_{C4}$	$A_{C3}$	$A_{C2}$	$A_{C1}$
0	0	0	0	0
1	0	0	0	1
2	0	0	1	0
—	—	—	—	—
15	1	1	1	1

Note :  $A < N$

• **Prescaler Data Setting ( $SW_c$ )**

$SW_c$	Prescaler divide ratio
1	8/9
0	16/17

# MB15F86UL

- Charge pump current select Data Setting (CS<sub>c</sub>)

CS <sub>c</sub>	Do current
1	± 6.0 mA
0	± 1.5 mA

- **Common setting**

- LD/fout Output Select Data Setting

LD/fout		LDS	T1	T2
LD output		0	—	—
fout output	f <sub>rIF</sub>	1	0	0
	f <sub>rRF</sub>	1	1	0
	f <sub>pIF</sub>	1	0	1
	f <sub>pRF</sub>	1	1	1

- Phase Comparator Phase Switching Data Setting

	FC <sub>F/C</sub> = High	FC <sub>F/C</sub> = Low
	D <sub>OIF, RF</sub>	
f <sub>r</sub> > f <sub>p</sub>	H	L
f <sub>r</sub> = f <sub>p</sub>	Z	Z
f <sub>r</sub> < f <sub>p</sub>	L	H
VCO polarity	1	2

Notes : • Z = High-Z

- Depending upon the VCO and LPF polarity, FC bit should be set.

When designing a synthesizer, the FC bit setting depends on the VCO and LPF characteristics.

When the LPF and VCO characteristics are similar to (1) ,  
set FC bit "H".

When the VCO characteristics are similar to (2) ,  
set FC bit "L".

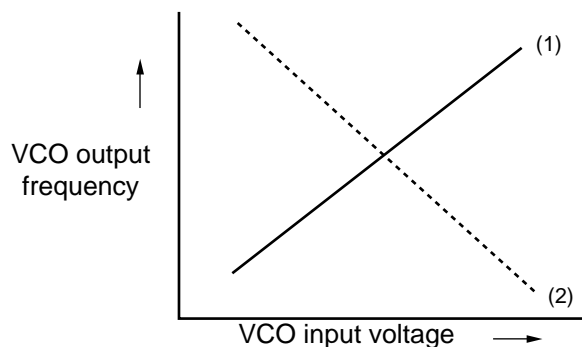

• **Power Saving Mode (Intermittent Mode Control)**

• PS Pin Setting

PS pin	Status
H	Normal mode
L	Power saving mode

The intermittent mode control circuit reduces the PLL power consumption.

By setting the PS pin low, the device enters the power saving mode, reducing the current consumption. See “■ ELECTRICAL CHARACTERISTICS” for the specific value.

The phase detector output, Do, becomes high impedance.

For the dual PLL, the lock detector, LD, is shown in the LD Output Logic table.

Setting the PS pin high releases the power saving mode, and the device works normally.

The intermittent mode control circuit also ensures a smooth start-up when the device returns to normal operation. When the PLL is returned to normal operation, the phase comparator output signal is unpredictable. This is because of the unknown relationship between the comparison frequency ( $f_p$ ) and the reference frequency ( $f_r$ ) which can cause a major change in the comparator output, resulting in a VCO frequency jump and an increase in lockup time.

To prevent a major VCO frequency jump, the intermittent mode control circuit limits the magnitude of the error signal from the phase detector when it returns to normal operation.

- Notes:
- When power ( $V_{CC}$ ) is first applied, the device must be in standby mode and PS = Low, for at least 1  $\mu$ s.
  - PS pin must be set “L” for Power ON and then the PS mode should be removed after input serial data.

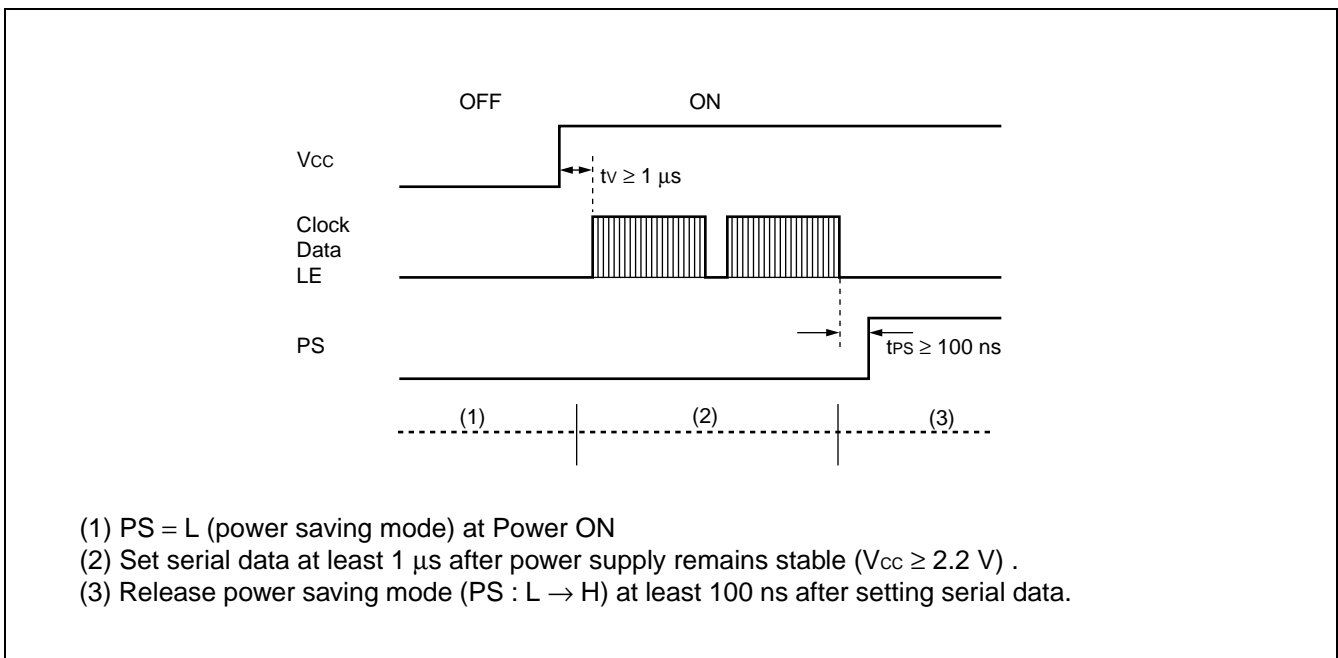

## ■ SERIAL DATA INPUT TIMING

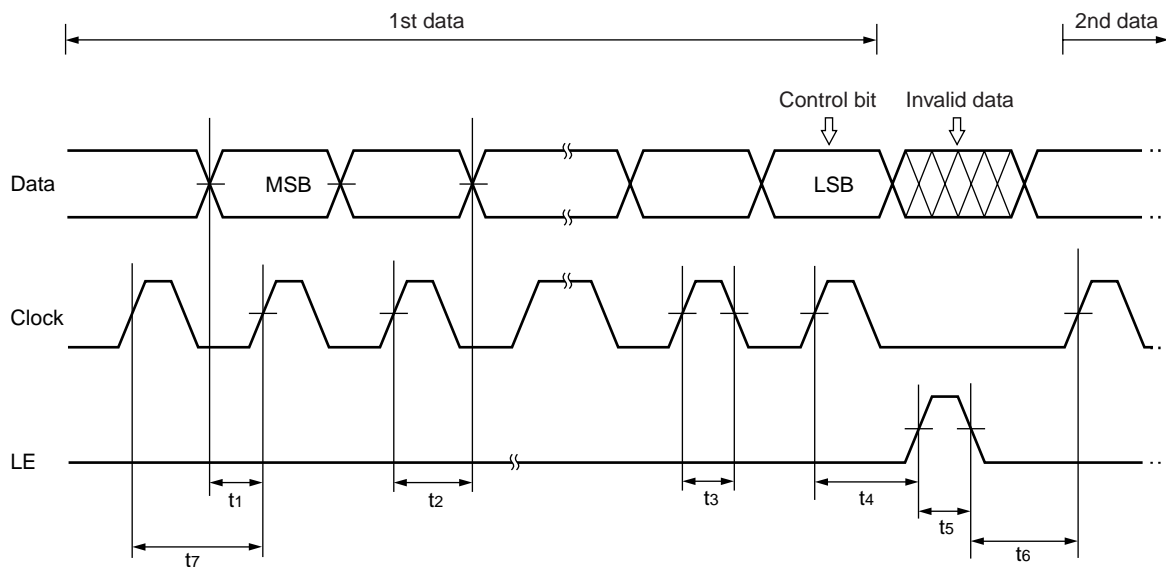

On the rising edge of the clock, one bit of data is transferred into shift register.

Parameter	Min	Typ	Max	Unit
$t_1$	20	—	—	ns
$t_2$	20	—	—	ns
$t_3$	30	—	—	ns
$t_4$	30	—	—	ns

Parameter	Min	Typ	Max	Unit
$t_5$	100	—	—	ns
$t_6$	20	—	—	ns
$t_7$	100	—	—	ns

Note : LE should be "L" when the data is transferred into the shift register.

## ■ PHASE DETECTOR OUTPUT WAVEFORM

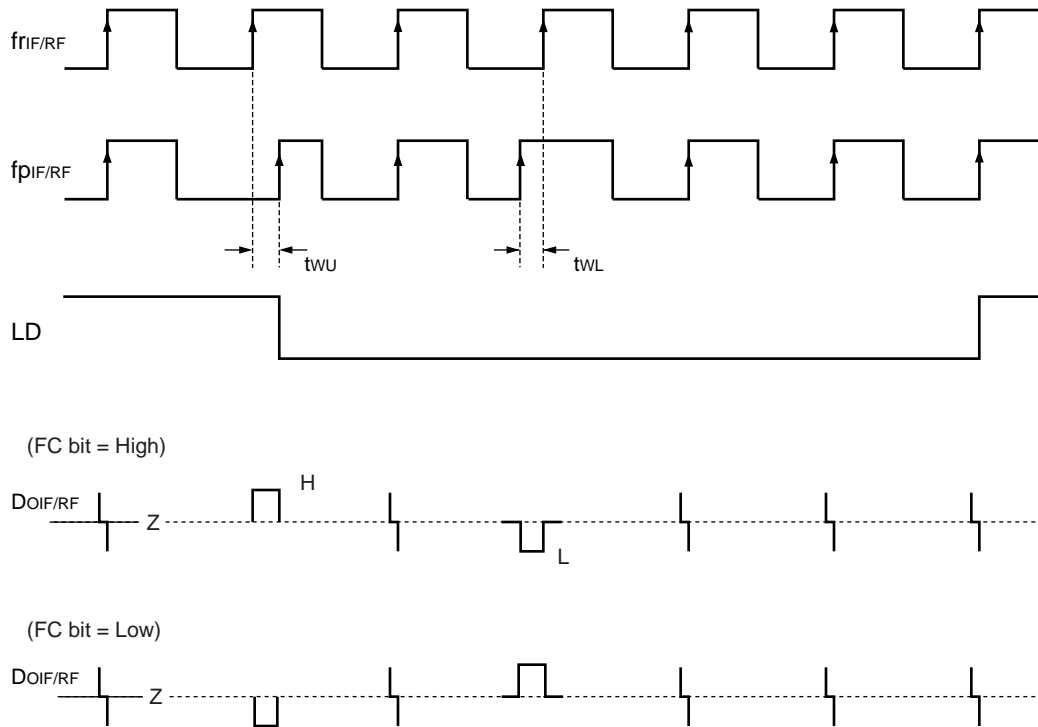

(FC bit = High)

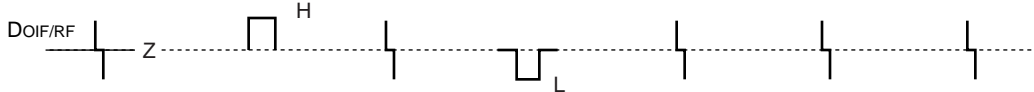

(FC bit = Low)



**LD Output Logic Table**

IF-PLL section	RF-PLL section	LD output
Locking state/Power saving state	Locking state/Power saving state	H
Locking state/Power saving state	Unlocking state	L
Unlocking state	Locking state/Power saving state	L
Unlocking state	Unlocking state	L

- Notes:
- Phase error detection range =  $-2\pi$  to  $+2\pi$
  - Pulses on DOIF/RF signals are output to prevent dead zone.
  - LD output becomes low when phase error is  $t_{wU}$  or more.
  - LD output becomes high when phase error is  $t_{wL}$  or less and continues to be so for three cycles or more.
  - $t_{wU}$  and  $t_{wL}$  depend on OSC<sub>IN</sub> input frequency as follows.
    - $t_{wU} \geq 2/f_{osc}$  [s] : i.e.  $t_{wU} \geq 153.8$  ns when  $f_{osc} = 13.0$  MHz
    - $t_{wL} \leq 4/f_{osc}$  [s] : i.e.  $t_{wL} \leq 307.7$  ns when  $f_{osc} = 13.0$  MHz

# MB15F86UL

## ■ TEST CIRCUIT (for Measuring Input Sensitivity $f_{in}/OSC_{IN}$ )

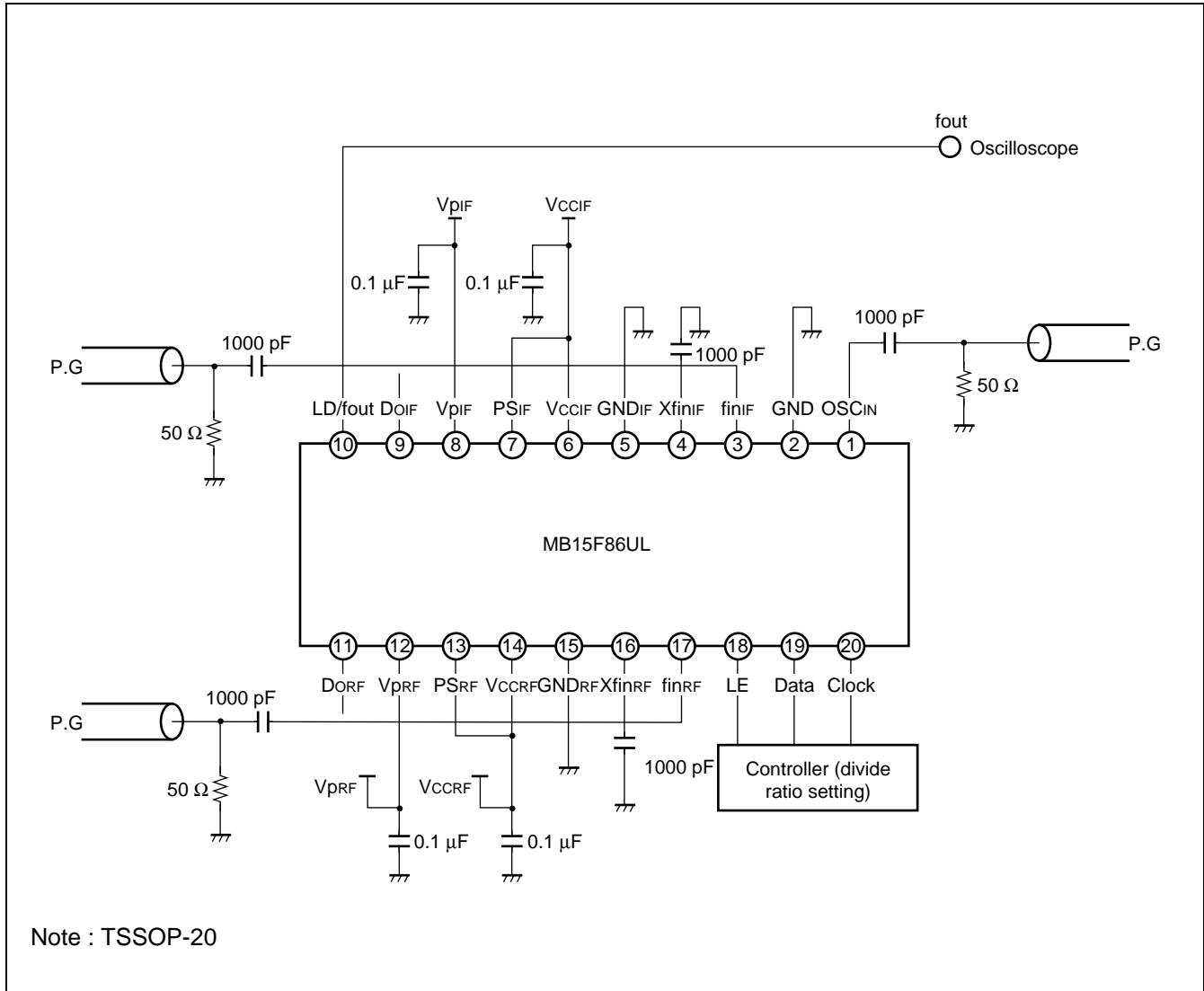

## TYPICAL CHARACTERISTICS

### 1. fin input sensitivity

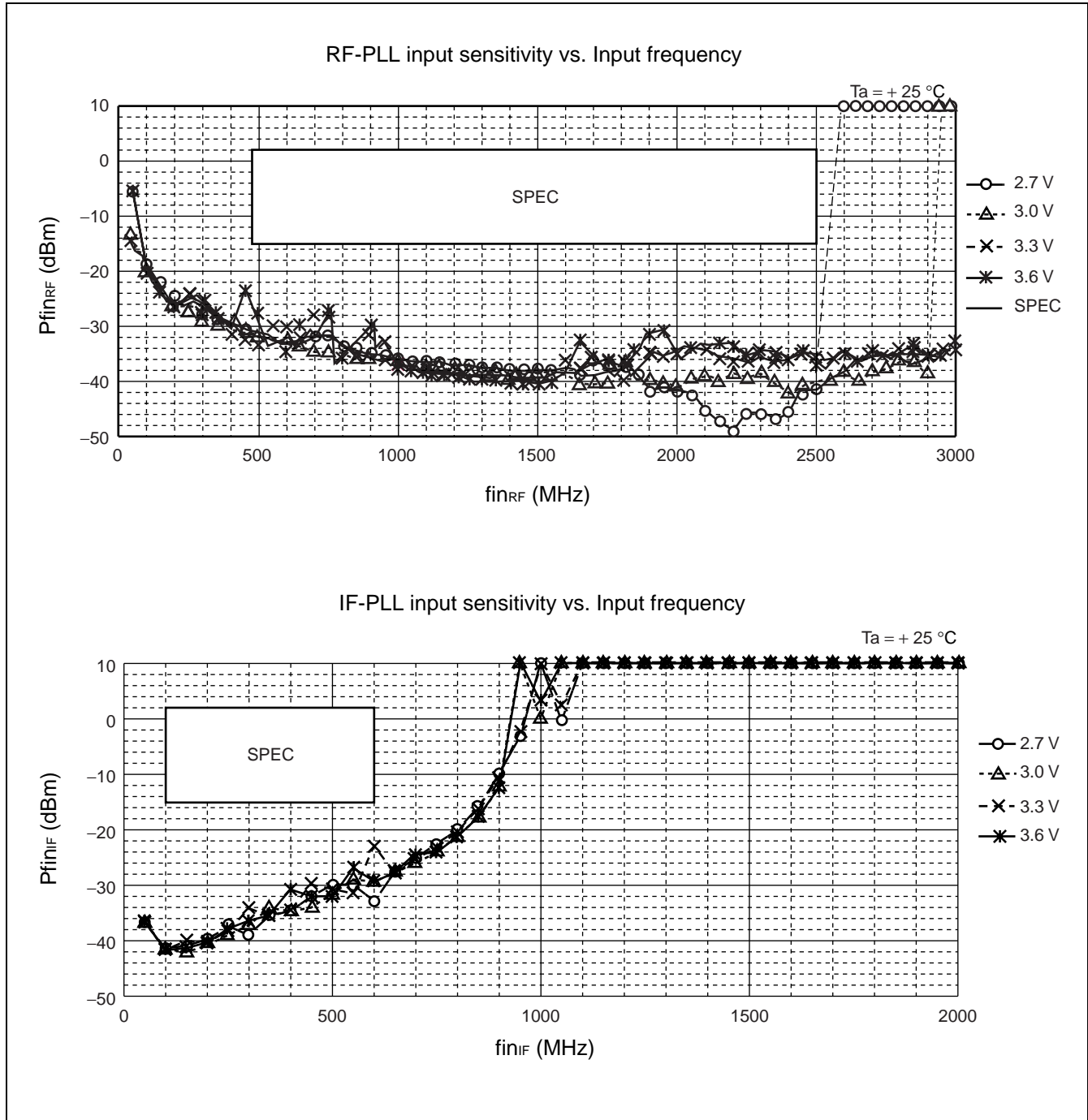

# MB15F86UL

## 2. OSC<sub>IN</sub> input sensitivity

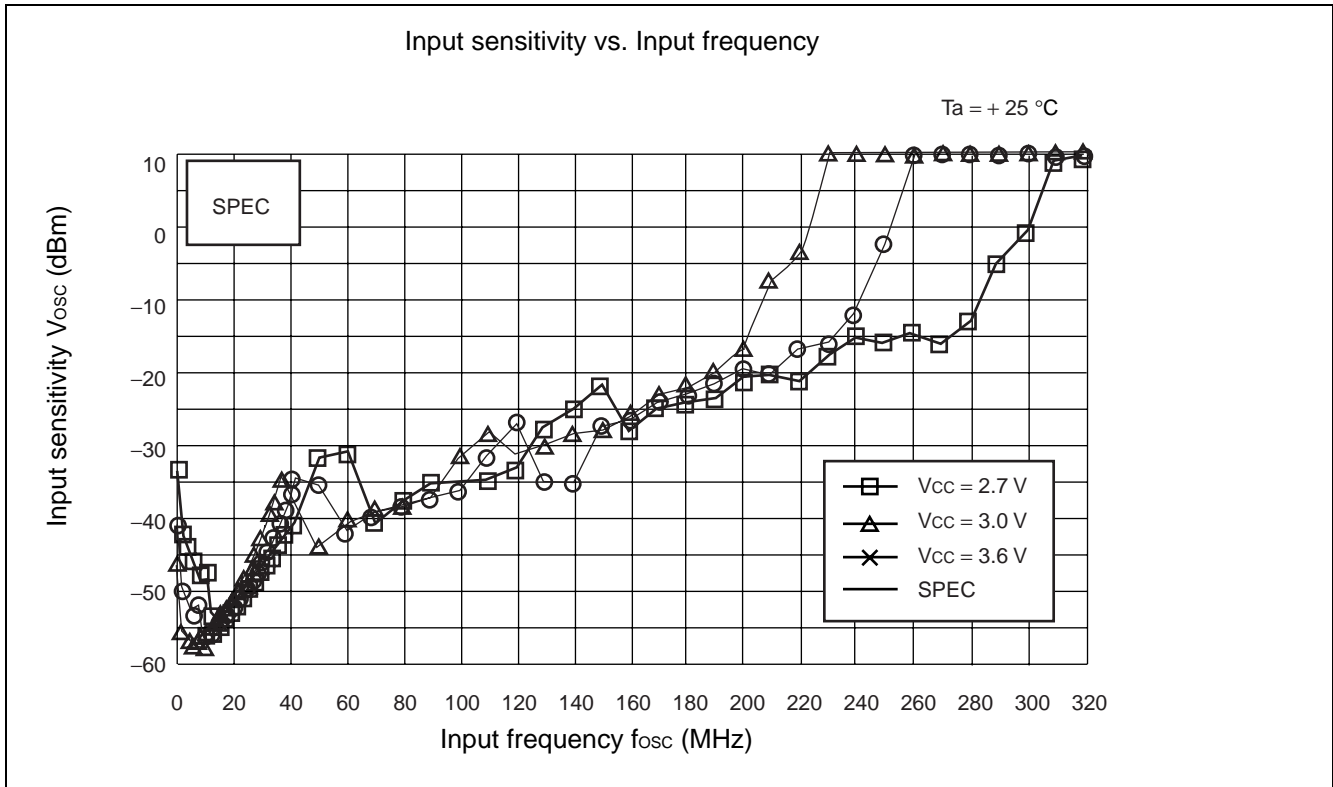

## 3. RF-PLL D<sub>o</sub> output current

- 1.5 mA mode

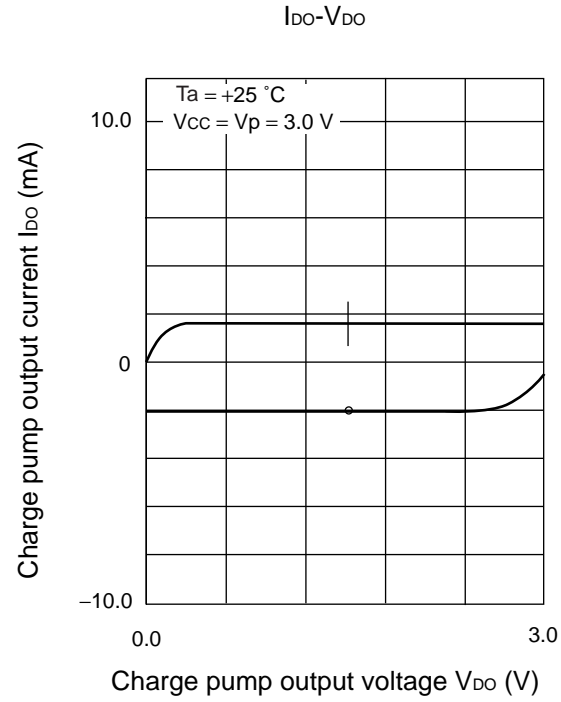

- 6.0 mA mode

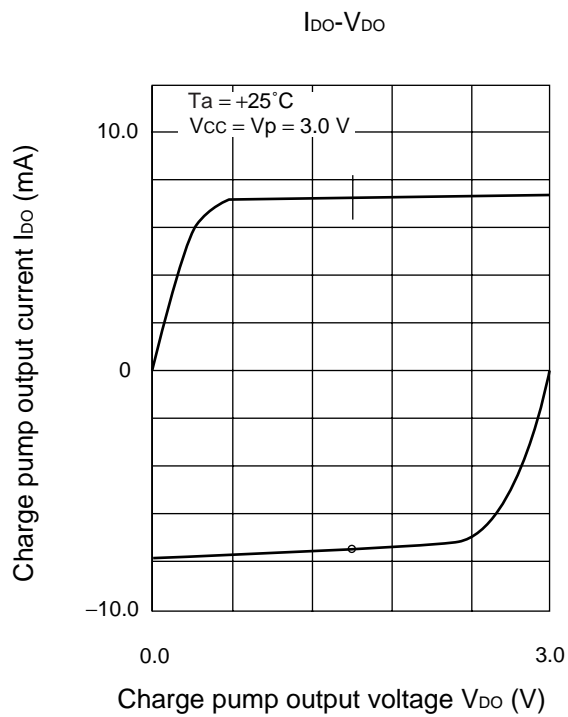

## 4. IF-PLL Do output current

- 1.5 mA mode

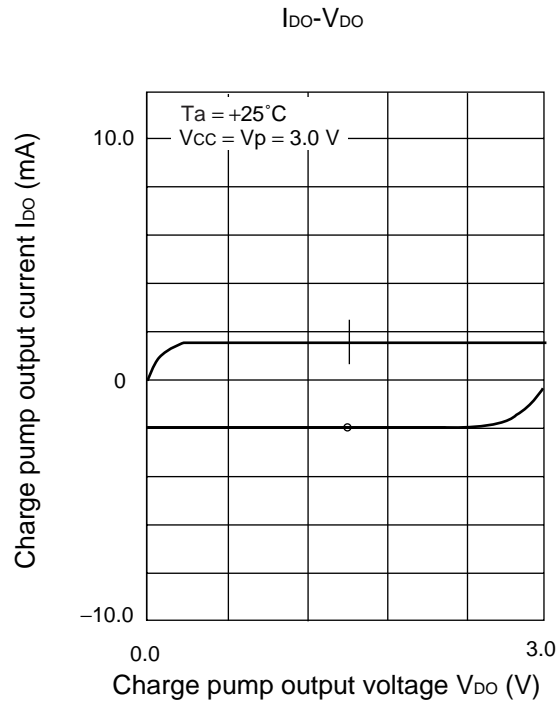

- 6.0 mA mode

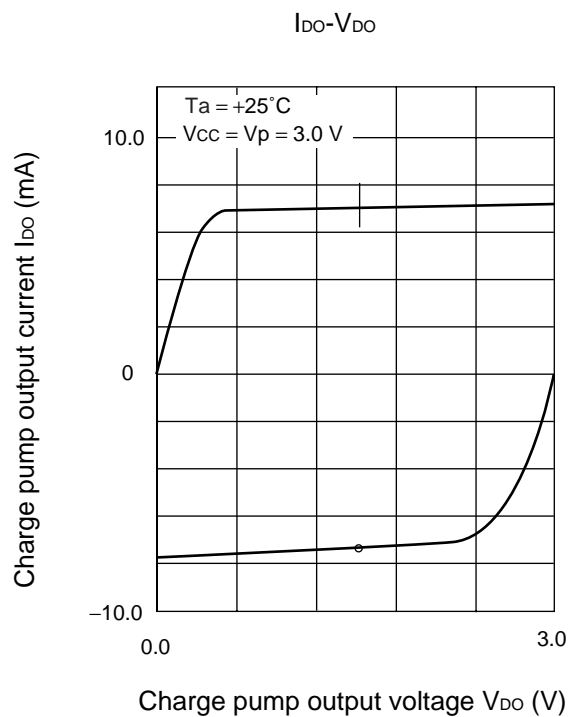

## 5. fin input impedance

fin<sub>RF</sub> input impedance

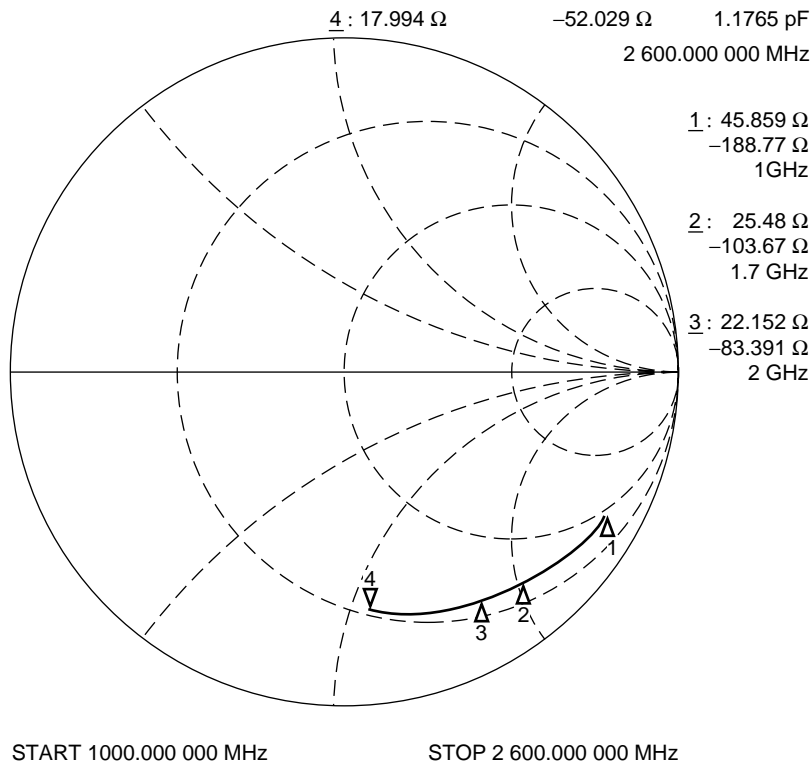

fin<sub>IF</sub> input impedance

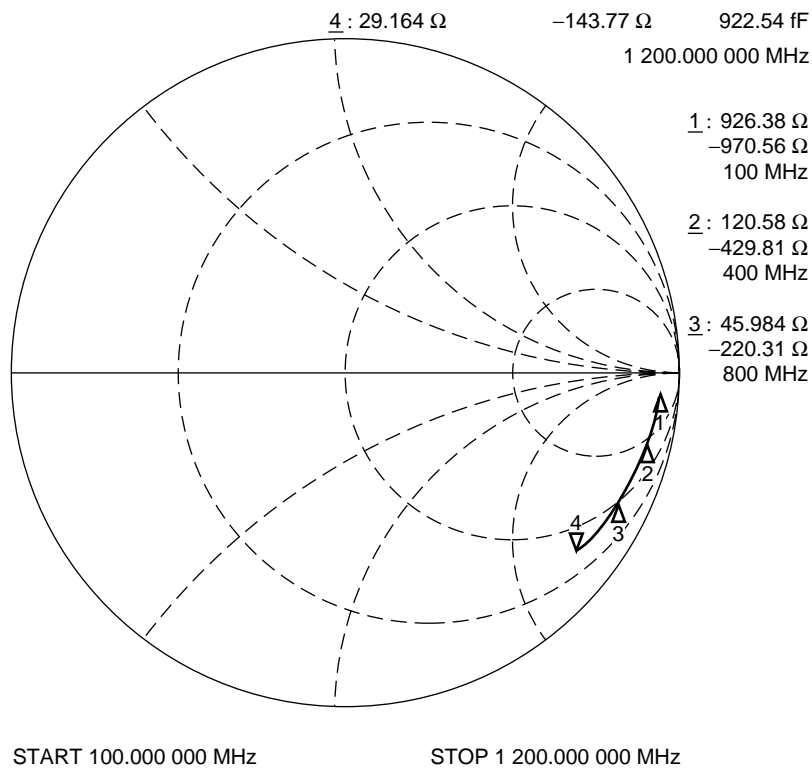

## 6. OSC<sub>IN</sub> input impedance

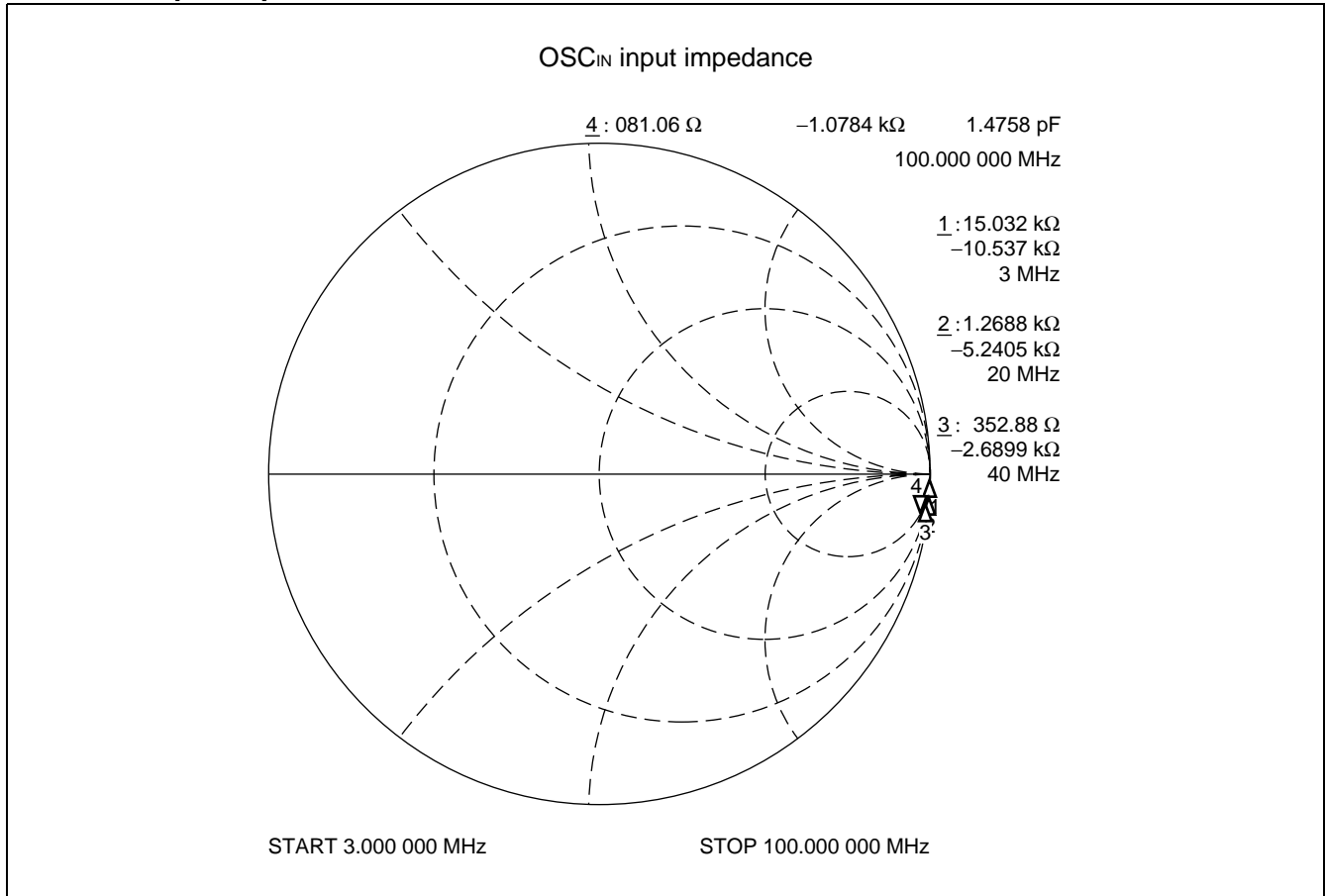

## REFERENCE INFORMATION

(for Lock-up Time, Phase Noise and Reference Leakage)

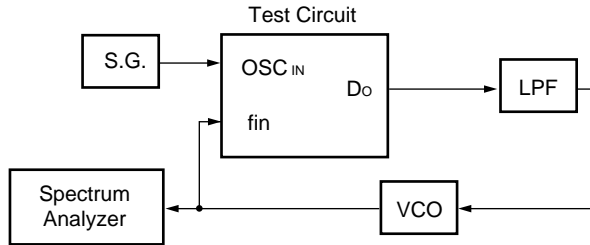

$f_{VCO} = 1741.5 \text{ MHz}$      $V_{CC} = 3.0 \text{ V}$   
 $K_V = 44 \text{ MHz/V}$      $V_{VCO} = 3.5 \text{ V}$   
 $f_r = 30 \text{ kHz}$      $T_a = +25 \text{ }^\circ\text{C}$   
 $f_{osc} = 19.44 \text{ MHz}$      $CP : 6 \text{ mA mode}$   
 LPF

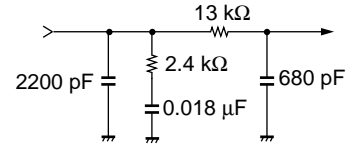

### • PLL Reference Leakage

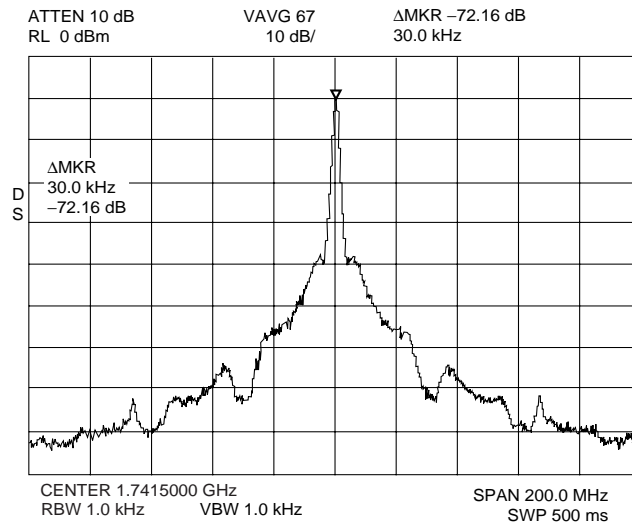

### • PLL Phase Noise

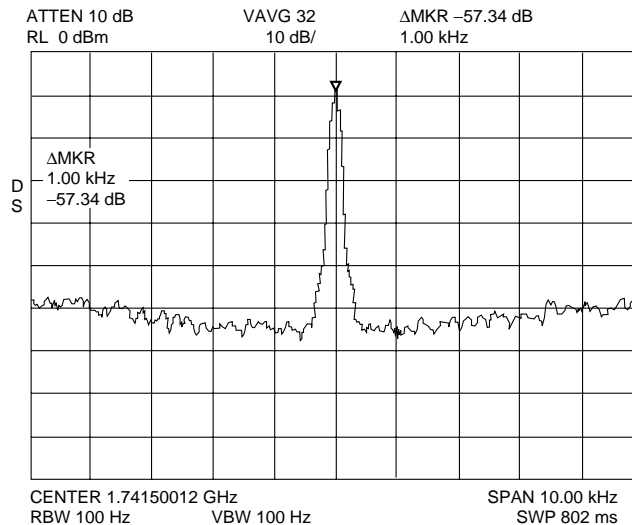

(Continued)

(Continued)

• PLL Lock Up time

1741.5 MHz → 1801.5 MHz within  $\pm 1$  kHz  
Lch → Hch      844  $\mu$ s

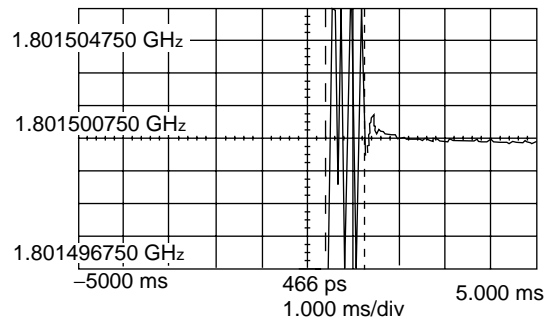

• PLL Lock Up time

1801.5 MHz → 1741.5 MHz within  $\pm 1$  kHz  
Hch → Lch      889  $\mu$ s

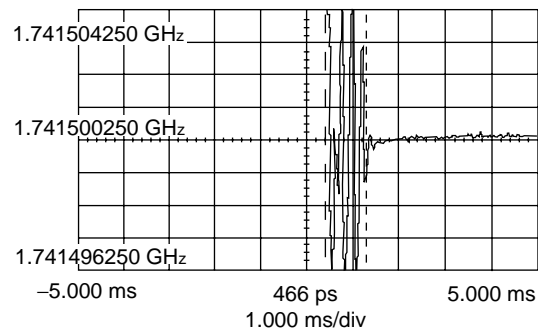

## APPLICATION EXAMPLE

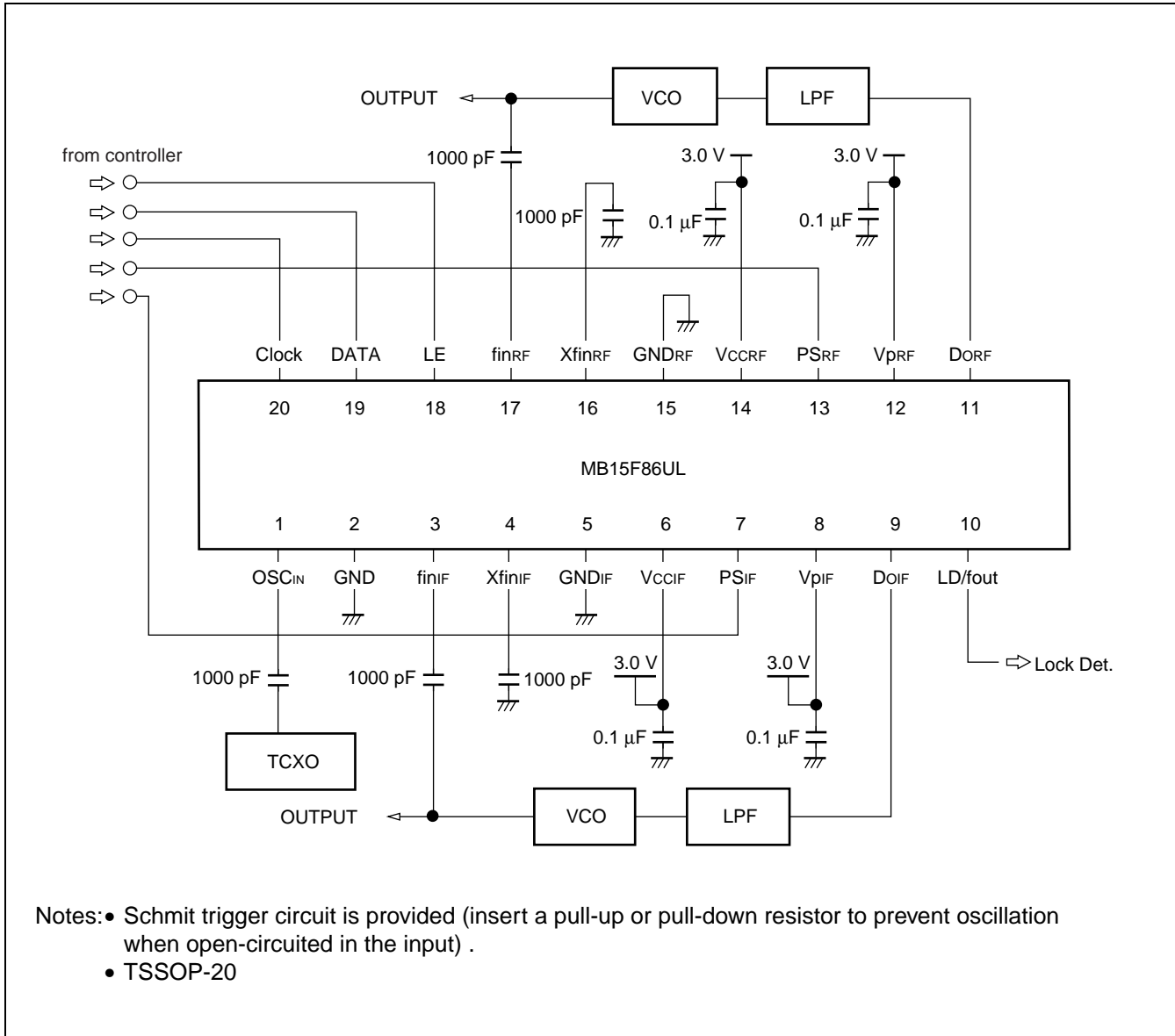

## ORDERING INFORMATION

Part Number	Package	Remark
MB15F86ULPFT	20-pin plastic TSSOP (FPT-20P-M06)	
MB15F86ULPVA	20-pad plastic BCC (LCC-20P-M05)	

# MB15F86UL

## PACKAGE DIMENSIONS

20-pin Plastic TSSOP  
(FPT-20P-M06)

\* : These dimensions do not include resin protrusion.

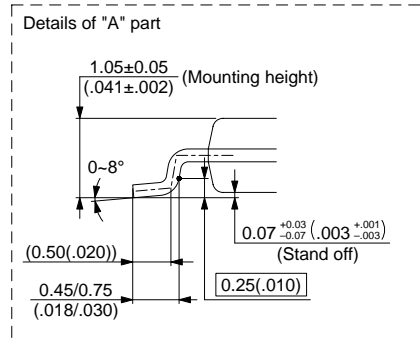
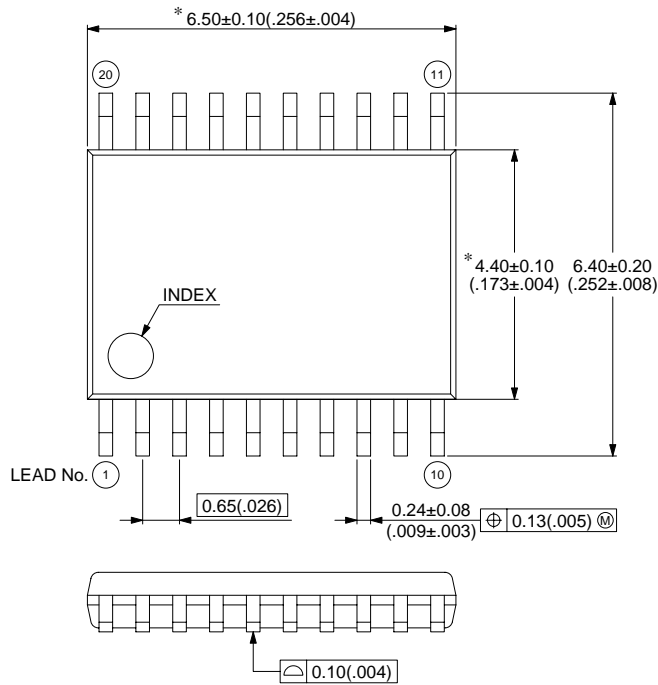

© 1999 FUJITSU LIMITED F20026S-2C-2

Dimensions in mm (inches)

(Continued)

(Continued)

## 20-pad plastic BCC (LCC-20P-M05)

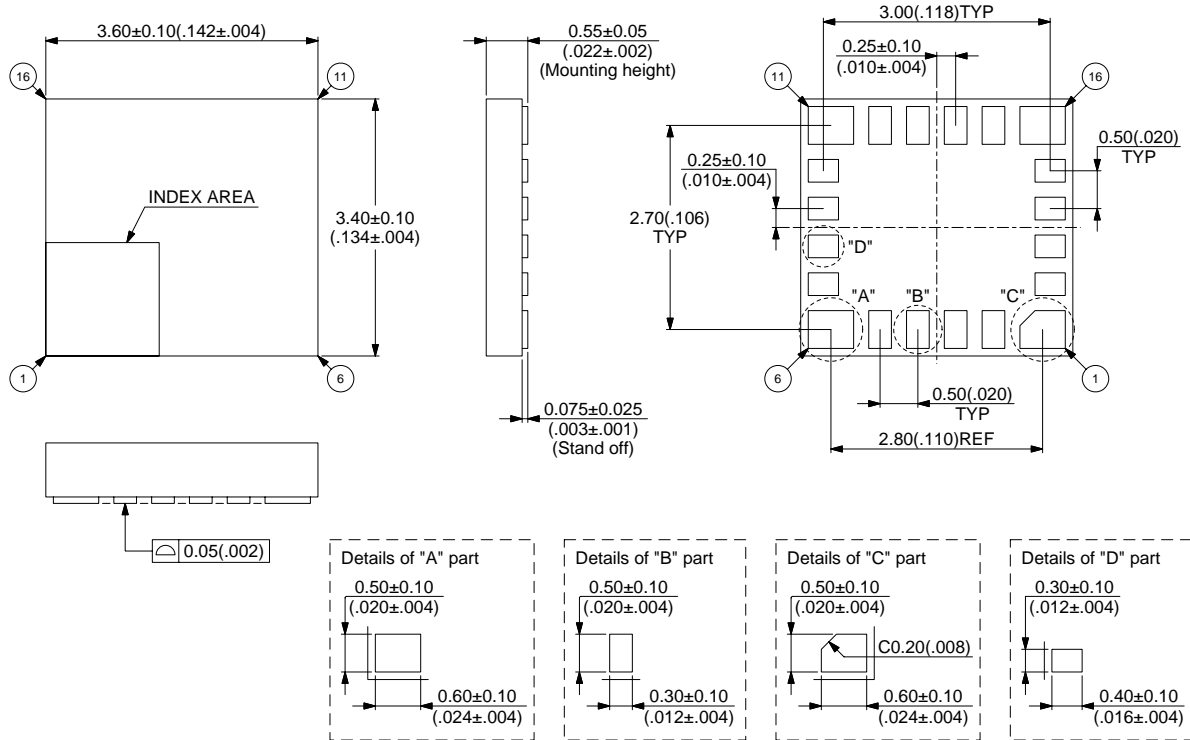

© 2001 FUJITSU LIMITED C20056S-c-2-1

Dimensions in mm (inches)

## FUJITSU LIMITED

All Rights Reserved.

The contents of this document are subject to change without notice. Customers are advised to consult with FUJITSU sales representatives before ordering.

The information and circuit diagrams in this document are presented as examples of semiconductor device applications, and are not intended to be incorporated in devices for actual use. Also, FUJITSU is unable to assume responsibility for infringement of any patent rights or other rights of third parties arising from the use of this information or circuit diagrams.

The products described in this document are designed, developed and manufactured as contemplated for general use, including without limitation, ordinary industrial use, general office use, personal use, and household use, but are not designed, developed and manufactured as contemplated (1) for use accompanying fatal risks or dangers that, unless extremely high safety is secured, could have a serious effect to the public, and could lead directly to death, personal injury, severe physical damage or other loss (i.e., nuclear reaction control in nuclear facility, aircraft flight control, air traffic control, mass transport control, medical life support system, missile launch control in weapon system), or (2) for use requiring extremely high reliability (i.e., submersible repeater and artificial satellite).

Please note that Fujitsu will not be liable against you and/or any third party for any claims or damages arising in connection with above-mentioned uses of the products.

Any semiconductor devices have an inherent chance of failure. You must protect against injury, damage or loss from such failures by incorporating safety design measures into your facility and equipment such as redundancy, fire protection, and prevention of over-current levels and other abnormal operating conditions.

If any products described in this document represent goods or technologies subject to certain restrictions on export under the Foreign Exchange and Foreign Trade Law of Japan, the prior authorization by Japanese government will be required for export of those products from Japan.

F0111

© FUJITSU LIMITED Printed in Japan