

# MCU Development Tools

- Fujitsu SOFTUNE™ IDE support for C/C++
- Integrated quality/performance analyzing tools
- Integrated debugger modules
- REALOS™ support
- Easy-to-use high-performance emulator tools
- Low-cost evaluation boards and starter kits



Fujitsu offers a wide range of development tools for its F<sup>2</sup>MC and FR family microcontrollers. Development tools include an easy-to-use, integrated software development environment called SOFTUNE™, in-circuit emulator tools to help debug real-time applications, and the evaluation boards required for application development.

## F<sup>2</sup>MC-8FX Family Development Tools

### Features

A compact size, combined with the power to cost-effectively support microcontroller system designers, makes Fujitsu's MB2146-09 a highly valuable support tool.

This adapter and evaluation board for F<sup>2</sup>MC-8FX series offers the ability to emulate microcontrollers operating at a voltage range of 2.7V to 5.5V. The MB2146-09 supports sophisticated debugging features such as multi-level breakpoints, bit-level event triggers and high-level languages. The emulation environment runs under Windows 98 or NT/2000/XP.

### F<sup>2</sup>MC-8FX Emulator Configuration

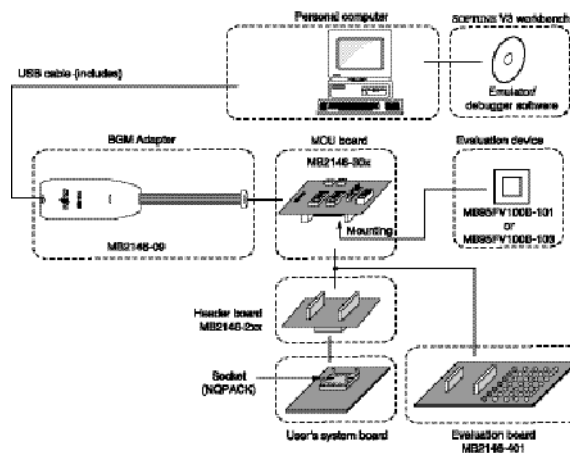

MB2146-401 Evaluation Board

# F<sup>2</sup>MC-8L Family Development Tools

## Features

- Supports debugging of source level (in assembly, C languages, a mixed indication)
- Simplified GUI operation using pull-down menu and buttons
- On-the-fly function (commands can be run during microcontroller execution and reference memory)
- Powerful real-time trace function
- Displays source codes, variables, register, memory and trace on multi windows
- Event trigger allows a wide range of conditions to be specified (x8)
- Sequential control in 8 conditions and 8 levels
- Performance-measurement function (measurement of execution speed between two points, iteration count measurement)
- Code coverage measurement function (program execution coverage rate measurement)
- Host I/F (standard accessories): RS-232C (max 115Kbps), LAN (10BASE-T)

## F<sup>2</sup>MC-8L Emulator Configuration

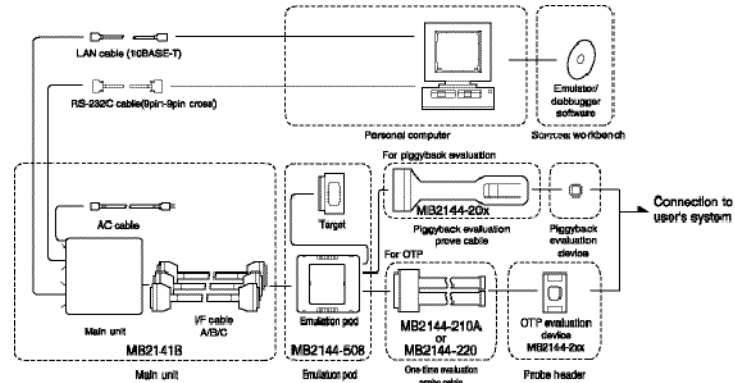

- Microcontroller operating voltage: +2.7V to +5.5V. The range (Max. and Min.) of the microcontroller operating voltage and operating frequency depends on each microcontroller. See the documentation including the data sheet, and check the range of microcontroller operating voltage and operating frequency.
- Compact development environment

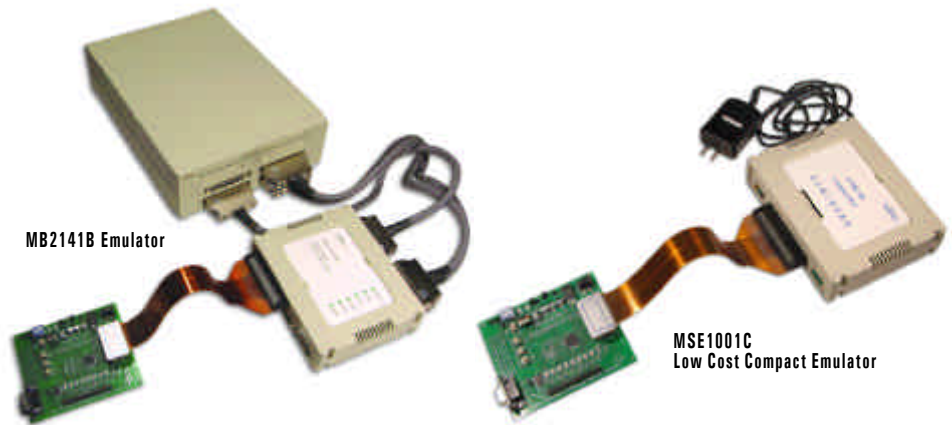

## SOFTUNE™ V3 Features of F2MC-8L/8FX Families

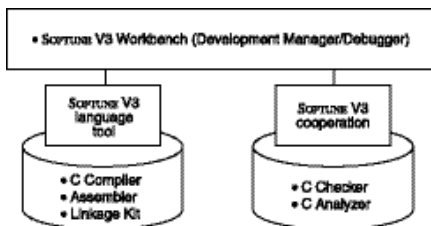

Software programming proceeds according to the "project file," which contains all the information needed for program development.

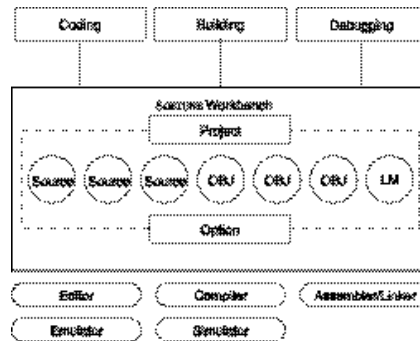

- The SOFTUNE™ V3 Workbench has integrated simulator, emulator and monitor debuggers.
- Integrates language and debugger tools, further facilitating the repeated process of coding, compiling and debugging.
- The C compiler's optimization feature provides high programming efficiency.

- Structured assembly language support
- Supports C language and assembly source debugging function
- Easy operation by multi-windows
- Integrated SOFTUNE™ V3 C Checker and SOFTUNE™ V3 C Analyzer quality tools

- Provides real-time debugging using real target-board evaluation tools + SOFTUNE™ V3 Workbench emulator/monitor debuggers
- Provides simulator debugger support for software debugging without target board
- Improves versatility and portability of software resources
- Compiler / C library: Conforms to ANSI standard

# F<sup>2</sup>MC-16LX Family Development Tools

## Features

- Supports debugging of source level (assembly and C languages, a mixed indication)
- Simplified graphic interface operation execution using pull-down menu and buttons
- On-the-fly function (commands can be run during microcontroller execution)
- Powerful real-time trace function
- Displays source codes, variables, register, memory and trace on multi-windows
- Event trigger allows a wide range of conditions to be specified (x8)
- Sequential control in 8 conditions and 8 levels
- Host I/F (standard accessories): RS-232C (115 Kbps), LAN (10BASE-T) and USB 1:1



## F<sup>2</sup>MC-16LX Emulator Configuration

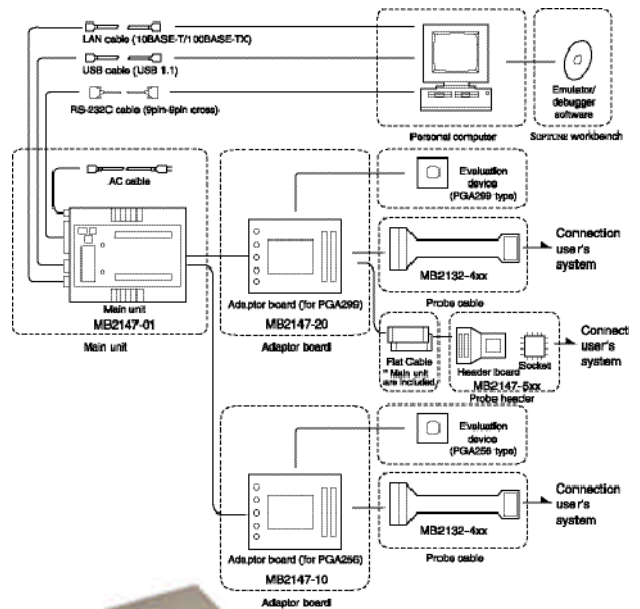

## SOFTUNE™ V3 Features of F<sup>2</sup>MC-16LX Family

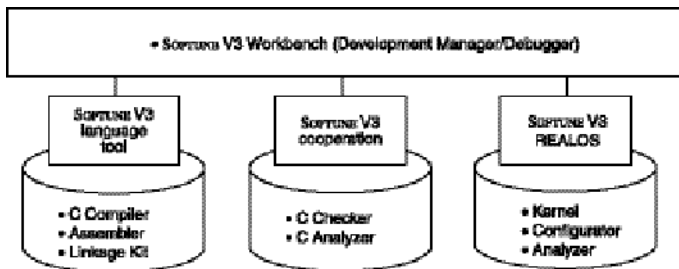

- Workbench integrated project manager and debugger modules
- Errors can be corrected on the fly, as they are discovered, and the resulting code can be debugged on the spot.
- A variety of tools to support C-language coding
- “C Checker” confirms code operation and “C Analyzer” analyzes the code’s structure.
- Includes tools such as Configurator and Analyzer to facilitate the use of REALOS™, which conforms to the μTRON specifications.
- Provides linkage with various CASE tools to support model-based development environment
- Integrates high-speed simulator, which is around 50 times faster than conventional simulators.
- High-speed simulator can be interfaced to external peripheral simulation mode

## F<sup>2</sup>MC-16LX Third Party OS Support

- OS CAN-the OSEK/VDX operating system from Vecor CANtech, Inc.
- Realtime operating system EUROS from EUROS Embedded Systems
- embOS, a small and efficient real time kernel from SEGGER Microcontroller Systems

# FR Family Development Tools

## Features

- DSU support: DSU3, DSU4
- Linear power supply voltage support from +2.7V to +5.5V
- Supports debugging of source level (assembly and C languages, a mixed indication)
- Simplified graphic interface operation execution using pull-down menu and buttons
- Real time trace function
- Displays source codes, variables, register, memory and trace on multi-windows
- Hardware break x5, software break x4096, code event x2, data event x2
- Operation cycle measurement function
- Host I/F (standard accessories): RS-232C (max 115 Kbps), LAN (10BASE-T, 100BASE-TX), USB 1.1

## FR Emulator Configuration

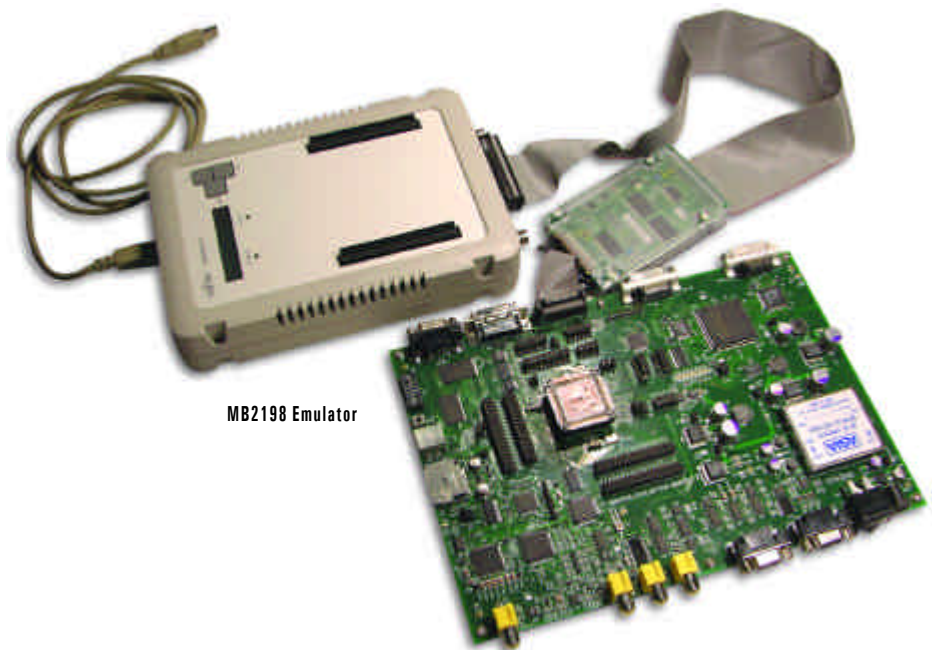
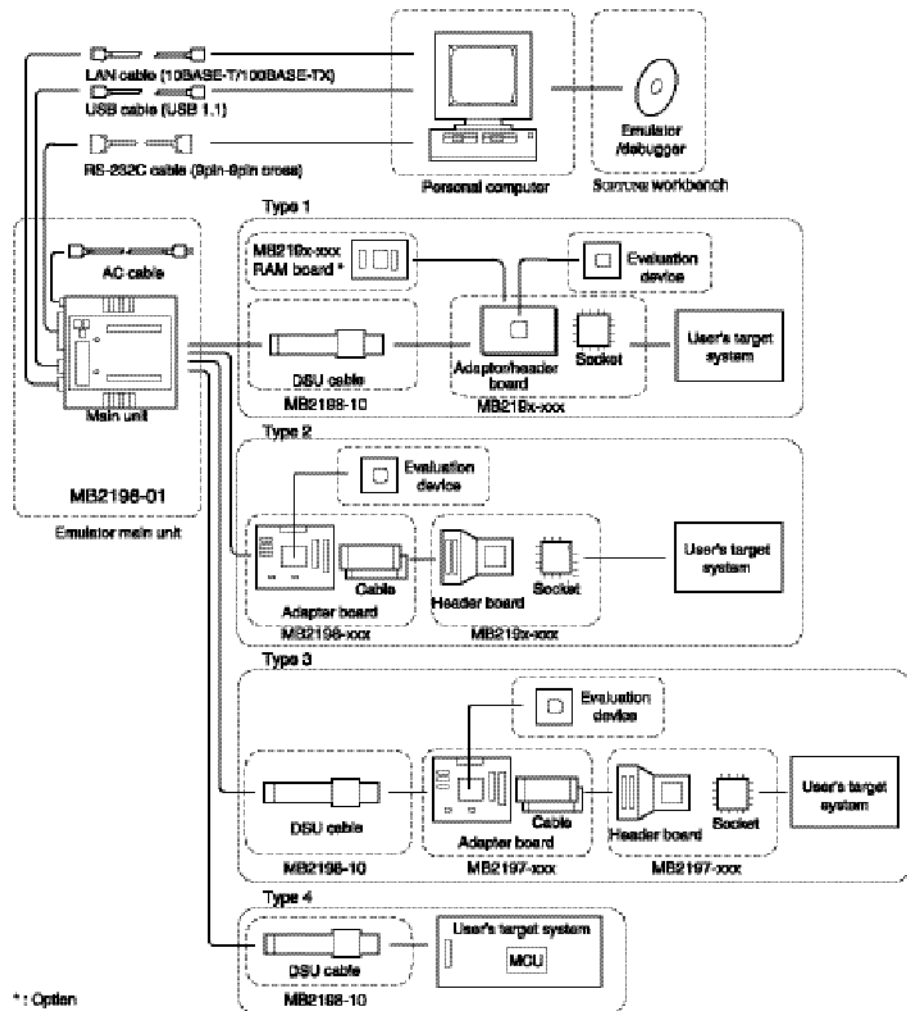

MB2198 Emulator

# FR Family Development Tools

## SOFTUNE™ V6 Features of 32-bit FR Family

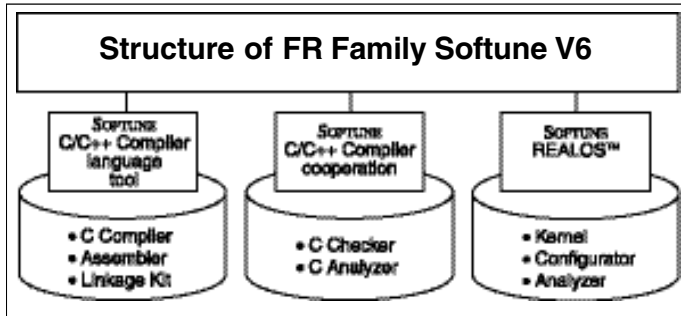

Comparison Table for REALOS™ Specifications

Name	3.0 Specifications	4.0 Specifications
Target CPU	FR	FR
Maximum number of task	32, 767	32, 767
Maximum number of priority levels	32	1,024
Scheduling method	Priority-base, event-driven type	Priority-base, event-driven type
Number of system calls	58	126
Complying specifications	μTRON 3.0 specifications	μTRON 4.0 specifications
Kernel coding	Assembly language	C and Assembly Languages
Application coding	C and Assembly Languages	C and Assembly Languages
Kernel size	About 2.7 KB (resident) to about 7.2 KB (maximum configuration)	About 9.5 KB (resident) to 43.3 KB (maximum configuration)

## Comprehensive Development Environment (SOFTUNE™ V6 Workbench)

- SOFTUNE™ V6 integrates language tools and debuggers into one to provide integrated development environment
- Supports C/C++ compiler, linker, librarian and hex converter
- Integrates simulator, emulator and monitor debuggers

## Supports the tools for quality, and performance analysis of source programs

- SOFTUNE™ C/C++ Checker  
Quality tool for checking the source code form of a source to display the information to enhance portability and maintainability.
- SOFTUNE™ C/C++ Analyzer  
Analyzes the source description; displaying the overall hierarchical organization. Effective for maintainability and portability.

## Supports Embedded Real-time OS

- Conforms to μTRON Specifications known as the Japanese industry standard
  - μTRON3.0 Specifications Softune REALOS/FR
  - μTRON4.0 Specifications Softune REALOS/FR Spec.4

## Robust support for development using REALOS

- REALOS™ Configurator: Easy-to-configure parameters for kernel generation REALOS™ debugger
- Supports the in-line-expansion options for C compiler REALOS™ system calls
- REALOS™ Analyzer: Analyzes the transition of task states to visually display the results

## FR Third party OS and Network Protocol Support

- μC/OS-11, μC/TCP/IP support by Micrium, Inc.
- Realtime Operating System EUROS. Support for TCP/IP, CAN-BUS, CANopen protocols
- A small and efficient real-time kernel embOS support
- OSCAN - the OSEK/VDX operating system. Support for CAN, LIN, and FlexRay protocol drivers

# Third Party Support

## Monitor Debugger Support:

Accemic GmbH & Co. KG



Accemic provides cost-effective, leading edge software development tools for embedded systems. Accemic MDE is a source level and symbolic debugger for Fujitsu 16LX and FRseries microcontrollers.

The software offers outstanding feature such as:

- single chip debugging without the need of external RAM
- Multiprocessor debugging via CAN
- Visual control of the internal MCU periphery

Accemic GmbH & Co. KG, Wuerzstr. 1, 81371 Munich, Germany  
Tel: +49 89 680934-0, Fax:+49 89 680934-27, info@accemic.com, www.accemic.com

## Operating System, CAN bootloader and LIN Drivers:

Vector CANtech, Inc



Vector is the leading manufacturer of software tools and software components for networking in electronic systems based on CAN, LIN, MOST or FlexRay. osCAN for the 16LX and FR family microcontrollers is the first choice for embedded applications requiring a small, stable and efficient kernel. osCAN is fully compliant with the OSEK/VDX standard.

Vector CANtech, Inc. USA, 39500 Orchard Hill Place, Suite 550, Novi, Michigan 48375,  
Tel: (248)449-9290, Fax:(248)449-9704, info@vector-cantech.com

## µC/OS-II, µC/TCP/IP Micrium, Inc. USA



µC/OS-II supports Fujitsu FR family microcontrollers, The Real-Time Kernel is a highly portable, scalable, preemptive real-time, multitasking kernel (RTOS). µC/TCP-IP is Micrium's implementation of the popular networking protocol. It is a portable, ROMable, modular networking protocol that supports Fujitsu's 32bit FR microcontrollers.

Micrium, Inc. 949 Crestview Circle, Weston, FL 33327 USA  
Tel: (954) 217-2036, Fas: (954) 217-2037, www.micrium.com

## Parallel Programmers

BP Microsystems, USA



BP Micro offers a full line of MCU device programmers, which include Universal Programmers, Concurrent Programming Systems®, and Fine-Pitch Automated Programming Systems, designed to meet all of your programming requirements. Our industry-leading technologies provide customers with the most flexible, value-focused programmers designed to lower the cost of programming. From the lowest to the highest in programming volume, BP Microsystems has a product that will fit your need and will grow as your business grows.

BP Microsystems, 1000 North Post Oak Road, Suite 225, Houston, Texas 77055 USA,  
Tel: 713-688-4600 or Tel: or 800-225-2102 (US only), Fax:713-688-0920,  
web@bpmicro.com

## Serial Programmer

Yokogawa Digital Computer Corporation



NETIMPRESS is a Universal Flash high-speed serial programmer for wide-range of Fujitsu Flash MPU/MCU including CAN Bus Controller, is suit for Development, production and support field. Also we release the common CAN programming protocol called U-COP in near future with semiconductor manufacture's support. We promises to expand the specific library for Fujitsu including CAN Bus Controller. Please visit our web in details.

Yokogawa Corp of America, YCA ICE Division, 1731 Technology Drive, Suite 690, San Jose, CA 95110, Tel: (408) 392-0540, Fax:(408) 392-0541, www.advice-plus.com/about/

## Programming Service

Source Electronics, USA



Source Electronics provides state-of-the-art programming, labeling, and taping/reeling support with excellent built-in quality controls and technical support. Source Electronics Corporation's comprehensive programming facilities utilize many types of sophisticated automated equipment. Source was one of the first companies in the electronics industry to become ISO 9002 certified (1994) and has now received QS9000 certification. In addition, Source operates in an ESD Class "0" environment - the highest level of protection for static-sensitive devices. Source Electronics has facilities located in New Hampshire, California, Mexico, and Brazil.

Corporate Headquarters, Source Electronics Corporation, 26 Clinton Drive, Hollis, NH 03049, info@sourcee.com, www.sourcee.com

Fremont Facility, Source Electronics Corporation, 47470 Seabridge Drive, Fremont, CA 94538, Email: directions@fremont.sourcee.com

## FUJITSU MICROELECTRONICS AMERICA, INC.

1250 E. Arques Avenue, MS333, Sunnyvale, CA 94088-3470

Tel: (800) 866-8608 Fax: (408) 737-5999

http://us.fujitsu.com/micro, Email: inquiry@fma.fujitsu.com

© 2006 Fujitsu Microelectronics America, Inc.  
All company and product names are trademarks or registered trademarks of their respective owners.

Printed in the U.S.A. MCU-FS-21151-3/2006