

ASSP

Dual Serial Input PLL Frequency Synthesizer

MB15F02L

■ DESCRIPTION

The Fujitsu MB15F02L is a serial input Phase Locked Loop (PLL) frequency synthesizer with a 1.2 GHz and a 250 MHz prescalers. A 64/65 or a 128/129 for the 1.2 GHz prescaler, and a 16/17 or a 32/33 for 250 MHz prescaler can be selected that enables pulse swallow operation.

The latest BiCMOS process technology is used, resultantly a supply current is limited as low as 4.0 mA typ. at a supply voltage of 3.0 V.

Furthermore, a super charger circuit is included to provide a fast tuning as well as low noise performance. As a result of this, MB15F02L is ideally suitable for digital mobile communications, such as GSM (Global System for Mobile Communications).

■ FEATURES

- High frequency operation RF synthesizer: 1.2 GHz max. / IF synthesizer: 250 MHz max.
- Low power supply voltage: $V_{CC} = 2.7$ to 3.6 V
- Very Low power supply current : $I_{CC} = 4.0$ mA typ. ($V_{CC} = 3$ V)
- Power saving function : Supply current at power saving mode Typ.0.1 μ A ($V_{CC} = 3$ V), Max.10 μ A ($I_{PS1} = I_{PS2}$)
- Dual modulus prescaler : 1.2 GHz prescaler (64/65,128/129) , 250 MHz prescaler (16/17,32/33)
- Serial input 14-bit programmable reference divider: $R = 5$ to 16,383
- Serial input 18-bit programmable divider consisting of:
 - Binary 7-bit swallow counter: 0 to 127
 - Binary 11-bit programmable counter: 5 to 2,047
- On-chip high performance charge pump circuit and phase comparator, achieving high-speed lock-up and low phase noise
- On-chip phase control for phase comparator
- Wide operating temperature: $T_a = -40$ to 85°C

■ PACKAGES

16-pin, Plastic SSOP

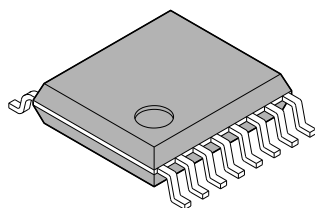

(FPT-16P-M05)

16-pin, Plastic BCC

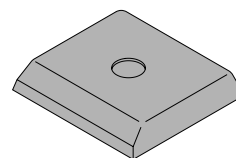

(LCC-16P-M03)

MB15F02L

■ PIN ASSIGNMENTS

SSOP-16 pin

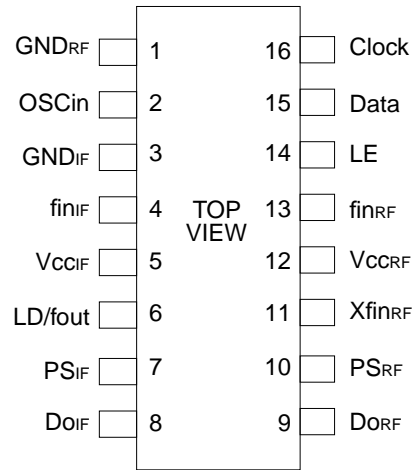

(FPT-16P-M05)

BCC-16 pin

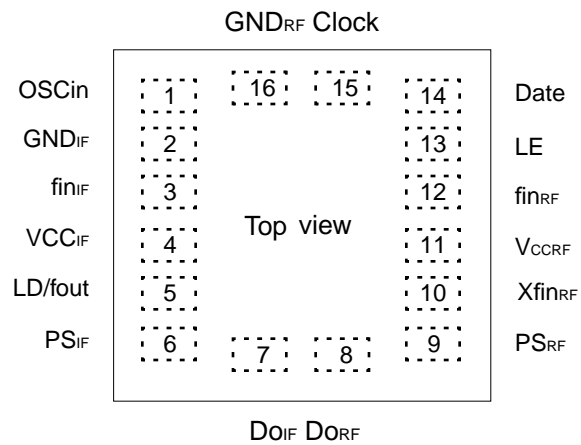

(LCC-16P-M03)

■ PIN DESCRIPTIONS

Pin no.		Pin name	I/O	Descriptions
SSOP	BCC			
1	16	GND _{RF}	–	Ground for RF-PLL section.
2	1	OSC _{in}	I	The programmable reference divider input. TCXO should be connected with a AC coupling capacitor.
3	2	GND _{IF}	–	Ground for the IF-PLL section.
4	3	fin _{IF}	I	Prescaler input pin for the IF-PLL. The connection with VCO should be AC coupling.
5	4	V _{CCIF}	–	Power supply voltage input pin for the IF-PLL section.
6	5	LD/fout	O	Lock detect signal output (LD) / phase comparator monitoring output (fout) The output signal is selected by a LDS bit in a serial data. LDS bit = "H" ; outputs fout signal LDS bit = "L" ; outputs LD signal
7	6	PS _{IF}	I	Power saving mode control for the IF-PLL section. This pin must be set at "L" Power-ON. (Open is prohibited.) PS _{IF} = "H" ; Normal mode PS _{IF} = "L" ; Power saving mode
8	7	DO _{IF}	O	Charge pump output for the IF-PLL section. Phase characteristics of the phase detector can be reversed by FC-bit.
9	8	DO _{RF}	O	Charge pump output for the RF-PLL section. Phase characteristics of the phase detector can be reversed by FC-bit.
10	9	PS _{RF}	I	Power saving mode control for the RF-PLL section. This pin must be set at "L" Power-ON. (Open is prohibited.) PS _{RF} = "H" ; Normal mode PS _{RF} = "L" ; Power saving mode
11	10	Xfin _{RF}	I	Prescaler complimentary input for the RF-PLL section. This pin should be grounded via a capacitor.
12	11	V _{CCRF}	–	Power supply voltage input pin for the RF-PLL section, the shift register and the oscillator input buffer. When power is OFF, latched data of RF-PLL is cancelled.
13	12	fin _{RF}	I	Prescaler input pin for the RF-PLL. The connection with VCO should be AC coupling.
14	13	LE	I	Load enable signal input (with the schmitt trigger circuit.) When LE is "H", data in the shift register is transferred to the corresponding latch according to the control bit in a serial data.
15	14	Data	I	Serial data input (with the schmitt trigger circuit.) A data is transferred to the corresponding latch (IF-ref counter, IF-prog. counter, RF-ref. counter, RF-prog. counter) according to the control bit in a serial data.
16	15	Clock	I	Clock input for the 23-bit shift register (with the schmitt trigger circuit.) One bit data is shifted into the shift register on a rising edge of the clock.

MB15F02L

■ BLOCK DIAGRAM

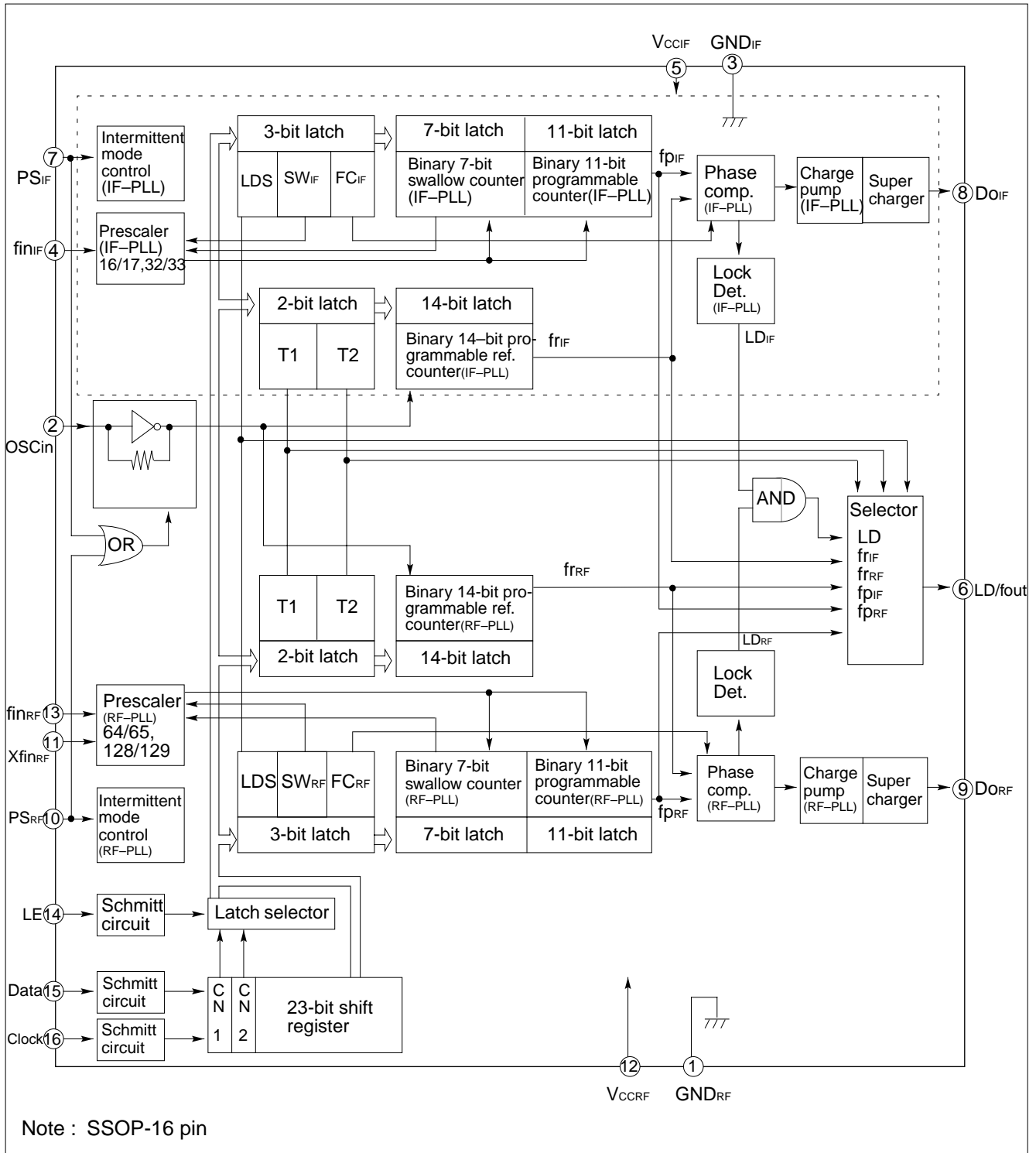

■ ABSOLUTE MAXIMUM RATINGS (See WARNING)

Parameter	Symbol	Rating		Unit	Remark
		Min.	Max.		
Power supply voltage	V_{CC}	-0.5	+4.0	V	
Input voltage	V_I	-0.5	$V_{CC} + 0.5$	V	
Output voltage	V_O	-0.5	$V_{CC} + 0.5$	V	
Output current	I_O	-10	+10	mA	Except Do output
	I_{DO}	-25	+25	mA	Do output
Storage temperature	T_{STG}	-55	+125	°C	

WARNING: Semiconductor devices can be permanently damaged by application of stress (voltage, current, temperature, etc.) in excess of absolute maximum ratings. Do not exceed these ratings.

■ RECOMMENDED OPERATING CONDITIONS

Parameter	Symbol	Value			Unit	Remark
		Min.	Typ.	Max.		
Power supply voltage	V_{CC}	2.7	3.0	3.6	V	
Input voltage	V_I	GND	-	V_{CC}	V	
Operating temperature	T_a	-40	-	+85	°C	

WARNING: Recommended operating conditions are normal operating ranges for the semiconductor device. All the device's electrical characteristics are warranted when operated within these ranges.

Always use semiconductor devices within the recommended operating conditions. Operation outside these ranges may adversely affect reliability and could result in device failure.

No warranty is made with respect to uses, operating conditions, or combinations not represented on the data sheet. Users considering application outside the listed conditions are advised to contact their FUJITSU representative beforehand.

Handling Precautions

- This device should be transported and stored in anti-static containers.
- This is a static-sensitive device; take proper anti-ESD precautions. Ensure that personnel and equipment are properly grounded. Cover workbenches with grounded conductive mats.
- Always turn the power supply off before inserting or removing the device from its socket.
- Protect leads with a conductive sheet when handling or transporting PC boards with devices.

MB15F02L

■ ELECTRICAL CHARACTERISTICS

($V_{CC} = 2.7$ to 3.6 V, $T_a = -40$ to $+85^\circ\text{C}$)

Parameter	Symbol	Condition	Value			Unit	
			Min.	Typ.	Max.		
Power supply current	I_{CCIF}^{*1}	$f_{inIF} = 250$ MHz, $f_{osc} = 12$ MHz	–	1.5	–	mA	
	I_{CCRF}^{*2}	$f_{inRF} = 1200$ MHz, $f_{osc} = 12$ MHz	–	2.5	–		
Power saving current	I_{psIF}	V_{CCIF} current at $PS_{IF} = \text{“L”}$	–	0.1^{*3}	10	μA	
	I_{psRF}	V_{CCRF} current at $PS_{IF/RF} = \text{“L”}$	–	0.1^{*3}	10		
Operating frequency	f_{inIF}^{*4}	f_{inIF}	IF-PLL	50	–	250	MHz
	f_{inRF}^{*4}	f_{inRF}	RF-PLL	100	–	1200	
	OSCin	f_{OSC}	–	3	–	40	
Input sensitivity	f_{inIF}	V_{finIF}	IF-PLL, $50\ \Omega$ termination	–10	–	+2	dBm
	f_{inRF}	V_{finRF}	RF-PLL, $50\ \Omega$ termination	–10	–	+2	
	OSCin	V_{OSC}	–	0.5	–	V_{CC}	Vp-p
Input voltage	Data, Clock, LE	V_{IH}	Schmitt trigger input	$V_{CC} \times 0.7 + 0.4$	–	–	V
		V_{IL}	Schmitt trigger input	–	–	$V_{CC} \times 0.3 - 0.4$	
	PS_{IF} , PS_{RF}	V_{IH}	–	$V_{CC} \times 0.7$	–	–	V
		V_{IL}	–	–	–	$V_{CC} \times 0.3$	
Input current	Data, Clock, LE, PS_{IF} , PS_{RF}	I_{IH}^{*5}	–	–1.0	–	+1.0	μA
		I_{IL}^{*5}	–	–1.0	–	+1.0	
	OSCin	I_{IH}	–	0	–	+100	μA
		I_{IL}^{*5}	–	–100	–	0	
Output voltage	LD/fout	V_{OH}	$V_{CC} = 3.0$ V, $I_{OH} = -1.0$ mA	$V_{CC} - 0.4$	–	–	V
		V_{OL}	$V_{CC} = 3.0$ V, $I_{OL} = 1.0$ mA	–	–	0.4	
	DO_{IF} , DO_{RF}	V_{DOH}	$V_{CC} = 3.0$ V, $I_{DOH} = -1.0$ mA	$V_{CC} - 0.4$	–	–	V
		V_{DOL}	$V_{CC} = 3.0$ V, $I_{DOL} = 1.0$ mA	–	–	0.4	
High impedance cutoff current	DO_{IF} , DO_{RF}	I_{OFF}	$V_{CC} = 3.0$ V, $V_{OFF} = \text{GND to } V_{CC}$	–	–	3.0	nA
Output current	LD/fout	I_{OH}^{*5}	$V_{CC} = 3.0$ V	–1.0	–	–	mA
		I_{OL}	$V_{CC} = 3.0$ V	–	–	1.0	
	DO_{IF} , DO_{RF}	I_{DOH}^{*5}	$V_{CC} = 3.0$ V, $V_{DOH} = 2.0$ V, $T_a = 25^\circ\text{C}$	–11	–	–6	mA
		I_{DOL}	$V_{CC} = 3.0$ V, $V_{DOL} = 1.0$ V, $T_a = 25^\circ\text{C}$	8	–	15	

*1: Conditions ; $V_{CCIF} = 3$ V, $T_a = 25^\circ\text{C}$, in locking state.

*2: Conditions ; $V_{CCRF} = 3$ V, $T_a = 25^\circ\text{C}$, in locking state.

*3: $f_{osc} = 12.8$ MHz , $V_{CC} = 3.0$ V, $T_a = 25^\circ\text{C}$

*4: AC coupling with a 1000 pF capacitor connected.

*5: The symbol “–” (minus) means direction of current flow.

Table4. Binary 11-bit Programmable Counter Data Setting

Divide ratio (N)	N 11	N 10	N 9	N 8	N 7	N 6	N 5	N 4	N 3	N 2	N 1
5	0	0	0	0	0	0	0	0	1	0	1
6	0	0	0	0	0	0	0	0	1	1	0
·	·	·	·	·	·	·	·	·	·	·	·
2047	1	1	1	1	1	1	1	1	1	1	1

Note: Divide ratio less than 5 is prohibited.

Table5. Binary 7-bit Swallow Counter Data Setting

Divide ratio (A)	A 7	A 6	A 5	A 4	A 3	A 2	A 1
0	0	0	0	0	0	0	0
1	0	0	0	0	0	0	1
·	·	·	·	·	·	·	·
127	1	1	1	1	1	1	1

Note: Divide ratio (A) range = 0 to 127

Table6. Prescaler Data Setting

		SW = "H"	SW = "L"
Prescaler divide ratio	IF-PLL	16/17	32/33
	RF-PLL	64/65	128/129

Table7. Phase Comparator Phase Switching Data Setting

	FC _{IF,RF} = H	FC _{IF,RF} = L
	DO _{IF,RF}	
fr > fp	H	L
fr = fp	Z	Z
fr < fp	L	H
VCO polarity	(1)	(2)

Note: • Z = High-impedance
 • Depending upon the VCO and LPF polarity, FC bit should be set.

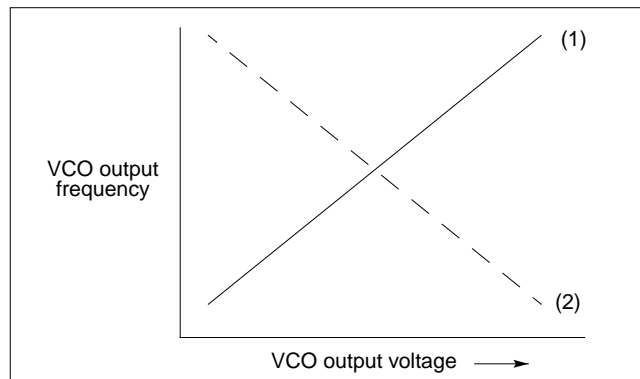

Table8. LD/fout Output Select Data Setting

LDS	LD/fout output signal
H	fout (f _{rIF/RF} , f _{pIF/RF}) signals
L	LD signal

MB15F02L

3. Power Saving Mode (Intermittent Mode Control Circuit)

Setting a PS_{IF(RF)} pin to Low, IF-PLL (RF-PLL) enters into power saving mode resultant current consumption can be limited to 10 μ A (typ.). Setting PS pin to High, power saving mode is released so that the device works normally. In addition, the intermittent operation control circuit is included which helps smooth start up from stand by mode. In general, the power consumption can be saved by the intermittent operation that powering down or waking up the synthesizer. Such case, if the PLL is powered up uncontrolled, the resulting phase comparator output signal is unpredictable due to an undefined phase relation between reference frequency (fr) and comparison frequency (fp) and may in the worst case take longer time for lock up of the loop.

To prevent this, the intermittent operation control circuit enforces a limited error signal output of the phase detector during power up. Thus keeping the loop locked.

PS pin must be set "L" at Power-ON.

Allow 1 μ s after frequency stabilization on power-up for exiting the power saving mode (PS: L to H)

Serial data can be entered during the power saving mode.

During the power saving mode, the corresponding section except for indispensable circuit for the power saving function stops working, then current consumption is reduced to 10 μ A per one PLL section.

At that time, the Do and LD become the same state as when a loop is locking. That is, the Do becomes high impedance.

A VCO control voltage is naturally kept at the locking voltage which defined by a LPF's time constant. As a result of this, VCO's frequency is kept at the locking frequency.

PS _{IF}	PS _{RF}	IF-PLL counters	RF-PLL counters	OSC input buffer
L	L	OFF	OFF	OFF
H	L	ON	OFF	ON
L	H	OFF	ON	ON
H	H	ON	ON	ON

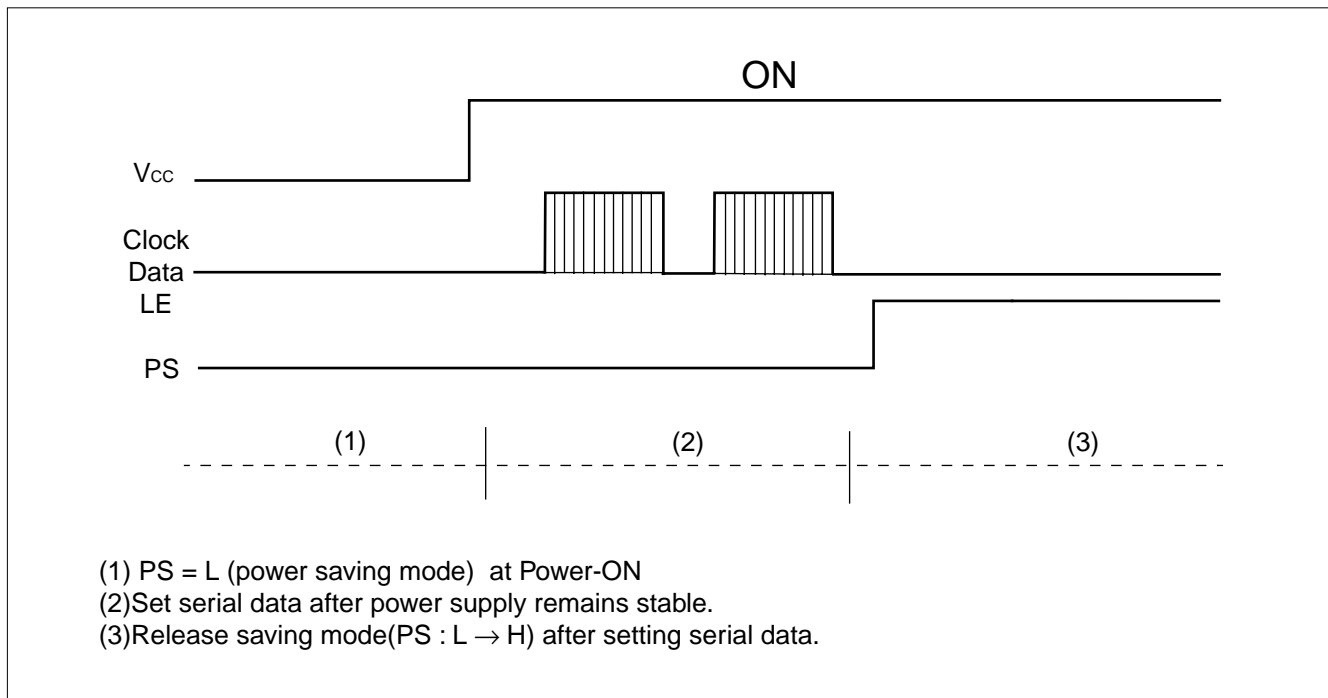

- (1) PS = L (power saving mode) at Power-ON
- (2) Set serial data after power supply remains stable.
- (3) Release saving mode (PS : L → H) after setting serial data.

4. Serial Data Input Timing

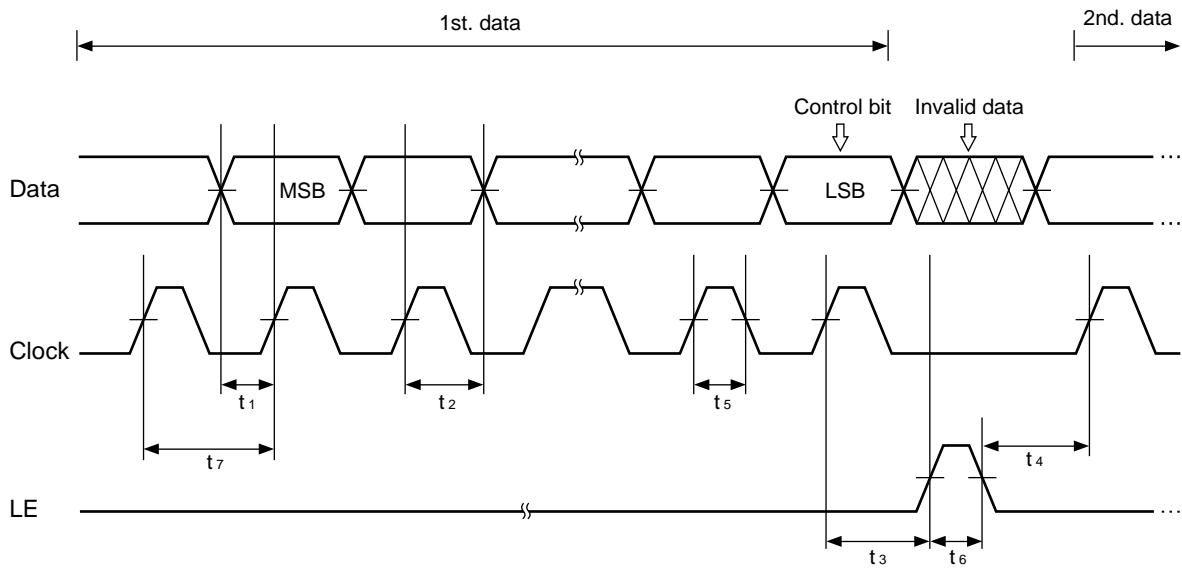

On rising edge of the clock, one bit of the data is transferred into the shift register.

Parameter	Min.	Typ.	Max.	Unit
t1	20	–	–	ns
t2	20	–	–	ns
t3	30	–	–	ns
t4	20	–	–	ns

Parameter	Min.	Typ.	Max.	Unit
t5	30	–	–	ns
t6	100	–	–	ns
t7	100	–	–	ns

MB15F02L

■ PHASE DETECTOR OUTPUT WAVEFORM

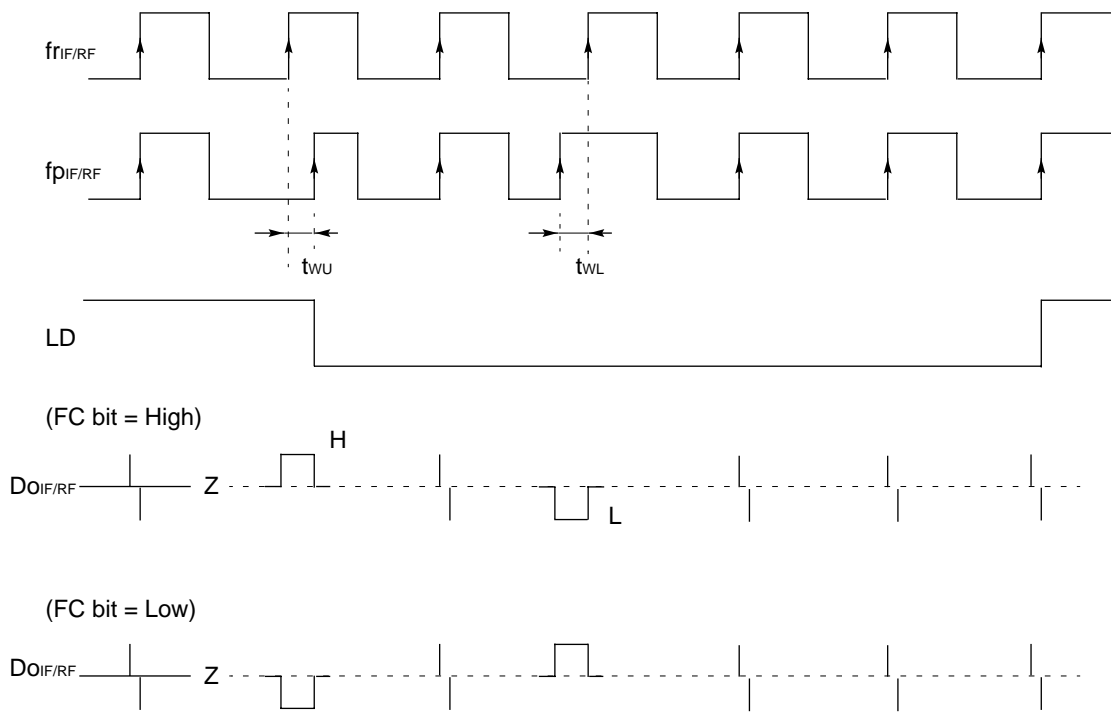

LD Output Logic Table

IF-PLL section	RF-PLL section	LD output
Locking state / Power saving state	Locking state / Power saving state	H
Locking state / Power saving state	Unlocking state	L
Unlocking state	Locking state / Power saving state	L
Unlocking state	Unlocking state	L

- Note:
- Phase error detection range = -2π to $+2\pi$
 - Pulses on DoIF/RF signals are output to prevent dead zone.
 - LD output becomes low when phase error is t_{WU} or more.
 - LD output becomes high when phase error is t_{WL} or less and continues to be so for three cycles or more.
 - t_{WU} and t_{WL} depend on OSCin input frequency as follows.
 $t_{WU} \geq 4/f_{osc}$: i.e. $t_{WU} \geq 312.5$ ns when $f_{osc} = 12.8$ MHz
 $t_{WL} \leq 8/f_{osc}$: i.e. $t_{WL} \leq 625.0$ ns when $f_{osc} = 12.8$ MHz

■ TEST CIRCUIT (fin, OSC_{IN} Input Sensitivity Test)

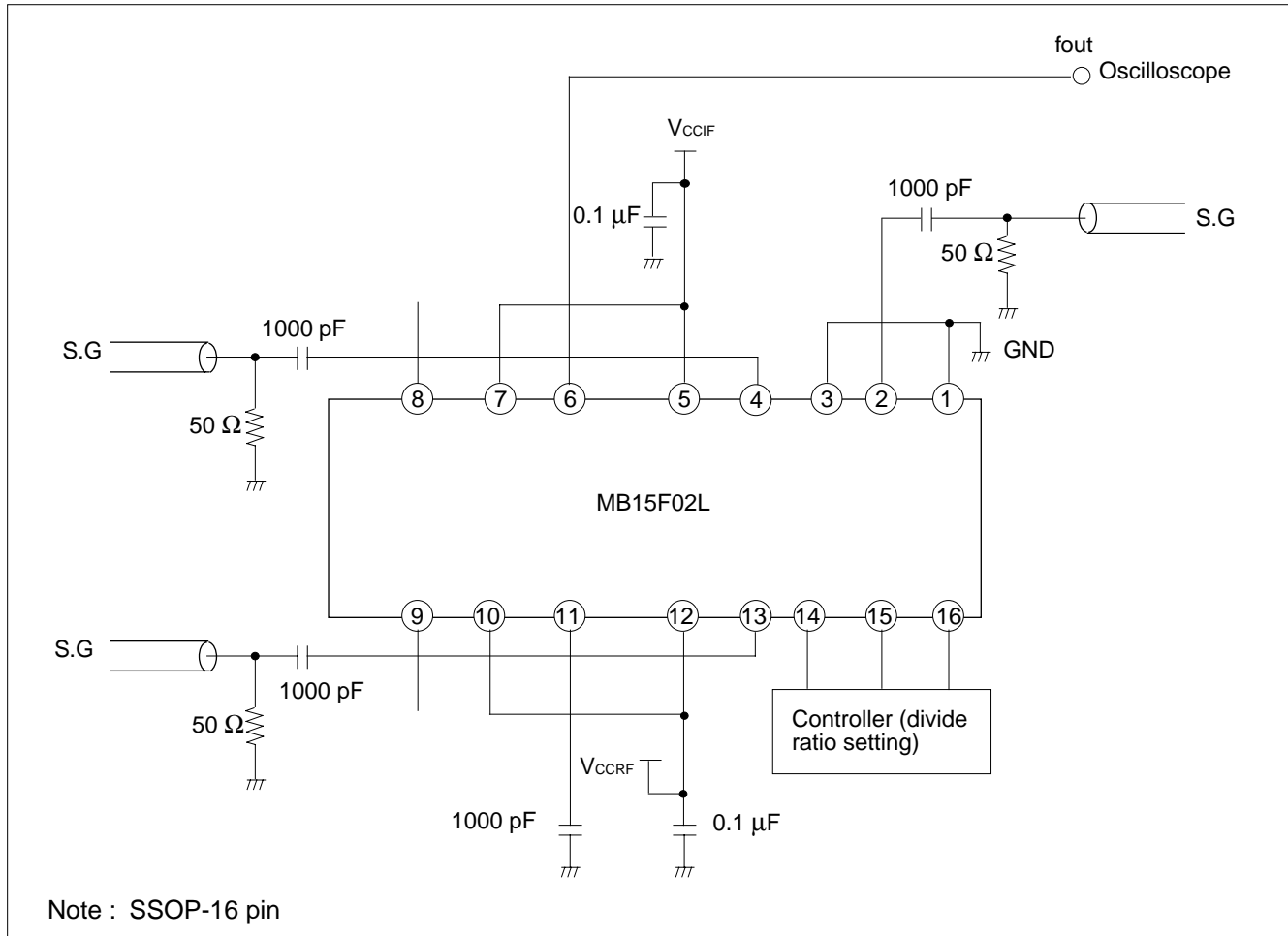

MB15F02L

TYPICAL CHARACTERISTICS

1. fin Input Sensitivity

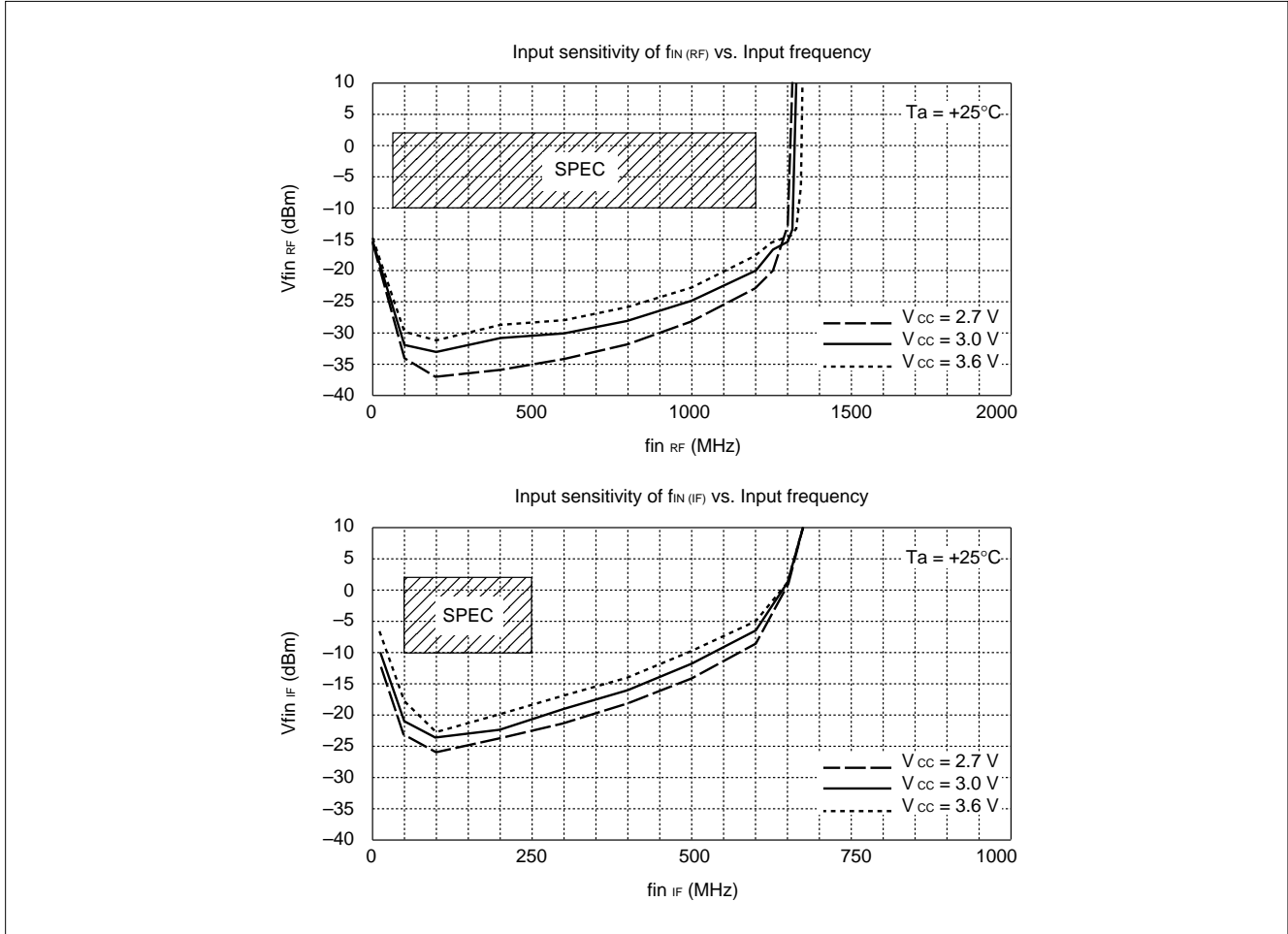

2. OSCin Input Sensitivity

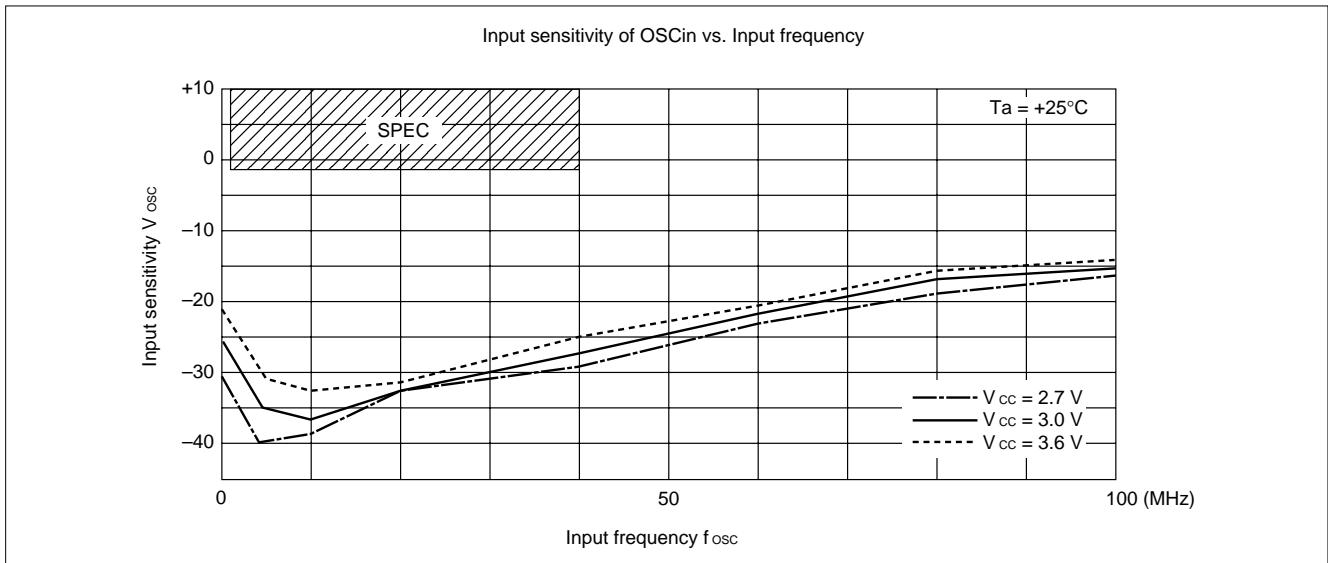

3. D_{ORF} Output Current

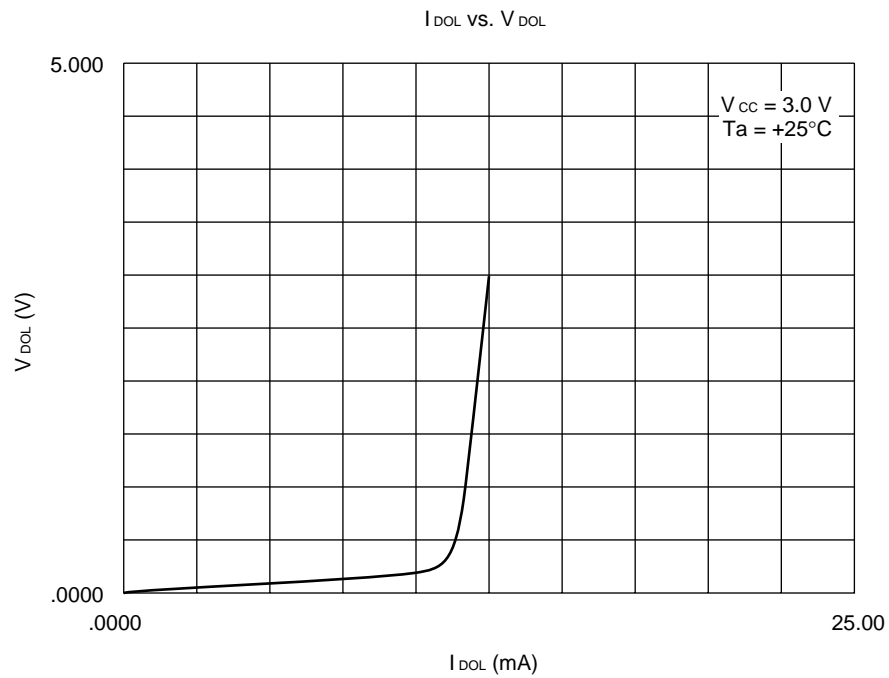
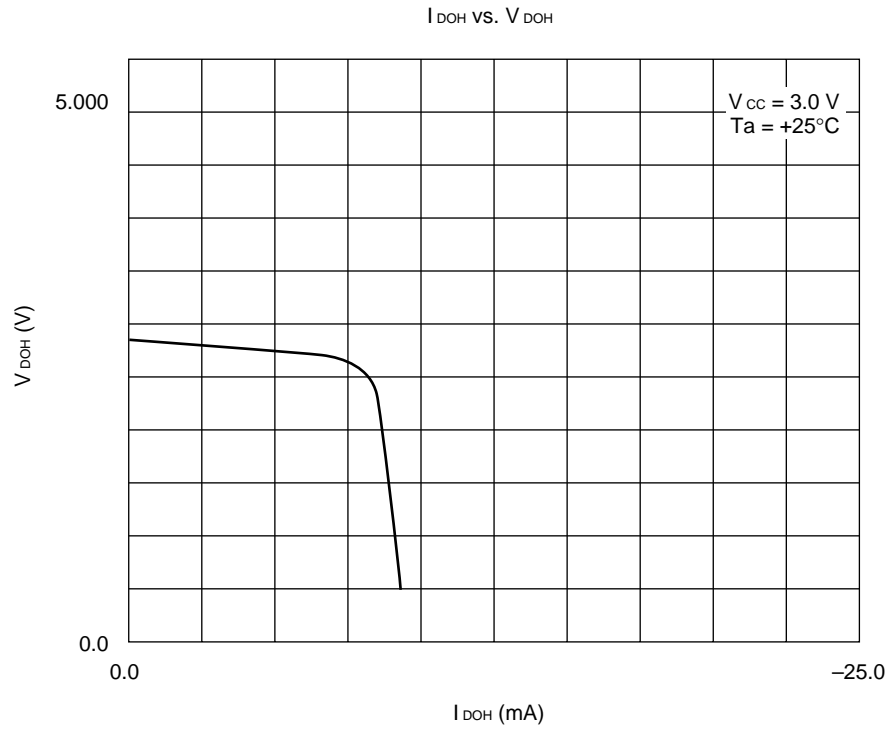

MB15F02L

4. I_{DOIF} Output Current

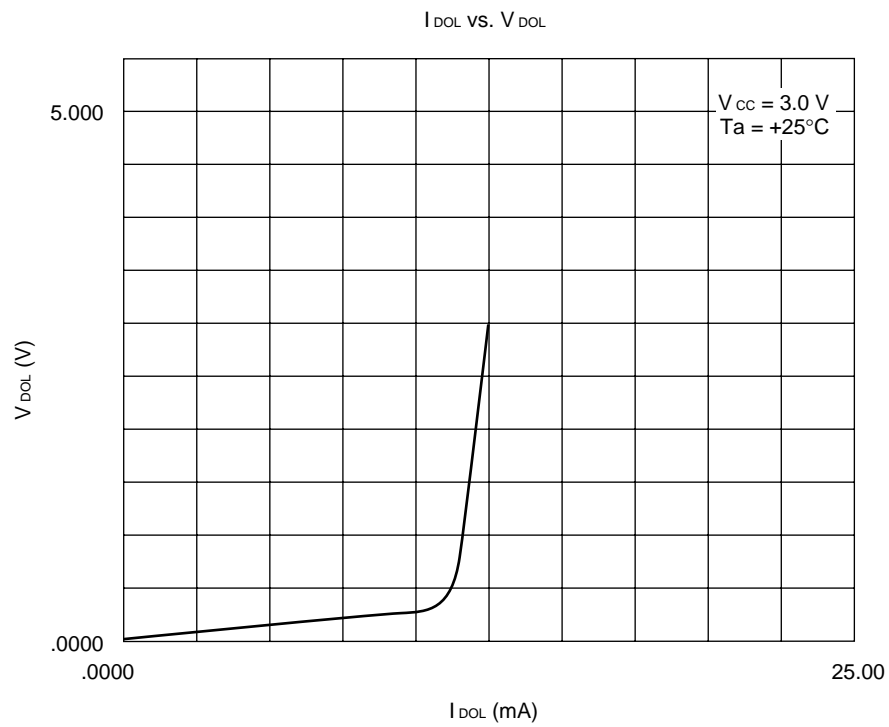
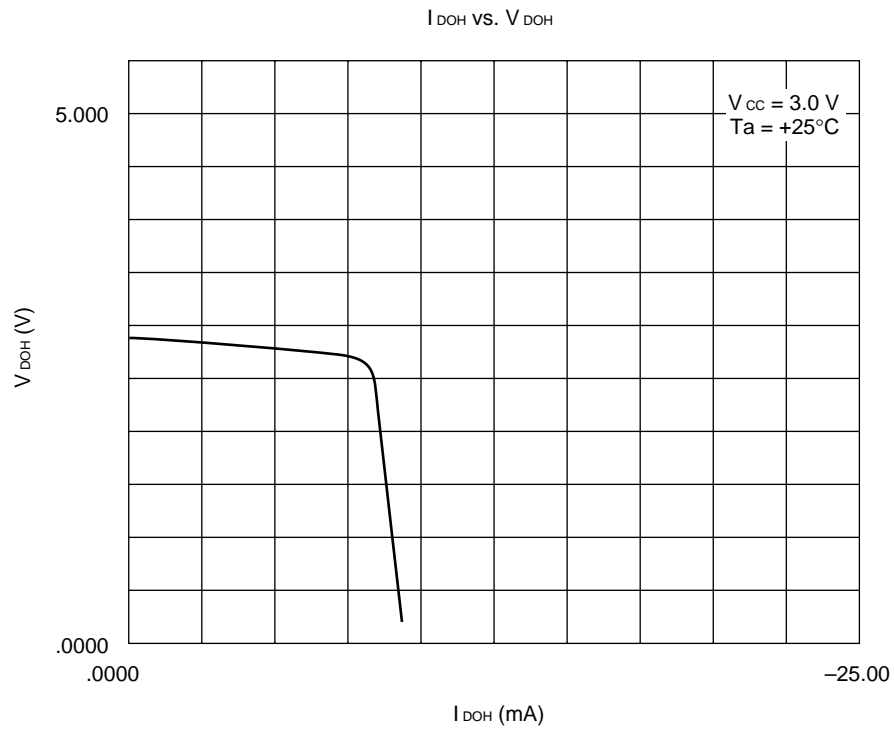

5. fin Input Impedance

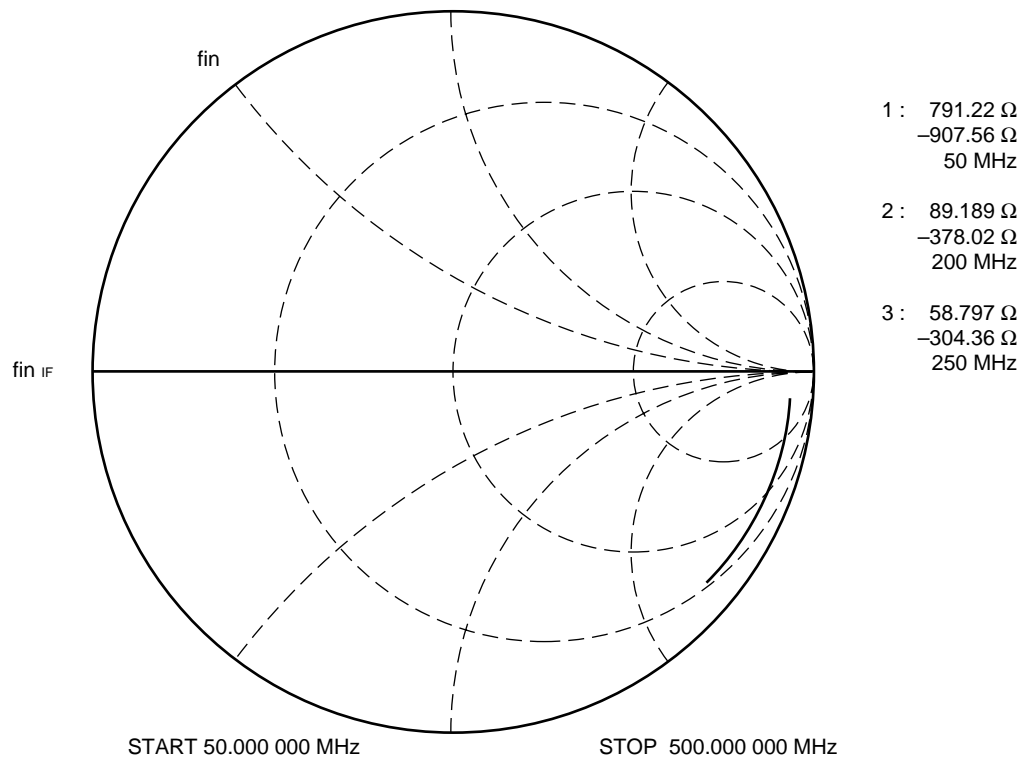
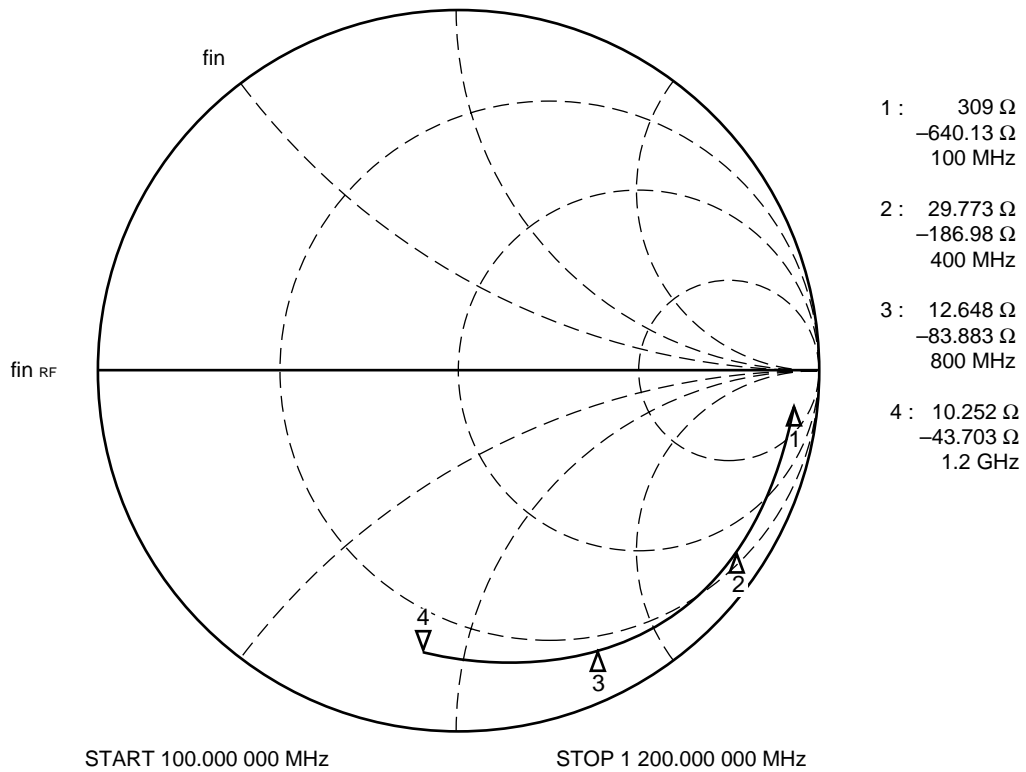

MB15F02L

6. OSC_{IN} Input Impedance

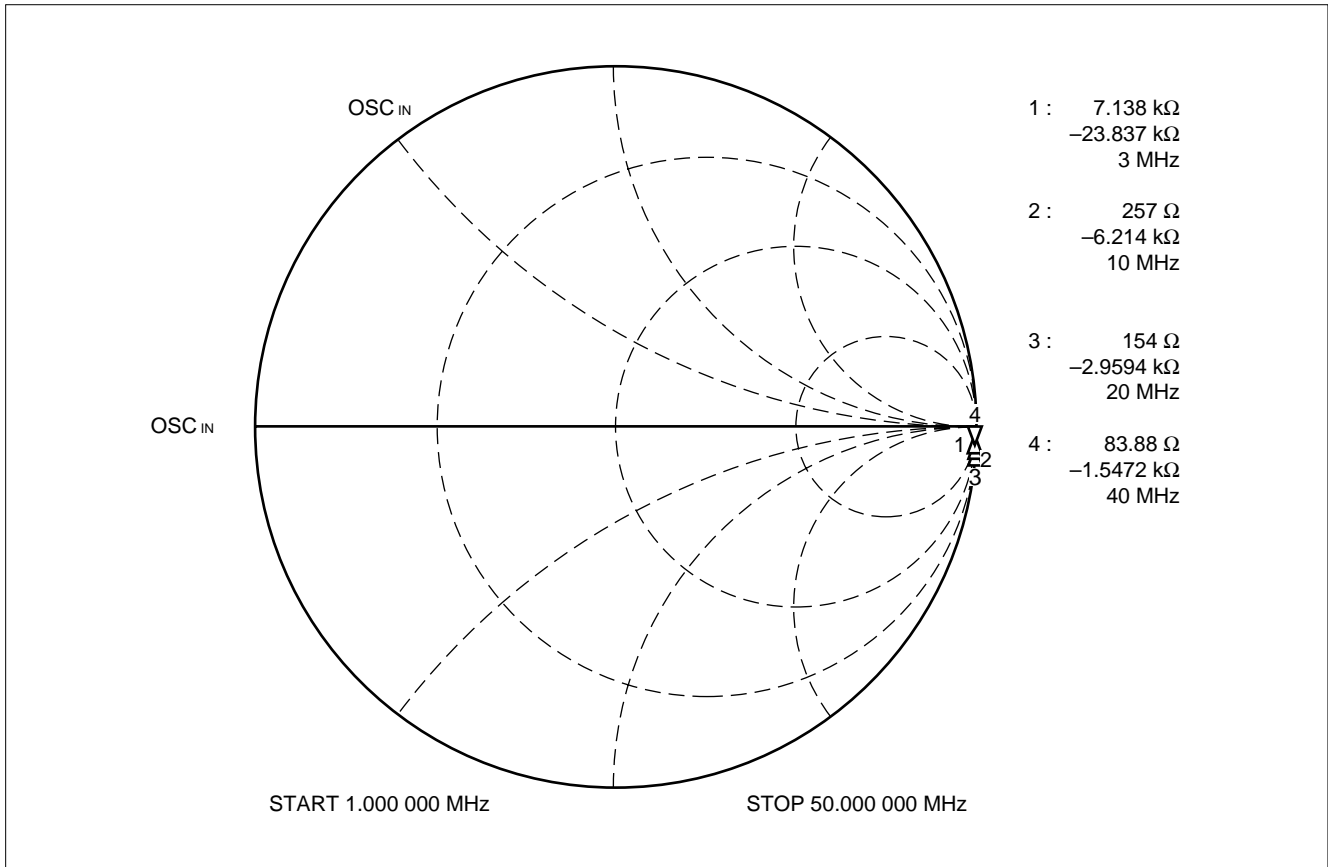

MB15F02L

APPLICATION EXAMPLE

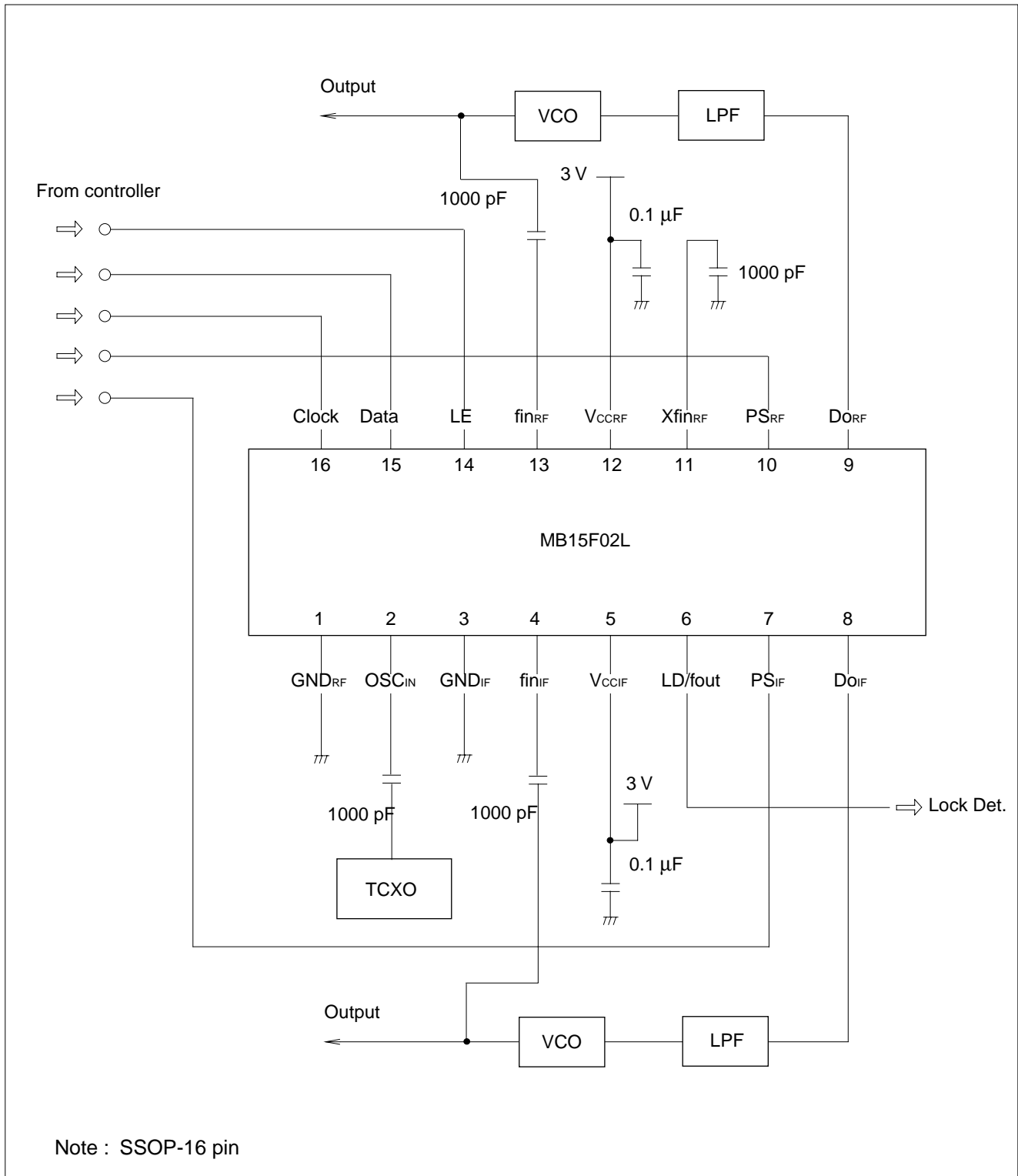

■ ORDERING INFORMATION

Part number	Package	Remarks
MB15F02LPFV1	16 pin, Plastic SSOP (FPT-16P-M05)	
MB15F02LPV	16 pin, Plastic BCC (LCC-16P-M03)	

MB15F02L

■ PACKAGE DIMENSIONS

16 pins, Plastic SSOP
(FPT-16P-M05)

*: These dimensions do not include resin protrusion.

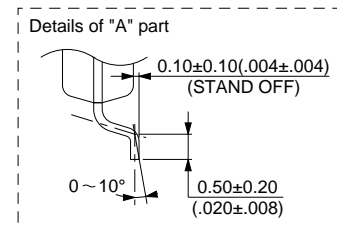
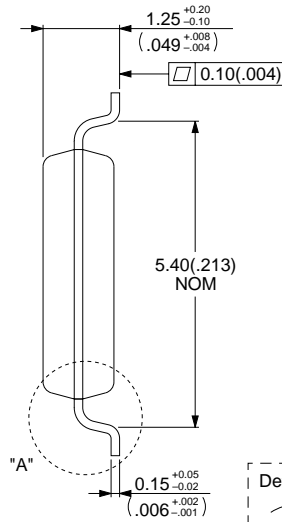
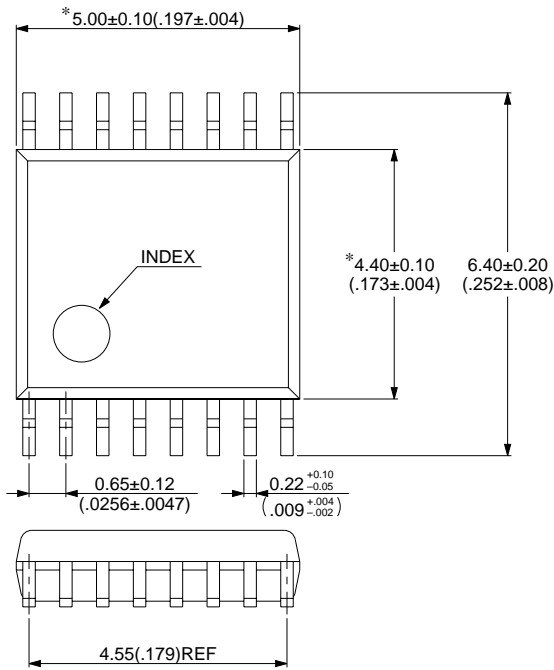

© 1994 FUJITSU LIMITED F16013S-2C-4

Dimensions in mm (inches).

(Continued)

FUJITSU LIMITED

For further information please contact:

Japan

FUJITSU LIMITED
Corporate Global Business Support Division
Electronic Devices
KAWASAKI PLANT, 4-1-1, Kamikodanaka
Nakahara-ku, Kawasaki-shi
Kanagawa 211-88, Japan
Tel: (044) 754-3763
Fax: (044) 754-3329

North and South America

FUJITSU MICROELECTRONICS, INC.
3545 North First Street
San Jose, CA 95134-1804, U.S.A.
Tel: 1-800-866-8608 Customer Response Center
Fax: 1-408-922-9179 Mon-Fri: 7am-5pm (PST)
Internet URL: <http://www.fujitsumicro.com>

Europe

FUJITSU MIKROELEKTRONIK GmbH
Am Siebenstein 6-10
63303 Dreieich-Buchsschlag
Germany
Tel: (06103) 690-0
Fax: (06103) 690-122

Asia Pacific

FUJITSU MICROELECTRONICS ASIA PTE. LIMITED
#05-08, 151 Lorong Chuan
New Tech Park
Singapore 556741
Tel: (65) 281-0770
Fax: (65) 281-0220

All Rights Reserved.

The contents of this document are subject to change without notice. Customers are advised to consult with FUJITSU sales representatives before ordering.

The information and circuit diagrams in this document presented as examples of semiconductor device applications, and are not intended to be incorporated in devices for actual use. Also, FUJITSU is unable to assume responsibility for infringement of any patent rights or other rights of third parties arising from the use of this information or circuit diagrams.

FUJITSU semiconductor devices are intended for use in standard applications (computers, office automation and other office equipment, industrial, communications, and measurement equipment, personal or household devices, etc.).

CAUTION:

Customers considering the use of our products in special applications where failure or abnormal operation may directly affect human lives or cause physical injury or property damage, or where extremely high levels of reliability are demanded (such as aerospace systems, atomic energy controls, sea floor repeaters, vehicle operating controls, medical devices for life support, etc.) are requested to consult with FUJITSU sales representatives before such use. The company will not be responsible for damages arising from such use without prior approval.

Any semiconductor devices have inherently a certain rate of failure. You must protect against injury, damage or loss from such failures by incorporating safety design measures into your facility and equipment such as redundancy, fire protection, and prevention of over-current levels and other abnormal operating conditions.

If any products described in this document represent goods or technologies subject to certain restrictions on export under the Foreign Exchange and Foreign Trade Control Law of Japan, the prior authorization by Japanese government should be required for export of those products from Japan.