

IDB-1394 Single Chip Controller

MB88388A, MB88389

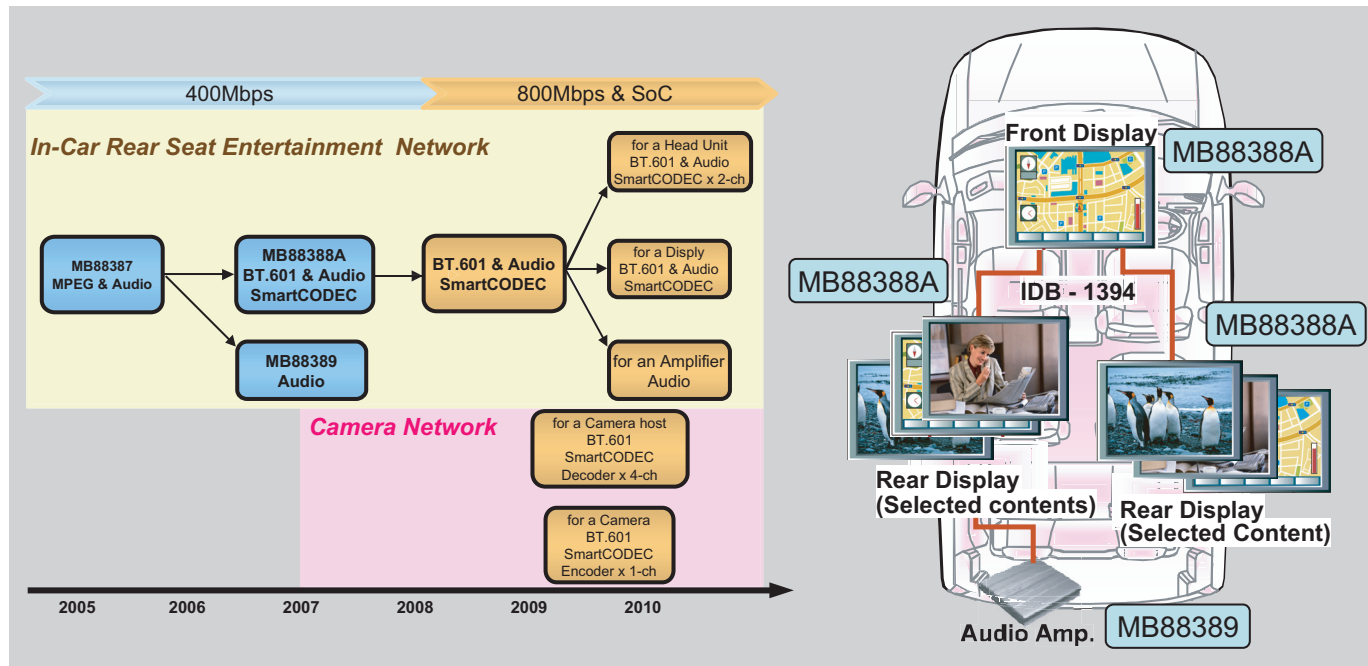

▶ Features

- S400 1394b PHY x 2 port with link layer
- BT.601 video I/F: BT656/digital RGB
- I²S audio I/F or IEC6058 (S/PDIF)
- 16-bit MPU/DMA I/F or SPI/I2C host I/F
- SmartCODEC: 1/3 compression engine
- DTCP cipher/decipher, AES accelerator
- IEC61383 AV protocol function
- Asynchronous and isochronous FIFOs
- 3.3V (I/O) and 1.8V (internal)
- LQFP-216 package (MB88388A), LQFP-100 package (MB88389)

▶ Applications

- In-car entertainment system
- Passenger display systems
- Vehicle camera data network for passive and active safety
- Vehicle camera for parking aid or reverse view

▶ Description

The MB88388A is the industry's first device to support vehicle navigation imaging using the IDB-1394 standard. The controller implements the Fujitsu proprietary SmartCODEC, a video codec specified under the IDB-1394 international standard for in-vehicle video transmission. SmartCODEC can compress and decompress high-resolution video without perceptible latencies in 2–3ms.

By combining the MB88388A with the MB88389 IC for IDB-1394 compliant audio, it is possible to realize a high-quality, cost effective, rear-seat entertainment system.

IDB-1394 Single Chip Controller

Block Diagrams

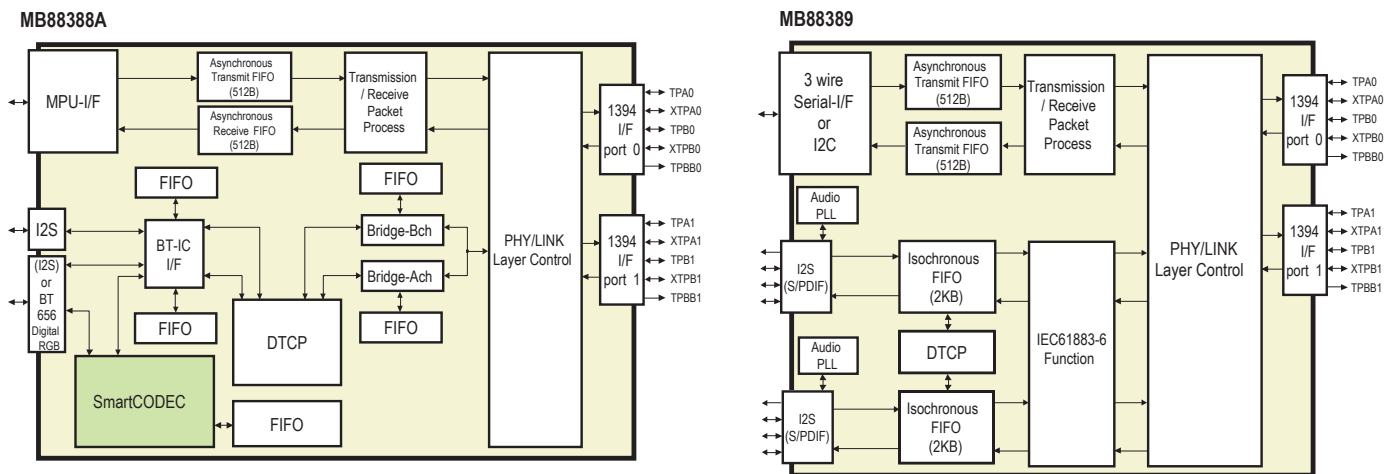

Specifications

Product	MB88388A	MB88389
Physical Layer	Complies with IEEE-1394b-2002 ⁽¹⁾ , max speed 400Mbps, 2 beta port	
Link Layer	Complies with IEEE-1394b-2002	
DTCP Functionality	Simultaneous encryption and decryption of two streams	
Transport Protocol Support	IEC61883-Part 8 (BT.601) ⁽²⁾ IEC61883-Part 6 (Audio) ⁽³⁾	IEC61883-Part 6 (Audio)
Video Interface	1 x BT656 or Digital RGB I/O (selectable)	None
Audio Interface	2 x I ² S ⁽⁴⁾ 8-channel I/O	2 x I ² S 8-channel or IEC60958 ⁽⁵⁾ I/O
SmartCODEC	Included	Not included
Operating Voltage	3.3V ± 0.3V (I/O), 1.8V ± 0.15V (internal)	
Operating Temperature	-40°C to 85°C	
Packaging	LQFP 216 pins, 0.4mm pitch, 24mm x 24mm	LQFP 100 pins, 0.5mm pitch, 14mm x 14mm

Notes:

1. IEEE-1394b-2002: An extension to the older IEEE1394a-2000 high-speed serial-bus standard used for PCs and audio-visual equipment. Expansions to this standard are currently underway, to enable faster transmission speeds and transmission across longer distances. This standard has been adopted for IDB-1394.
2. IEC61883-Part 8 (BT.601): IEC61883 is a transmission protocol established by the International Electrotechnical Commission, for digital interfaces of audio and visual equipments. BT.601 Transport Over IEEE-1394 is in the process of being ratified as Part 8.
3. IEC61883-Part 6 (Audio): A protocol for streaming audio over IDB-1394.
4. I²S: Stands for "Inter-IC Sound Bus." An interface standard for connecting digital audio equipment.
5. IEC60958: A standard established by the International Electrotechnical Commission for digitally transmitting audio signals.

FUJITSU MICROELECTRONICS AMERICA, INC.

Corporate Headquarters
 1250 E. Arques Avenue, M/S 333, Sunnyvale, CA 94085-5401
 Tel: (800) 866-8608 Fax: (408) 737-5999
 E-mail: inquiry@fma.fujitsu.com Web Site: <http://us.fujitsu.com/micro>

© 2007 Fujitsu Microelectronics America, Inc.
 All company and product names are trademarks or registered trademarks of their respective owners.
 Printed in the U.S.A. MCU-FS-21278-11/2007