

# **Introducing the Industry's Most Powerful 10Gigabit Ethernet Switching Solution**

**Ideal for High-density Backplane Switching Applications**

**Asif Hazarika**

**Fujitsu Microelectronics America, Inc.**

- 10GbE Switch Chip Recap – MB87Q3141
- Announcement
- 10GbE Market
- Next-generation Switch Chip – MB8AA3020
  - Key Features
  - Benefits
  - Enabling Technologies
- Architecture
- Applications
- Evaluation Results
- Competitive Analysis
- Availability
- Summary

# 10GbE Switch Chip Recap – MB87Q3141

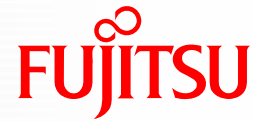

- 2003 introduction of 12-port, 10Gbps Ethernet switch chip
  - Industry's first (March 2003)
  - 12-port, 10GbE switch with on-chip CX4 PHYS
  - Benefits
    - High port density
      - Low latency
      - Compact size
      - Low power
  - Applications
    - Server blades, ATCA, Micro TCA and enterprise switches (1U pizza boxes, and modular switches)

- **Industry's Most Powerful, 20-port, 10Gigabit Ethernet (10GbE) Switching Solution**
  - High port density
  - 10GbE serial interface
  - Advanced QoS and congestion management
  - Built-in micro-engine
  - Low latency
  - Large buffer memory
  - Low power
  - Small footprint

- New market needs and emerging applications call for a bigger, better, denser, more-powerful chip
- Emerging applications like IPTV, VoD and video streaming to cell phones are demanding more network bandwidth
- 10GbE is fast emerging as the interface / backplane of choice in blade servers and ATCA/micro-TCA chassis
- Network equipment for Routers, Access and Wireless applications, carry 14 or more slots (ATCA and other proprietary chassis). These requires switches with 20 ports, running at non-blocking, full cross-sectional bandwidth; while supporting QoS / congestion management; and consuming little power

# Market is Ready for 10GbE

- Bandwidth! Bandwidth! Bandwidth!
  - Increasing bandwidth demands delivered at low cost per bit
- Market needs a standards-based technology to support backplanes and interconnects
  - Support standard building practices
  - Leverage economies of scale
  - Lower equipment cost
  - Widespread support
- Expecting a 10-fold increase in 10GbE shipment over the next 5 years

# Ethernet Switch Forecast

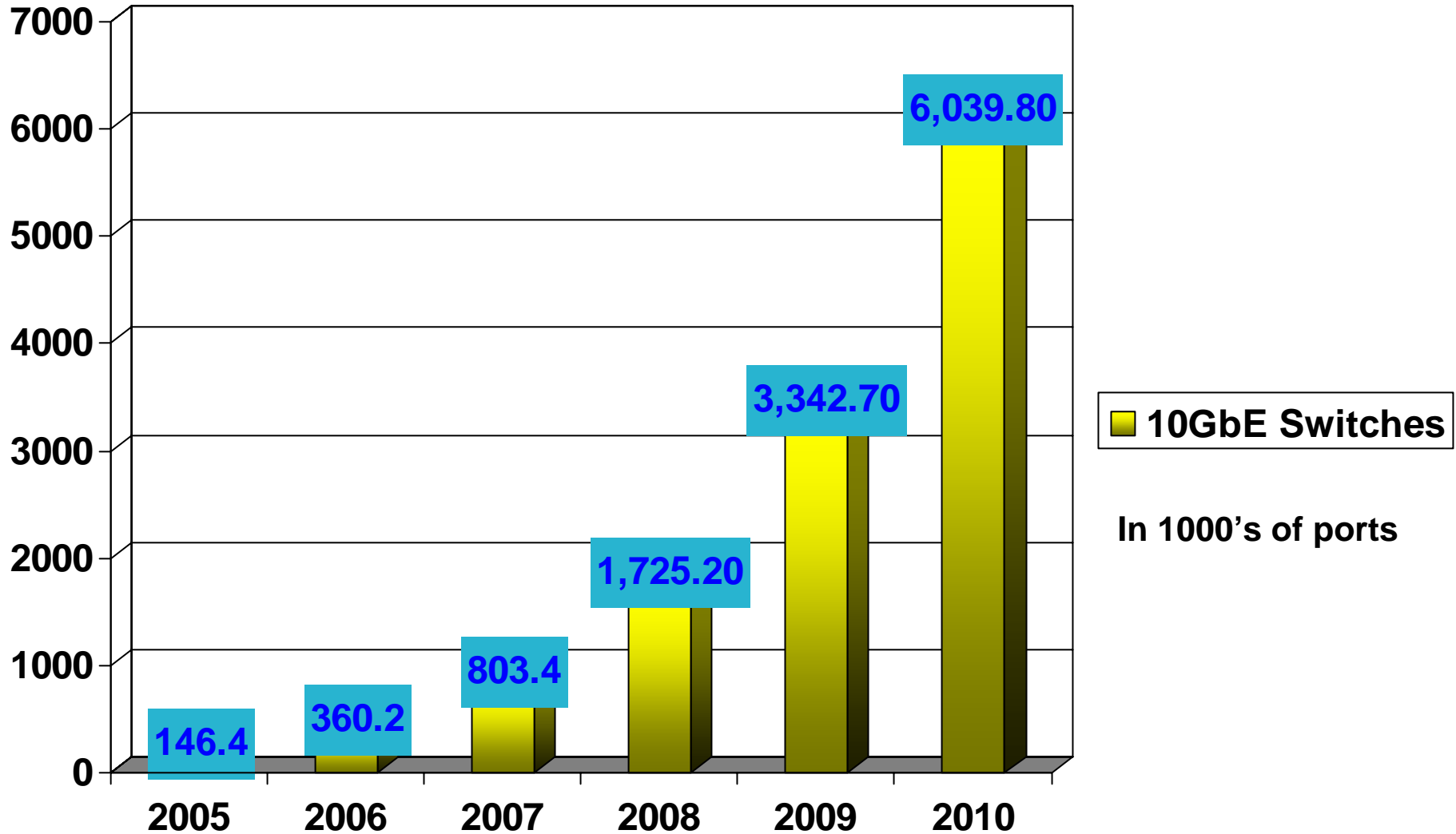

“Forecast: Ethernet Switches, Worldwide, 2003-2010”, July 2006, Source: Gartner Dataquest, 2006

# Next-Generation Switch Chip – MB8AA3020

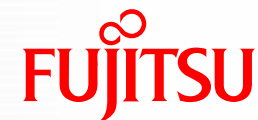

## ■ Industry Firsts

- 10GbE serial – direct XFP compatible interface
- Congestion management – BCN and priority pause
- On-chip micro-engine
  - Reduces S/W development time
- VLAN virtualization

## ■ Other Key Features

- Single-chip, 10GbE switch
- Number of 10GbE ports: 20
- Throughput: 400+Gbps
- MAC address: 16K
- Internal buffer: 2.9MB
- Management interface: two GbE/100/10 ports
- PHY interfaces
  - XAUI/CX4/KX4 (3.125Gbps x 4)

- Power and physical size
  - 15 to 20W
  - FCBGA1156 (35mm x 35mm)
- Technology
  - CMOS 90nm process

## ■ Benefits

- Fewer interconnects
- Reduced chip count and costs in having direct XFP interface
- Enhanced QoS
- Fast Firmware development
- Non-blocking wire-speed operation
- Low latency (300 ns)
- Board area savings
- Low power requirement

## ■ Enabling Technologies

- 10GbE serial
- 90nm process
- Multi-stream / multi-port memory

# The Fujitsu 20-port 10GbE Switch as a Managed Switch

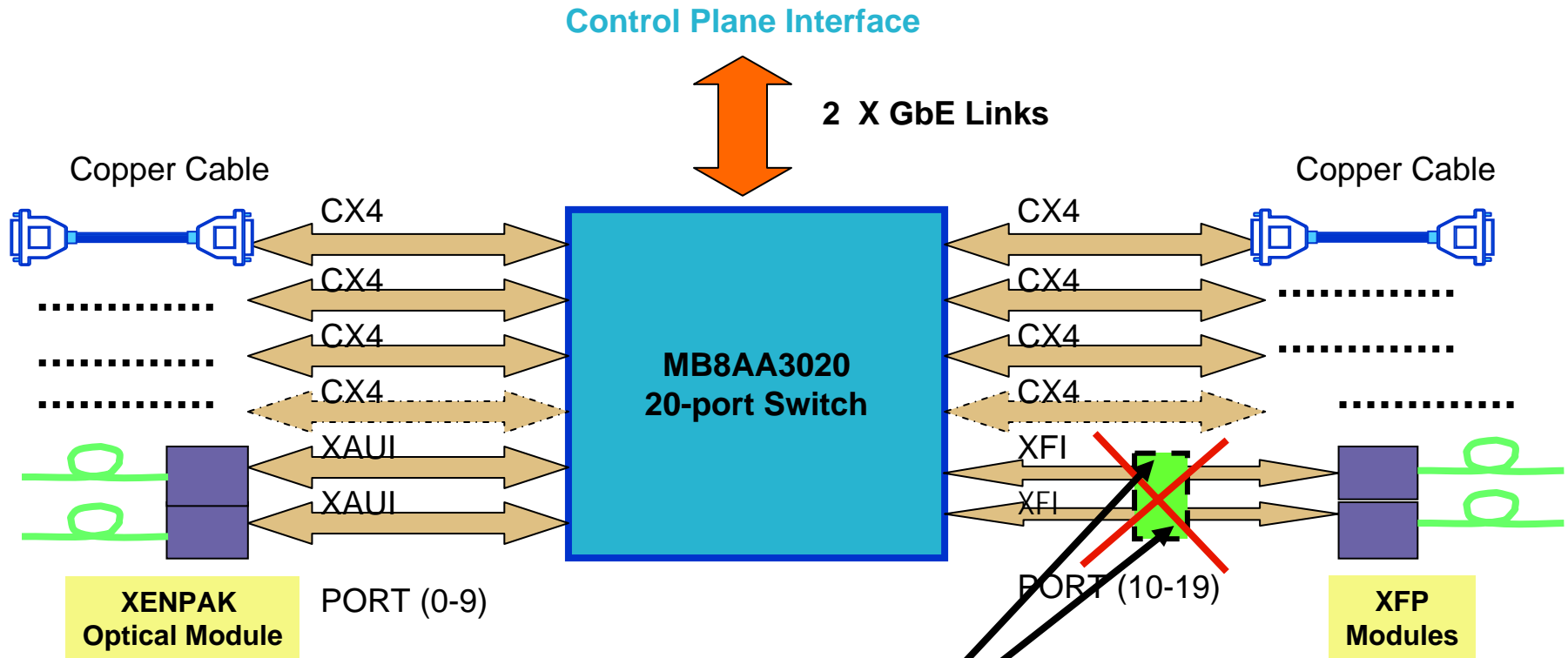
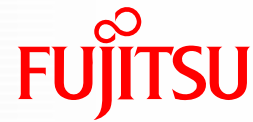

**Eliminates the need for XAUI to XFI conversion SerDes**  
Benefits:

- Eliminates cost of conversion – \$ 100 per chip X 20 ports
- Board area savings
- Less connections
- Reduced latency – otherwise introduced by conversion (130ns)
- Reduced power consumption

# Next-Generation Switch Chip – MB8AA3020 Architecture

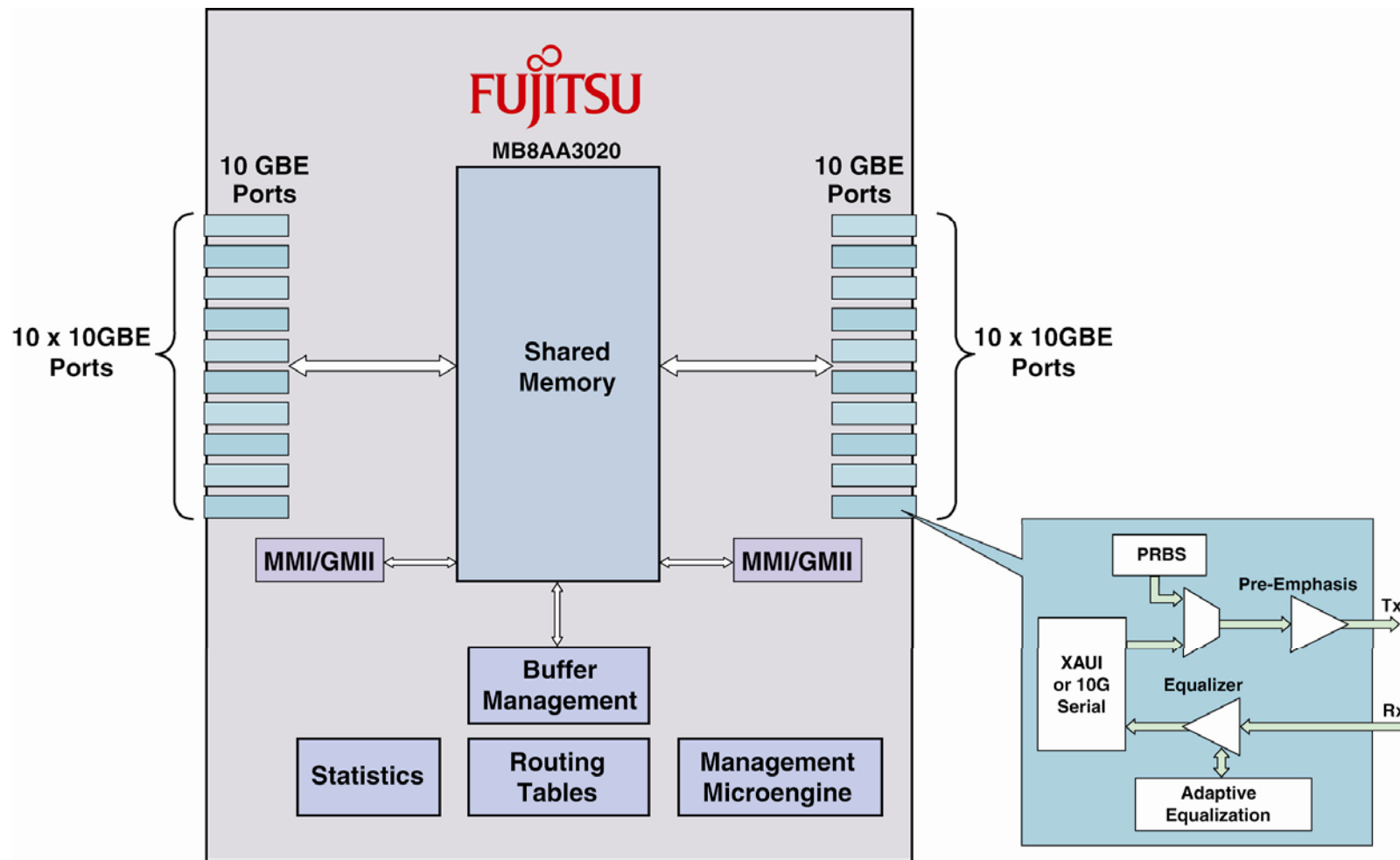
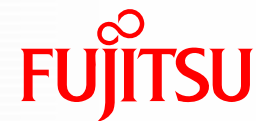

# Evaluation Board

- MB8AA3020 evaluation board
- Supported with:
  - Reference schematics
  - Layout
  - Reference software

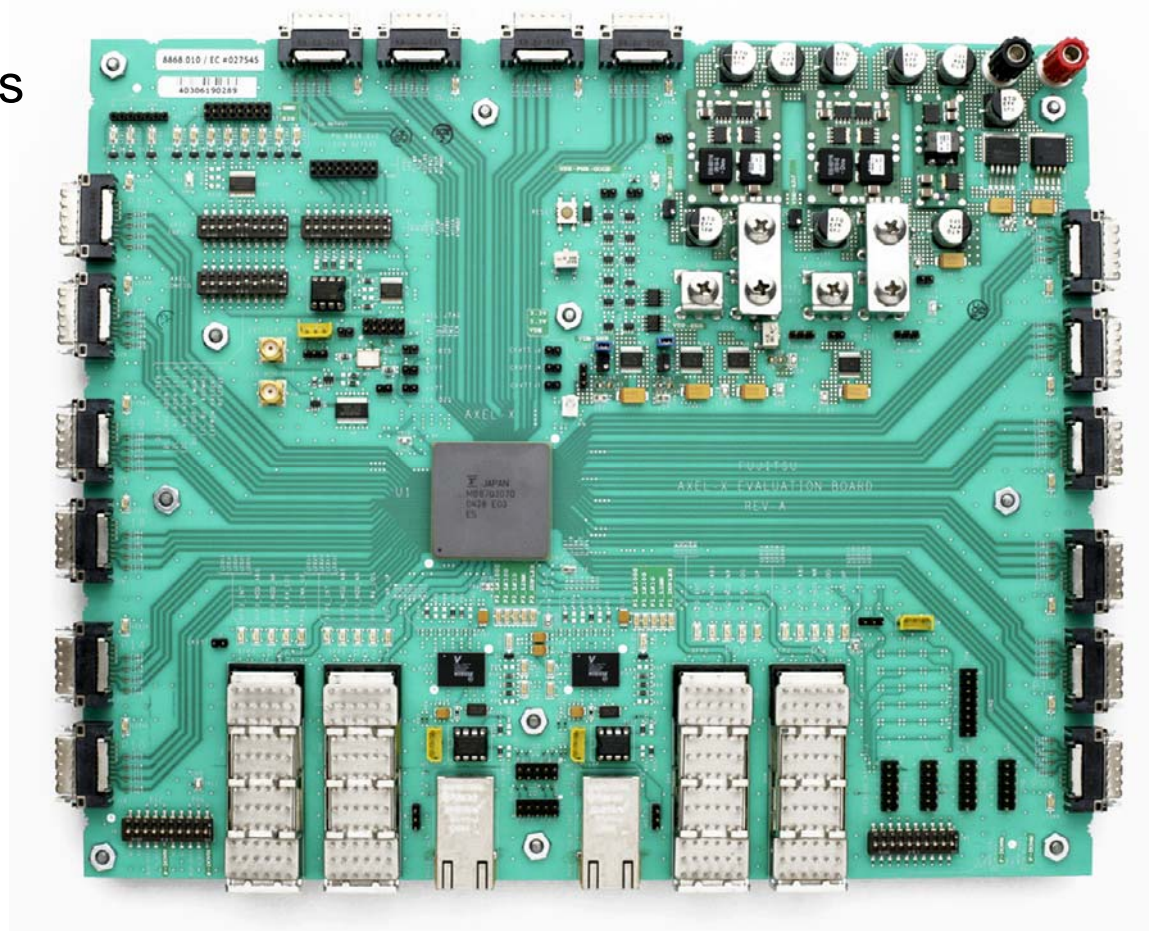

- Blade-server switching blade
- ATCA carrier node blade
  - Mesh configuration
  - Centralized switch
- Micro-TCA hub
- Enterprise switching
- High-performance computing

# Next-Generation Switch Chip – MB8AA3020 Applications

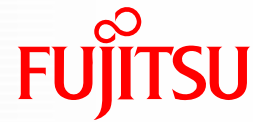

## ATCA/AMC Application

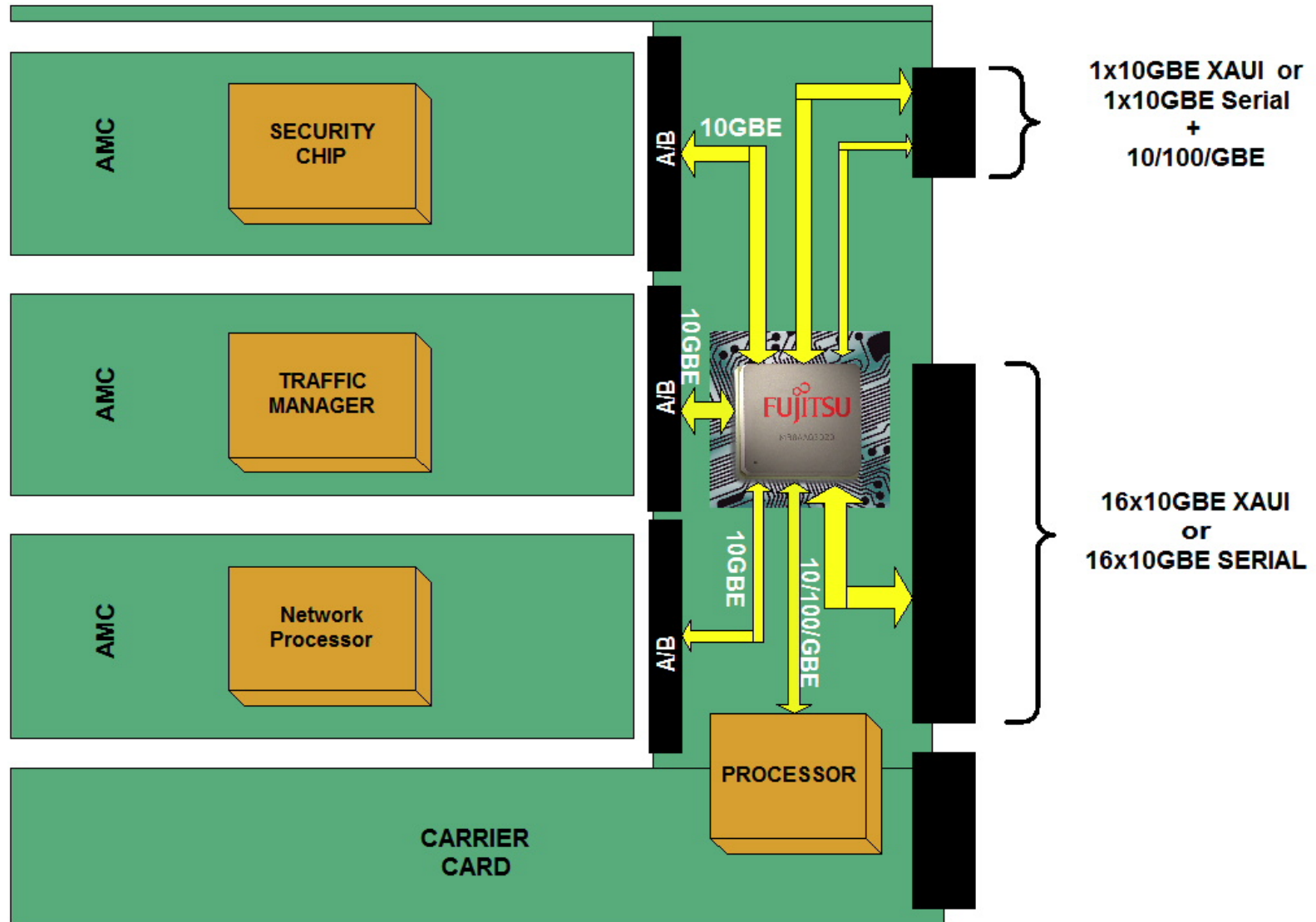

- Comparison of the MB8AA3020 against the competition, any available test results
  - Only product with 10GbE serial capability
  - On-chip micro-engine speeds up embedded S/W development and reduces time-to-market
  - Advanced QoS and congestion-management features
  - Larger buffer memory
  - Lower power
  - Smallest footprint for this class of device

- Product availability
  - Samples
    - Available now (August 2006)
  - Mass production
    - Q4 2006
  
- Support tools
  - Reference board / systems
    - Available now
  - Development tools
    - October 2006

- Firsts in 10Gbps Ethernet switching technology
  - Congestion management derived from pre-standard IEEE work
  - On-chip, XFP-compatible, 10GbE serial interface
  - On-chip micro-engine to support 10/100/1G control plane interface
- Value proposition
  - Lower the total system cost of the high-performance IT infrastructure and network elements
  - Build reliable, faster and larger layer-2 switches at lower cost and power that state-of-the-art LAN services with a very high quality of service

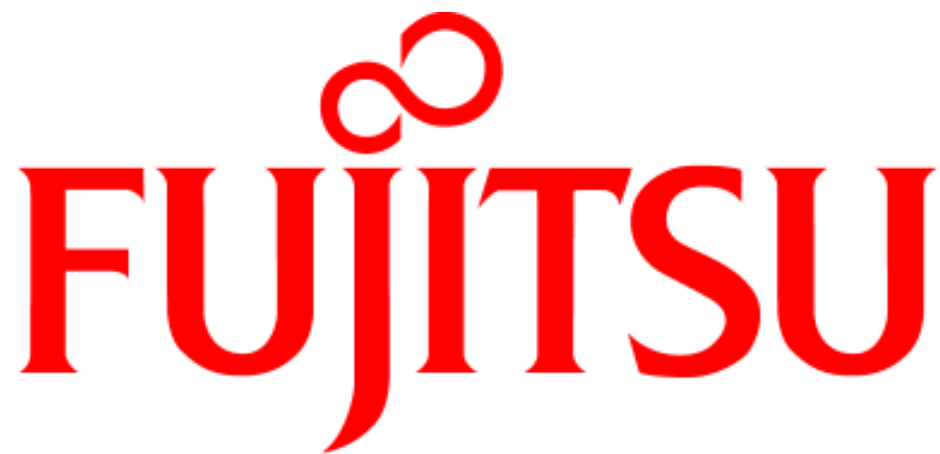

FUJITSU

**THE POSSIBILITIES ARE INFINITE**