

# 12-Port 10Gbps Ethernet Switch Chip - MB87Q3070

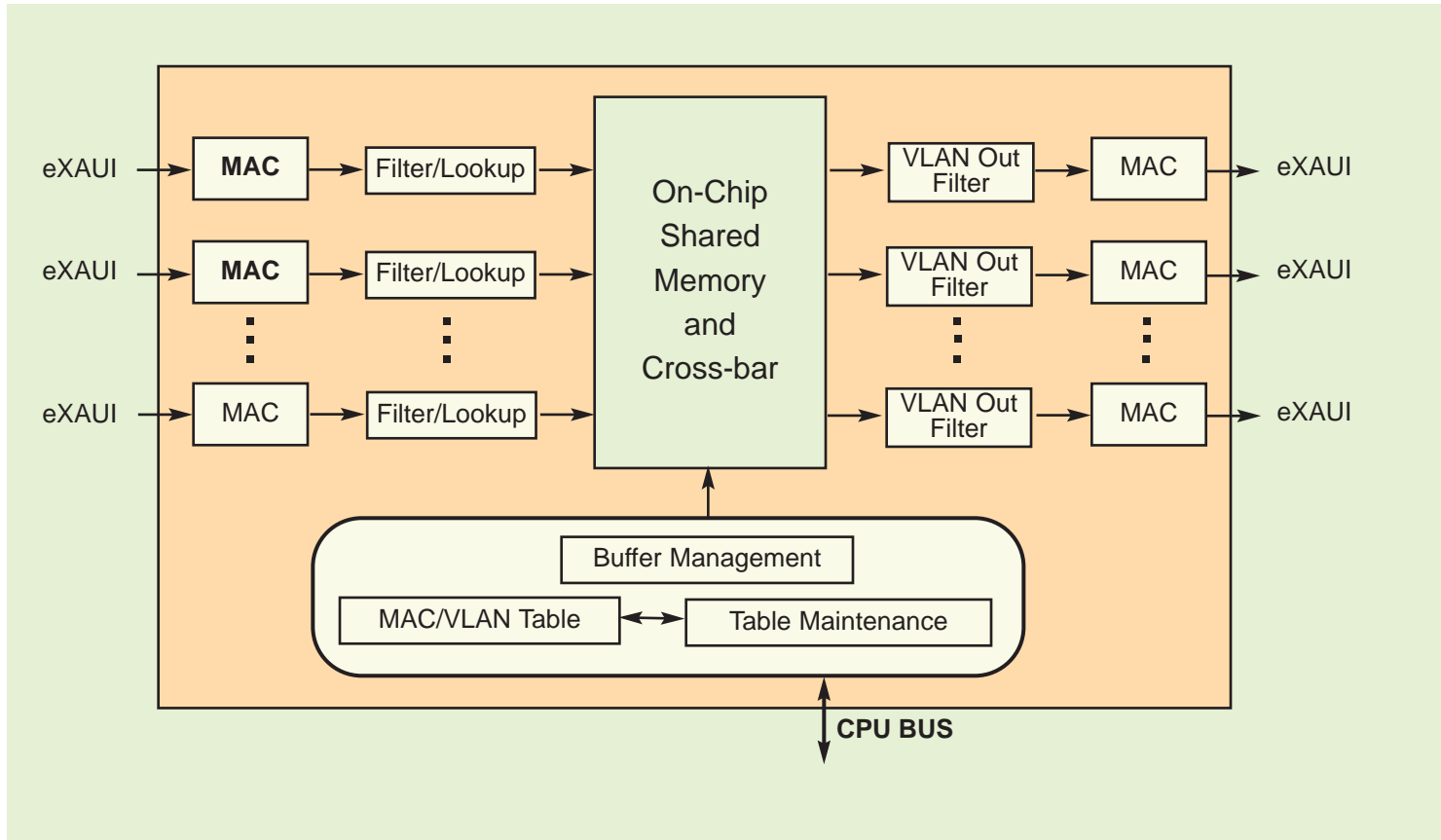

## ► Features

- 12-port 10Gbps switching operation at wire speed
- 240Gbps aggregate throughput
- Integrated SERDES with XAUI and eXAUI capability
- On-chip shared memory for high throughput switching
- Cut-through routing for low latency transfer
- Jumbo frame support
- Deficit Round Robin for fair bandwidth sharing
- L2 unicast forwarding, address learning and aging
- L2 multicast forwarding using GMRP
- L2 lookup table with 8K MAC address
- 802.1Q port-based VLAN
- VLAN table with 4K VLAN address
- User-programmable VLAN Tag Protocol Type
- 802.1Q Multiple Spanning Tree
- 802.3ae full-duplex operation using PAUSE flow control
- Multiple chip configuration for cluster applications
- RMON and SMON statistics counters
- Processor interface for housekeeping
- 1.2V and 2.5V supply, 0.11µm CMOS process

# 12-Port 10Gbps Ethernet Switch Chip

## ▶ Benefits

- High integration of complete switch-on-a-chip enables the design of high port density systems at low per-port cost
- Enhanced XAUI for longer cable connection enables low-cost connection and flexible design option
- High throughput, low latency, jumbo frame support, and multi-chip configuration enables high performance scalable cluster system
- Reduces complexity and cost of CPU subsystems
- Supports wide applications of voice, video, and data traffic over Ethernet networks
- Enables easy network maintenance and effective network management
- Simplifies system design and provides flexibility

## ▶ Description

Fujitsu's 10Gbps Ethernet switch chip with CX4 interface is the industry's first switch solution to address the need for 10Gbps Ethernet over copper. This switch chip can be connected with a variety of devices to create a myriad of applications in the overall switch market. This device can be used in 10Gbps Ethernet switches for scalable switching, Blade Server Backplanes, Server Switches, and 1Gbps/10Gbps switch for large 1Gbps Ethernet modular switch. This device can be used in conjunction with 10Gbps XENPAK optical modules and NIC cards with TCP/IP offload engines in server and file system.

This switch can be used in a variety of applications:

- Ethernet switch for Enterprise, MAN and WAN
- Aggregation switch for 1Gbps/100Mbps/10Mbps Ethernet switches
- Back-plane switch for communication systems
- Switch for storage area network
- Switch for cluster interconnect
- High performance cluster



## FUJITSU MICROELECTRONICS AMERICA, INC.

Corporate Headquarters

1250 E. Arques Ave. Sunnyvale, CA 94088-3470

Tel: (800) 866-8608 Fax: (408) 737-5999

E-mail: [inquiry@fma.fujitsu.com](mailto:inquiry@fma.fujitsu.com) Web Site: <http://www.fma.fujitsu.com>

©2004 Fujitsu Microelectronics America, Inc.

All company and product names are trademarks or registered trademarks of their respective owners.

Printed in the U.S.A. 10GEASSP-FS-21033-3/2004