

TOUCH PANEL CONTROL BOARD 7-WIRE USB

N16B-0558-B740 USB Interface Controller Board Quick Reference 7-Wire Resistive Touch Panels

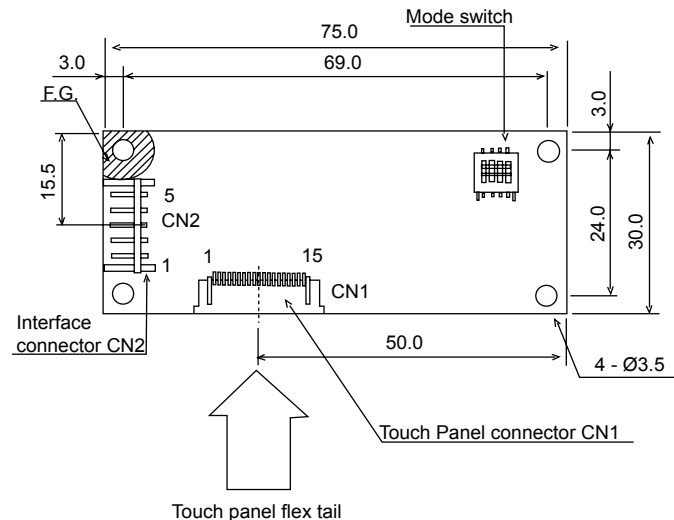

■ FEATURES

- High quality and reliability touch panel control board with switch selectable cable tail exit direction.
- USB 1.1 Interface for direct connection to PC or alternative USB interfaces.
- Board is USB bus powered.
- Used to control 7-wire resistive touch panels.
- RoHS compliant

■ SWITCH SETTINGS

SW1	ON		OFF		ON		OFF	
SW2	ON		ON		OFF		OFF	
SW3	ON		ON		OFF		ON	

[SW4 is not used]

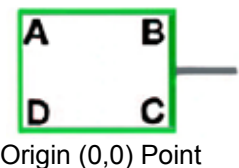

■ CONSTRUCTION

Specification Item		N16B-0558-B740 7-Wire USB Control Board
Mechanical	Size / Weight	75mm x 30mm / 30g
Electrical	Supply voltage(max./min.)	Vcc 5.5V/4.1 V
	Operating current (detect)	36 mA at Vcc = 5V and T = 25 degrees
	Sleep Mode current	6 mA at Vcc = 5V and T = 25 degree s
Environment	Operating Temperature	-5° C to +60° C
	Storage Temperature	-30° C to +70° C
	Humidity	20%RH to 85% RH at +38° C maximum wet bulb temperature

USB 7-Wire Control Board

■ **TOUCH PANEL CONNECTION CN1 (FCI: SFW15R-1STAE1-LF)**

■ **INTERFACE CONNECTION CN2 (JST #: S5B EH (LF))**

1.	+5V (Vcc)	3.	D-(Signal)	5.	Frame Ground
2.	D+ (Signal)	4.	Ground		

Complete specification document is available on request for customers with whom we have an approved NDA in place.

Fujitsu Components International Headquarter Offices

Japan

Fujitsu Component Limited
Gotanda-Chuo Building
3-5, Higashigotanda 2-chome, Shinagawa-ku
Tokyo 141, Japan
Tel: (81-3) 5449-7010
Fax: (81-3) 5449-2626
Email: promothq@ft.ed.fujitsu.com
Web: www.fcl.fujitsu.com

North and South America

Fujitsu Components America, Inc.
250 E. Caribbean Drive
Sunnyvale, CA 94089 U.S.A.
Tel: (1-408) 745-4900
Fax: (1-408) 745-4970
Email: components@us.fujitsu.com
Web: <http://us.fujitsu.com/components/>

Europe

Fujitsu Components Europe B.V.
Diamantlaan 25
2132 WV Hoofddorp
Netherlands
Tel: (31-23) 5560910
Fax: (31-23) 5560950
Email: info@fceu.fujitsu.com
Web: emea.fujitsu.com/components/

Asia Pacific

Fujitsu Components Asia Ltd.
102E Pasir Panjang Road
#01-01 Citilink Warehouse Complex
Singapore 118529
Tel: (65) 6375-8560
Fax: (65) 6273-3021
Email: fcal@fcal.fujitsu.com
Web: <http://www.fujitsu.com/sg/services/micro/components/>

©2007 Fujitsu Components America, Inc. All rights reserved. All trademarks or registered trademarks are the property of their respective owners.

Fujitsu Components America or its affiliates do not warrant that the content of datasheet is error free. In a continuing effort to improve our products Fujitsu Components America, Inc. or its affiliates reserve the right to change specifications/datasheets without prior notice.
Rev. June 4, 2007.