

STANDARD Micro Controller Specification

N010-0559-V041 PS/2 Interface Controller Chip

(Summary Sheet)

FID-550 7- Wire Series

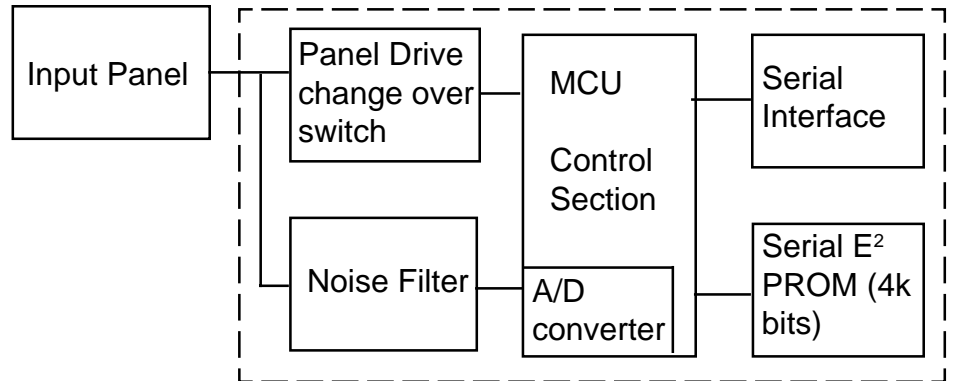

■ FEATURES

- High quality and reliability touch panel micro
- PS/2 Interface
- Supplied in boxes of 1600 pieces
- Used to control the FID-550 7-Wire series touch panel

■ CONSTRUCTION

- 64 pin PQFP MCU with masked ROM

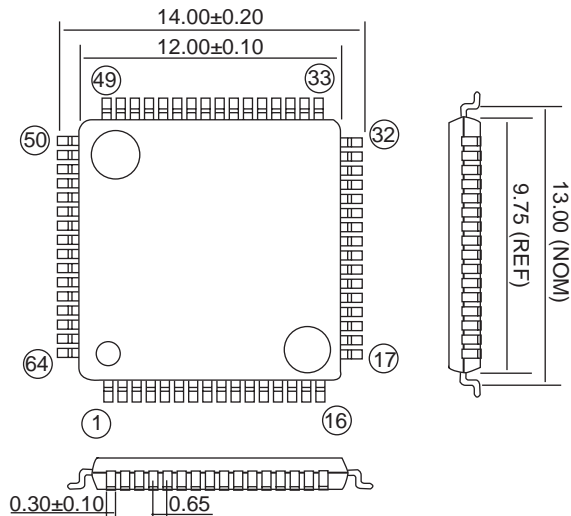

1	Unused	17	Unused	33	Unused	49	Vss
2	S/P*	18	Unused	34	Unused	50	EROMCS
3	PMSR	19	*RST	35	Unused	51	Unused
4	EMSR1	20	MOD0	36	Unused	52	EROMS1
5	EMSR2	21	MOD1	37	Unused	53	EROMS0
6	EMSR3	22	X0	38	Unused	54	EROMCK
7	EMSR4	23	X1	39	Unused	55	RXD
8	Unused	24	Vss	40	Unused	56	Vcc
9	Unused	25	Unused	41	Unused	57	TXD
10	Unused	26	Unused	42	*PSW0	58	UCK1
11	Avcc	27	Unused	43	Unused	59	UCK0
12	AVR	28	Unused	44	Unused	60	Unused
13	Avss	29	PSW4	45	Unused	61	Unused
14	CSEL	30	*PSW3	46	Unused	62	Unused
15	*PINT	31	PSW2	47	Unused	63	OS1
16	*RXINT	32	*PSW1	48	Unused	64	OS0

PS/2 Interface Controller Chip

■ PART NUMBER OF COMPLETE CHIP SPECIFICATION

Part Number	Number of Pages	Full Technical Documentation Reference
N010-0559-V041	34	Tech Bes N-28745

Fujitsu Components International Headquarter Offices

Japan

Fujitsu Component Limited
Gotanda-Chuo Building
3-5, Higashigotanda 2-chome, Shinagawa-ku
Tokyo 141, Japan
Tel: (81-3) 5449-7010
Fax: (81-3) 5449-2626
Email: promothq@ft.ed.fujitsu.com
Web: www.fcl.fujitsu.com

North and South America

Fujitsu Components America, Inc.
250 E. Caribbean Drive
Sunnyvale, CA 94089 U.S.A.
Tel: (1-408) 745-4900
Fax: (1-408) 745-4970
Email: marcom@fcai.fujitsu.com
Web: www.fcai.fujitsu.com

Europe

Fujitsu Components Europe B.V.
Diamantlaan 25
2132 WV Hoofddorp
Netherlands
Tel: (31-23) 5560910
Fax: (31-23) 5560950
Email: info@fceu.fujitsu.com
Web: www.fceu.fujitsu.com

Asia Pacific

Fujitsu Components Asia Ltd.
102E Pasir Panjang Road
#04-01 Citilink Warehouse Complex
Singapore 118529
Tel: (65) 375-8560
Fax: (65) 273-3021
Email: fcal@fcal.fujitsu.com
www.fcal.fujitsu.com

© 2002 Fujitsu Components America, Inc. All company and product names are trademarks or registered trademarks of their respective owners. Rev. 03/2002