

BATTERY DRIVEN, FTP-608 Series 2" HIGH SPEED THERMAL PRINTER

FTP-628MCL353/354 #01 / #02

■ OVERVIEW

The FTP-628 MCL Series are battery driven high-speed printers with a 2-inch paper width equivalent.

The FTP-628 MCL Series can be used for a variety of applications, such as portable terminals, POS, ticket issuing machines, label printers, banking terminals, and measurement and medical equipment.

■ HIGHLIGHTS

- **Ultra compact**
Height 26.4 mm, width 83.5 mm, depth 43.0 mm
- **High speed printing**
It can print at 80 mm/s (640 dotlines/s) maximum by using Fujitsu's unique head drive control.
- **Auto Cutter**
Full cut type (#01) and partial cut type (#02) printers are available.
- **Auto paper loading**
Our unique platen release mechanism allows a wide paper route even if the printer is ultra-compact, so paper can be easily inserted. Conventional auto loading is also available.
- **RoHS compliant**



FTP-628MCL354

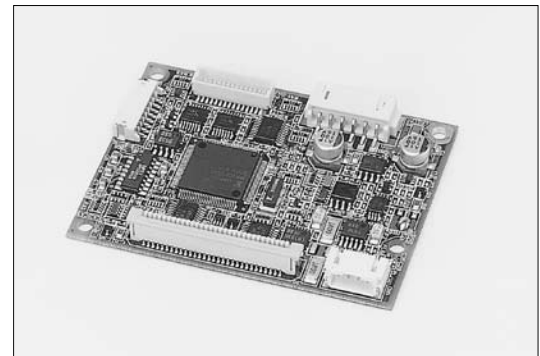

FTP-628DSL306

■ PART NUMBERS

		Part Number
Printer mechanism with Cutter		FTP-628MCL353#01 (front paper insertion, full cut type with knob) FTP-628MCL353#02 (front paper insertion, partial cut type with knob) FTP-628MCL354#01 (bottom paper insertion, full cut type without knob) FTP-628MCL354#02 (bottom paper insertion, partial cut type without knob)
LSI for driving		FTP-628CU301R (ANK only) FTP-628CU601R
Interface Board for Mech/Cutter	Cutter supported	FTP-628DCL301R Parallel (Centronics) FTP-628DSL306R Serial (RS232C) FTP-628DSL608R (USB)
Interface cables	Parallel (Centronics)	FTP-628Y202
	Serial (RS232C)	FTP-628Y302
	USB	FTP-629Y301
Power cable	Head, motor, logic	FTP-628Y402

■ SPECIFICATIONS

Item	Specifications
Part number	FTP-628MCL353#01/#02, FTP-628MCL354#01/#02
Printing method	Thermal-line dot method
Dot structure	384 dots/line
Dot pitch (Horizontal)	0.125 mm (8 dots/mm)—Dot density
Dot pitch (Vertical)	0.125 mm (8 dots/mm)—Line feed pitch
Effective printing area	48 mm
Number of columns	ANK 32 columns/line (maximum 12 x 24 dot font)
Paper width	58 mm
Paper thickness	60 to 100 μ m (some paper in this range may not be used because of paper characteristics)
Printing Speed	Maximum 80mm/sec. (640 dot line/sec.) at 8.5V
Character types	Alphanumeric, kana: 159 types International characters: 195 types JIS Kanji (Kanji CG loaded board): about 6800 types
Character, dimensions (W×H), number of columns	12 × 24 dots, (1.5 × 3.0 mm), 32 columns: ANK 24 × 24 dots, (3.0 × 3.0 mm), 16 columns: ANK 8 × 16 dots, (1.0 × 2.0 mm), 48 columns: ANK 16 × 16 dots, (2.0 × 2.0 mm), 24 columns: ANK

■ SPECIFICATIONS

Item		Specification
Interface		Conforms to RS232C / Centronics
Power supply	For print head	4.2 - 8.5 VDC average current, 0.78A (0.93A) peak value (print ratio: 12.5%, print speed: 50mm/sec. at 7.2V)
	For motor	4.2 - 8.5 VDC, 1A maximum
	For cutter	5 VDC \pm 5%, 1A maximum
	For logic	3.0 to 5.25 VDC \pm 5%, 0.1 A maximum
Dimensions	Mechanism with cutter	MCL353 83.5 x 43.0 x 26.4 mm (WxDxH) MCL354 80.5 x 43.0 x 26.4 mm (WxDxH)
	Interface board	69.3 x 52 x 15mm
Weight	Mechanism with cutter	Approximately 120g
	Interface board	Approximately 20g
Life	Head	Pulse resistance: 100 million pulses/dot (under our standard conditions); Abrasion resistance: paper traveling distance 50km (print ratio: 25% or less)
	Cutter	300,000 cuts
Operating environment	Operating temperature*	0° C to 50° C
	Operating humidity	20 to 85% RH (no condensation)
	Storage temperature	-20° C to +60° C (paper not included)
	Storage humidity	5 to 90% RH (no condensation)
Detection function	Head temperature detection	Detected by thermistor
	Paper out/mark detection	Detected by photo-interrupter
	Platen release	Detected by sliding switch
Recommended thermal sensitive paper		High Sensitive Paper TF50KS-E4 (Nippon Paper)
		Standard paper: TF60KS-E(Nippon Paper), FTP-020PU001 (58mm), PD105R (Oji Paper), FTP-020P0701 (58mm)
		Medium Life Paper TF60KS-F1, FTP-020P0102 (58mm), PD170R (Oji Paper), P220VBB-1 Mitsubishi Paper)
		Long Life Paper PD160R-N (Oji Paper), AFB-235 (Mitsubishi Paper), TP50KJ-R (Nippon Paper), HA220AA (Nippon Paper)

*+5°C to +40°C printing density assurance range (-25 to 70°C capability)

■ FUNCTION OF INTERFACE BOARD

Item	Item	Item	Item
1. Test print function	8. Cutter trouble detect		
2. Paper out detection	9. Motor power saving function		
3. Paper near end detection	10. Mark detection function		
4. Platen open detection	11. MCU operation abnormality detection		
5. Thermal head temperature abnormality detection	12. Power ON/OFF sequence protection		
6. Blow-out fuse detection	13. Motor over-current protection		
7. Head voltage abnormality detection	14. Hardware timer		

■ DIMENSIONS

1. Printer mechanism

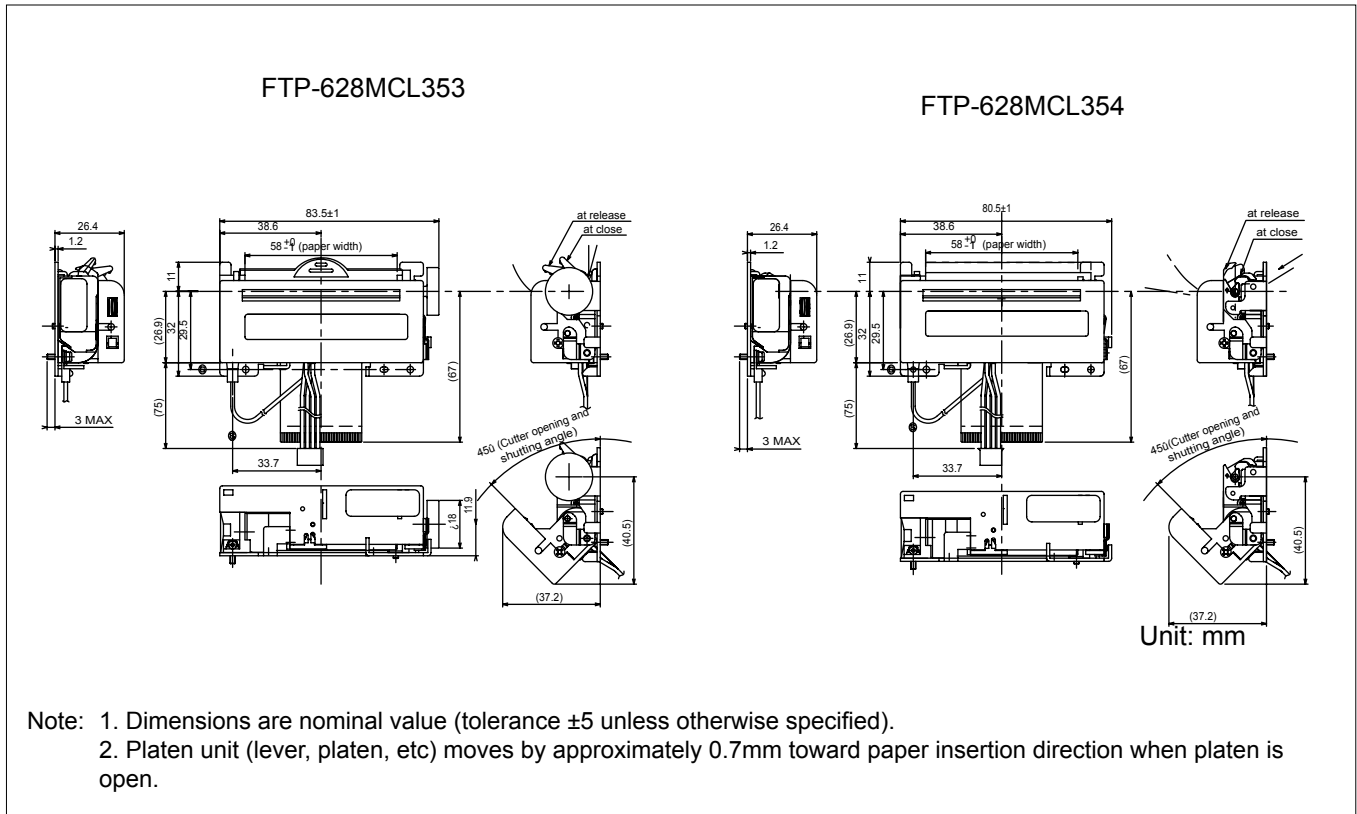

1. Connector (FPC) specification (CN4)

(1) Connector

Mechanical unit side: FPC connector

Remote side (housing site): 52610-3071 (made by Molex)

(2) Pin assignment on the mechanical side

No	Signal	I/O	Contents
1	PHK	—	Cathode for photo interruptor
2	VSEN	I	paper sensor power
3	PHE	O	Emitter for photo interruptor
4	SW1	O	Platen release switch
5	SW2	I	Platen release switch
6	VH	I	Head drive power
7	VH	I	
8	DI	I	Data in
9	CLK	I	Synchronous clock for communication
10	GND	—	Ground power supply for thermal head
11	GND	—	
12	STB6	I	Thermal head energizing control signal
13	STB5	I	
14	STB4	I	
15	VDD	I	Logic power
16	TM	O	Thermally sensitive resistor input terminal 1
17	TM	O	Thermally sensitive resistor input terminal 2
18	STB3	I	Thermal head energizing control signal
19	STB2	I	
20	STB1	I	
21	GND	—	Ground power supply for thermal head
22	GND	—	
23	$\overline{\text{LAT}}$	I	Data latch
24	DO	O	Data out
25	VH	I	Power supply for thermal head
26	VH	I	
27	MT A	I	Stepping motor excitation signal
28	$\overline{\text{MT A}}$	I	
29	MT B	I	
30	$\overline{\text{MT B}}$	I	

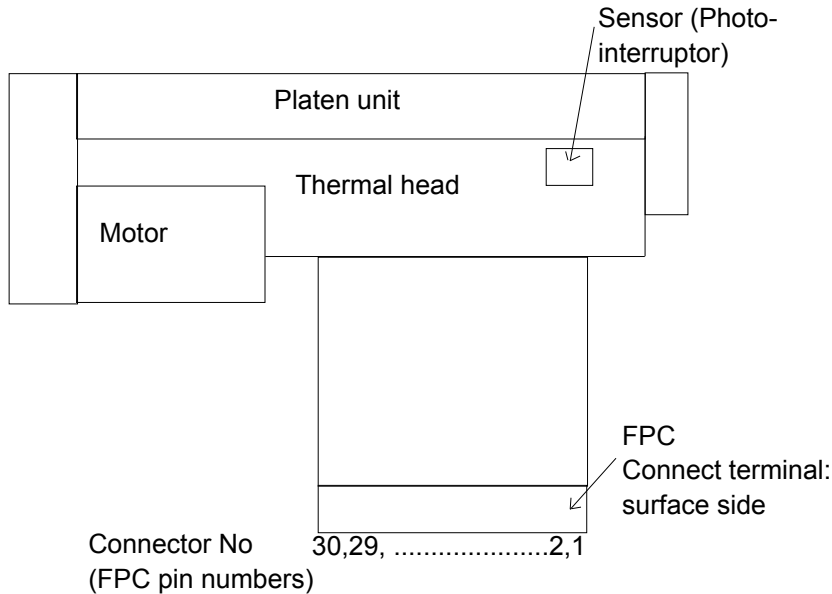

2. Cutter (CN5)

Connector on control circuit side: B4B-PH-K-S (J.S.T. or equivalent)

No.	Signal	I/O	Contents	No.	Signal	I/O	Contents
1	SW1	O	Cutter position detect signal	2	SW2	O	Logic ground
3	MT+		Stepping motor coil excitation A	4	MT-		Not connected

Fujitsu Components International Headquarter Offices

Japan

Fujitsu Component Limited
Gotanda-Chuo Building
3-5, Higashigotanda 2-chome, Shinagawa-ku
Tokyo 141 8630, Japan
Tel: (81-3) 5449-7010
Fax: (81-3) 5449-2626
Email: promothq@fcl.fujitsu.com
Web: www.fcl.fujitsu.com

North and South America

Fujitsu Components America, Inc.
250 E. Caribbean Drive
Sunnyvale, CA 94089 U.S.A.
Tel: (1-408) 745-4900
Fax: (1-408) 745-4970
Email: components@us.fujitsu.com
Web: <http://us.fujitsu.com/components/>

Europe

Fujitsu Components Europe B.V.
Diamantlaan 25
2132 WV Hoofddorp
Netherlands
Tel: (31-23) 5560910
Fax: (31-23) 5560950
Email: info@fceu.fujitsu.com
Web: emea.fujitsu.com/components/

Asia Pacific

Fujitsu Components Asia Ltd.
102E Pasir Panjang Road
#01-01 Citilink Warehouse Complex
Singapore 118529
Tel: (65) 6375-8560
Fax: (65) 6273-3021
Email: fcal@fcal.fujitsu.com
Web: <http://www.fujitsu.com/sg/services/micro/components/>

©2009 Fujitsu Components America, Inc. All rights reserved. All trademarks or registered trademarks are the property of their respective owners.

Fujitsu Components America or its affiliates do not warrant that the content of datasheet is error free. In a continuing effort to improve our products Fujitsu Components America, Inc. or its affiliates reserve the right to change specifications/datasheets without prior notice.
Rev. February 26, 2009.