

24V DRIVEN, RECEIPT PRINTER MINI UNIT

2" HIGH SPEED THERMAL PRINTER UNIT

FTP-627USL431/631

■ OVERVIEW

The FTP-627 USL Series are 24V driven high-speed printers with a ultra low profile auto cutter and long life. The FTP-627 USL Series can be used for a variety of applications, such as POS terminals, mini Kiosks, banking terminals, and measurement and medical equipment.

■ FEATURES

- **Ultra low profile**
Height 145 mm, width 105 mm, depth 120 mm
- **Windows®2000/XP, Linux, and OPOS drivers**
- **High speed printing**
It can print at 100 mm/s (or 150 mm/s) maximum by using Fujitsu's unique head drive control.
- **Auto Cutter**
Long life and high reliable guillotine with dedicated motor.
- **Easy paper loading**
Our lever platen release mechanism allows a wide paper route, so 83mm diameter paper can be easily inserted.
- **Multifunctional die-cast frame**
Wide operating temperature range, long continuous printing, high ESD absorption and discharge of static electricity vibration and shock resistant.
- **Barcodes**
Prints standard, extended and 2-D types
- **RoHS compliant**



FTP-627USL431/631

■ PART NUMBERS

		Part Number	Power	Spool
Printer mechanism /cutter and board		FTP-627USL431/631 (USB Interface)	5V / 24V	Y
		FTP-627USL435/635 (Serial Interface)	5V / 24V	Y
		FTP-627USL440/640 (USB /Serial)	24V only	N
			Length	
Operation panel cable		FTP-627Y203	300mm	
Interface cables	Serial (RS-232C)	FTP-628Y302	500mm	
	USB (V1.1)	FTP-629Y301	1,000mm	
Power cables	Logic	FTP-629Y401	300mm	
	Head, Motor	FTP-629Y601	300mm	

* Interface board is the FTP-627DSL601R (Serial /USB)
 FTP-627DSL603/613-R (USB)
 FTP-627DSL605/615-R (Serial)

■ SPECIFICATIONS

Item		Specifications	
Part number		FTP-627USL431/435	FTP-627USL631/635
Printing method		Thermal-line dot method	
Dot structure		432 dots/line	
Dot pitch (Horizontal)		0.125 mm (8 dots/mm)—Dot density	
Dot pitch (Vertical)		0.125 mm (8 dots/mm)—Line feed pitch	
Effective printing area		54 mm	
Number of columns		ANK 36 columns/line (maximum 12 x 24 dot font)	
Paper width		58 mm	
Paper diameter		83 mm	
Paper thickness		60 to 100 μ m (some paper in this range may not be used because of paper characteristics)	
Printing Speed	USL4xx	Maximum 100mm/sec. (800 dot line/sec.) at 24V, 25°C	
	USL6xx	Maximum 150mm/sec. (1200 dot line/sec.) at 24V, 25°C	
Character types		Alphanumeric, kana:	159 types
		International characters:	195 types
		JIS Kanji (Kanji CG loaded board):	about 6800 types
Character, dimensions (W×H), number of columns		12 × 24 dots, (1.5 × 3.0 mm), 36 columns: ANK 24 × 24 dots, (3.0 × 3.0 mm), 18 columns: ANK 8 × 16 dots, (1.0 × 2.0 mm), 54 columns: ANK 16 × 16 dots, (2.0 × 2.0 mm), 27 columns: ANK	
Barcodes	Standard	UPC-A, UPC-E, JAN (EAN) 13, JAN (EAN) 8, Code 39, 1TF CODABAR	
	Extended	CODE128	
	2-D	QR, Maxi , PDF417	
Printing mode		Page mode, line model	

■ SPECIFICATIONS

Item		Specification	
Part Number		FTP-627USL431/435	FTP-627USL631/635
Interface		Conforms to USB / Serial	
Power supply	For print head	24 VDC average current, 0.5A (0.9A peak) (print ratio: 12.5%, print speed: 100mm/sec.)	
	For motor	24 VDC ±5%, 0.8 A maximum	
	For cutter	24 VDC ±5%, 1.1 A maximum	
	For logic	5 VDC ±5%, 0.2 A maximum	
Dimensions	Mechnism and board	101 x 114 x 139mm (WxDxH)	
Weight	Mechnism and board	Approximately 600g	
Life	Head	Pulse resistance: 100 million pulses/dot (under out standard conditions); Abrasion resistance: paper traveling distance	
		50km (print ratio: 12.5% or less)	100km (print ratio: 12.5% or less)
	Cutter	500,000 cuts (20 cuts/minute)	
	Platen	5,000 (open/close)	
MTBF	Mechanism	3,000 hours	
	Circuit board	500, 000 hours	
Operating environment	Operating temperature*	0°C to 50°C	
	Operating humidity	20 to 85% RH (no condensation)	
	Storage temperature*	-20°C TO +60°C (paper not included)	
	Storage humidity	5 to 90% RH (no condensation)	
Detection function	Head temperature detection	Detected by thermistor	
	Paper out /mark detection	Detected by photo-interuptor	
	Platen release	Detected by sliding switch	
Recommended thermal sensitive paper	High Sensitive Paper	TF50KS-E4 (Nippon paper)	
	Standard Paper	TF60KS (Nippon paper), FTP-020PU001 (58mm), PD105R (Oji paper), FTP-020P0701 (58mm)	
	Medium Life Paper	TF60KS-F1, FTP-020P0102 (58mm), PD170R (Oji paper), P220VBB-1 (Mitsubishi paper)	
	Long Life Paper	PD160R-N (Oji paper), AFB-235 (Mitsubishi paper), TP50KJ- R (Nippon paper), HA220AA (Nippon paper)	

*+5°C to +40°C printing density assurance rance.

■ FUNCTION OF INTERFACE BOARD

Item	Item
1. Test print function	8. Cutter trouble detect
2. Paper out detection	9. Motor power saving function
3. Paper near end detection	10. Mark detection function
4. Platen open detection	11. MCU operation abnormality detection
5. Thermal head temperature abnormality detection	12. Power ON/OFF sequence protection
6. Blow-out fuse detection	13. Motor over-current protection
7. Head voltage abnormality detection	14. Hardware timer

■ INTERFACE, COMMAND, OPTIONS

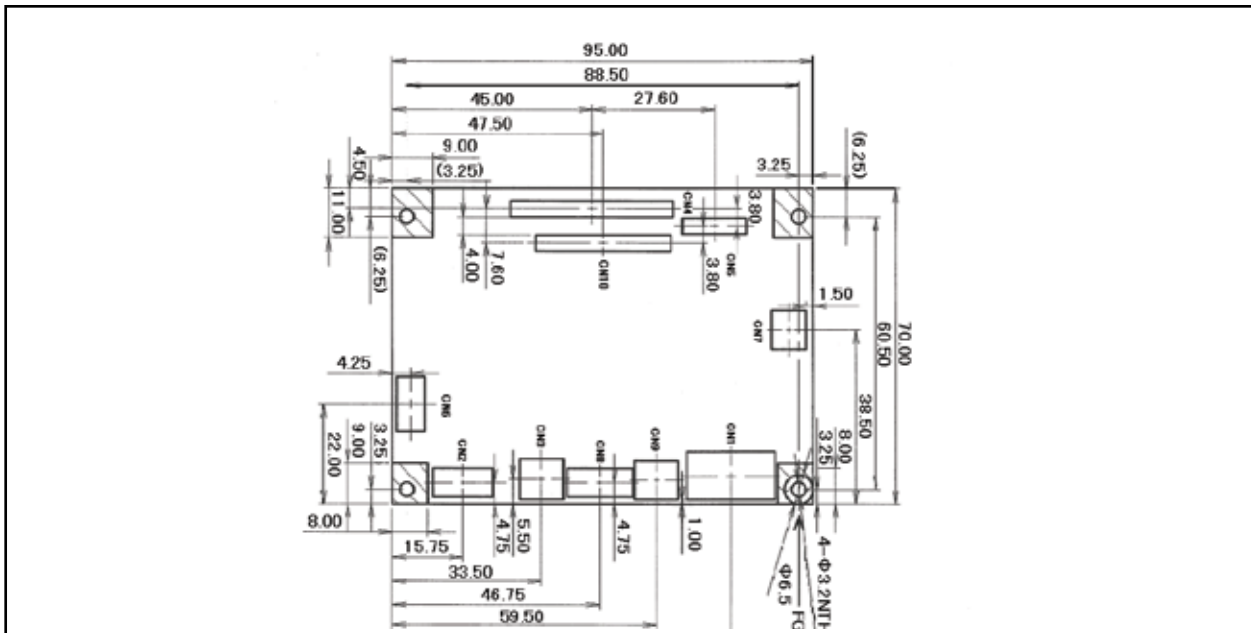

Connectors on Control Board

	Name	Functions	Remarks	Note
CN1	+24V power supply connector	Connection for +24V power supply		
CN2	RS-232C connector	Connection for serial interface		*2
CN3	USB I/F connector	Connection for USB interface		*2
CN4	-	-		
CN5	Cutter connector	Connection for paper cutter		
CN6	Operation panel connector	Connection for operation panel		*1
CN7	Near end sensor connector	Connection for near end switch		
CN8	-	-		
CN9	Logic power connector	Connection for +5V power Supply		*1
CN10	Head/motor connector	Connection for thermal head & paper feed motor	2-inch, 24 pin	

Note: *1: Option
*2: Depends on P/N

■ DIMENSIONS

1. FTP-627USL431/435

FTP-627 Unit Paper ø83

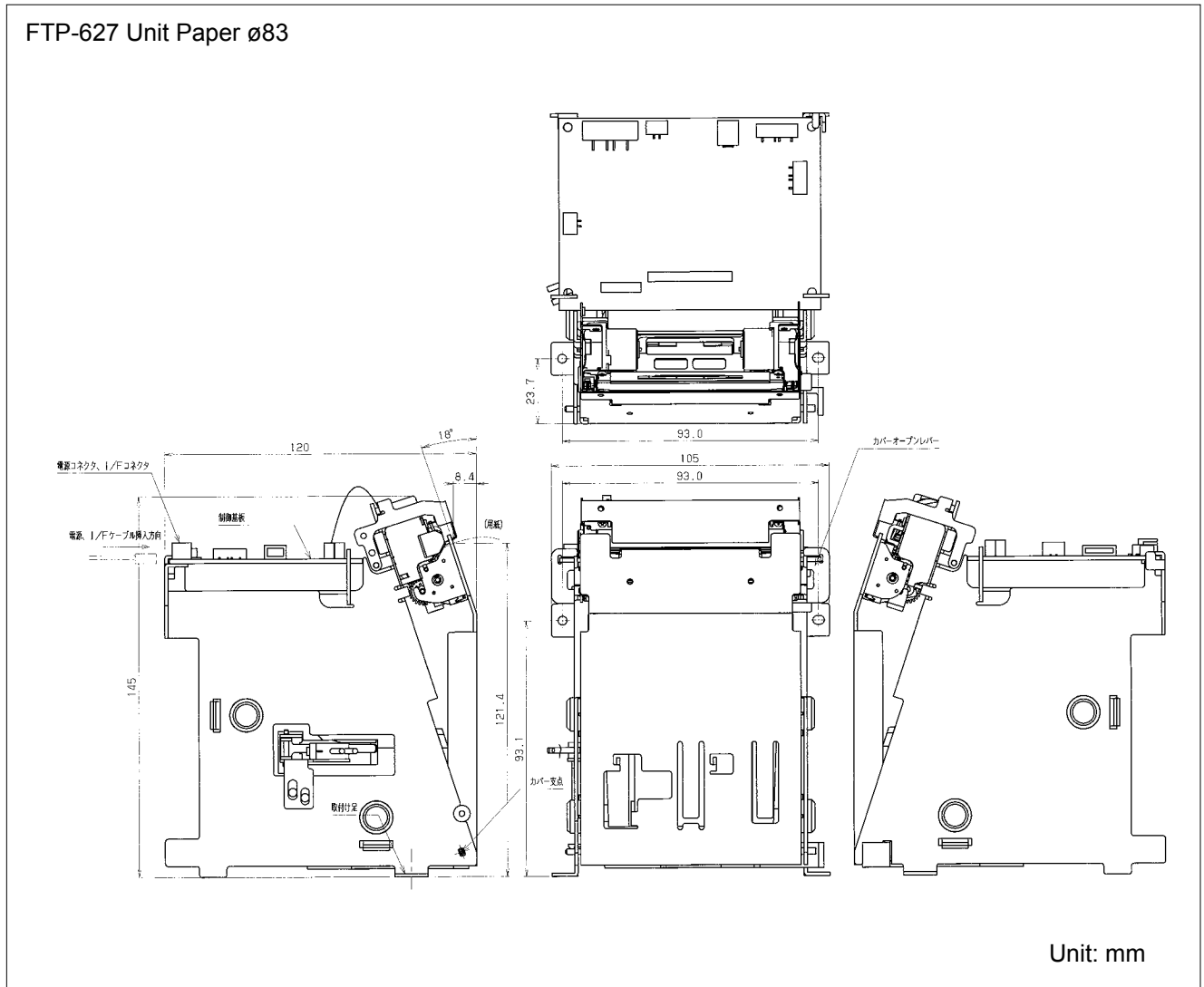

- Note: 1. The cable size and FPC are not included in this drawing.
 2. Do not mount anything in the shaded area except the printer.
 3. Connect to the body with 2 screws at 2 hooks.

■ COMMANDS

Command	Contents
HT	Moves print position to the next tab.
LF	Line feed.
FF	Feeds forms (new page).
ESC FF	Data printing in page printing mode.
ESC RS	Sets reverse printing.
ESC US	Resets reverse printing.
ESC SP+n	Character spacing setting.
ESC ! + n	Sets print mode.
ESC \$+n1+n2	Absolute position spacing.
ESC % + n	External registration character specification/cancellation.
ESC & +y+c1+c2+x+d1to dn	External registration character definition.
ESC *+m+n1+n2+d1+dN	Sets bit image mode.
ESC - +n	Undeline setting.
ESC 2	Sets 1/6 inch line feed length.
ESC 3+n	Sets the line feed length.
ESC ? + n	External registration character deletion.
ESC @	Printer initialization.
ESC A+n	Sets the space between the line.
ESC C+n	Sets the page length by character line.
ESC D+d1+dN +NUL	Sets the tab position.
ESC E+n	Highlighted printing specification/cancellation.
ESC J+n	Feeds paper in forward direction and prints.
ESC K+n	Print and reverse direction paper feed.
ESC L	Page printing mode selection.
ESC Q+n+!+j	Frame overlay function.
ESC R+n	Selects international character.
ESC S	Line printing mode.
ESC T+n	Print direction setting (only page mode).
ESC V+n	Right Rotation 90° specification / cancellation.

Commands continued

Command	Contents
ESC W+X1+X2+1+Y2+dX1+dX2+dX1+dY2	Page printing mode printing area setting.
ESC X+m+n	Setting the turning time of the motor excitation.
ESC Y+01h+ESC+x+a+m+d~	Program download.
ESC Y+n1+n2	Relative position setting.
ESC a+n	Positional alignment.
ESC c+1+n	Sets internal processing.
ESC c+5+n	Panel switch enable/disable setting.
ESC d+n	Printing and n-line feeding.
ESC e+n	n lines reverse feed.
ESC i	Full cut
ESC m	Partial cut
ECS s+n	Sets printing speed.
ECS t+n	Character code table selection.
ESC {+n	Sets/resets upside down printing.
ESC DEL+n	Flash memory delete
FS !+n	Kanji printing mode collective specification.
FS &	Kanji printing mode specification.
FS-+n	Kanji underline specification/cancellation.
FS *+ m+n1+n2+d1 to dn	High speed collective image printing specified.
FS .	Kanji printing mode cancellation.
FS 2+c1+c2+d1 to dn	External character definition.
FS 9+n	Sets the detection functions.
FS C+n	Kanji code system selection.
FS E+n	Correction of impressed energy.
FS S+n+n1+n2	Kanji spacing setting.
FS W+n	Kanji double height and width printing specification/cancellation.
FS r+n* ¹	Parameter transmission.
FS-r+n	Setting return parameter
GS!+n	Setting character size

Commands continued

Command	Contents
GS \$ + n1 + n2	Vertical absolute position specification in page printing mode.
GS & +m + x + y1 + y2 + d1 to dn	Registered bit image definition.
GS' + m + n	Registered bit image printing.
GS *+x+y1+y2 +d1+dn	Registered bit image definition.
GS/ +m	Registered bit image printing.
GS <	Line feeds to the next mark.
GS A+m+n	Sets the line feed length after mark detection.
GS B+m	Angle setting of bar code.
GS E+n	Sets print quality.
GS H+n	HRI character printing position selection.
GS L+n1+n2	Left margin position setting.
GS M+n	Printer ID demand.
GS W + n1 + n2	Printing area width setting.
GS Y +n1 + n2	Vertical relative position specification in page printing mode (vertical direction of characters).
G a+n	Automatic notification setting status.
GS e+n+m	Sets bar code width.
GS f + n	HRI character font selection.
GS h+n	Sets bar code height.
y) GS k+m +d1 to dk + NUL x) GS k+m+n+ d1 to dn	Bar code printing.
GS k+m+k1+k2+k3+k4+{[p1][d(1,1)] ~ [d(1,i)] ~ {[pi][d(i,1)]~[d(i,j)]} [00]16	Print of 2Dcode (QR).
GS k+m+k1+k2+k3+k4+k5+d1~dn	Print of 2 Dcode (maxi).
GS k+m+k1+k2+k3+k4+k5+k6+d1~dn	Print of 2 Dcode (PDF417).
GS v	Notification of firmware version.
GS w+n	Sets bar code length.
GS (+c+m1, n2, m+fn+6 +d1~dn	Customize printer

*1: These commands are valid with FTP-627DSL600 series.

Fujitsu Components International Headquarter Offices

Japan

Fujitsu Component Limited
Gotanda-Chuo Building
3-5, Higashigotanda 2-chome, Shinagawa-ku
Tokyo 141 8630, Japan
Tel: (81-3) 5449-7010
Fax: (81-3) 5449-2626
Email: promothq@fcl.fujitsu.com
Web: www.fcl.fujitsu.com

North and South America

Fujitsu Components America, Inc.
250 E. Caribbean Drive
Sunnyvale, CA 94089 U.S.A.
Tel: (1-408) 745-4900
Fax: (1-408) 745-4970
Email: components@us.fujitsu.com
Web: <http://us.fujitsu.com/components/>

Europe

Fujitsu Components Europe B.V.
Diamantlaan 25
2132 WV Hoofddorp
Netherlands
Tel: (31-23) 5560910
Fax: (31-23) 5560950
Email: info@fceu.fujitsu.com
Web: emea.fujitsu.com/components/

Asia Pacific

Fujitsu Components Asia Ltd.
102E Pasir Panjang Road
#01-01 Citilink Warehouse Complex
Singapore 118529
Tel: (65) 6375-8560
Fax: (65) 6273-3021
Email: fcal@fcal.fujitsu.com
Web: <http://www.fujitsu.com/sg/services/micro/components/>

©2009 Fujitsu Components America, Inc. All rights reserved. All trademarks or registered trademarks are the property of their respective owners.

Fujitsu Components America or its affiliates do not warrant that the content of datasheet is error free. In a continuing effort to improve our products Fujitsu Components America, Inc. or its affiliates reserve the right to change specifications/datasheets without prior notice.
Rev. February 27, 2009.