

# POINTING DEVICE

## PALM MOUSE™

### FID-824 SERIES



#### ■ FEATURES

- Hand held operation
- Long life and high reliability
  - No mechanical contact
  - Unique magnetic field detection technology
- Smooth operation
  - Light touch
  - Easy full-screen control
  - Stable operation in any direction

#### ■ MAIN APPLICATIONS

- Notebook computer
- Multi-media equipment
- GPS

#### ■ CONSTRUCTION

- With enclosure and interface cable

# FID-824 SERIES

## ■ SPECIFICATIONS

Item		Specification
Mechanical	Detection Method	Unique magnetic field detection technology
	Number of Switches	2 buttons
	Operation Force	200 gf (7.04 oz.) typ.
	Operating Life	1 M strokes min.
	Switch Life	1 M operations min.
	Weight	30 g (1.056 oz.) typ.
Electrical	Power Supply	+5 V $\pm$ 0.25 V DC, 20 mA max.
	Interface	Clock synchronous serial transmission (PS/2)
Environment	Operating Temperature	0 to 40°C
	Storage Temperature	-15 to 60°C
	Humidity	90% RH max. at +40°C max. inversely proportional change to 50% RH at 60°C

## ■ PARTS NUMBERS

Parts Number	Number of Switches	Interface	Connector	Color		
				Case	Cap	Switch
FID-824-511	2	Clock synchronous serial (PS/2)	Mini-DIN 6 pin	Light gray		
FID-824-512				Yellow	Green	Blue
FID-824-513				Green	Blue	Yellow
FID-824-514				Blue	Yellow	Green

## ■ CONNECTOR PIN ASSIGNMENT

Mini-DIN 6 pin

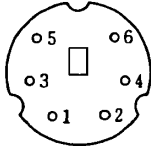

Pin number	Signal name
1	Data
2	—
3	GND (SG)
4	V <sub>cc</sub>
5	Clock
6	—

# FID-824 SERIES

## ■ DIMENSIONS

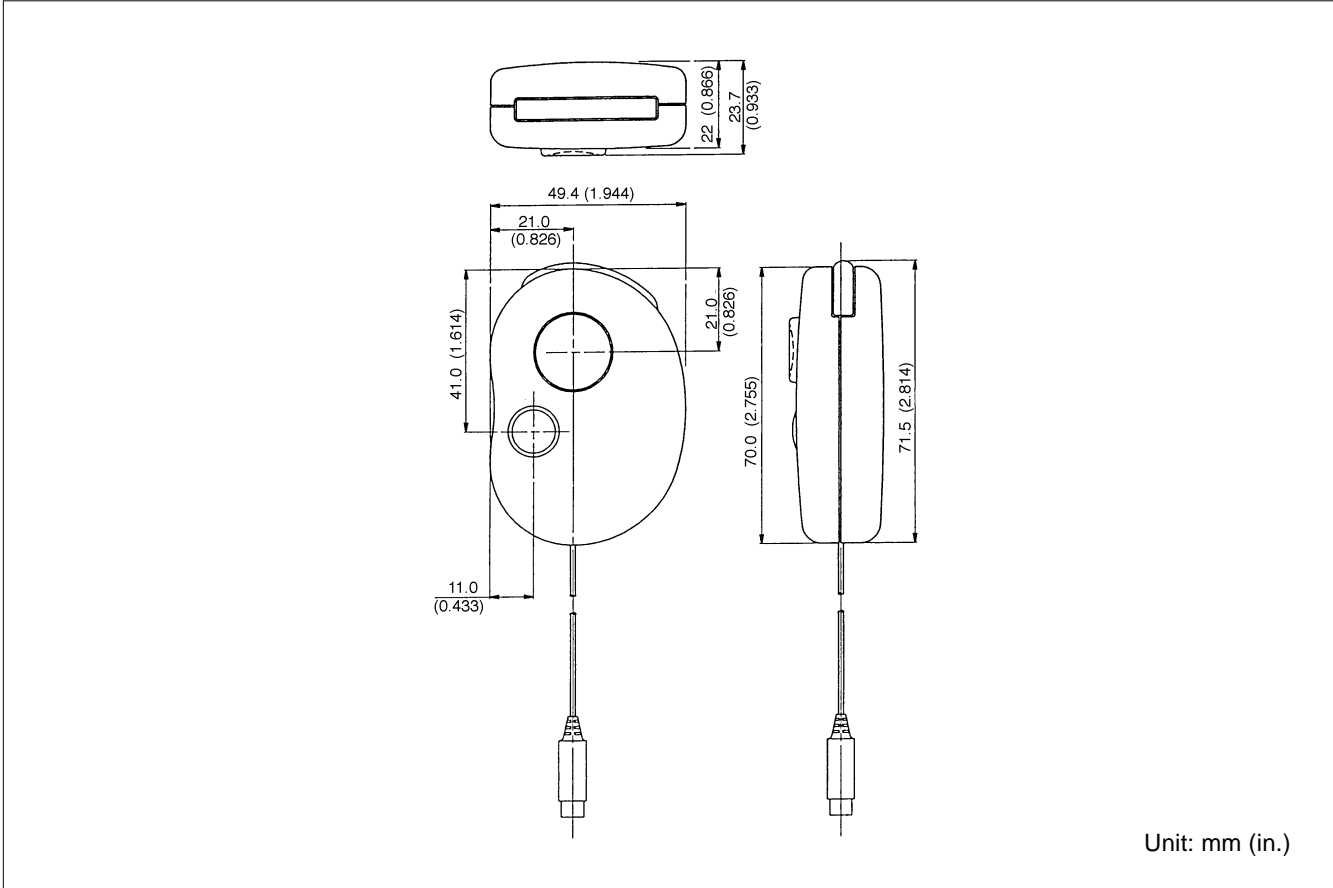

### Fujitsu Components International Headquarter Offices

**Japan**  
Fujitsu Component Limited  
Gotanda-Chuo Building  
3-5, Higashigotanda 2-chome, Shinagawa-ku  
Tokyo 141, Japan  
Tel: (81-3) 5449-7010  
Fax: (81-3) 5449-2626  
Email: [promothq@ft.ed.fujitsu.com](mailto:promothq@ft.ed.fujitsu.com)  
Web: [www.fcl.fujitsu.com](http://www.fcl.fujitsu.com)

**North and South America**  
Fujitsu Components America, Inc.  
250 E. Caribbean Drive  
Sunnyvale, CA 94089 U.S.A.  
Tel: (1-408) 745-4900  
Fax: (1-408) 745-4970  
Email: [marcom@fcai.fujitsu.com](mailto:marcom@fcai.fujitsu.com)  
Web: [www.fcai.fujitsu.com](http://www.fcai.fujitsu.com)

**Europe**  
Fujitsu Components Europe B.V.  
Diamantlaan 25  
2132 WV Hoofddorp  
Netherlands  
Tel: (31-23) 5560910  
Fax: (31-23) 5560950  
Email: [info.marketing@fceu.fujitsu.com](mailto:info.marketing@fceu.fujitsu.com)  
Web: [www.fceu.fujitsu.com](http://www.fceu.fujitsu.com)

**Asia Pacific**  
Fujitsu Components Asia Ltd.  
102E Pasir Panjang Road  
#04-01 Citilink Warehouse Complex  
Singapore 118529  
Tel: (65) 375-8560  
Fax: (65) 273-3021  
Email: [fcal@fcal.fujitsu.com](mailto:fcal@fcal.fujitsu.com)  
[www.fcal.fujitsu.com](http://www.fcal.fujitsu.com)

© 2001 Fujitsu Components America, Inc. All company and product names are trademarks or registered trademarks of their respective owners. Rev. 09/2001