

ITS Sensor for Railroad Crossing Safety

● Tetsuo Horimatsu

(Manuscript received October 5, 2006)

Japan's Intelligent Transport Systems (ITS) project for safe and comfortable transportation is steadily progressing. To improve safety, information technology (IT) should be applied to most of Japan's traffic environments. In response, the Fujitsu Group has installed IT equipment into motor vehicles in line with a government policy of using IT to bring transportation systems fully into the 21st century. The Group has also developed a millimeter-wave radio ITS sensor that can drastically reduce accidents on railroad crossings. The sensor can detect objects such as people, cars, bicycles, and wheelchairs over a wide area of a crossing. This paper outlines the features of the new sensor and its associated IT system, the development of the sensor, and some applications of this technology.

1. Introduction

Information technology (IT) is essential for making Japan's transportation system safe and convenient. In Japan, the Intelligent Transport Systems (ITS) project¹⁾ has been undertaken to reduce traffic accidents and renew the nation's traffic environments.

In addition to the measures requested by the government's IT Strategy Headquarters in 1996, various types of IT have started to be applied to the traffic environment. The Fujitsu Group has developed a system for safe and smooth driving that measures the distance between vehicles in front and behind using millimeter-wave radar.^{2),3)}

Also, Fujitsu has installed this sensor in areas that experience heavy snowstorms and started tests for preventing multi-vehicle accidents.⁴⁾

Fujitsu has been developing a new system for railroad operation safety based on new sensors that are in practical use. The system will be installed at various crossings, starting from the

end of 2006.

Conventional sensors at a railroad crossing detect only large vehicles using beams of infrared light and sound an alarm if such a vehicle remains on the crossing. The new sensors, on the other hand, also detect pedestrians, wheelchairs, and bicycles across a wide area using a much more sophisticated targeting system.

In this paper, we describe a millimeter-wave sensor we are developing to reduce the number of railroad accidents, especially at railroad crossings. We also describe an experimental application of this sensor and some possible applications in the future.

2. Safety at railroad crossings and practical use of millimeter-wave sensor

2.1 Safety at railroad crossings

There are about 30 000 major railroad crossings in Japan, and each of them has various sensors and alarm devices to prevent accidents

between trains and the vehicles, bicycles, pedestrians, and wheel chairs that pass over them.

However, in response to the large number of railroad crossing accidents that have occurred recently, the Ministry of Land, Infrastructure and Transport has set up a technical research group — primarily composed of railway signal manufacturers — with the aim of deploying a new sensor system to prevent accidents.

Fujitsu has supported this project indirectly, by using its technologies and know-how accumulated through practical use of in-vehicle millimeter-wave radar and by working on the development of a millimeter-wave sensor for ensuring a higher degree of safety.

Figure 1 shows the concept of a railroad crossing system that uses millimeter-wave sensors. Up to 10 infrared beams are used for a small railroad crossing, and over 10 are used for wider railroad crossings. These systems sound an alarm if a beam is blocked for a certain period of time, indicating that a vehicle has become immobile on the crossing.

However, this sensing method misses objects located between the beams. Also, false detections and non-detections have occurred due to car headlights and weather conditions such as rain, fog, and snow. To compensate for these faults, the technical research group decided to use new millimeter-wave sensors that have entered practical use, targeting them for operation by 2006.

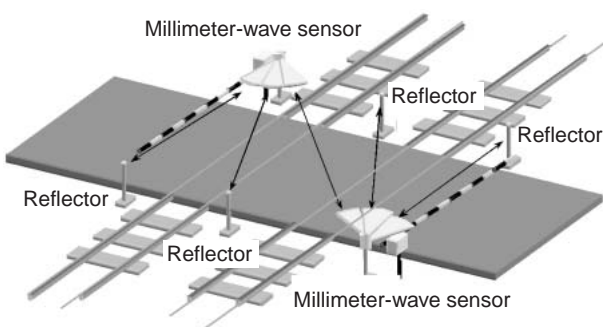

Figure 1
Railroad crossing system using millimeter-wave sensors.

2.2 Practical use of millimeter-wave sensors

The millimeter-wave sensors operate at 60 to 61 GHz or 76 to 77 GHz; they have been in development since the 1970s and in practical use since the late 1990s for ITS applications.

These sensors are mostly used in Adaptive Cruise Control (ACC) systems,^{2),3)} which are in-vehicle devices for safe and comfortable transportation whose shipment numbers have been steadily increasing.

Figure 2 (a) shows the basic block diagram of a millimeter-wave sensor.⁵⁾ The sensor consists of an antenna, millimeter-wave receiver-transmitter, analog circuitry, digital signal processor, communication interface, and power supply.

The circuit configuration varies depending on the radar method in use. In the frequency modulated-continuous wave (FM-CW) method, which is the most commonly used worldwide, the millimeter-wave transmission is frequency modulated and the signal reflected from the target is compared to the original signal using analog processing to determine the relative speed and distance to the target [**Figure 2 (b)**].

The new signal processing technology ensures that targets are captured regardless of the ambient electromagnetic environment. In addition to enhancing hardware reliability and performance, it also plays an important role in putting the sensor into practical use. Also, it was essential to develop a technology that enabled us to provide reasonably priced products.

As a result of our development efforts, we have realized stable performance, and more than 20 000 of these millimeter-wave sensors are now installed in passenger vehicles.

Current in-vehicle sensors detect targets between 4 and 120 m away because they are designed to detect objects in front of a vehicle. However, this limits the distance-detecting accuracy to several m. Therefore, it is difficult to use these sensors in a railroad crossing system because they need to detect pedestrians, wheel-

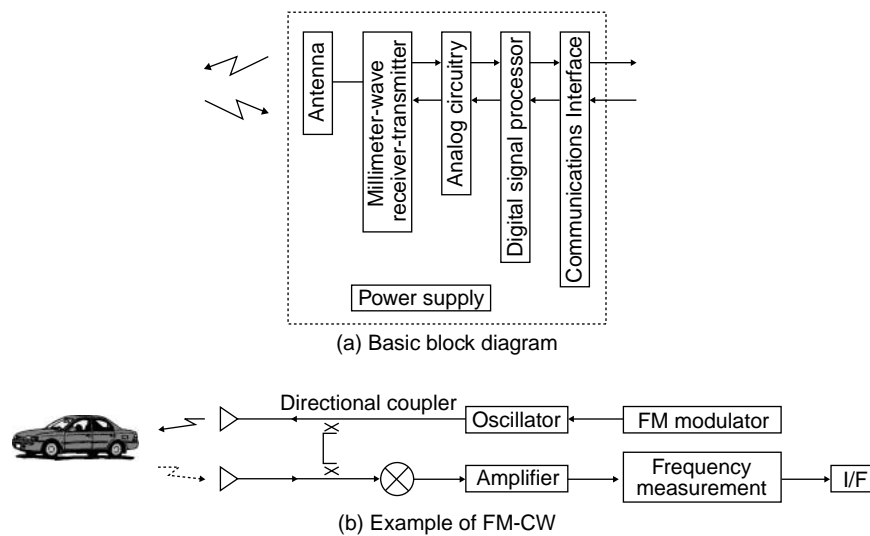

Figure 2
Block diagram of millimeter-wave sensor.

chairs, and bicycles separately from other objects located inside and outside of the crossing.

To overcome this problem, we developed the pulse sensor, the operation of which is described below.

2.3 Sensor operation

Figure 3 (a) shows the diagram of the pulse-sensor.^{6),7)} A square wave is generated from the oscillator and input to the pulse generator. The pulse generator outputs a pulse train with a 4% duty ratio as a control signal and a millimeter-wave ASK-modulated carrier of 76 to 77 GHz.

The modulated carrier is input to the antenna, which transmits a radio signal with the required beam pattern. The transmitted pulse train is reflected by the target, received by the receiving antenna, amplified, and then mixed with the original carrier and homodyne-detected.

As shown in Figure 3 (a), if there are multiple objects (in this case, two vehicles with different shapes positioned at different distances) in front of the sensor, the reflected signals from the objects reach the receiving antenna at different times and the detected signal is a multi-object envelope repeated at the same rate as the transmitted signal.

The transmitted pulses are 3 to 5 ns wide, so the A/D converter, which has a sampling rate of more than 500MHz, must process the signal using the conventional method of directly converting analog signals into digital ones.

Instead of using an expensive high-speed circuit, the sensor we developed uses a novel method of signal processing [**Figure 3 (b)**]. The detected signal described above is input to the gating circuit, which alternately passes the signal and then blocks it at the transmission rate and with a delay determined by a microcomputer.

Because of this gating, the pulse sensor only produces an output when the gating delay matches the time lag between the transmitted and received signals. Therefore, the distance to a target can be determined from the gating delay. This method enables a low-speed A/D converter to be used, which simplifies the circuit and reduces the cost of the device.

2.4 Sensor performance

The specifications and a photograph of the pulse sensor are shown in **Figure 4**. It is designed to be installed around railroad crossings and along the roadside.

To use development resources efficiently,

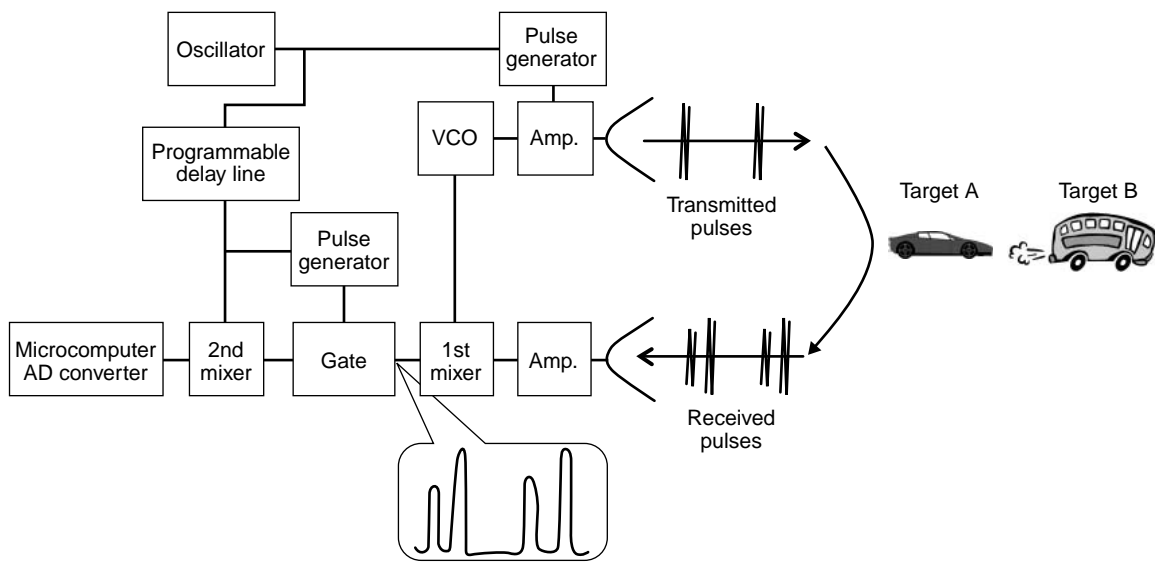

(a) Block diagram

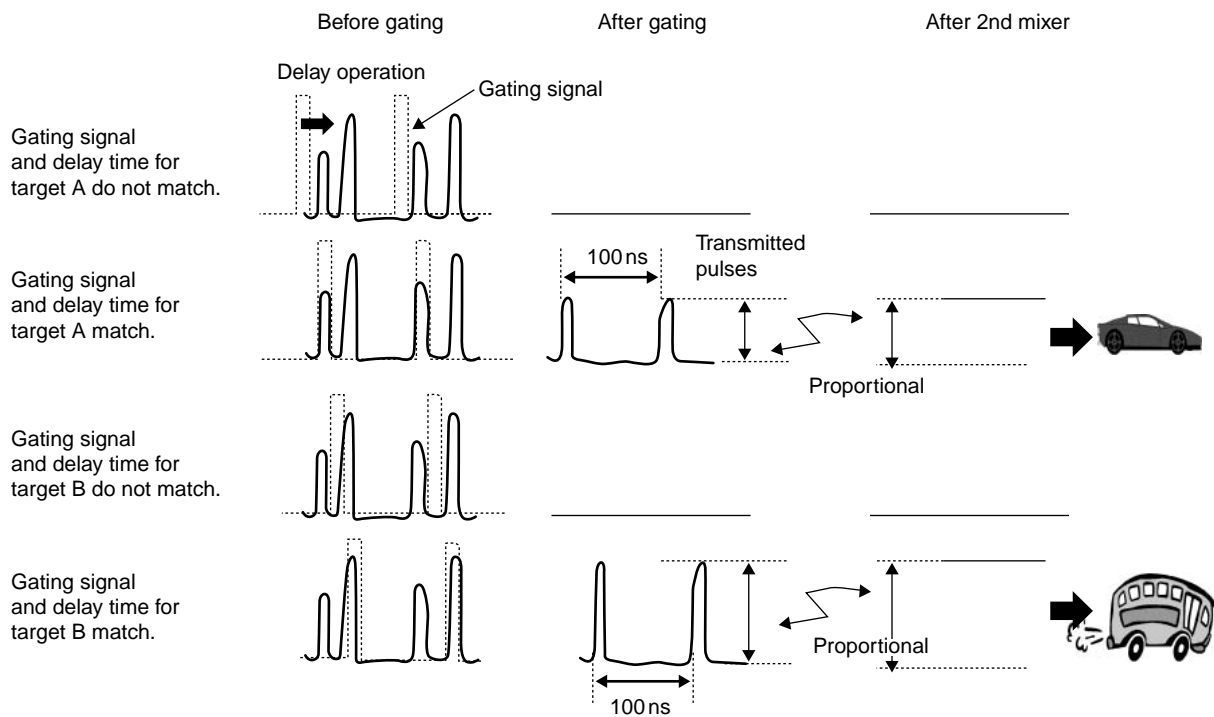

(b) Operation

Figure 3
Block diagram and operation of pulse sensor.

Item	Specification
Transmitter frequency	76 to 77 GHz
Output power	Less than 10 mW
Radar method	Pulse radar
Antenna	Flat-panel antenna
Detection distance	0.1 to 14 m



Figure 4 Specifications and photograph of pulse sensor.

we used the same monolithic millimeter-wave integrated circuits (MMICs) and printed circuit boards as are already used in in-vehicle radar devices.

However, the specifications of a sensor for railroad crossings are different from those for in-vehicle ACC. A sensor for railroad crossings must detect objects up to 14 m away, which is shorter than the detection distance of an in-vehicle radar. It must also detect over a wider area of 30 degrees as well as detect multiple targets with a distance resolution of less than 50 cm.

The operating frequency range is the international standard of 76 to 77 GHz, and the maximum transmitter output power is less than 10mW. Therefore, because it has a Technical Standards Adaptation Certificate, it can be used anywhere in Japan without a license.

The measured distance errors for up to 13 m are shown in **Figure 5**. When a corner reflector with a reflection cross section of 5 dBsm is set within 14 m, the distance measurement error for transiting objects is in the millimeter order. As the figure shows, the maximum error is about 24 cm.

The measured distance between two adjacent corner reflectors (CRs) about 40cm apart is shown in **Figure 6**. The vertical axis shows the detection level, and the horizontal axis shows the detected distance. Two peaks were detected at 5.10 m and 5.48 m, confirming that the two objects were separately detected. The measured distance between the two CRs is 10 times more

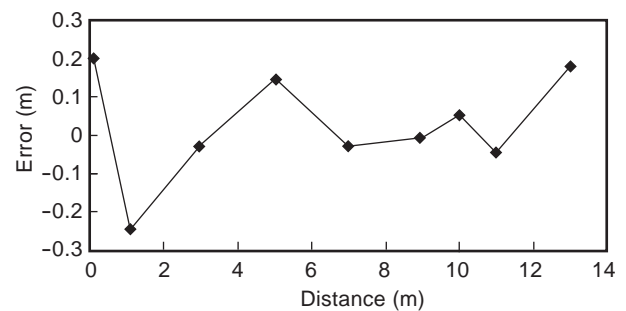

Figure 5 Distance measurement error.

accurate than the results that can be obtained using traditional FM-CW radar.

3. Experimental and future applications

Figure 7 shows an experimental application of the pulse sensor. In this experiment, the sensor was able to detect a wheelchair on a railroad crossing.

There were various features that reflected the millimeter-wave signal, including the railroad rails, that might have hidden the wheelchair. However, as described above, our sensor can discriminate objects that are less than 40cm apart and clearly discriminated the wheelchair from the surrounding features. The sensor therefore is able to detect immobilized wheelchairs and pedestrians on this railroad crossing.

This sensor was developed to reduce accidents at railroad crossings and can accurately measure the distance between multiple targets. Because its distance-measuring accuracy is

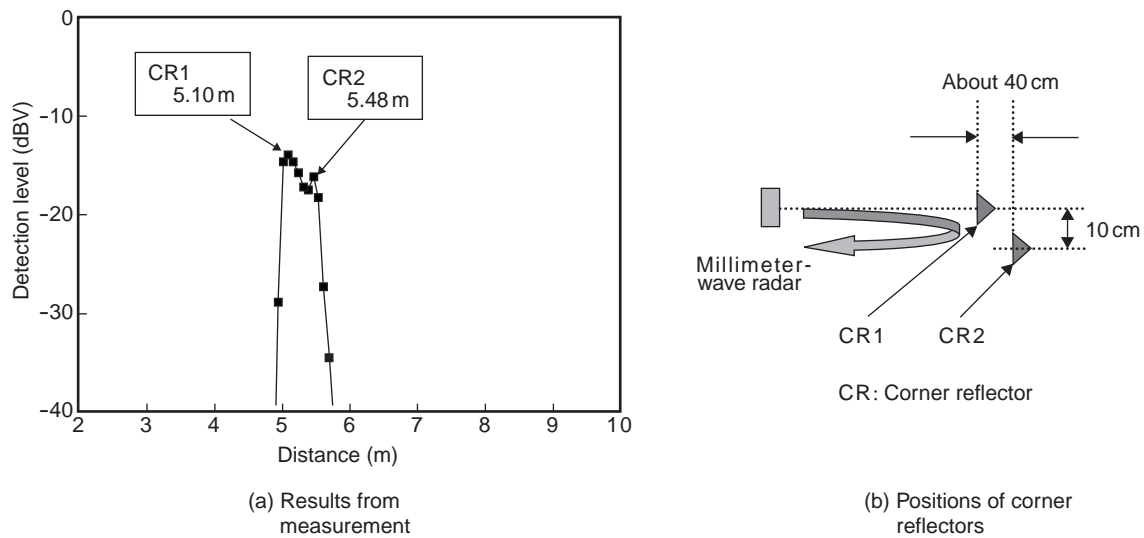

Figure 6 Measured distances of two adjacent targets.



Figure 7 Experimental system application.

superior to that of traditional millimeter-wave sensors, it can extend the application of this technology to other areas. For example, millimeter-wave sensors are starting to be used for monitoring roads in cold climates, and our sensor could be used to detect pedestrians hidden behind ploughed snow at intersections and then notify drivers of their presence via an infrastructure system. This sensor can also be mounted near the rear fender of a passenger vehicle to check for stationary and moving vehicles, pedestrians, and

bicycles over a wide area.

It can also be used, for example, on a vehicle to prevent collisions with pedestrians and shopping carts while reversing out of a parking spot.

We expect this sensor will be applied to a dramatically expanding range of applications.

4. Conclusion

This paper described an in-vehicle millimeter-wave sensor we developed. It also described the operation and experimental use of a new millimeter-wave pulse sensor we developed for dramatically reducing the number of railroad crossing accidents.

Traditional sensors at railroad crossing use beams of infrared light and can only detect large vehicles. The new sensor, on the other hand, can also detect pedestrians, bicycles, and wheelchairs over a wide area. The new sensor uses a new millimeter-wave radar method to meet the operational requirements of a railroad crossing environment.

We expect the new sensor will be very useful for improving railroad and road safety, especially for drastically reducing the number of tragic accidents at railroad crossings, which has been high in recent years.

References

- 1) Government's IT Strategy Headquarters: New IT Reform Strategy — The realization of a society, in which everyone can benefit from IT, anytime and anywhere. (in Japanese), January 19, 2006. <http://www.kantei.go.jp/jp/singi/it2/kettei/060119honbun.pdf>
- 2) T. Horimatsu et al.: The millimeter-wave radar systems that have been practically used. (in Japanese), *Journal of the Institute of Electronics, Information and Communication Engineers*, **87**,9,p.756-759 (2004).
- 3) N. Okubo: Millimeter-Wave Automotive Radar MWE' 96. Microwave Workshop & Exhibition Digest, 1996, p.370-375.
- 4) T. Tamura: One prospect regarding the collection and the utilization of the information for traffic environment on the roads in cold district. (in Japanese), Cold District ITS Workshop, Sapporo Convention Center, The Second Session-2, 2005.
- 5) T. Horimatsu et al.: The basics and applications of millimeter-wave technology. (in Japanese), Realise Inc. 1998.
- 6) T. Horimatsu et al.: Millimeter-wave Sensor in Practical Use. MWE' 05, Microwave Workshop & Exhibition Digest, WS16-01, 2005.
- 7) S. Ishii et al.: The sensing properties of millimeter-wave pulse radar. (in Japanese), 2005, Institute of Electronics, Information and Communication Engineers Engineering Sciences Society, AS-3-1, 2005.



Tetsuo Horimatsu, Fujitsu Ltd.

Mr. Horimatsu received the B.S. and M.S. degrees from Tokyo Institute of Technology in 1972 and 1974, respectively. In 1974, he joined Fujitsu Laboratories Ltd., Kanagawa, Japan, where he was engaged in research and development of systems and devices for optical and radio communications. In 1996, he was transferred to Fujitsu, Ltd., Kanagawa, Japan, where he has been

engaged in planning and development of the Intelligent Transportation Systems (ITS) as chief scientist. He is a member of the Institute of Electronics, Information and Communication Engineers (IEICE) of Japan. He received the Best Paper Award from the IEICE in 1995.

E-mail: thori@jp.fujitsu.com