

# Fujitsu's Third-Generation Optical Transport Solution for Metro Optical Networks: FLASHWAVE 7500

● Hiroyuki Matsumoto ● Hatsumi Iino ● Stephen Carlton

*(Manuscript received April 20, 2006)*

Until recently, telecommunications transport networks have been built using SONET/SDH transmission equipment. Carriers have anticipated the advantages that metro optical networks (MONs) promise, but available equipment has a number of disadvantages and deployment has been limited. Fujitsu has developed a third-generation optical transport system called FLASHWAVE 7500 Release 4.1 (R4.1). This product overcomes many of the problems of previous generations of MONs. The FLASHWAVE 7500 R4.1 will enable carriers to cost effectively build networks to carry large amounts of traffic of any type. It will greatly simplify traffic engineering and span engineering, enabling more efficient network configurations. This paper briefly describes the history of optical networks, the technologies used in these networks, and how the issues encountered by previous generations have been overcome.

## 1. Introduction

Fiber optic transmission has been used in telecommunications networks since the late 1970s. It was initially used to extend span distances, save fiber, and eliminate expensive electrical repeaters. These uses were enabled by improvements in lasers and the development of erbium-doped optical fiber amplifiers (EDFAs).<sup>1)</sup> Additionally, filter and grating component developments allowed wavelength multiplexing, which places multiple wavelengths on a single fiber, to support the increased demand for bandwidth. For almost 30 years, practical optical applications were restricted to long-haul, high-bandwidth transmissions.

The cost of long-haul transmission was very high due to the high cost of fiber, electrical regeneration, and maintenance, and these costs made it easy to justify the use of optical technologies based solely upon the savings achieved. While optical technologies showed great promise in metro optical networks (MONs), the requirements of a MON are quite different from those of a long-

haul network, and the technologies developed for long haul did not readily transfer to MON networks. Initial metro applications started in the late 1990s, but typically used point-to-point Dense Wavelength Division Multiplexing (DWDM) and were used where fiber capacity was full and new construction costs were high.

This paper describes the history of optical networks. We have developed a third-generation optical transport system to overcome many problems of previous generations of MONs. This paper also introduces how the issues encountered by previous generations have been overcome.

## 2. MONs

MONs have stringent requirements, for example, they require the ability to add and drop wavelengths from nodes around a ring. They are also sensitive to equipment and operating costs. Two important technologies in MON design and operation are span engineering and traffic engineering. Span engineering, which is the design of optical parameters, needs to be simple. Traffic

engineering, which is used to decide where traffic is added and dropped, not only needs to be simple but also flexible to meet the distributed and varying traffic demands in a MON. The physical changes required to add and drop wavelengths must be easy to make and should not affect channels already on the network. Many different types of traffic and services need to be carried on a ring, and more advanced networks need the ability to optically pass traffic from one network to another. The two over-riding requirements for a MON are low cost and simplicity.

1) First generation.

Improvements in optical technology in the late 1990s resulted in lower amplifier costs and new devices such as fiber Bragg gratings. These improvements enabled new system architectures and brought the first generation of systems designed specifically for metro applications. The key features of these first products were their ability to add and drop wavelengths from a fiber and be interconnected to form rings. These systems were called optical add drop multiplexers (OADMs).

Typically, wavelengths were dropped in bands (also called groups) using band reject filters. Banding made traffic engineering difficult because changing whether a band was added or dropped required manual manipulation and re-arrangement of fibers. Also, when such changes were made, the span engineering for other channels could change. These systems are sometimes called partial or banded OADMs.

Because these systems required manual intervention at every site, service changes were slow and expensive. Their wavelength spacing was typically only 200GHz, resulting in low channel counts and hence high costs. As a result, fiber addition in a metro area or SONET overlay was always cheaper, except where conduit exhaust required very long fiber routes or extensive and difficult physical builds. As a result of these limitations, this first generation was not heavily deployed.

2) Second generation.

Optical technologies continued to evolve at a rapid pace, and within a few years devices were improved or developed to overcome the limitations of the first generation. Using these new devices, a new generation of systems was developed, including the FLASHWAVE 7500 series from Fujitsu. The main features of this second generation were removal of wavelength banding, closer channel spacing, and a switch fabric that can reconfigure wavelengths without manual intervention. Amplifiers were also improved and allowed changes to be made within a network without affecting other channels; this greatly improved span and traffic engineering, thereby reducing the operational cost of the first-generation systems. These systems are called re-configurable add drop multiplexers (ROADMs).

Although improved, this generation still had limitations. Cable television companies adopted them because they had no existing SDH/SONET network and also had simpler requirements than telecommunications carriers. These systems also saw use in private enterprise rings and storage applications, but market penetration although growing was still low. This generation was unable to break the hold of SONET/SDH transport products on the core networks of large companies.

3) Third generation.

New devices that address many of the limitations of first-generation and second-generation systems are becoming available. Fujitsu has chosen a device called a wavelength selectable switch (WSS) as the core of its next-generation products. This device improves on the switch fabric in second-generation systems. The WSS performs the traditional switching and also performs channel power balancing and can switch traffic between multiple rings.<sup>2)</sup> This device enables new network configurations such as hubs and meshes, which gives network planners a high degree of flexibility.

Another dramatic new development in opti-

cal communications is the use of lasers that can be tuned across the full range of wavelengths,<sup>3)</sup> allowing users to dynamically reconfigure wavelengths within a system. The WSS has the unique ability to allow any input port to accept or drop any wavelength (each port in a typical second-generation system is dedicated to a specific wavelength). When full-band tunable lasers are used with the WSS, a line card can operate at any wavelength. This greatly improves the time to market for new services and simplifies network planning. Fujitsu has coined the term “dynamic optical add-drop multiplexer” (DOADM) to describe this configuration.

Carriers have previously separated different service types onto their own networks [Figure 1 (a)]. Each service is managed by a different group within a carrier, and each group has its own requirements and often requests vastly different topologies than the other groups. This has resulted in a multiplicity of networks, each being managed and operated separately, which is inefficient and expensive. Typical service networks are voice telephony, ATM/FR, wireless traffic, high-speed data, business enterprise data, and storage. Large carriers are also starting to deploy broadcast and video-on-demand services, like multiple system operators (MSOs) did with previous-generation systems.

Typically, third-generation networks support a feature called hubbing that allows several rings or mesh networks to be supported from a single hub with an optical interconnect between each ring [Figure 1 (b)]. Previous systems required back-to-back transponders to switch between different ring systems, which increased cost and added failure points. Hubbing allows multiple networks, each with its own service type, distribution, and operations, to be supported on a single network element with no cost penalty. Collapsing multiple networks onto a single system is called convergence.

Each service uses its own wavelengths independently from others and therefore operates as

a separate virtual network. This hubbing feature also allows new networks called mesh networks to be supported. Mathematical studies have shown mesh networks to be much more efficient than today's ring-based networks for some

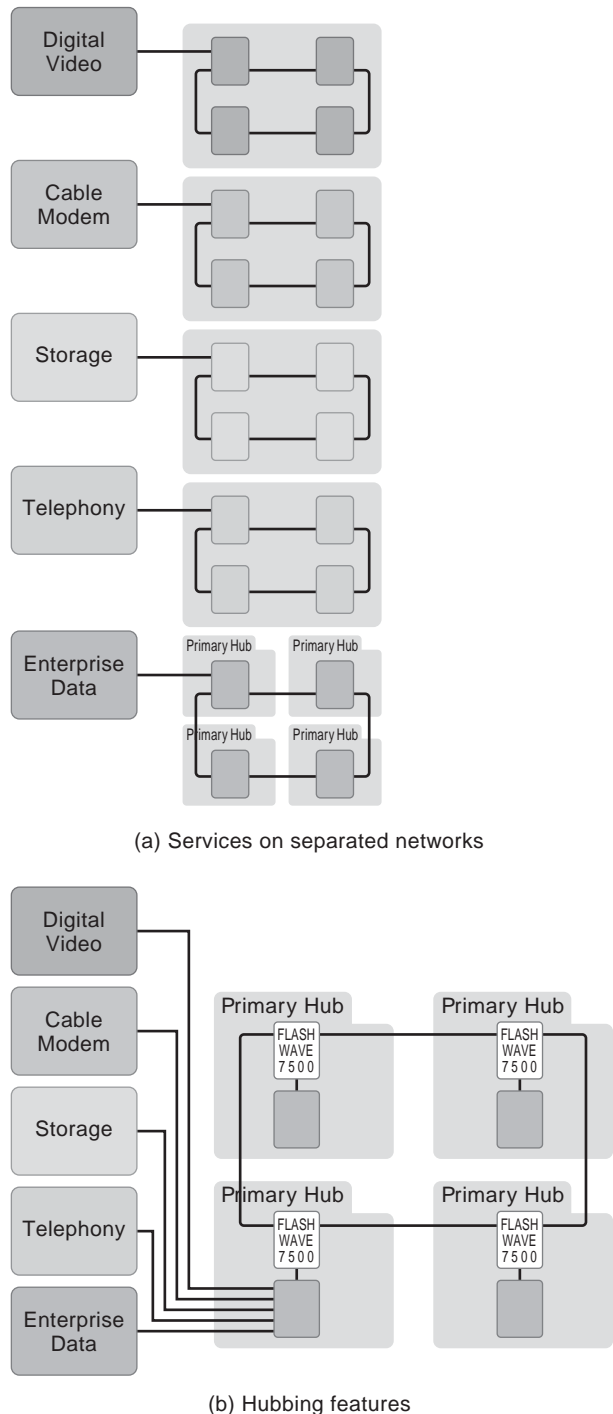

Figure 1 Overlay networks and convergence.

applications. More efficient equipment utilization leads to lower capital costs, and a highly connected network allows more efficient routing of different traffic types.

For new optical systems to replace existing equipment, they must not only do everything that today's equipment can do, but must also offer lower costs, new features, and other advantages. The increased competition between cable companies and traditional large carriers and recent advances in technology have led to a tipping point that will push DWDM deployments past the second generation and into the third generation and beyond. Fujitsu is well positioned to respond to this trend with its third-generation DWDM system and is already preparing it for migration to the fourth generation.

### 3. FLASHWAVE 7500 Release 4.1 architecture

Fujitsu has developed a third-generation optical transport system called the FLASHWAVE 7500 Release 4.1 (R4.1) (**Figure 2**).

To develop this next-generation product,



Figure 2  
FLASHWAVE 7500 R4.1 front view.

Fujitsu looked at the following new technologies and the differing requirements of each type of service and network:

#### 1) Wavelength selectable switch (WSS)

This device has a single fiber input that can carry up to 40 wavelengths. A grating is used to separate the wavelengths, and each wavelength is directed onto its own movable mirror. This allows automatic power management of each wavelength and switching of individual wavelengths to selected output fibers. The WSS can also work in reverse; that is, it can direct 40 separate signals of different wavelengths into a single fiber. It enables many new features to be provided in optical systems, and some of these are described in more detail below. Also, this device has lower losses than previous devices, allowing longer spans and more nodes to be placed on a ring. Moreover, it exhibits excellent filter shapes and passbands, which lowers penalties due to filter narrowing and forms a platform for future 40 Gb/s support.

#### 2) Amplifiers

Improved amplifiers automatically adjust the power levels at each node. They also use a high-speed gain control circuit and feed-forward techniques to minimize power transients when wavelengths are added or deleted or when a fiber is cut or removed to prevent impact on other data being carried through the system.<sup>4)</sup> These features allow simple network design and span engineering of a network that can grow from a few service channels to all the wavelengths been used.

#### 3) Full-band tunable lasers.

These lasers can be tuned across all the wavelengths in the optical band being used. This allows dynamic changing of wavelengths and a feature Fujitsu calls DOADM.

#### 4) Flexponders

These are tributary service cards that can multiplex channels onto a single wavelength and provide protection switching and grooming of traffic between two cards. These cards are some-

times called an "Add Drop Multiplexing (ADM) on a card" because they provide all the functionality of a SONET/SDH multiplexer system, which typically requires multiple cards in a shelf. These cards eliminate the need for separate boxes to support ADM features. They have in part been made possible by the latest high-gate-count ASIC technologies.

5) Forward error correction.

In forward error correction, data is divided into blocks and mathematical techniques are used to generate forward error correction codes, which when transmitted with the original data allow the receiver to discover and correct errors in the data.<sup>5)</sup> Although this increases the transmission bandwidth, it can improve optical performance and overcome many fiber and component limitations. Error correction techniques are used to offset optical impairments, increase span lengths, and allow more nodes to be placed on a ring.

FLASHWAVE 7500 R4.1 is a new system architecture that leverages these new technologies to create a simple, cost effective, and yet highly flexible system that can meet the needs of multiple networks within a single network element.

The basic architecture is shown in **Figure 3** and is described below.

Traffic enters the system via transponder cards. The cards convert the signal to a suitable rate, apply error correction protocols, and modulate a laser and tune it to a user-selected wavelength. In previous generations, different transponders were required for each service type and for each service rate. This led to a large number of transponder card types. Also, each wavelength required its own preset laser, which further increased the number of unique card types. As a result, there are severe inventory issues for vendors and customers. In contrast, FLASHWAVE 7500 R4.1 transponder cards, which use the latest high-gate-count ASIC technologies, can carry a variety of services, operate at various bit rates, and use a full-band tunable laser. This

means that a single card can replace the large number of cards that were previously needed. Specifically, FLASHWAVE 7500 R4.1 has reduced the types of transponder cards from the more than 80 needed in of previous releases to just a few. One of these flexible cards, the Flexponder, can carry multiple services by provisionable setting of OC-3/12/48, STM-1/4/16, and/or GbE data; operate at 10G service rates; and work at any of the ITU grid wavelengths in the C-band. To further increase flexibility, the shelf used in FLASHWAVE 7500 R4.1 has un-committed slots, so a transponder card can be placed in any service slot. This gives the user flexibility on how to arrange traffic and also can reduce the total number of shelves required in some configurations.

The signal from a transponder is connected through a multiplexer unit that combines up to 40 individual channels into a single 40-channel signal. The 40-channel signal is then passed through the WSS for power balancing and combination with the through and hubbed traffic. The final 40-channel signal is amplified before being placed on the line fiber.

To further increase flexibility and reduce operating costs, FLASHWAVE 7500 R4.1 can accept wavelengths directly from other systems without using a transponder card if the signal meets the system's optical performance requirements. Wavelengths added in this manner are called alien wavelengths because they originate outside of the system.

The entire system is duplicated, and the node has two identical paths going in opposite directions. For clarity, only one path is shown in Figure 3. Typically, one direction is called east and the other called west. If a single wavelength is to be protected, then two transponders are used to create two identical optical signals: one is passed to an east-exiting fiber, and the other is passed to a west-exiting fiber. At the destination node, the receiving transponders select the better of the two signals and so provide protection. FLASHWAVE 7500 R4.1 can carry

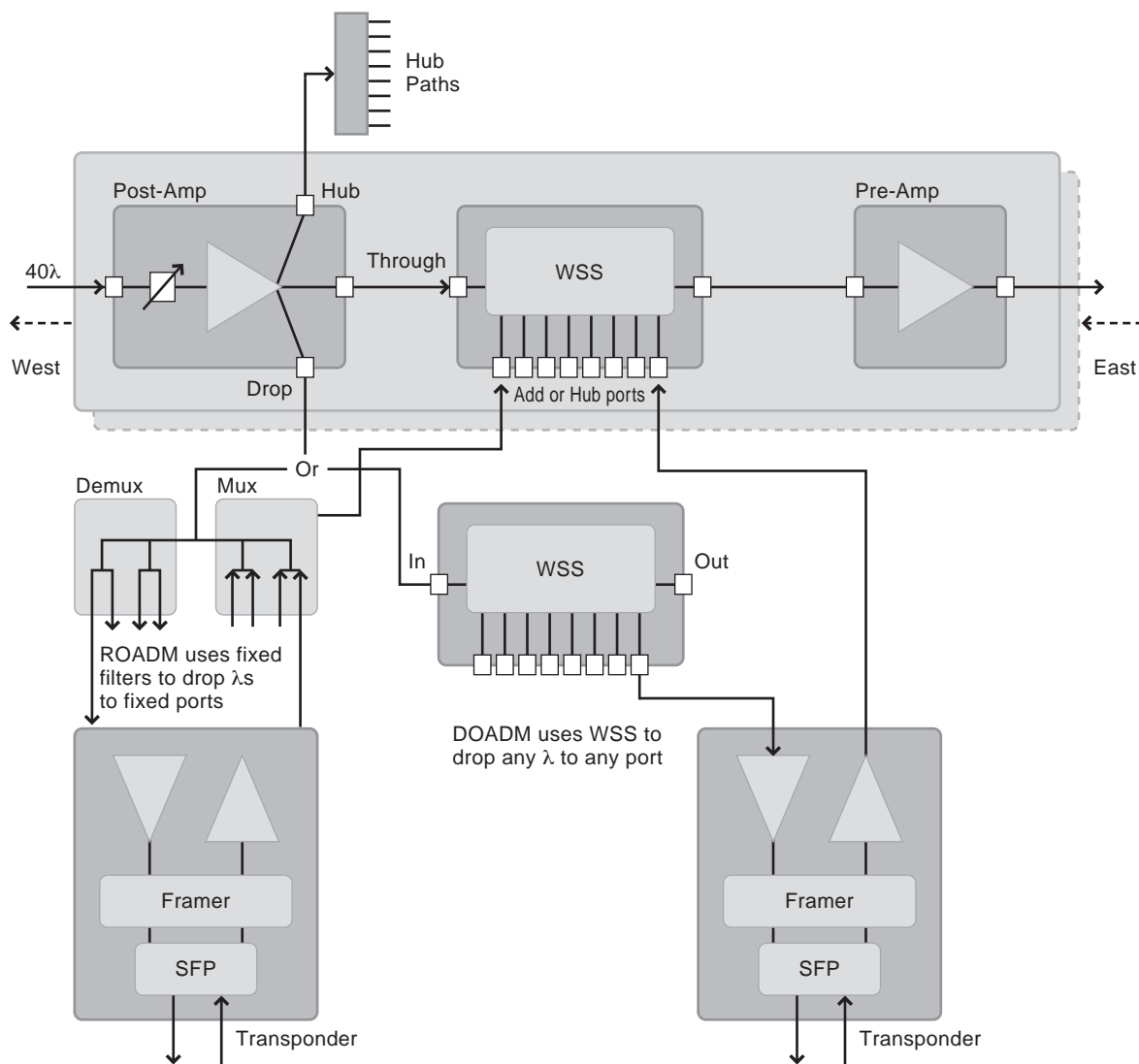

Figure 3  
FLASHWAVE architecture.

protected or un-protected traffic types.

A fiber coming into the system can carry up to 40 wavelengths. The signal is passed through a variable attenuator and then output to a post amplifier. The variable attenuator optimizes the signal level for best noise performance at the post amplifier and also normalizes power levels at each node around the ring, which simplifies span engineering. This process is fully automated by the system. The received signals are very weak and are amplified to bring them up to levels within the range acceptable for the optical receiver circuitry on the outgoing transponder cards. The

signal leaving the amplifier is split three ways to the drop, through, and hub ports. The operation of each of these ports is described below.

Drop traffic is demultiplexed using a WSS element or a low-cost arrayed waveguide (AWG). The optical receivers on the transponder cards are wideband and will therefore receive and recover any wavelength that is sent to them. Although an AWG costs less than a WSS element, the dropped wavelength depends on the output port that the transponder is connected to. On the other hand, a WSS element can drop wavelengths to any of multiple paths. If all the wavelengths can-

not be supported by a single WSS card, more WSS cards can be daisy chained to further separate the wavelengths until each one exits a single fiber. The advantage of using WSSs is that any wavelength can be directed to any output fiber. This mode of operation is called colorless because output ports are not associated with a particular wavelength or color. This means transponders can be pre-positioned in any slot and services can be provisioned to these transponders remotely and quickly. This added flexibility greatly improves traffic engineering and in-service provisioning times. Drop signals pass to the transponder cards that receive the optical signal, apply forward error correction, and recover the original electrical service. The transponders provide demultiplexing and protection switching functions before dropping client signals via low-cost SFP optical units.

Through traffic enters a WSS element, and wavelengths that were dropped and should not continue are blocked from the output fiber. The mirrors in a WSS position wavelengths passing through the node to the output fiber. Other wavelengths are added via transponder cards through add-port fibers on the WSS and are also directed to the output fiber. In this way, through traffic and add traffic are multiplexed together and then amplified and output from the node.

The hub port allows a new feature called hubbing. **Figure 4** shows the advantages of this hubbing feature. The system described so far has two degrees of freedom: a fiber pair sending traffic to the east and a fiber pair sending traffic to the west [Figure 4 (b)]. Hubbing allows additional optical core shelves and fiber pairs to be added. Traffic on any fiber pair can be sent to any other fiber pair. FLASHWAVE 7500 R4.1's architecture allows up to eight fiber pairs to be supported at a single node. Wavelengths can be changed from any fiber to any fiber. This feature permits new network configurations such as meshes to be supported and enables multiple rings to be constructed at a single site [Figure 4 (c) and

Figure 4 (d)].

#### 4. Future

The architecture of FLASHWAVE 7500 R4.1 is very forward looking. Current transponders in the system operate at a maximum of 10 Gb/s, but the system can grow to carry signals at 40 Gb/s. We are currently developing transponders that carry data at 40 Gb/s. These devices use a new optical modulation technique that keeps the spectral bandwidth narrow and close to that of a 10 Gb/s signal so 40 Gb/s signals can be carried over a network. A new component developed by Fujitsu called the automatic dispersion compensator<sup>(6),(7)</sup> will be used at each 40 Gb/s wavelength to tune out residual dispersion effects that remain from the bulk dispersion used for 10 Gb/s signals. This will allow 40 Gb/s signals to go almost as far as 10 Gb/s signals.

The architecture is ready for extension to long-haul applications. For example, another option will be a Raman amplifier that can be used in front of the system's EDFA amplifier at the end

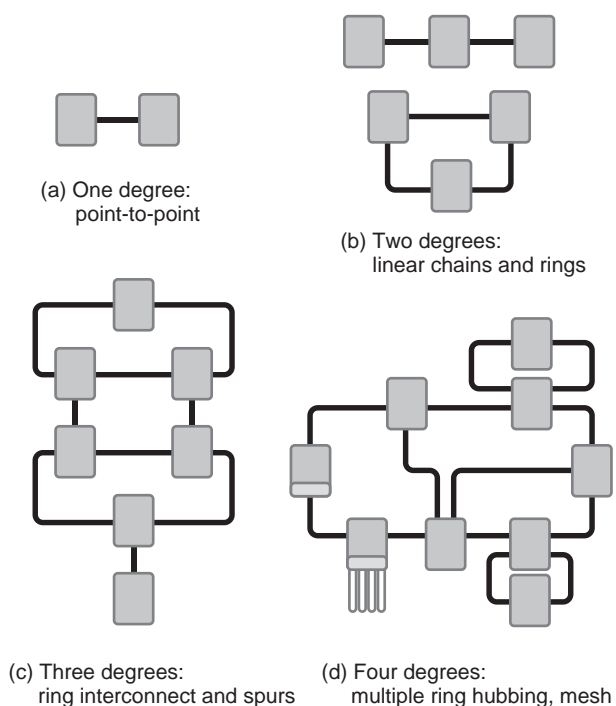

Figure 4  
Hub configurations.

of a span. This will extend span distances to meet regional networks, and more additions can make them even longer.<sup>8)</sup>

## 5. Conclusion

Optical technologies have been advancing for over 30 years. For most of this period, these technologies were used to enhance existing transmission equipment — firstly by increasing transmission distances and then by allowing more bandwidth on a fiber. Applications were primarily in long-haul environments. More recently, equipment has been designed using all-optical technologies for use in metro optical applications; however, because of operational difficulties and a lack of features, first-generation equipment saw only limited deployment and did not replace existing transmission technologies.

Optical technologies are advancing at a rapid pace, and Fujitsu is one of the first companies to use the latest superior technologies in new-generation optical transport products. The key technologies we are using are wavelength selectable switching, forward error correction, advanced amplifiers, full-band tunable lasers, and flexponders. By leveraging these technologies, we have created a new generation of ROADMs that features greatly improved specifications, enables new network configurations, and eases the operational problems of previous ROADMs. This new generation finally meets the many needs of oper-

ating companies and is expected to become the standard for data transmission in metro, IOF, and long-haul networks for all types of carriers.

FLASHWAVE 7500 R4.1 has been extensively tested by a major RBOC and has passed a large field trial. Fujitsu has engineered the product to be highly adaptable to new technologies; therefore, the platform should enjoy a long deployment life and readily evolve from a SONET/SDH-based circuit switched world to a packet-based world.

## References

- 1) C. R. Giles et al.: Propagation of Signal and Noise in Concatenated Erbium-Doped Fiber Optical Amplifiers. *IEEE Journal of Lightwave Technology*, **9**, 2, p.147-154 (1991).
- 2) W. J. Tomlinson et al.: Wavelength-selective switching — Architecture and Technology Overview. OFC 2004, WC3, 2004.
- 3) J. Buus et al.: Tunable Lasers in Optical Networks. *IEEE Journal of Lightwave Technology*, **24**, 1, p.5-11 (2006).
- 4) C. Tian et al.: Novel Solution for Transient Control of WDM Amplifiers Using the Combination of Electrical Feedforward and Feedback. CLEO 2004, CW02, 2004.
- 5) M. Tomizawa et al.: Forward Error Correcting Codes in Synchronous Fiber Optic Transmission System. *IEEE Journal of Lightwave Technology*, **15**, 1, p.43-52 (1997).
- 6) Y. Yamauchi et al.: Variable dispersion compensator using a VIPA with an extended bandwidth. ECOC 2005, **4**, 2005, p.821-822.
- 7) M. Shirasaki: Chromatic-Dispersion Compensator using Virtually Imaged Phased Array. OAA 1997, 1997, p.274-276.
- 8) — : Heavy Reading report: ROADMs and the Future of Metro Optical Networks. **3**, 8, May 2005.



**Hiroyuki Matsumoto, Fujitsu Ltd.**

Mr. Matsumoto received the B.S. degree in Electronics Engineering from Shibaura Institute of Technology, Tokyo, Japan in 1979. He joined Fujitsu Ltd, Kawasaki, Japan in 1982, where he has been engaged in product development of access and WDM systems for overseas telecommunication markets.

E-mail: matsuumoto.hi-09@jp.fujitsu.com



**Hatsumi Iino, Fujitsu Ltd.**

Ms. Iino received the B.S. degree in Science from Science University of Tokyo, Japan in 1986. She joined Fujitsu Ltd., Kawasaki, Japan in 1986, where she has been engaged in system engineering of telecommunication products for the US market. From 1995 to 2003, she was assigned to Product Planning & Management, Fujitsu Network Communications in Texas, US.

E-mail: iino.hatsumi@jp.fujitsu.com



**Stephen Carlton, Fujitsu Network Communications Inc.**

Mr. Carlton received the B.S. degree in Electronics Engineering from Leicester Polytechnic, UK, in 1978. He worked for 16 years as a system architect and developer of optical transmission systems with Bell Northern Research and Alcatel. He has 7 patents related to this work. He joined Fujitsu Network Communications in 1998, where he has

since been engaged in planning and product management of WDM and SONET products.

E-mail: stephen.carlton@us.fujitsu.com