

Mobile HDDs

● Shigenori Yanagi

(Manuscript received July 19, 2005)

Fujitsu has developed 120 GB and 160 GB capacity HDDs for notebook PCs and other mobile applications. The high capacities of these drives open up new market opportunities such as mobile audio-video applications. This paper introduces Fujitsu's MHV series of mobile HDDs, which are our latest 2.5-inch models. The MHV series feature an areal density of 99.1 Gbit/in², which is the world's highest for a 2.5-inch drive. Also, they have a 150 MB/s transfer speed serial-ATA (SATA) interface with Native Command Queuing (NCQ), are very rugged and quiet, and are very popular with our customers. This paper introduces the head, medium, mechanical, and electronic technologies of the MHV series.

1. Introduction

In 2001, Fujitsu released the MHR (Hornet-15L) series,¹⁾ and we were regarded as a supplier of very high quality and very reliable HDDs. In 2003, the 2.5-inch HDD industry was struggling due to the low productivity of 2.5-inch 40 GB/platter HDDs, and only Fujitsu's MHT series maintained a high level of productivity and won a large share of the 2.5-inch HDD market. The MHT series were also very well known for their excellent quality, reliability, performance, and quietness. As a result, Fujitsu's 2.5-inch HDD market share increased from 11.89% in 2002 to 22.43% in 2004.²⁾

The newest MHV series of Fujitsu Mobile HDDs (**Figure 1**) have been introduced between the end of 2004 and 2005, and we hope they will be even more successful than the MHT series. The growth rate for laptop PCs is one of the highest in the IT industry, and the MHV series are the main storage devices for laptop PCs. In this paper, We discuss the trends, technologies, and design features of mobile HDDs.

2. Market trends in 2.5-inch ATA HDDs

In 2004, 158 million 3.5-inch ATA HDDs were installed in desktop PCs,²⁾ and the growth rate of this market was 7.6%.²⁾ The total production volume in this year for 2.5-inch ATA HDDs was 56 million,²⁾ — this represents a growth rate of 19.5%,²⁾ which was very strong compared to the growth rate for 3.5-inch ATA HDDs for desktop PCs. On the other hand, 3.5-inch ATA HDDs for the CE market (i.e., for HDD recorders) is now growing rapidly. The growth rate of 3.5-inch HDDs for the consumer electronics (CE) market was 40% in 2004^{note)} and is expected to increase to 52% in 2005.^{note)} Because of the expansion of the HDD recorder market and the diversity of customers' needs, not only products with 3.5-inch HDDs of several hundred gigabytes, but also smaller, quieter, and lower power consumption HDD recorder products will become very popular.

We predict that the quantity to CE market for 2.5-inch HDDs will increase soon (**Figure 2**).

note) Fujitsu HDD Market Size Estimation, 2005.



Figure 1
MHV2120BH.

3. Requirement for 2.5-inch HDDs

This section describes the market and customer requirements for 2.5-inch HDDs.

3.1 TTM and TTV

Time To Market (TTM) and Time To Volume (TTV) are the most fundamental requirements in the HDD industry. These goals are very simple for standardized products such as HDDs, but they are more difficult for high-technology products. High capacity and low price appear to be conflicting goals, but a higher areal density increases capacity and simultaneously reduces the number of heads and media platters and therefore reduces the price. HDD manufacturers need to pay careful attention to their procurement process, production yield, and supply chain management (SCM) and also need to secure a stable source of components.

3.2 RoHS compliance

The European Union's directive on the restriction of the use of certain hazardous substances in electrical and electronic equipment (RoHS) will come into effect on July 1, 2006 and

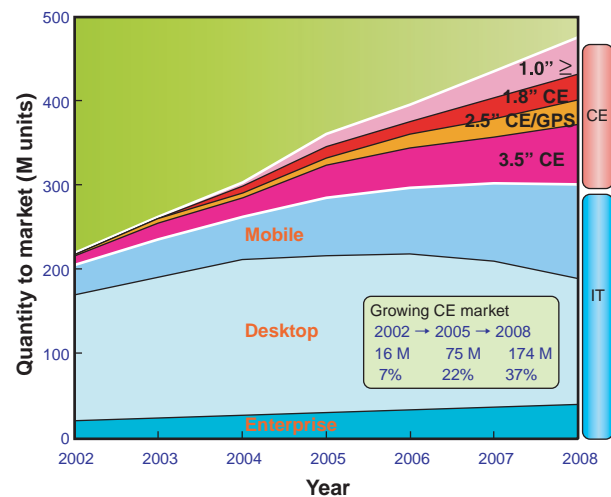

Source: Fujitsu November 2005.

Figure 2
HDD markets for each platform.

will prohibit the presence of harmful materials such as lead, mercury, and cadmium in HDDs.

3.3 Quality and reliability

The HDD in a laptop PC or other system represents only a small part of the system's cost; but when an HDD fails, the repair fee is much higher than the cost of the HDD. Therefore, the quality and reliability of HDDs must be very high.

3.4 Shock and vibration resistance

HDDs are very sensitive to shock and vibration because of the extremely narrow space between the head and media and the extremely narrow recording tracks. Nevertheless, HDDs for mobile applications must be highly resistant to shock and vibration.

3.5 Performance

The Bench Mark test score, which indicates an HDD's read/write performance, is expected to improve with each new product generation. Customers can use this benchmark to compare the performance of various HDDs, which stimulates manufacturers to make their products more competitive.

3.6 Power consumption

HDDs are often installed in mobile equipment powered by batteries, and these HDDs must have a low power consumption to extend the battery life.

3.7 Acoustics

Because laptop PC operators are physically close to their PCs, they can hear the noise the HDDs produce. Therefore, the noise level of laptop HDDs must be reduced, and the type of sound they produce must be altered so it becomes less irritating.

4. Features of MHV series

Table 1 shows the lineup of the MHV series.

4.1 Large capacity

The platters of the MHV series have a maximum capacity of 60 GB. The drive capacities range from 40 to 120 GB for the 95 mm-height drives, and the capacity of the 12.5 mm-height drive is as high as 160 GB, which is currently the

world's highest capacity 2.5-inch HDD. These capacities are available not only for laptop PCs, but also for digital video recording equipment.

4.2 Lead free

To comply with the RoHS directive, the MHV series do not contain lead, cadmium, mercury, or any of the other hazardous materials prohibited by the directive.

4.3 Durability

A new strong, lightweight suspension ensures very stable head flight and improves the shock durability, which greatly improves the reliability of the MHV series.

4.4 Performance

A new cache algorithm improves the read/write performance under most operational conditions. The serial-ATA (SATA) model achieves a dramatic improvement in performance by using Native Command Queuing (NCQ) during random reading.

Table 1
Lineup of MHV series.

	MHV2xxxAH	MHV2xxxAT	MHV2xxxBH	MHV2160BT
Capacity (GB)	40/60/80/100/120	40/60/80/100/120	40/60/80/100/120	160
Dimensions: W × D × H (mm)	70 × 100 × 9.5	70 × 100 × 9.5	70 × 100 × 9.5	70 × 100 × 12.5
Weight (g)	101	100	101	135
Rotational speed (rpm)	5400	4200	5400	4200
Average seek time (ms)	12	12	12	12
Transfer rate (MB/s)	100	100	150	150
Interface	ATA	ATA	SATA	SATA
Start time (s)	4.0	3.5	4.0	3.5
Power	Read/write (W)	1.9	1.6	1.9
	Idle (W)	0.6	0.5	0.6
	Standby (W)	0.2	0.2	0.13
	Sleep (W)	0.1	0.1	0.13
Shock	Operating (m/s ²)	2940	2940	2940
	Non-operating (m/s ²)	8820	8820	8820
Vibration	Operating (m/s ²)	9.8	9.8	9.8
	Non-operating (m/s ²)	49	49	49
Sound	Idle (Bel)	2.6	2.4	2.6
	Seek (Bel)	2.8	2.8	2.8

4.5 Power consumption

The greatest merit of the MHV series is their low power consumption, which is the lowest among 2.5-inch HDDs. Especially, the SATA model consumes the same power as a Parallel ATA (PATA) HDD.

Figure 3 compares the power consumptions of the MHT-SATA, MHV-SATA, and MHV-PATA HDDs.

4.6 Acoustics

Fujitsu's 2.5-inch HDDs are well known for their quietness, and the MHV series are even quieter thanks to mechanical and electrical improvements that have been made to the spindle motor and drive circuit. In fact, it is fairly difficult to hear the MHV series operating.

5. Technologies

This section introduces the design details of the MHV series.

5.1 Mechanism

Figure 4 shows the mechanism of the MHV2160BT.

The spindle motor rotates three magnetic media platters counter clockwise, and the read/write heads fly above the media due to the aero-

dynamics between the heads and media surfaces. The heads are mounted on a rotational actuator with a powerful voice coil motor, which quickly positions the heads at the required data tracks.

The heads fly above the media during operation. If a sufficiently large shock is applied to the HDDs, the heads will hit the media surfaces and damage the media's recording layers, which may result in corrupted data. The lift-off acceleration of the heads and suspension from the media surfaces during a shock is the force applied to those components divided by their mass. Therefore, the shock resistance is inversely proportional to the mass of the heads and suspension. **Figures 5 and 6** show the suspensions of the MHV series and MHT series, respectively.

The new suspension is 50% lighter than the previous suspension, which makes the MHV series very durable.

During idling and power-off, the HDDs are highly shock resistant because the heads are parked in the retracted position on the ramp (Figure 4).

The only moving components inside the HDDs are the spindle motor and the voice coil motor. Both these components are carefully designed for high reliability. To achieve good acoustics and durability, the mechanical base must

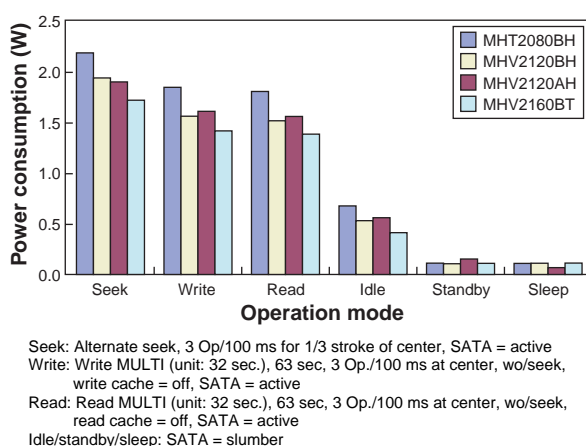

Figure 3
Comparison of power consumption.

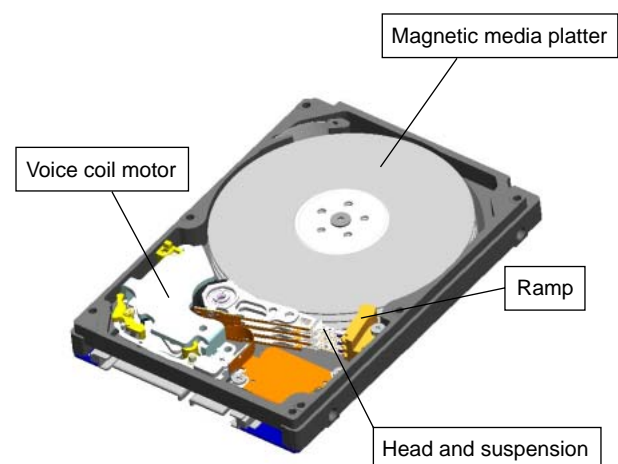

Figure 4
MHV2160BT mechanism.



Figure 5
New suspension (MHV series).



Figure 6
Previous suspension (MHT series).

be very rigid, and the bases of the MHV series are more rigid than those of the previous generation.

5.2 Heads

The heads are the transducers that convert magnetic information to electrical signals and are the key components for realizing higher areal densities and a huge storage capacity. The areal density is increased by decreasing the size of the magnetic domains, which reduces the strength of the output signal. The head design of the MHV series significantly improves the efficiency of magnetic-to-electrical conversion, leading to a 60 GB/platter capacity.

5.3 Media

Thermal decay is an important design point for longitudinal recording media. The magnetic coercivity and thickness of the magnetic recording layer are important parameters for controlling thermal decay. The MHV series achieve semi-permanent (over 5 years) data recording by using a thick recording layer made of a high-coercivity material.

5.4 Circuit

Figure 7 shows the MHV series circuit diagram.

This circuit has basically been the same for two years, and there are no major changes. However, it has been improved to increase the transfer speed and reduce the power consumption. For

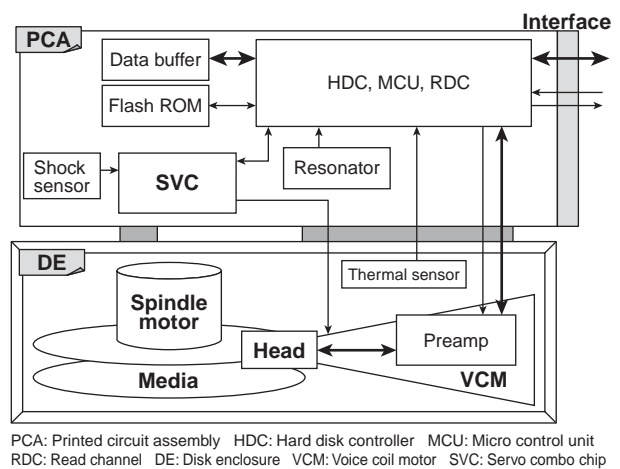

Figure 7
MHV series circuit diagram.

example, the MHV series have a new Servo Combo Chip (SVC) that reduces the spindle motor's electromagnetic noise and increases its efficiency.

5.5 Serial ATA

The MHV series use two families of host interfaces. One is the conventional PATA interface with transfer speeds up to 100 MB/s, and the other is the brand new, sophisticated 150 MB/s SATA interface. Fujitsu released the MHT-BH series of HDDs as the world's first 2.5-inch HDDs with the new SATA interface in the beginning of 2004. The MHV are Fujitsu's second series of SATA HDDs and incorporate some improvements over the MHT-BH series. They use a hardware accelerator to improve the overall performance of

NCQ and support all the LPMs prescribed in the SATA specification. Moreover, they achieve an even lower power consumption by using the hardware support function to control the power mode transitions of interfaces. In fact, the MHV SATA has the same power consumption as a PATA HDD, which makes it the lowest power consumer among current SATA HDDs.

6. Conclusion

Customers require low-price mobile HDDs that provide a high level of quality, reliability, and performance, and HDD vendors are working hard to meet these requirements. Recently, the rate of increase in areal density has slowed down, which is why growth in the HDD industry is stable. However, the structure of the HDD industry will undergo a dramatic change when HDD vendors switch to perpendicular recording. A downsizing

trend from 3.5-inch to 2.5-inch is expected, and some of the 2.5-inch market will shift to the smaller 1.8-inch form-factor, which will steadily become popular among customers. This downsizing will be a very important process for both HDD vendors and customers and will create a new market not only in the IT industry but also in the CE market. To achieve this downsizing, Fujitsu will closely collaborate with its customers. Fujitsu is not only developing leading-edge technologies, but is also striving to produce the products that customers require. We sincerely believe that Fujitsu is contributing to the betterment of society through HDD development.

References

- 1) A. Makita: 2.5-inch Hard Disk Drives for Mobile Applications: Hornet-15L. *FUJITSU Sci. Tech. J.*, **37**, 2, p.140-144 (2001).
- 2) Gartner/Dataquest: Gartner Dataquest Market Statistic 2005. March 2005.



Shigenori Yanagi received the B.S. degree in Applied Physics from Waseda University, Tokyo, Japan in 1985. He joined Fujitsu Ltd., Kawasaki, Japan in 1985, where he has been engaged in development of optical disk drives for 16 years. Since 2001, he has also been engaged in development of mobile hard disk drives.

E-mail: yanagi@jp.fujitsu.com