

Simple Micro-Lens with Polymer-Filled Trench in Slab Waveguide

●Koji Tsukamoto ●Akio Sugama ●Yukiko Wakino
●Tomoko Miyashita ●Masayuki Kato

(Manuscript received March 15, 2002)

We have developed a new micro-lens array that is integrated into silica slab waveguides. This paper reports the design, material, fabrication, and performance of this new array. The micro-lens has a concave trench filled with a low refractive index polymer. The array has a low insertion loss (0.5 dB), low crosstalk (< -40 dB), and stable characteristics. Our experiments indicate that the micro-lens is suitable for use in two-dimensional optical switches of advanced photonic networks.

1. Introduction

Optical waveguide circuits enable the construction of compact and highly reliable photonic devices. They are more resistant to vibration and temperature change than optical modules assembled with bulky optical components. Many kinds of optical waveguide circuits have been investigated for applications in optical fiber communication systems.¹⁾⁻⁷⁾ Especially, slab waveguides combined with micro-lenses and/or active deflectors are promising for optical path crossings, two-dimensional imaging optics, and optical scanning systems. Some example applications of these devices are in spectrum analyzers⁸⁾⁻¹⁰⁾ and optical switches.¹¹⁾⁻¹²⁾

We propose a two-dimensional optical switch consisting of silica slab waveguides, electro-optic (EO) deflectors, micro-lenses, and channel waveguides. **Figure 1** shows schematic top-views of the optical switch and the unit structure without the EO deflectors. This optical switch has the advantage of providing a uniform insertion loss in all the optical paths, easy expansion of channel numbers without a corresponding increase in device size, and high-speed switching

because of the use of EO deflectors.

We have demonstrated a new micro-lens for collimating and focusing light beams, which are essential functions in our optical switch. The design, fabrication process, and performance of this device are described below.

2. New micro-lens structure

We are developing our two-dimensional optical switch for advanced photonic network systems. Therefore, the micro-lenses in the optical switch must be transparent at the wavelength of 1550 nm. **Table 1** shows the requirements for the micro-lens. To keep the overall insertion loss of our optical switch within the target 10 dB maximum, the insertion loss of the micro-lens must be 0.5 dB or less. Also, to keep the power penalty within acceptable limits, the crosstalk between channels should be less than -40 dB.

The key task in the development of the new micro-lens was to design a simple structure that is suitable for mass-production. **Figure 2** shows the conventional micro-lenses that have been reported so far, all of which are aberration free.

1) Geodesic lenses¹³⁾ have a three-dimensional

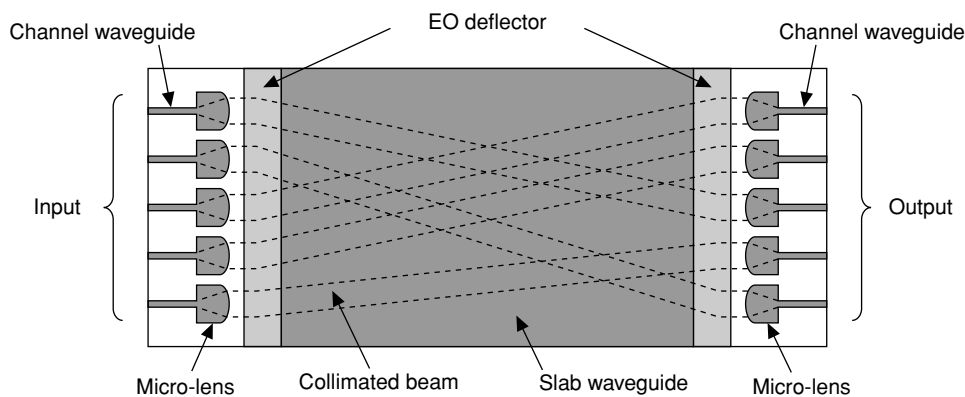

(a) Two-dimensional optical switch

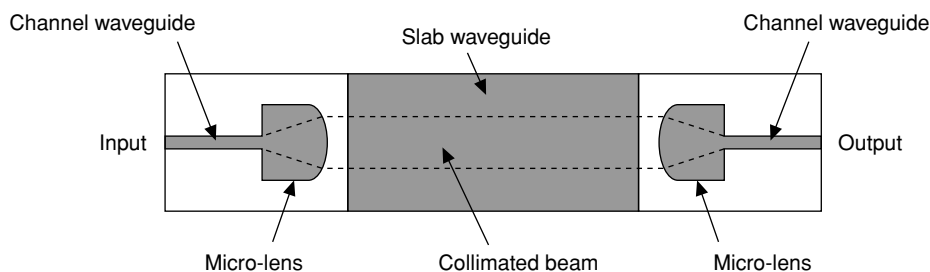

(b) Basic structure

Figure 1
Micro-lens integrated in slab waveguides.

Table 1
Requirements for micro-lens.

Wavelength	1550 nm
Propagation mode	Single
Insertion loss	≤ 0.5 dB
Crosstalk	< -40 dB

curved surface. It is difficult to fabricate this surface with high precision; so geodesic lenses are not suitable for mass-production.

- 2) Diffraction lenses¹⁴⁾ or Fresnel lenses¹⁵⁾ have the problems of strong wavelength dispersion, zero-order transmission, and higher order diffraction. It is difficult to keep the crosstalk of these lenses below -30 dB, so they are also not suitable for our optical switch.
- 3) Mode-index lenses distribute the effective

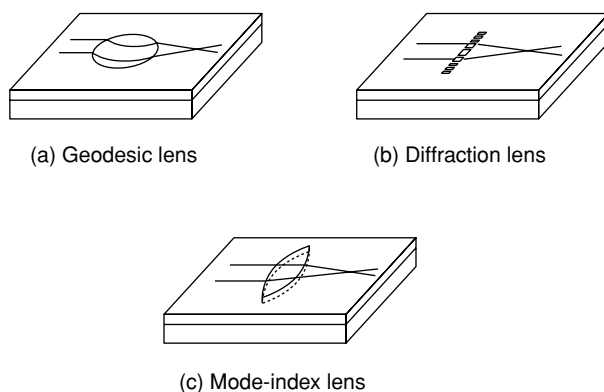

Figure 2
Conventional micro-lenses for waveguides.

refractive index in the waveguide core. It has been suggested that structures having a continuous variation in effective refractive index can be achieved by introducing a graded thickness change or diffusing chemical ele-

ments into the waveguide.¹⁶⁾ However, this structure makes it difficult to achieve a precise refractive index distribution. Therefore, conventional mode-index lenses are also unsuitable for mass-production.

Figure 3 shows a new micro-lens we have developed. It is a type of mode-index lens, but the structure is suitable for mass-production because the trench is formed using the same dry-etching process as the one used in core

patterning and then the trench is simply filled in with a polymer. The sidewalls of the concave trench form a convex lens, because the refractive index of the polymer added to the trench is less than that of the silica waveguide material. Compared to other convex structures, this structure allows the distance between the lens sidewalls across the trench to be made much shorter. Because of the shorter distance, the divergence loss, which is the dominant part of the insertion loss of mode-index lenses, is reduced. Therefore, our new micro-lens provides a low insertion loss and is also suitable for mass-production.

In the next section, we describe the design of two types of micro-lens arrays we have made using this structure.

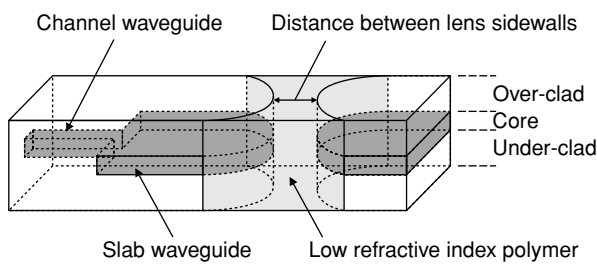

Figure 3
New micro-lens with concave trench.

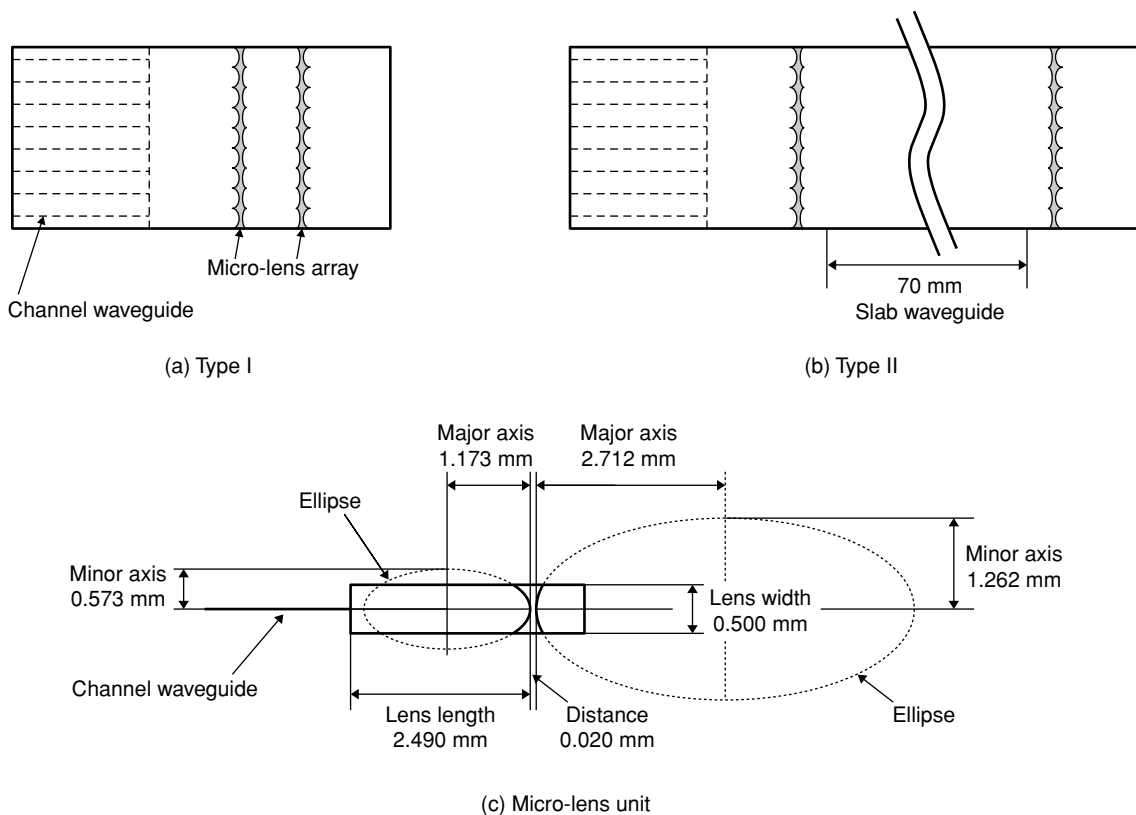

Figure 4
Type I and Type II micro-lens arrays.

3. Design details

3.1 Micro-lens

Figure 4 shows two micro-lens arrays we have designed and fabricated. The Type I array has input channel waveguides, collimating micro-lenses, a short slab waveguide, and focusing micro-lenses. The Type II array is basically the same as the Type I except it has a longer (70 mm) slab waveguide. These arrays were made without output channel waveguides so we could directly observe the beam spots at the foci of the micro-lenses and estimate the crosstalk at the output surface.

1) Waveguide parameters

The parameters of the channel waveguides and slab waveguide were selected for single-mode propagation at 1550 nm. The relative difference in the refractive indexes of the waveguide core and the clad is 0.4%. The thicknesses of the core and over-clad are 3 μm and 8 μm , respectively. The core width is 5 μm , and the under-clad is a 1 mm-thick silica substrate.

2) Focal length and lens width

Using the BPM_CAD beam propagation method software, we set the focal length of the micro-lens so that the beam width was narrower than 210 μm . **Figure 5** shows the results of simulating the relationship between the focal length and beam width. The focal length was

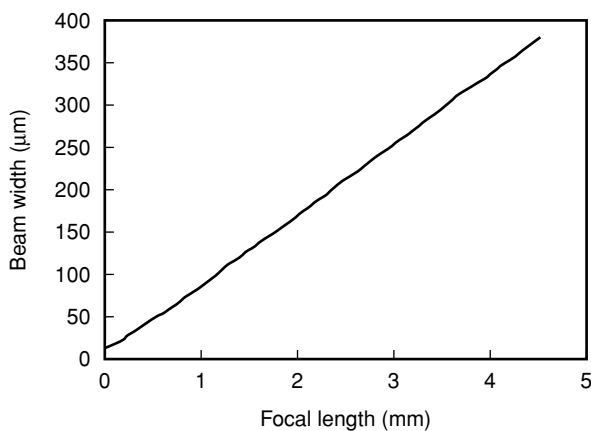

Figure 5
Relationship between focal length and beam width (simulated).

determined to be 2.5 mm. To reduce scattering at the side edges of the micro-lens, the width of the micro-lens is 500 μm , which is more than twice the 210 μm beam width.

3) Trench depth and distance between micro-lens sidewalls

The trench was made 20 μm deep so that the beam spot does not extend to the bottom of the trench. **Figure 6** shows the results of simulating the light intensity profile in the silica slab waveguide. The bottom edge of the beam spot is less than 20 μm from the top surface of the over-clad. The distance between the micro-lens sidewalls was designed to be 20 μm . The narrowest trench has an aspect ratio of 1 and is easy to fabricate by dry etching. **Figure 7** shows the results of simulating the divergence loss of light passing through the trench. When the distance between the micro-lens sidewalls was set to 20 μm , the simulation indicated a divergence loss of 0.36 dB.

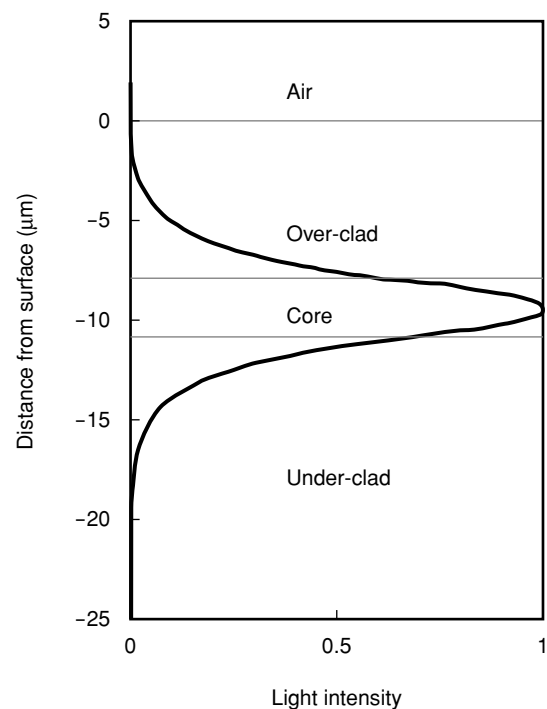

Figure 6
Light intensity profile (simulated).

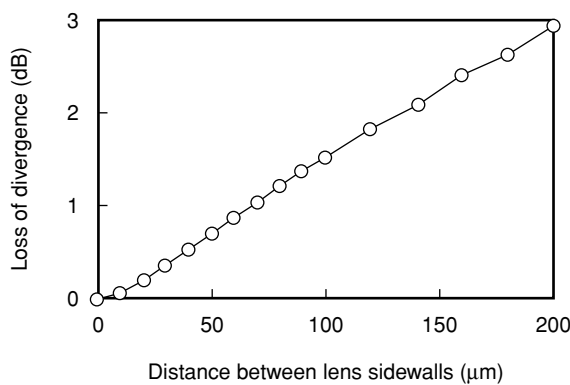

Figure 7
Loss of divergence (simulated).

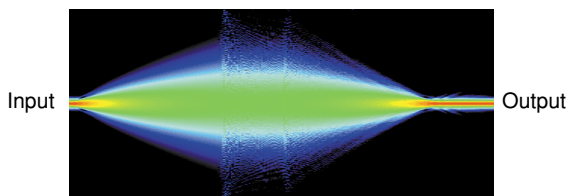

Figure 8
Beam propagation in Type I array (simulated).

4) Curvature of the micro-lens

The curvature of the micro-lens is elliptic. We used the CODE V lens design software and BPM simulation to optimize the major and minor axes so that the coupling loss due to aberration was minimized. The optimized values are shown in Figure 4 (c). **Figure 8** shows an example simulation of beam propagation in the Type I array with output waveguides.

5) Insertion loss

The insertion loss of the micro-lens was estimated by taking account of the reflection loss at the lens sidewalls and the divergence loss in the polymer-filled trench. The estimation is shown in **Table 2**. The total loss is estimated to be 0.40 dB, which is within the target value of 0.5 dB.

6) Crosstalk

We estimated the crosstalk in the micro-lens arrays by taking account of light divergence from neighboring channels. At an array pitch of 500 μm, the calculated crosstalk is less than -47 dB, which meets the target of less than -40 dB. The micro-

Table 2
Estimated loss of micro-lens.

	(Unit: dB)
Aberration	0.02
Reflection	0.01
Divergence	0.36
Silica waveguide part (2.5 mm)	0.01
Polymer (20 to 100 μm)	<< 0.01
Total	0.40

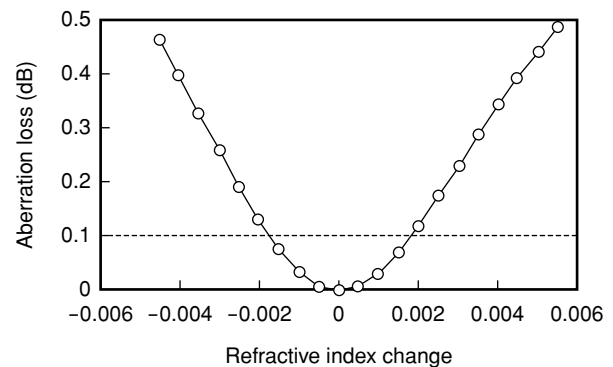

Figure 9
Increase in aberration loss vs. change in refractive index of polymer (simulated).

lens pitch was designed to be 500 μm.

3.2 Trench polymer

To ensure the long-term stability of the micro-lens, the polymer used to fill in the trench must have the following characteristics:

- 1) It must be transparent at 1550 nm, and its refractive index must be smaller than that of the silica waveguide (1.445).
- 2) It must be suitable for application as a liquid and then become solid after curing.
- 3) It must be stable over a wide range of temperature and humidity.

Figure 9 shows the results of simulating the increase in aberration loss that occurs when the refractive index changes. According to the simulation, to keep the increase in aberration loss below 0.1 dB, the refractive index must stay within ±0.0017.

Table 3 shows the characteristics of various kinds of polymers. Non-fluorinated polymers,

Table 3
Characteristics of polymers.

		Refractive index (n_D) ^(note 2)	Transmittance (%) ^(note 3)	Glass transition temperature (°C)	Water absorption (wt%)	Elongation (%)	Filling
Fluorinated polymers	Amorphous perfluoropolymer ^(note 1)	1.34	95	108	< 0.01	150	Possible
	Polytetrafluoroethylene	1.34	Opaque	130	< 0.01	300	Not Possible
	Poly (tetrafluoroethylene-co-perfluoroalkylvinylether)	1.35	Opaque	75	< 0.01	300	Not Possible
Non-fluorinated polymers	Polymethylmethacrylate	1.49	92	90	3.0	10	Possible
	Polycarbonate	1.58	90	140	0.5	100	Possible
	Polystyrene	1.59	90	90	0.2	2	Possible
	CR-39	1.50	91	90	0.7	2	Possible

note 1) Cytop (Asahi Glass Company)

note 2) Wavelength: 589.3 nm

note 3) Visible region

Table 4
Reliability test conditions for filling polymer.

Test	Conditions
Damp heat	85°C/85%RH, 500 h
High-temperature storage	85°C, 2000 h
Low-temperature storage	-40°C, 2000 h
Temperature cycling	-40 to + 85°C, 500 cycles

which are commonly used in optical devices, have higher refractive indices than silica and are therefore not suitable for our micro-lens. On the other hand, some fluorinated polymers have a lower refractive index than silica. Among the fluorinated polymers, amorphous perfluoropolymer⁽¹⁷⁾ is the only candidate because it is the only one that is transparent in the visible region and can enter a trench that is only 20 μm wide.

We examined the film characteristics of amorphous perfluoropolymer with spin-coated samples on silicon substrates. Reliability tests (damp heat and temperature cycling) were performed under the conditions shown in **Table 4**. The refractive index and transparency were stable within 1.334 ± 0.001 and $95 \pm 1\%$, respectively, under all the test conditions. This small change of refractive index means that the increase in insertion loss can be kept below 0.1 dB (Figure 9). Neither voids nor cracks were observed during the tests. We think this high quality is due to proper-

ties of amorphous perfluoropolymer such as its relatively high glass transition temperature and low water absorption under the conditions shown in Table 4. The reliability tests showed that amorphous perfluoropolymer is stable for use in our micro-lens.

4. Fabrication

Figure 10 shows the fabrication process for the micro-lens and channel waveguide.

- 1) A 3 μm -thick core layer is deposited on a 6-inch silica wafer by chemical vapor deposition (CVD).
- 2) A metal mask for a channel waveguide is formed, and the core pattern is transferred by reactive ion etching (RIE).
- 3) An 8 μm -thick over-clad layer is deposited by CVD.
- 4) A metal mask for the micro-lens is formed, and the trench is made by RIE.
- 5) The trench is filled with the polymer, which is then cured at 180°C for one hour.

Figure 11 shows photographs of the fabricated micro-lenses. The difference in the designed lens curve and the measured lens curve was less than 2 μm . The sidewalls of the trench are almost vertical, with deviations of only 2° and 5°. As shown in **Table 5**, a calculation of the insertion loss with these fabrication errors included is estimated to be 0.5 dB, which meets the target value of 0.5 dB or less.

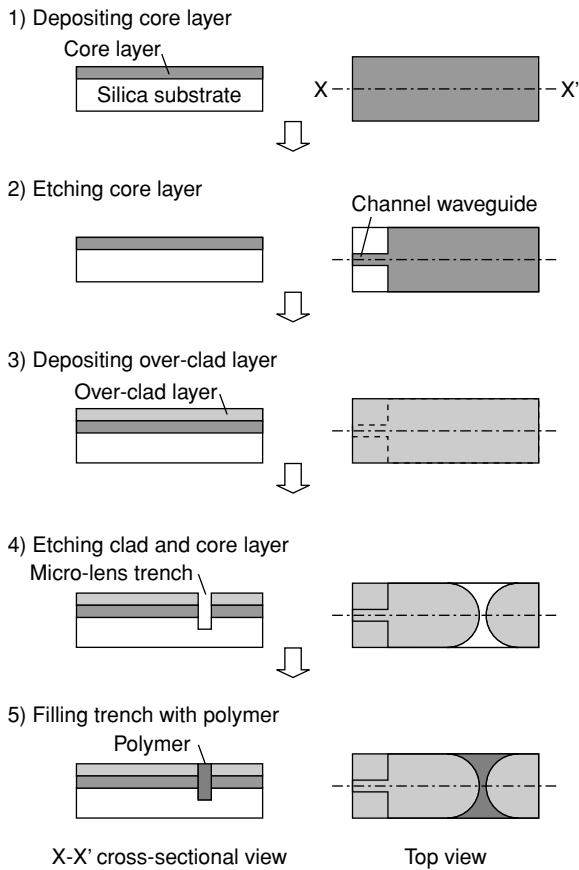

Figure 10
Fabrication process.

5. Performance

We measured the optical characteristics of the micro-lens at 1550 nm by coupling an input channel waveguide to a single-mode optical fiber. The results are summarized in **Table 6**.

1) Spot size

Near-field patterns were observed at the output side of the Type I array. The spot size was measured with a laser beam profiler (LEPAS-11: Hamamatsu Photonics). The light intensity profile was Gaussian-like and was considered to be single mode. The spot size (FWHM) was 10 μm in the x direction (parallel to the substrate) and 9 μm in the y direction (perpendicular to the substrate), which is very close to that of a single mode fiber.

2) Insertion loss

To estimate the insertion loss of the micro-

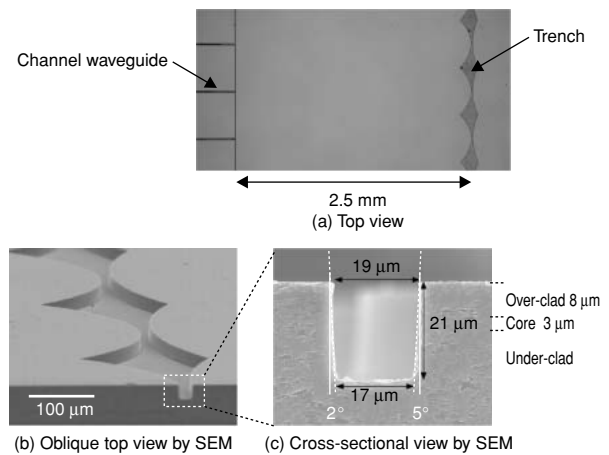

Figure 11
Photographs of fabricated micro-lens.

Table 5
Modified loss estimation including fabrication error.

(Unit: dB)	
Estimated loss (Table 2)	0.40
Lens curvature error	0.04
Slope of sidewall	0.06
Total	0.50

Table 6
Measured optical characteristics of micro-lens.

Beam profile (Spot size)	Near-field pattern 9 μm 10 μm (FWHM)
Insertion loss	0.51 dB (average)
Crosstalk	< -56 dB

lens, we first measured the total loss across the Type I array and then subtracted the fiber coupling loss and the 0.050 dB/cm channel waveguide loss that we measured in another test sample. The results indicated that the average insertion loss of the micro-lens was 0.51 dB (0.42 dB minimum, 0.63 dB maximum), which is close to the estimated value of 0.50 dB and the target value.

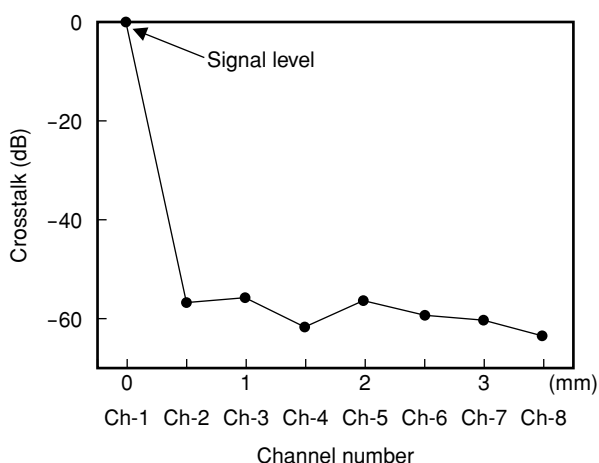

Figure 12 Inter-channel crosstalk in Type II micro-lens array (measured).

3) Crosstalk

We defined the crosstalk of the micro-lens arrays as the ratio of divergence power coupled to an optical fiber positioned at the output focal point of a neighboring channel (Ch-2 to Ch-8) to the signal power input to the channel waveguide (Ch-1). As shown in **Figure 12**, the measured crosstalk in each channel of the Type II array was less than -56 dB. The total amount of crosstalk among several tens of channels is thought to be less than -40 dB, which is within the target value. The measured value is slightly less than the calculated one, and the difference is thought to be due to two reasons. The first is that the focal length of the fabricated micro-lenses was measured to be $73\ \mu\text{m}$ shorter than the design value. The second is that the channel waveguide cores seem to be wider than the designed value of $5\ \mu\text{m}$. We are currently investigating ways to exercise precise control of these dimensions.

4) Temperature cycle tests

We subjected the Type I array to 500 temperature cycles from -40 to 85°C and measured its insertion loss and return loss at various points in the procedure. **Figure 13** shows the results. The return loss stayed constant around 47 dB, even after 500 cycles. The return loss of

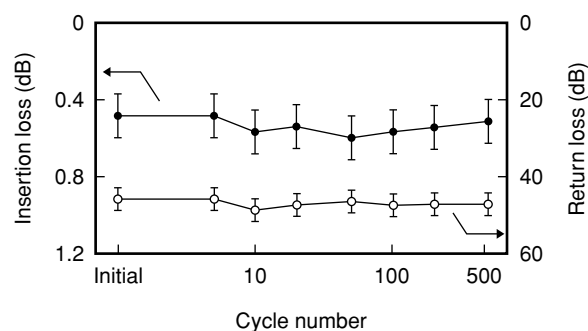

Figure 13 Insertion and return losses of Type I array in temperature cycle test.

the micro-lens without the polymer in the trenches was measured to be 27 dB. If there was any peeling at the silica-polymer interface, the return loss would have changed to about 27 dB, but the experimental results showed there was no such change and therefore we concluded there was no peeling. Also, there was no observable change in insertion loss after the 500 cycles. These results show that the micro-lenses are reliable and suitable for use in optical switches.

6. Conclusion

We have developed a new micro-lens array integrated in a silica slab waveguide. The micro-lens was fabricated by precise trench etching and filling with amorphous perfluoropolymer. We have demonstrated that the new device has a low insertion loss of 0.5 dB, a low crosstalk of less than -56 dB, and stable characteristics during temperature cycle testing. Experiments have shown that the new micro-lens is suitable for use in two-dimensional optical switches and integrated silica waveguide devices.

References

- 1) S. Kobayashi, T. Kitoh, Y. Hida, S. Suzuki, and M. Yamaguchi: Y branching silica waveguide 1×8 splitter module. *Electron. Lett.*, **26**, 11, p.707-708 (1990).
- 2) K. Jinguji, N. Takato, A. Sugita, and M. Kawachi: Mach-Zehnder interferometer type

- optical waveguide coupler with wavelength-flattened coupling ratio. *Electron. Lett.*, **26**, 17, p.1326-1327 (1990).
- 3) K. Okamoto, H. Okazaki, Y. Ohmori, and K. Kato: Fabrication of large scale integrated-optic $n \times n$ star couplers. *IEEE Photon. Tech. Lett.*, **4**, 9, p.1032-1035 (1992).
 - 4) H. Okayama and M. Kawahara: Prototype 32×32 optical switch matrix. *Electron. Lett.*, **30**, 14, p.1128-1129 (1994).
 - 5) T. Goh, M. Yasu, K. Hattori, A. Himeno, M. Okuno, and Y. Ohmori: Low-loss and high-extinction-ratio silica-based strictly nonblocking 16×16 thermo-optic matrix switch. *IEEE Photon. Tech. Lett.*, **10**, 6, p.810-812 (1998).
 - 6) H. Takahashi, S. Suzuki, and I. Nishi: Wavelength multiplexer based on $\text{SiO}_2\text{-Ta}_2\text{O}_5$ arrayed-waveguide grating. *J. Lightwave Tech.*, **12**, 6, p.989-995 (1994).
 - 7) Y. Inoue, A. Kaneko, F. Hanawa, H. Takahashi, K. Hattori, and S. Sumida: Athermal silica-based arrayed-waveguide grating multiplexer. *Electron. Lett.*, **33**, 23, p.1945-1946 (1997).
 - 8) D. B. Anderson, J. T. Boyd, M. C. Hamilton, and R. R. August: An integrated-optical approach to the Fourier transform. *IEEE J. Quantum Electron.*, **QE-13**, 4, p.268-275 (1977).
 - 9) D. Mergerian, E. C. Malarkey, R. P. Pautienus, J. C. Bradley, G. E. Marx, L. D. Hutcheson, and A. L. Kellner: Operational integrated optical R.F. spectrum analyzer. *Appl. Opt.*, **19**, 18, p.3033-3034 (1980).
 - 10) T. Suhara, S. Fujiwara, and H. Nishihara: Proton-exchanged Fresnel lenses in Ti:LiNbO_3 waveguides. *Appl. Opt.*, **25**, 19, p.3379-3383 (1986).
 - 11) A. Kar-Roy and C. S. Tsai: 8×8 Symmetric nonblocking integrated acoustooptic space switch module on LiNbO_3 . *IEEE Photon. Tech. Lett.*, **4**, 7, p.731-734 (1992).
 - 12) H. Okayama and M. Kawahara: Experiment on deflector-selector optical switch matrix. *Electron. Lett.*, **28**, 7, p.638-639 (1992).
 - 13) B-U. Chen, E. Marom, and A. Lee: Geodesic lenses in single-mode LiNbO_3 waveguides. *Appl. Phys. Lett.*, **31**, 4, p.263-265 (1977).
 - 14) C. Warren, S. Forouhar, W. S. C. Chang, and S. K. Yao: Double ion exchanged chirp grating lens in lithium niobate waveguides. *Appl. Phys. Lett.*, **43**, 5, p.424-426 (1983).
 - 15) S. Valette, A. Morque, and P. Mottier: High-performance integrated Fresnel lenses on oxidised silicon substrate. *Electron. Lett.*, **18**, 1, p.13-15 (1982).
 - 16) D. Y. Zang and C. S. Tsai: Titanium-indiffused proton-exchanged waveguide lenses in LiNbO_3 for optical information processing. *Appl. Opt.*, **25**, 14, p.2264-2271 (1986).
 - 17) N. Sugiyama: Perfluoropolymers Obtained by Cyclopolymerization and Their Applications. *Modern Fluoropolymers*, John Wiley&Sons Ltd., 1997, p.541-555.



Koji Tsukamoto received the B.S., M.S., and Ph.D. degrees in Material Engineering from Nagoya Institute of Technology, Nagoya, Japan in 1984, 1986, and 1992, respectively. He joined Fujitsu Laboratories Ltd., Atsugi, Japan in 1986, where he has been engaged in research and development of materials for optical and photonic devices. He is a member of the Japan Society of Applied Physics (JSAP).

E-mail: ktsuka@flab.fujitsu.co.jp



Tomoko Miyashita received the B.S. degree in Materials Science and Ceramic Technology from Shonan Institute of Technology, Fujisawa, Japan in 1993. She joined Fujitsu Laboratories Ltd., Atsugi, Japan in 1993, where she has been engaged in research and development of materials for optical and photonic devices.

E-mail: tomato@flab.fujitsu.co.jp



Akio Sugama received the B.S. degree in Chemistry from Tohoku University, Sendai, Japan in 1985. He joined Fujitsu Laboratories Ltd., Atsugi, Japan in 1985, where he has been engaged in research and development of biosensors and materials for optical and photonic devices. He is a member of the Chemical Society of Japan.

E-mail: sugama.akio@jp.fujitsu.com



Masayuki Kato received the B.S. and M.S. degrees in Applied Physics from Tokyo Institute of Technology, Tokyo, Japan in 1981 and 1983, respectively. He joined Fujitsu Laboratories Ltd., Atsugi, Japan in 1983, where he has been engaged in research and development of holographic optical elements and material engineering for optical and photonic devices. He is a member of the Optical Society of America (OSA);

Society of Photo-Optical Instrumentation Engineers (SPIE); Institute of Electronics, Information and Communication Engineers (IEICE) of Japan; and Japan Society of Applied Physics (JSAP).

E-mail: mkato@jp.fujitsu.com



Yukiko Wakino received the B.S. degree in Chemistry from Japan Women's University, Tokyo, Japan in 1993. She joined Fujitsu Laboratories Ltd., Atsugi, Japan in 1993, where she has been engaged in research and development of materials for optical and photonic devices.

E-mail: yukiko@flab.fujitsu.co.jp