

Servo Track Writing Technology

●Yukihiro Uematsu ●Masanori Fukushi

(Manuscript received September 11, 2001)

To achieve an ultra high track density in hard disk drives, the track-following performance should be improved by using micro-actuators and other new technologies. For practical use of an ultra high-density drive, it is essential to develop a new servo track writer. This paper introduces the high-precision, high-efficiency, low-priced servo track writers we have developed that use a newly developed sheet scale.

1. Introduction

The recording area density of hard disk drives is now increasing vigorously at a rate of over 100% a year. In addition, the trend is to increase the track density (TPI: Tracks Per Inch) to avoid thermal degradation in magnetic recording, rather than to increase the bit density (BPI: Bits Per Inch), and the rate of increase of TPI is expected to exceed 50% a year. This year, Fujitsu



Figure 1
Servo track writers in a product line.

and other companies delivered drives with 60 000 TPI (track pitch is 0.42 μm) and drives with more than 90 000 TPI (track pitch is 0.28 μm) will be delivered next year. In order to realize an ultra high TPI, it is necessary to greatly reduce track misregistration. For this purpose, it is necessary to reduce the amount of repeatable position errors (RPEs) and improve the writing accuracy of the position error signals (PESs) of servo track writers (STW). At the same time, it is necessary to reduce the amount of non-repeatable position errors (NRPEs) by using fluid dynamic bearings and/or piggyback actuators.¹⁾ On the other hand, the number of STWs in the production line (**Figure 1**) must be increased at an annual rate of at least 50%, because it takes more time for the STWs to write the increased number of tracks. Manufacturers are forced to make an enormous investment every year to secure sufficient facilities, including clean room spaces. Because of this situation, there is a strong requirement for a low-priced STW that can write quickly and efficiently. This paper introduces a new, low-priced, high-efficiency STW system that can satisfy the various writing requirements described above.

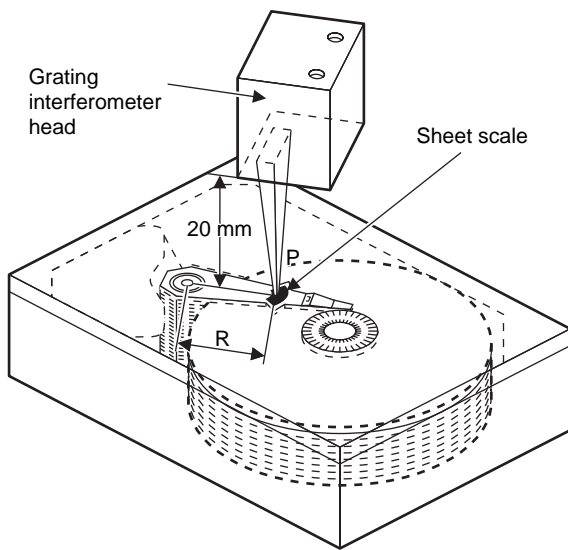

Figure 2
Conceptual design.

2. Concepts

The concept of the pushpin-free STW is shown in **Figure 2**. This STW is mounted with a new position detector that includes a small, light-weight sheet scale on the head arm and the grating interferometer head. The STW can directly detect the position of the head arm with the sheet scale and the interferometer head using a semiconductor laser.

Figures 3 and **4** show the concepts of the STW in comparison with other systems. Note that the STW actuators and the drive actuators are actually coaxial, but they are shown with different axes in the figures to illustrate the concepts more clearly.

Figure 3 shows the pushpin-type STW that is used most often these days. This system is mounted with a large STW actuator to support the pushpin. Since it has a large moving mass, its weak point is that it cannot fully resist disturbances because the servo bandwidth of STW systems is limited to the narrow range of 200 to 300 Hz. Other disadvantages are that component vibration and friction between the drive's head arm and the STW pushpin can cause degradation. In addition, the STW must be inside a clean room,

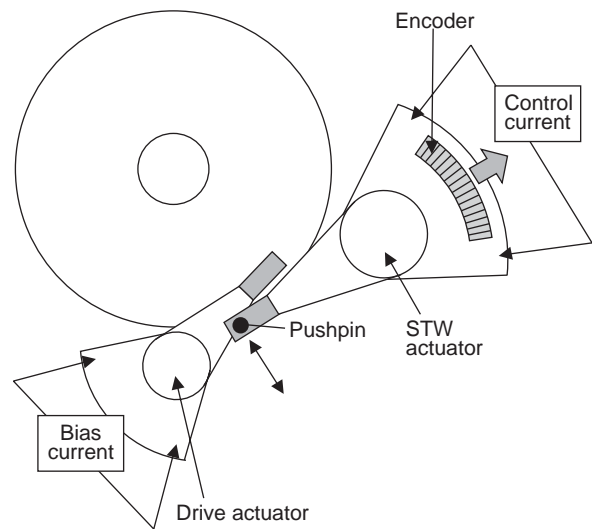

Figure 3
Pushpin STW.

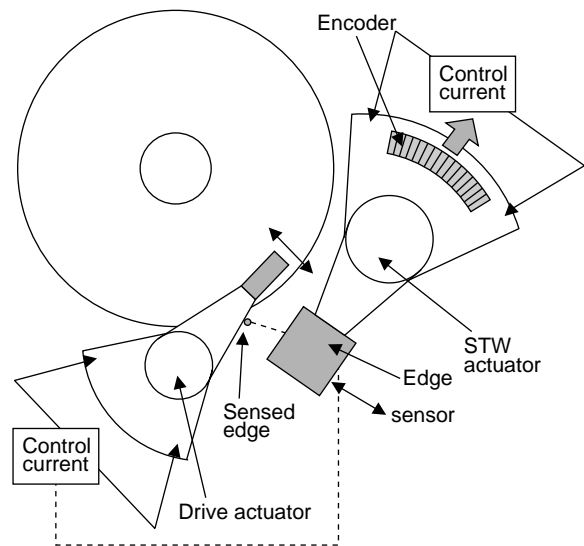

Figure 4
Non-contact pushpin STW.

because there must be holes in the drive covers for the pushpin and clock head.

Figure 4 shows a non-contact pushpin type STW proposed by several encoder vendors. This is a double servo system. The first servo positions the STW arm using a normal encoder, and

the second one positions the head arm using an edge sensor. The head arm is controlled to keep a constant distance between the sensed edge mounted at the tip of the head arm and the edge sensor on the STW arm. This system will not cause friction between the head arm and the pushpin, but it has the disadvantage that it cannot accurately control the edge sensor at high speeds because it has a lower sensitivity than current encoders. It can be installed outside a clean room if it is combined with an optical clock head; however, in this case, the holes in the cover must be covered with a transparent sheet.

Figure 5 shows the pushpin-free STW that is the subject of this project. An extra actuator is not required because 1) the design directly detects the position of the head arm from a sheet scale mounted on the head arm and 2) it controls the driving current of the VCM of the drive. Therefore, the moving mass of the STW is small because it is only the moving mass of the drive's actuator and it can fully resist disturbances, for example air turbulence and vibrations from external sources, nearly solving the imperfections of other systems that react to coupled vibration and friction.

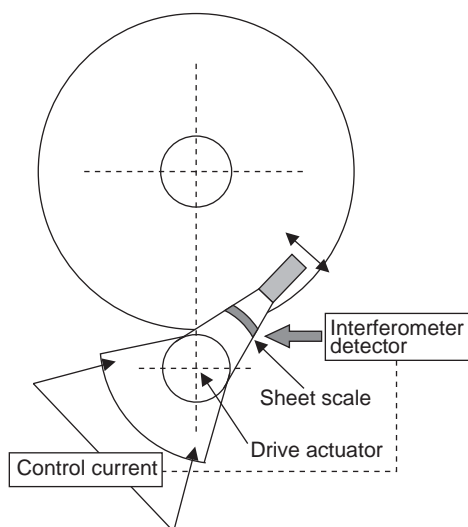

Figure 5
Pushpin-free STW.

The sheet scale is a printed diffraction grating having a $1\ \mu\text{m}$ pitch, which produces an optical source signal having a $0.25\ \mu\text{m}$ pitch. The scales currently being used have a $10\ \mu\text{m}$ pitch, and their optical source signals have a $5\ \mu\text{m}$ pitch. Therefore, the sensing resolution of the new position detector is $0.5\ \text{nm}$, which is much more accurate than the $10\ \text{nm}$ resolution of the current detector. However, this is not important for the pushpin-free STW; the important thing is that the new sensing system is less sensitive to the vertical vibration of the head arm than the edge sensor of the non-contact pushpin STW. **Figure 6** shows the new scales and detectors.

The new STW can be used outside the clean room if it is combined with an optical clock head. The only disadvantage in this case would be the cost of the sheet scale, which remains bonded to the head arm. Reduction of this cost is a major issue.

3. Results of servo track writing

The development was conducted using low-end, 3.5-inch, 5400 rpm, 2-platter drives for desktop PCs. (**Figure 7** shows a 2.5-inch drive used for the trial.)

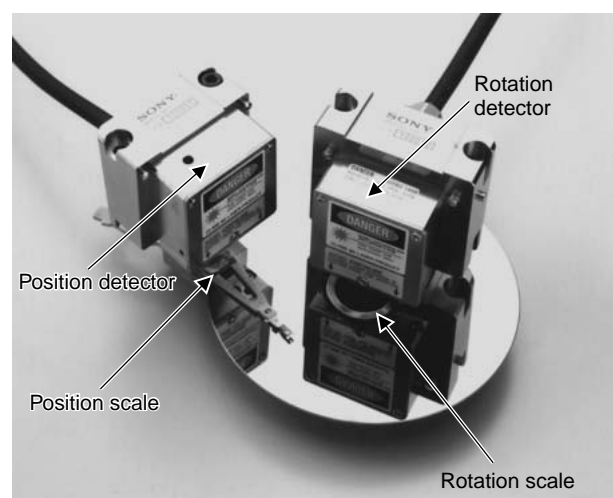

Figure 6
New scales and detectors.

Figure 8 shows the open-loop function of the pushpin-free STW. Because the new design has no pushpin arm or other additional masses and all the moving components are lightweight, the servo bandwidth can be extended to as much as 1345 Hz, which is much wider than the 250 Hz band of the pushpin STW.

Figures 9 and **10** show the drive-head-

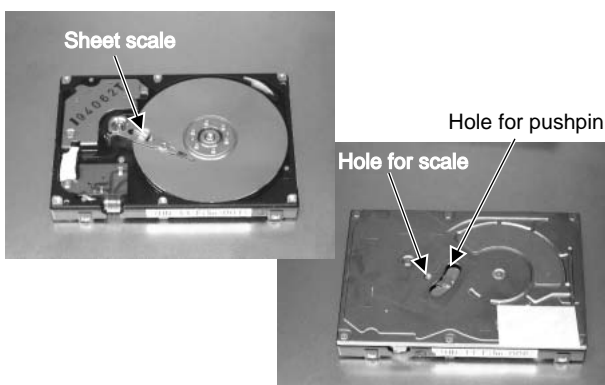

Figure 7
2.5-inch drive used for the trial.

position frequency responses of the two types of STWs versus the STW actuator current. The slope of the pushpin-free STW is very smooth and that of the pushpin STW has a sharp peak caused by component vibration of the head arm and pushpin arm. This vibration limits the servo bandwidth and the performance of the current pushpin STW.

The position error signal (PES) spectrums of

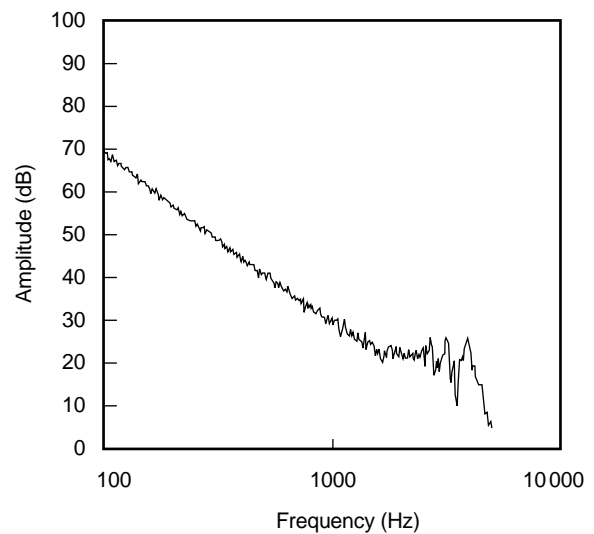

Figure 9
Frequency response of pushpin-free STW.

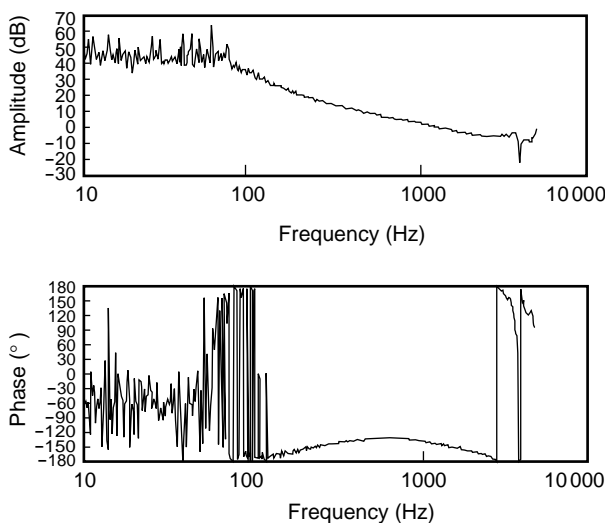

Figure 8
Open-loop function.

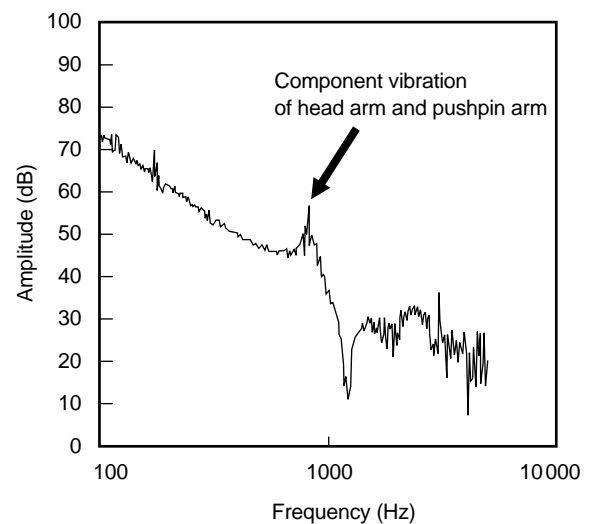

Figure 10
Frequency response of pushpin STW.

the conventional STW and the pushpin-free STW are shown in **Figures 11** and **12**. The servo systems of the STWs were used for the write and read positioning.

The current pushpin STW has the component vibration of the head arm and pushpin arm. And the impact of air disturbance in the low-frequency region is larger than that of the pushpin-free STW. Therefore, the non-repeatable position error (NRPE) of the pushpin STW is 0.088 μm , which is larger than the 0.079 μm value of the pushpin-free STW. The amount of NRPE affects the accuracy of servo writing.

We conducted a test to compare the RPEs of a conventional pushpin STW and our new pushpin-free STW. First, we wrote servo tracks onto seven drives using the conventional pushpin STW and obtained the maximum RPE values in three 100-cylinder groups of each drive, yielding a total of 21 values (3 groups \times 7 drives). The groups consisted of 100 inner cylinders, 100 middle cylinders, and 100 outer cylinders, all heads were sampled in the test, and the servo systems of the drives themselves were used for the measurements. The procedure was then repeated on the

same drives using the new pushpin-free STW. **Figure 13** pairs together the 21 RPE values for the two types of STWs. The x-axis positions of each plot indicate the maximum RPEs for the pushpin STW, and their y-axis positions indicate the corresponding RPEs for the new STW.

We found that, compared to the pushpin STW, the pushpin-free STW had on average a 14% lower RPE and an improved writing quality.

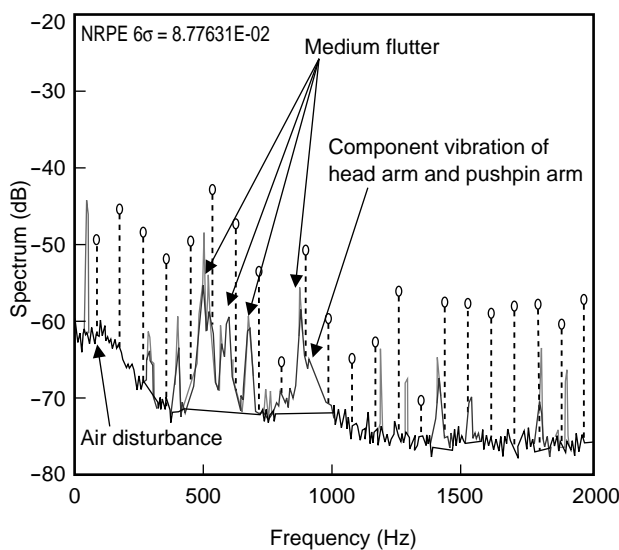

Figure 11
PES spectrum of pushpin STW.

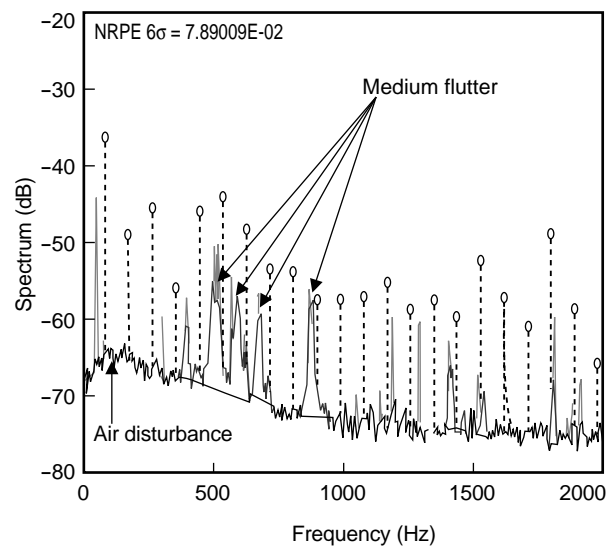

Figure 12
PES spectrum of pushpin-free STW.

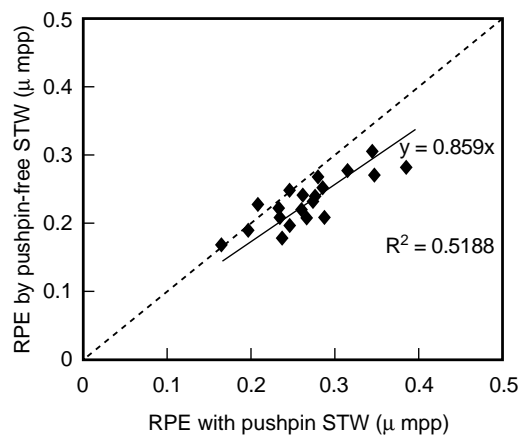

Figure 13
Comparison of RPEs.

Figure 14 shows that the 1/3 track seek time was reduced from 5.0 ms to 1.5 ms by increasing the servo bandwidth. The time required to write the servo tracks for a single drive was reduced by 25%, from 12 to 9 minutes. Also, the cost of the STW equipment was reduced by \$2000 with the elimination of the STW actuator.

Using printing technology, we can solve the major problem of the cost of the sheet scales, and we expect to be able to limit the unit price to below 10 cents/drive.

Table 1 compares the performance of the conventional STW and the STW developed in this project.

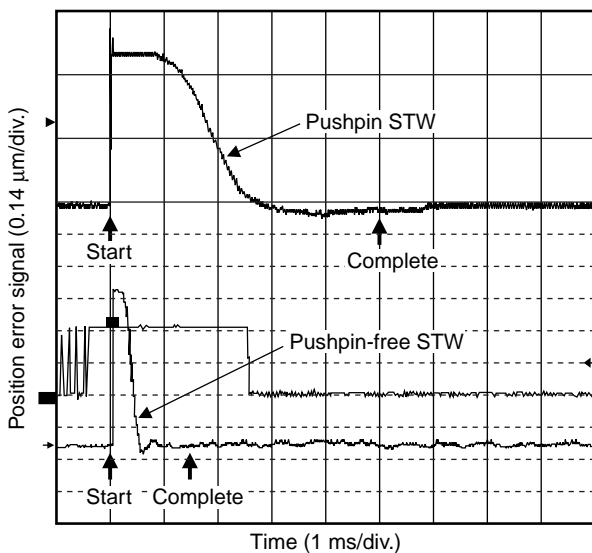

Figure 14
1/3 track seek profile.

Table 1
STW performance comparison.

	Conventional STW	New STW
Servo bandwidth	250 Hz	1345 Hz
NRPE 6σ on STW	0.088 μm	0.079 μm
RPE pp on drive	0.125 μm	0.107 μm
1/3 track seek	5.0 ms	1.5 ms
STW time	12 min	9 min
Equipment cost/station	\$25 000	\$23 000
Running cost (α)/drive	α	α + ϵ10

4. Conclusion

The moving mass of an STW was greatly reduced by employing a positioning detector using a new, high-precision, ultra-lightweight, and inexpensive sheet scale and a grating interferometer. This also increased the servo bandwidth of the system to over 1 kHz. Accordingly, writing accuracy was improved by 14% and the time required for servo-track writing was shortened by 25% because of the shorter track seek time. Also, the cost of equipment can be reduced by 8%, because the number of moving components has been reduced.

The investment for the STWs required for realizing a high TPI can also be reduced by 31% because of the shortened STW time and reduced cost of STW systems.

In addition, because the positioning for the new STW is done optically without a pushpin, it can be done outside the clean room by adding an optical clock head and another sheet scale we have developed for drives. The concept is shown in **Figure 15**. One of the big benefits of this ap-

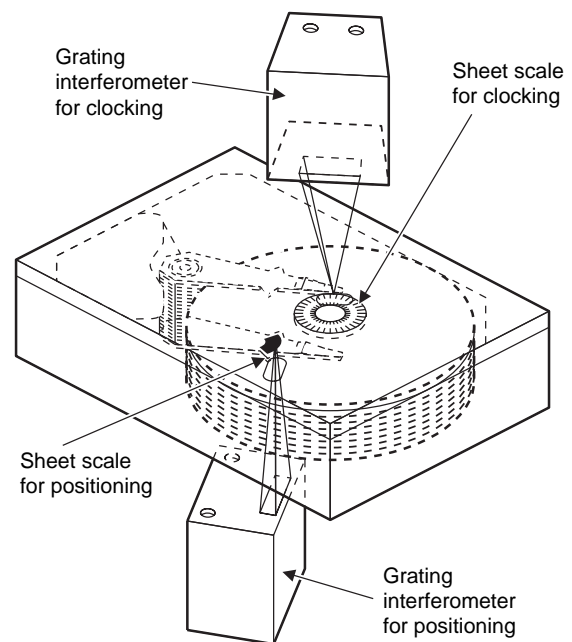

Figure 15
Conceptual design of new type STW.

proach to STW is that there is no need to provide clean spaces for the additional STWs that will be needed to cope with the increased number of tracks.

Finally, to realize an ultra-high TPI it is necessary to reduce the misregistration of heads, that is, to reduce the NRPE and RPE concurrently. Although there are a number of reports of studies on reducing NRPE, for example, by using micro-actuators, there are only a few reports on reducing RPE and on topics related to STW. It is strongly desired that more study reports on STW be published in the future to further increase the recording density of drives.

Acknowledgment

The authors would like to thank SONY PRECISION TECHNOLOGY INC., especially Kayoko Taniguchi, who developed the new position detectors for this project.

References

- 1) Y. Uematsu, S. Koganesawa, T. Imamura, Y. Soeno, S. Nakamura, K. Suzuki, M. Ataka, and H. Fujita : Piggyback Microactuators for Ultra-high Track Density Hard Disk Drive. *Sensors Update*, WILEY-VCH Verlag GmbH., **6**, p.334-358 (2000).



Yukihiro Uematsu received the B.S. degree in Mechanical Engineering from the University of Electro Communications, Tokyo, Japan in 1975. He joined Fujitsu Ltd., Kawasaki, Japan in 1975, where he was engaged in development of mechatronics for captive disk drives. He moved to the File Memory Lab., Atsugi in 1995, where he managed research and development of leading edge technologies for HDDs. Since 2000, he has been in charge of development and production of OEM HDDs. He is a senior member of the Storage Research Consortium of Japan.

E-mail: uematsu.yukihir@jp.fujitsu.com



Masanori Fukushi received the B.S. degree in Electronic Engineering from Akita University, Akita, Japan in 1980. He joined Fujitsu Ltd., Nagano, Japan in 1980, where he has been engaged in the development of servo track writers.

E-mail: fukushi@jp.fujitsu.com