

# WDM Optical Submarine Network Systems

●Masuo Suyama   ●Masato Nagayama   ●Haruki Watanabe  
 ●Haruo Fujiwara   ●Colin Anderson

*(Manuscript received April 15, 1999)*

**This paper describes optical submarine network systems that support 160 Gb/s capacity ( $10 \text{ Gb/s} \times 16\lambda$ ) per fiber. These advanced systems enable practical and cost-effective deployment of networks with 4 fiber pair optical submarine cables, and total capacity of 640 Gb/s. A typical network configuration and the relevant equipment for such networks are outlined. The equipment includes submersible wide-band repeaters, optical ADM branching units and line terminal equipment, which we have developed making full use of our advanced optical technology. Our ultra-large capacity ( $10.7 \text{ Gb/s} \times 66\lambda$ ) transmission experiment, and enabling technologies for future Tera-bit transmission systems are also summarized. New network configurations using OADM or Internet Protocol (IP) routers are proposed for next generation WDM submarine networks.**

## 1. Introduction

We have already developed and supplied submarine WDM systems for projects such as the SEA-ME-WE 3 cable system, which features 40 Gb/s capacity ( $2.5 \text{ Gb/s} \times 8\lambda \times 2$  fiber pairs). Due primarily to the explosive expansion of Internet use, demand for international traffic is currently growing at a high rate, and capacities per fiber pair of  $10 \text{ Gb/s} \times 16$  or more are now required. In order to meet this demand, we have developed the systems outlined in this paper.

## 2. Overview of 640 Gb/s submarine network utilizing $10 \text{ Gb/s} \times 16\lambda$ WDM

**Table 1** summarizes major parameters of 640 Gb/s ( $10 \text{ Gb/s} \times 16\lambda \times 4$  fiber pair) system. The system features the following technical advantages:

- Minimized system cost  
Forward Error Correction (FEC) has been employed, using the Reed Solomon 255/239 code, in order to improve system performance. We have developed dedicated IC chip sets for

this FEC using the Reed Solomon code (255/239) at data rates of 10 Gb/s (SDH STM-64), based on advanced hardware and software technology. This FEC, together with the increased output power and lower noise figure of the submersible repeaters, has enabled us to minimize the number of repeaters required for the system, thus minimizing the cost.

- Wide optical gain bandwidth  
An optical gain bandwidth of at least 12 nm is required for the  $16\lambda$  system with channel spacing of 0.8 nm. This is almost twice the bandwidth required for the previous  $8\lambda$  systems. We realized the required broad gain bandwidth by employing an Erbium Doped Fiber (EDF) with optimized dopant concentrations, and a fiber-based gain equalizer optimized to compensate for the EDF gain characteristic.
- Enhanced supervisory functions  
Monitoring the status of each repeater in the network is important for the maintenance of

Table 1  
Major parameters of 640 Gb/s (10 Gb/s × 16λ × 4 fiber pair) system.

Item	Parameter	Note
Capacity per fiber	STM-64 × 16	equivalent to 1935360 telephony voice channels
Bit rate per channel	10.664 Gb/s	
Modulation scheme	Return to Zero (RZ) code	
Signal wavelength	1548 nm ~ 1560 nm	
Forward error correction	Reed Solomon code (255/239) FEC	
Maximum system length	10000 km	for one hop between SLTE and SLTE
Repeater span	40 km ~ 90 km	depends upon total hop length
Optical fiber type	NZ-DSF + DCF or LCF + DCF	NZ-DSF: Non Zero Dispersion Shifted Fiber LCF: Large Core Fiber DCF: Dispersion Compensating Fiber
Reliability	less than 2 ship repairs	System life = 25 years
Error performance	BER < 1 × 10 <sup>-11</sup>	After error correction
Repeater supervisory	<ul style="list-style-type: none"> <li>• Input power</li> <li>• Output power</li> <li>• Pump laser diode bias</li> <li>• C-OTDR</li> </ul>	
Line powering current	1A	DC

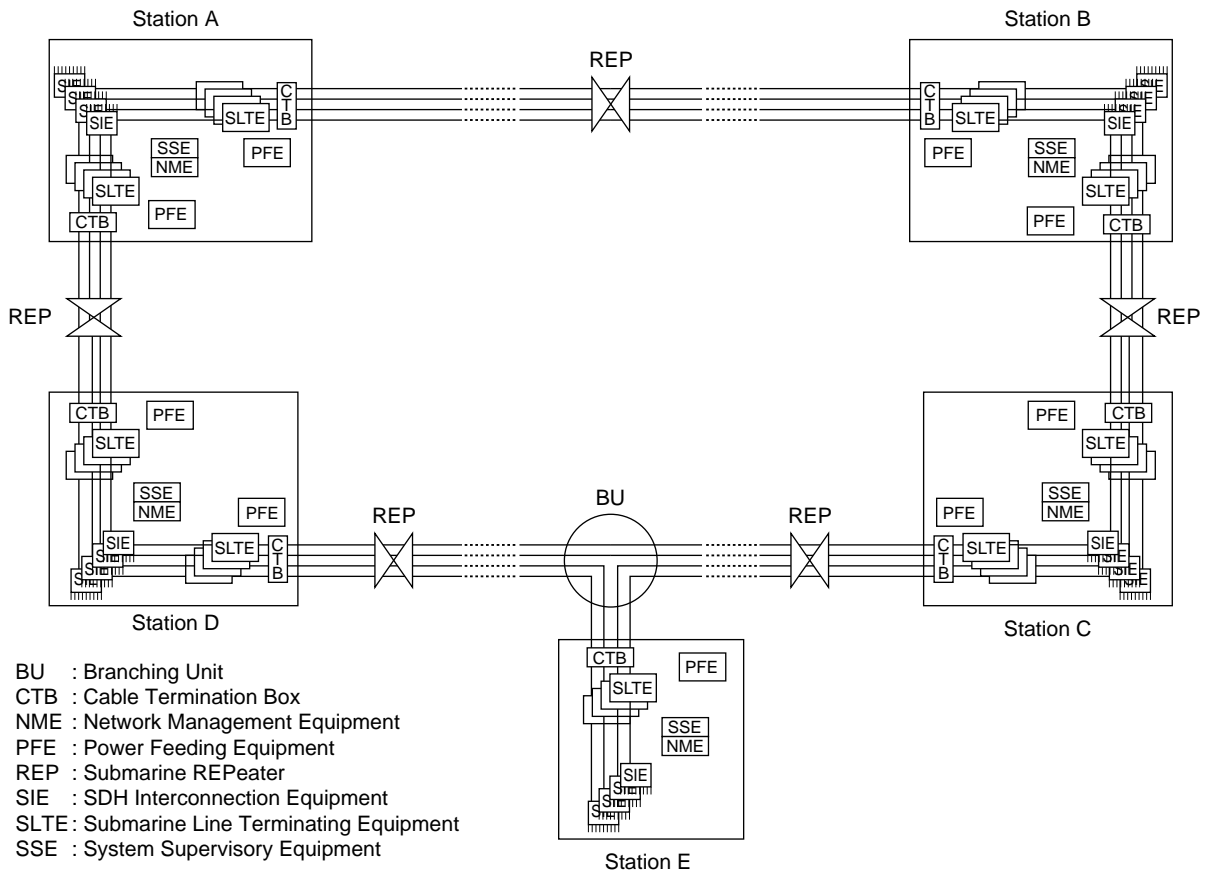

Figure 1  
Example network configuration.

large capacity submarine networks. Our supervisory system monitors and reports repeater status including parameters such as optical input power and output power, as well as pump-laser power and bias current. In addition, a coherent OTDR path is provided in each repeater, enabling precise remote fault localization as far as 10000 km from the terminal equipment.

**Figure 1** is an example network configuration. An overview of the network function of each type of equipment is given below. A more detailed description of some of the equipment including repeaters, OADM and SLTE follows in subsequent sections.

### **2.1 Submarine line terminal equipment (SLTE)**

The submarine line terminal equipment (SLTE) provides the necessary interface between the 9.95 Gb/s signal from the SDH Interconnection multiplex Equipment (SIE) and the 10.66 Gb/s signal (including the FEC overhead), as well as the wavelength division multiplex and de-multiplex functions in optical domain.

### **2.2 WDM submarine repeater (REP)**

WDM submarine repeaters are essential to realize long-distance high-capacity optical fiber submarine transmissions. The repeater span is typically 40 to 90 km depending on total system length. The repeater includes wide-band optical amplifiers equipped with a gain-flattening filter. Typical repeaters are designed for two, three or four fiber pair submarine cable. A repeater for a four fiber pair submarine cable includes 8 EDF optical amplifiers, which are powered by DC current from the PFE, fed through the center conductor of the submarine cable.

### **2.3 Submarine optical branching unit (BU)**

Submersible optical branching units provide

for some fiber pairs to terrestrial terminal stations, while passing the other fibers through. Optical Add/Drop Multiplexing BU can add/drop particular wavelengths in one fiber pair.

### **2.4 Power feeding equipment (PFE)**

The PFE equipment provides power to the repeaters by applying a DC current of typically 1.0 amp through the center conductor of the submarine cable.

### **2.5 System supervisory equipment (SSE)**

The SSE is an element manager which performs all necessary submarine system supervisory functions including the element management for the SLTE, the PFE and the repeaters. Surveillance and control of submarine repeaters is achieved by modulation of the main optical signal applied at each SLTE.

### **2.6 Network management equipment (NME)**

The SSE and the SIE element manager communicate to the overall Network Management Equipment (NME), which is comprised of dedicated software running on a UNIX workstation. This NME has the possibility to up-link to other higher network management systems by the ITU-T Q3 protocol.

### **2.7 Cable termination box (CTB)**

The CTB facilitates the connection between the optical fibers of the submarine cable and the optical patch cables to the station ODF (optical distribution frame), as well as providing the interface to the center DC power-feed conductor of the submarine cable. Submarine cables with up to 4 fiber pairs (8 optical fibers) per cable are typically deployed.

### **2.8 Network protection & SDH interconnection equipment (SIE)**

The SDH SIE equipment allows application

of the 4-Fiber MS-SPRing (Multiplex Section Shared Protection Ring) protection scheme to  $N \times 10$  Gb/s submarine networks, and includes the special requirements for trans-oceanic submarine networks. In addition, the SIE allows full access to the protection channel (PCA) for un-protected traffic (which may be lost in case the protection scheme acts to protect the main traffic in event of a cable or hardware failure).

### 3. Equipment for 10 Gb/s $\times$ 16 $\lambda$ WDM submarine links

This chapter describes details of the equipment developed specifically for 10 Gb/s  $\times$  16 $\lambda$  submarine networks. The equipment includes the WDM submarine repeater, the OADM branching unit (BU) and the WDM submarine line terminal equipment (SLTE).

#### 3.1 WDM submarine repeater

**Figure 2** shows the block diagram of the repeater for one sub-system (one fiber pair). **Table 2** shows the major parameters of the wide-band WDM repeater.

##### 3.1.1 Repeater configuration

A length of optical fibre, whose core is doped with the rare earth element Erbium, provides optical amplification. Optical energy is supplied to the Erbium doped fibre (EDF) by pump laser diodes (LD) operating at a wavelength of 1.48  $\mu$ m, which excites the Erbium ions to a higher energy

level and provides optical gain. Since the gain depends on the wavelength of an input signal, the EDF limits the transmission wavelength window. A long-period fiber grating (LPG) with an appropriate loss characteristic is employed to compensate for the gain profile of EDF. Furthermore, a high concentration of aluminium is co-doped in the EDF core, which contributes to a flattened gain profile.<sup>1)</sup> Thus, a wide gain bandwidth (12 nm) was achieved, making it suitable for transmission of 16 wavelengths.

Pump LD's are duplicated, and supply the EDF's for both transmit and receive via a coupler (CPL5). Passive wavelength division multiplexing couplers (WDM) are used to combine the input line signals at around 1.55  $\mu$ m with the pump laser signal at 1.48  $\mu$ m. Dielectric filter technology was chosen for the WDM coupler, in order to achieve a flat pass-band characteristic. An optical isolator (ISO) was designed to ensure very low levels of polarization dependent loss (PDL) and polarization mode dispersion (PMD) in the repeater. The WDM filter and isolator were integrated into compact module by making full use of our micro-optics technology.

##### 3.1.2 Repeater supervisory system

It is a requirement of the system to be able to locate faults to within one repeater section. All hardware faults involving the loss of transmission can be located using the input and output monitors of the repeater.

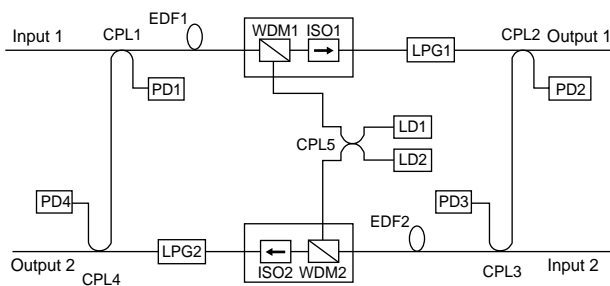

Figure 2 Configuration of wide-band WDM repeater (sub-system for one fiber pair).

Table 2 Major parameters of wideband WDM repeater.

Parameter	Value
Optical output power	+10 dBm
Noise figure	< 6 dB
Transmission window (optical bandwidth)	> 12 nm
Remote supervision	Optical input power monitor Optical output power monitor Pump laser drive current monitor
Operating temperature range	0°C to +35°C
System design lifetime	25 years

Monitoring of the input and output optical signal level is achieved by using photo diodes (PD) and couplers (CPL). The pump laser diodes' condition can be monitored by remotely monitoring their drive current.

### 3.2 Optical add/drop submarine branching unit

An Optical ADM branching unit (OADM-BU) was developed, which can add or drop any wavelengths to or from the main trunk WDM signal. **Figure 3** shows the optical circuit diagram of the OADM-BU. It utilizes fiber Bragg gratings, optical circulators and an optical isolator. The fiber grating reflects the specified wavelength, and transmits other wavelengths. The required optical add/drop function is achieved by the combination of the fiber grating and the optical circulator as shown in **Figure 3**. The fiber grating is incorporated into a temperature-compensated package

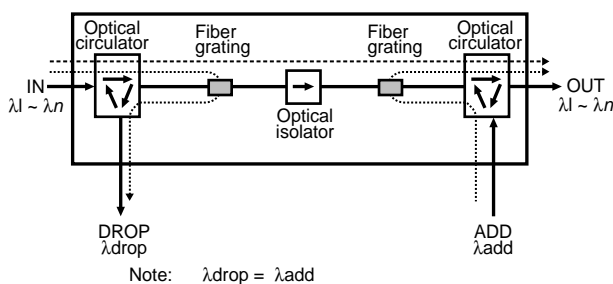

Figure 3 Optical circuit diagram of optical ADM branching unit.

Table 3 Major parameters of optical ADM branching unit.

Parameter	Typical value
Operating temperature range	0°C to +35°C
Signal wavelength	1550 nm to 1560 nm
Insertion loss	"In" to "Out": 5.8 dB "In" to "Drop": 4.0 dB "Add" to "Out": 4.0 dB
Insertion loss between "Through" wavelength and "Add/Drop" wavelength	> 36 dB
Return loss	> 35 dB
PDL	< 0.3 dB

in order to eliminate any shift of the center wavelength due to temperature variations. A perfect circulated 3-port optical circulator is used in order to still enable fault localization from the remote terminals, using coherent optical time domain reflectometry (OTDR). The optical isolator is used to suppress coherent cross-talk, which might otherwise degrade the transmission performance.

**Table 3** summarizes the major parameters of the OADM-BU. **Figure 4** shows a typical characteristic of the OADM-BU. It can be seen that good in-band amplitude flatness and sharp rejection characteristics were achieved.

### 3.3 WDM submarine line terminal equipment (SLTE) for 10 Gb/s × 16λ

The 10 Gb/s × 16λ WDM SLTE is high-speed transmission equipment used for transporting a

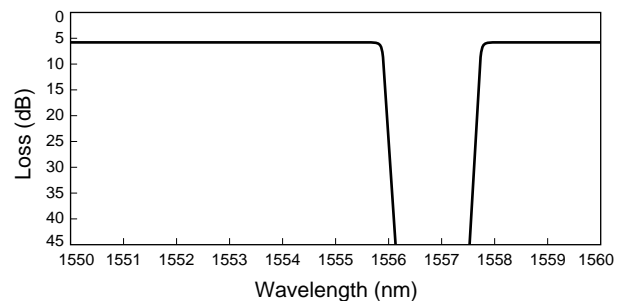

(a) "In" to "Out" characteristic

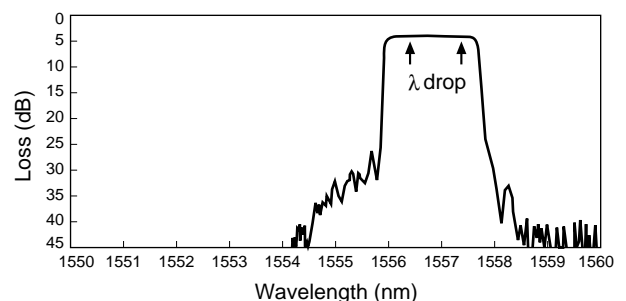

(b) "In" to "Drop" characteristic

Figure 4 Example characteristics of optical ADM branching unit (Two wavelengths Add and Drop).

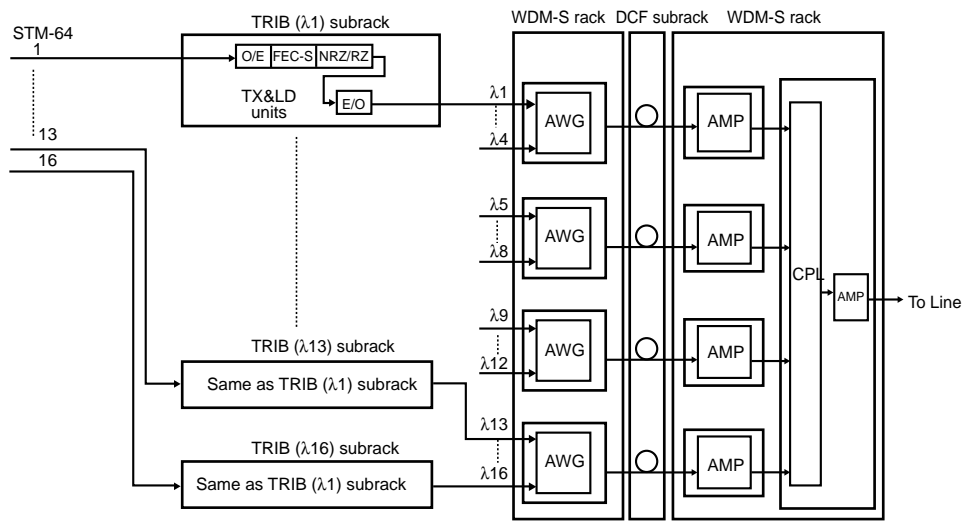

Figure 5  
SLTE block diagram (transmit side).

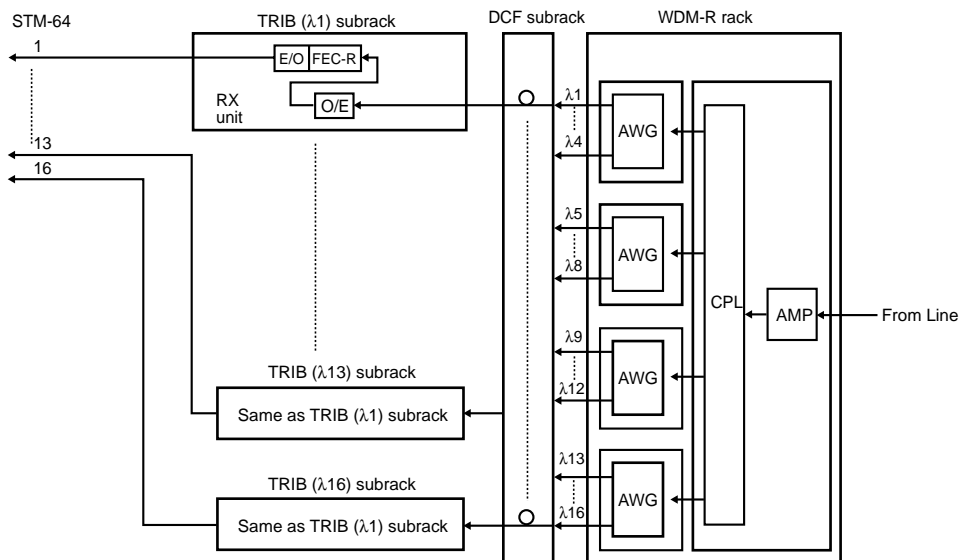

Figure 6  
SLTE block diagram (receive side).

maximum of sixteen STM-64 signals. **Figures 5 and 6** are block diagrams of main transmission path of the 10 Gb/s × 16λ WDM SLTE. To establish higher transmission performance, Reed Solomon (255/239) Forward Error Correction (FEC) is implemented in the transmission signal for each wavelength. Thus, the STM-64 signal is converted to a 10.66 Gb/s signal before being multiplexed into WDM optical line signal and

transmitted to the far end via the submarine repeaters. The received optical line signal is de-multiplexed to each wavelength signal by the SLTE, and then converted to an electrical signal. The functions of the SLTE are as follows:

- 1) Conversion between the 9953.28 Mb/s (STM-64) SDH data signal and the submarine line signal (10664.22857 Mb/s including the FEC processing)

- 2) Optical amplification of the transmit and receive signals
- 3) Wavelength division multiplexing and demultiplexing of the signal
- 4) Dispersion compensation using dispersion compensating fiber, for both transmit and receive
- 5) Monitoring and displaying of relevant alarms
- 6) Provision of line supervisory interface.

In the transmit side of the SLTE, the STM-64 SDH signal is converted to an electrical signal, and is multiplexed with redundant bits for FEC, thus producing the 10.66 Gb/s signal. This is converted to an optical signal with appropriate wavelength in TRIB sub-rack of the SLTE. A maximum 16 channels are multiplexed into one optical line signal using the arrayed waveguide grating (AWG) and CPL blocks in the WDM-S rack of the SLTE.

In the receive side of the SLTE, the line signal is amplified and de-multiplexed into separate wavelength signals in WDM-R rack. After decoding the FEC bits, each signal is converted to an STM-64 SDH signal in the TRIB sub-rack of the SLTE.

In order to minimize waveform distortion due to chromatic dispersion, dispersion compensation at both transmit and receive side is necessary.<sup>2)</sup> The necessary dispersion compensating fibers (DCF) to accomplish this are accommodated in the DCF sub-rack of the SLTE.

Overhead bytes in the FEC frame are also used for provision auxiliary plesiochronous data channels (2.048 Mb/s), 64 kb/s data channels, and voice channels for engineering orderwire.

The SLTE equipment also performs surveillance and control of submarine repeater and has the alarm and supervisory capability. This equipment has a display interface to indicate relevant alarms and status, which involves receiving and sending data from or to the System Supervisory Equipment (SSE).

### 3.4 Current network protection architectures

SDH MS-SPRing network protection configuration (similar to the BLSR (Bi-directional Line Switched Ring) configuration in SONET networks) is currently the most attractive for large high-capacity submarine networks. MS-SPRing is already widely used in terrestrial networks, and is preferred over unidirectional Path Switched Ring protection schemes, since it allows the re-use of circuit capacity on a node-to-node basis and access to the protection channel is possible with appropriate SIE equipment. Some specific adaptations to the usual MS-SPRing protocol are required for submarine network applications, to prevent hairpin protection over trans-oceanic routes. The SDH protection scheme is provided by the SIE equipment.

## 4. Technologies for future submarine network systems

To meet the increasing demand for network capacity, which is mainly driven by the growth in Internet services, new and advanced technologies are required for end-to-end transmission capacity and also for network protection architecture. This chapter discusses some of the enabling technologies for Tera-bit transmission and future network configurations.

### 4.1 Enabling technologies for tera-bit transmission in real networks

Major limiting factors for the realization of Tera-bit transmission include SNR degradation, gain bandwidth, and waveform distortion due to chromatic dispersion and non-linear optical effects. Various technologies seem to hold promise in addressing these limitations:

- Improved SNR achieved by using lower noise repeaters, such as achieved by utilizing 980 nm pump lasers
- Broad bandwidth achieved by accurate gain equalization and by exploiting L-band EDFA optical amplifiers

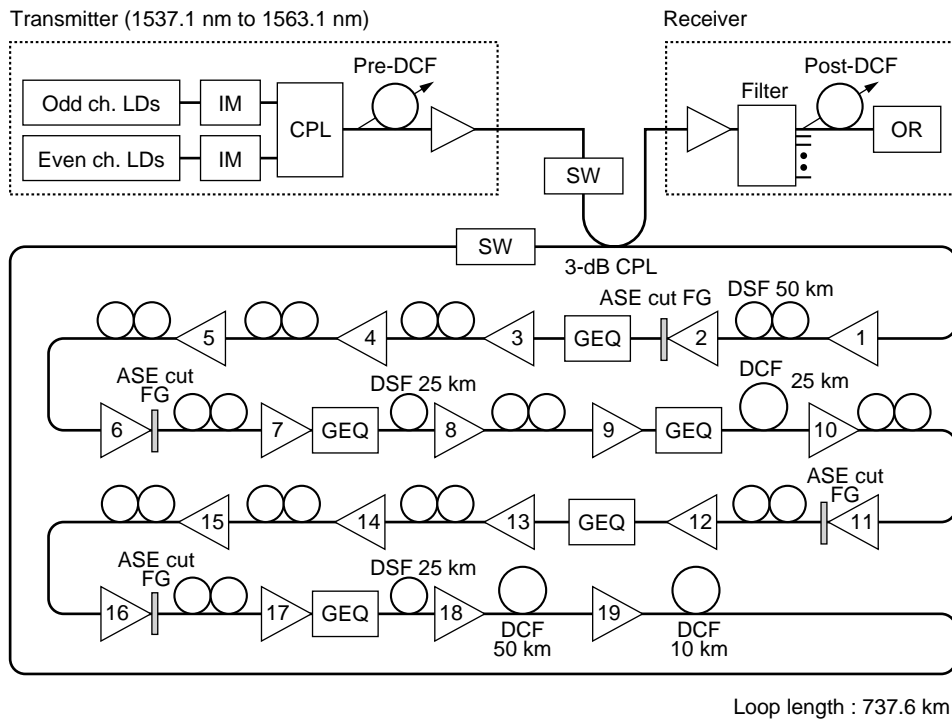

Figure 7 Experiment setup.

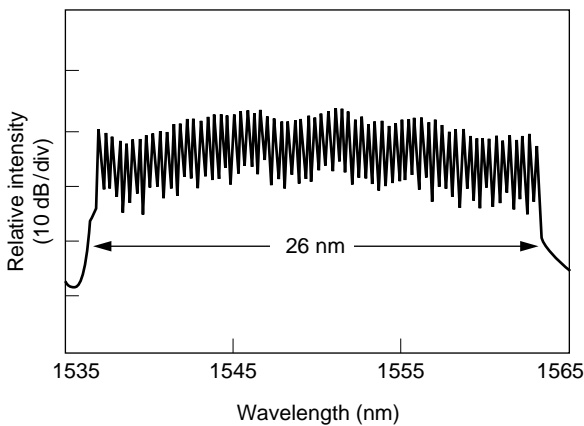

Figure 8 Optical spectrum after 2212 km.

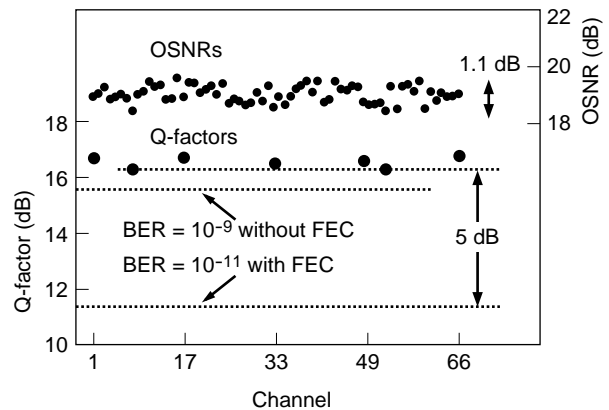

Figure 9 Transmission performance (Optical SNR and Q factor).

- Reduced power density and chromatic dispersion compensation achieved by utilizing new types of optical fiber.

We have already successfully demonstrated transmission of  $10.7 \text{ Gb/s} \times 66\lambda (= 0.7 \text{ Tb/s})$  over 2212 km by employing some of the above technol-

ogies.<sup>3)</sup> **Figure 7** shows the configuration of the relevant transmission experiment. The noise figure of the optical amplifiers was as low as 4.9 dB with +13 dBm output power, which was realized by efficient pumping at 1.48  $\mu\text{m}$  using a pump reflector. We compensated for the asymmetric gain profile by using GEQs with different free spectral

ranges, resulting in a bandwidth of 26 nm after transmission over 2212 km (**Figure 8**). A good transmission performance was confirmed in terms of optical SNR and Q factor (**Figure 9**).

These technologies combined with the new optical fiber featuring large effective area, and dispersion compensation up to the third order,<sup>4)</sup> will enable the practical realization of Tera-bit transmission in networks over transoceanic distances.

## 4.2 Future high capacity network architectures

Telecommunication backbone networks will in the near future evolve into data networks which accommodate voice, video, IP and other telecommunication services. A submarine network system which can satisfy the requirements of this evolution, and also features more economical and flexible configuration is described.

### 4.2.1 Network configurations using OADM and OPSW

**Figure 10** shows a ring-configuration submarine network configuration using an Optical Add / Drop Multiplexer (OADM) at the terminals. The OADM can add or drop and pass through any desired wavelength signals in optical layer, by using appropriate optical filters. The OADM sends the wavelength multiplexed signal on to the SLTE. For protection against possible line or equipment failure, the optical protection switch (OPSW) with Transoceanic Ring Protection mode, is supported in this configuration.

The special features in this configuration are as follows:

- 1) Transparency to any digital hierarchy
- 2) High reliability by using the OPSW
- 3) Add/Drop and Through any wavelength in the optical layer
- 4) Effective use of the wavelength in the ring network.

This configuration can exclusively assign wavelengths for various telecommunication services and signals in the optical layer. In addition,

an Optical ADM developed for use in terrestrial networks can easily be deployed in submarine networks using this configuration.

### 4.2.2 Network configurations using OPSW without OADM

In case of the fixed connection of the wavelengths in the optical layer, it is possible to connect the OPSW to the SLTE directly, without using the OADM (**Figure 11**). This configuration allows the deployment of systems at a lower cost, while still maintaining the high network reliability offered by the OPSW.

### 4.2.3 Network configurations using an IP router

Recently, telecommunication services using Internet protocol (IP) are developing very quickly. It is now important to apply the IP technology to the submarine cable networks, as the international backbone network also shifts towards an IP based network. **Figure 12** shows a possible network configuration using IP routers, where a high capacity IP router is connected directly to the SLTE. In the event of a network failure, traffic can be restored by the routing protocol of the IP router. The system has the following features:

- 1) Efficient transportation of IP traffic
- 2) Lower cost for network equipment
- 3) Easy integration with other networks using IP protocols
- 4) Simplified network architecture and protection
- 5) The possibility to protect the network using the routing protocol.

Therefore, this configuration seems promising for future submarine networks.

## 5. Conclusions

We have described a practical and cost-effective 640 Gb/s ( $10 \text{ Gb/s} \times 16\lambda \times 4$  fiber pair) optical submarine network system, together with the network configuration and relevant equipment. In particular, the new submersible wide-bandwidth optical repeater, optical ADM branching unit, and submarine line terminal equipment were detailed.

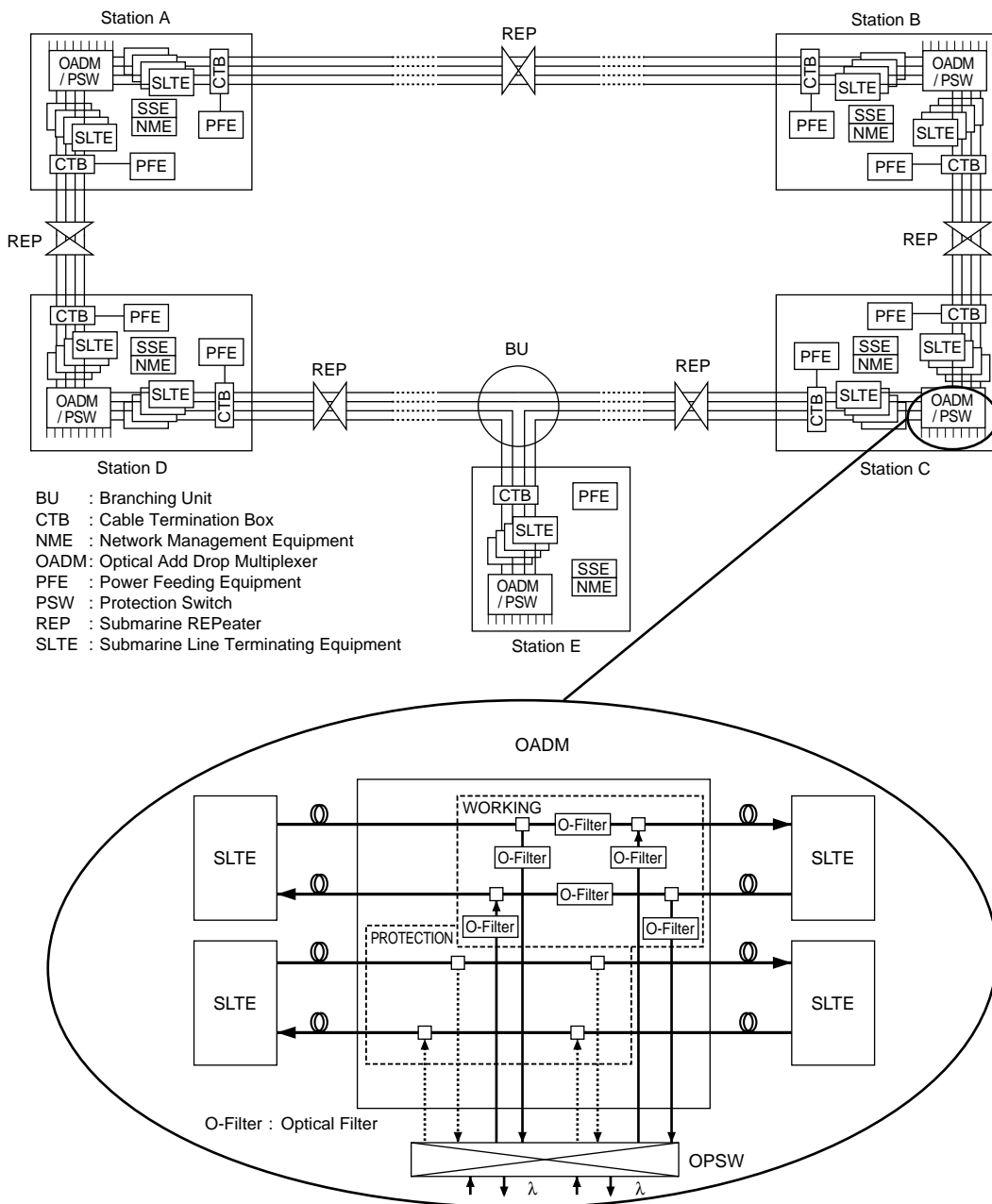

Figure 10 Ring submarine network configuration using OADM.

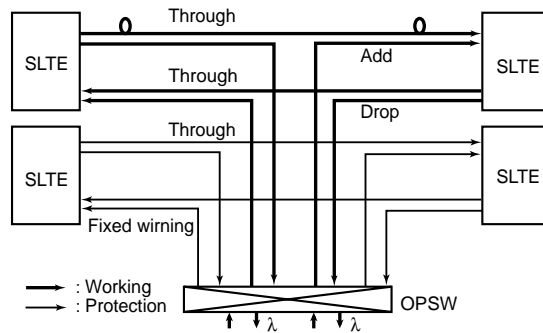

Figure 11 Connection configuration between SLTE and OPSW.

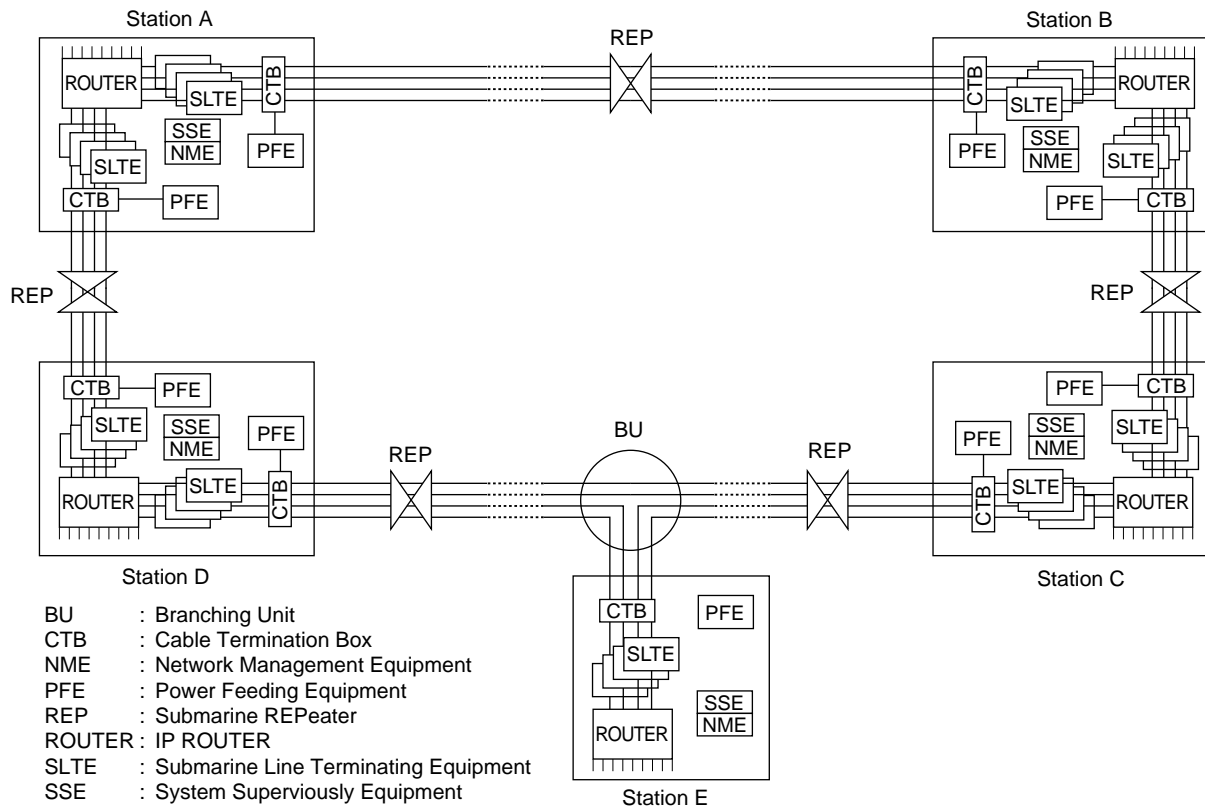

Figure 12  
 Ring submarine network configuration using the IP Router.

Enabling technologies for future Tera-bit transmission networks were discussed, referring to our 0.7 Tb/s ( $10.7 \text{ Gb/s} \times 16 \times 66\lambda$ ) transmission experiment, and new network configurations using OADM or IP routers were proposed for next-generation of WDM submarine networks.

## References

- 1) T. Naito, N. Shimojo, T. Terahara, T. Tanaka, T. Chikama, and M. Suyama: Long-haul WDM transmission system by use of high Aluminum codoped EDFAs and gain-equalizers. GLOBECOM'98, Sydney, pp.993-997, November, 1998.
- 2) T. Naito, T. Terahara, T. Chikama, and M. Suyama: Four 5-Gb/s WDM transmission over 4,760 km straight line using pre- and post-dispersion compensation and FWM cross talk reduction. OFC'96, San Jose, WM3, February, 1996.
- 3) T. Terahara, T. Naito, N. Shimojo, T. Tanaka, T. Chikama, and M. Suyama: 0.7 Tbit/s ( $66 \times 10.66 \text{ Gbit/s}$ ) WDM transmission over 2,212 km using broadband, high-power EDFAs with pump reflector. *Electron. Lett.* **34**, 10, pp.1001-1002 (May 1998).
- 4) M. Murakami, H. Maeda, and T. Imai: Long-haul  $16 \times 10$  WDM transmission experiment using higher order fiber dispersion management technique. ECOC'98, Madrid, TuC28, September, 1998.



**Masuo Suyama** received B.E. and M.E. degrees in Applied Physics from the University of Tokyo, Tokyo, Japan, in 1980 and 1982, respectively. He joined Fujitsu Laboratories Ltd., Kawasaki in 1983 and was engaged in research and development of optical amplifiers and their system applications. Since 1994, he has been with submarine telecommunications division of Fujitsu Ltd., working on system design. He is a member of the Institute of Electronics, Information and Communication Engineers (IEICE) of Japan.

member of the Institute of Electronics, Information and Communication Engineers (IEICE) of Japan.

E-mail : suyama@ost.ts.fujitsu.co.jp



**Haruo Fujiwara** received B.S. and M.S. degrees in Electrical Engineering from Osaka University, Osaka, Japan in 1973 and 1975, respectively. He joined Fujitsu Laboratories Ltd., Kawasaki in 1975 and transferred to Fujitsu Ltd. in 1985. He has been engaged in the development of optical submarine repeaters and branching units. He is a member of the Institute of Electronics, Information and Communication Engineers (IEICE) of Japan.

neers (IEICE) of Japan.

E-mail : fujiwara@ost.ts.fujitsu.co.jp



**Masato Nagayama** received a B.E. degree in Electrical Engineering from the Science University of Tokyo, Tokyo, Japan in 1989. He joined Fujitsu Ltd., Kawasaki, in 1989 and has been engaged in the research and development of data communication network systems for 9 years. Since 1998 he has been engaged in the research and development of submarine cable network systems.

E-mail : nagayama@ost.ts.fujitsu.co.jp



**Colin Anderson** received a B.Sc. degree, majoring in Physics from Victoria University, Wellington, New Zealand in 1975. In 1988 he received an MBA degree from the Victoria University Graduate School of Business and Government. After 12 years with Philips NZ Ltd., in both engineering and marketing roles, he joined Fujitsu NZ Ltd. in 1986. In 1992 he moved to Tokyo Japan, to take up a position in the International Telecommunications Business Group of Fujitsu Limited.

He is currently Business Development Manager for Submarine Networks Sales & Marketing in the International Telecommunications Business Group. He is a member of the IEEE Communications Society.

E-mail : anderson@tel.fujitsu.co.jp



**Haruki Watanabe** received B.E. and M.E. degrees in Electronics Engineering from Nihon University, Tokyo, Japan in 1980 and 1982, respectively. He joined Fujitsu Ltd., Kawasaki in 1982, where he was engaged in research and development of submarine line terminal equipment. He joined Fujitsu Kyushu Digital Technology Ltd., Fukuoka in 1999. He is a member of the Institute of Electronics, Information and Communication Engineers (IEICE) of Japan.

ication Engineers (IEICE) of Japan.

E-mail : hwata@qdt.ts.fujitsu.co.jp