

Digital Cross-Connect System (DCS) Aggregation and Grooming Solutions

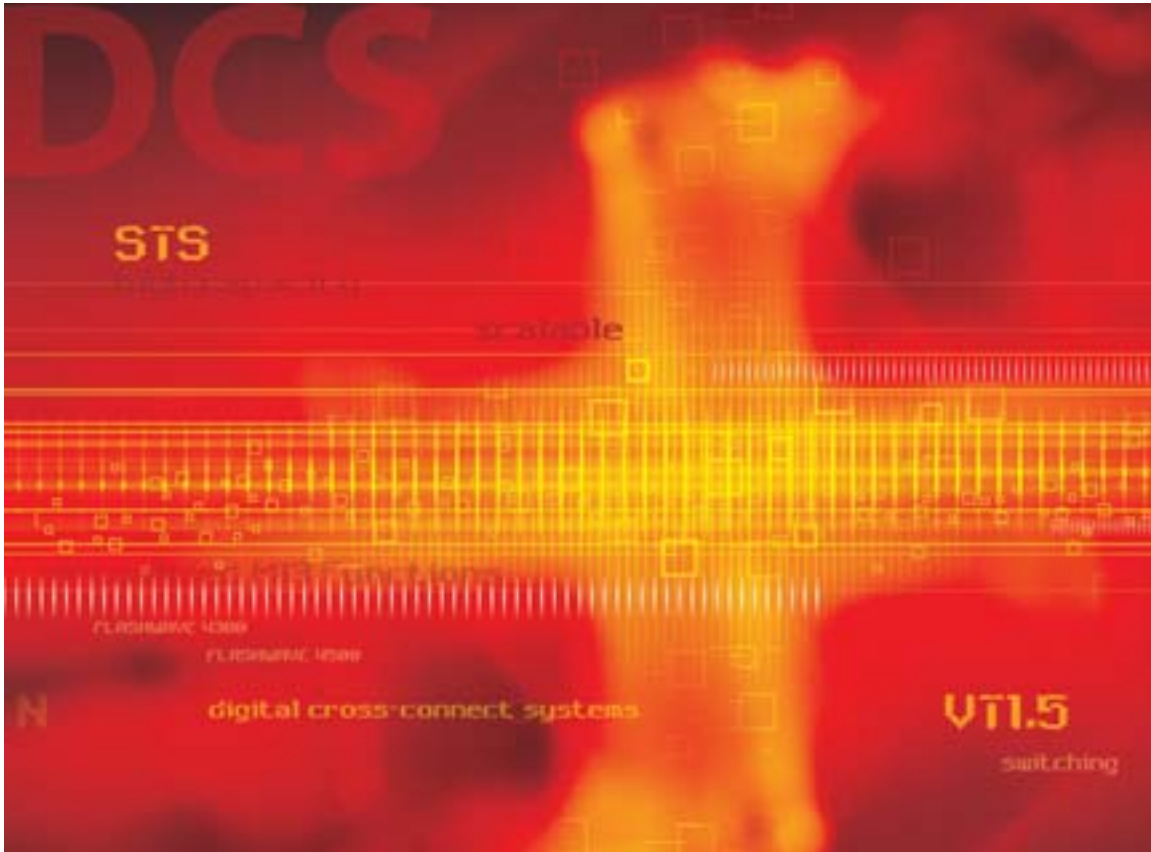

FLASHWAVE™

Introduction

Platforms in the Fujitsu FLASHWAVE® 4000 series set the standard for next-generation, multiservice products, delivering advanced, cost-effective solutions for a carrier's voice, video and data network requirements. Each product combines the proven transport functionality of a SONET Add/Drop Multiplexer (ADM), the switching capabilities of a Digital Cross-Connect System (DCS), and the interfaces for traditional and next-generation services. By integrating these capabilities into compact, scalable products optimized for specific areas in a carrier's network, Fujitsu provides the necessary tools to simplify Central Offices (COs), while reducing Capital Expenses (CAPEX) and Operating Expenses (OPEX).

DCS aggregation and grooming has emerged as one of the key applications for two platforms in the FLASHWAVE 4000 series. The FLASHWAVE 4300 multiservice access grooming platform and FLASHWAVE 4500 multiservice core grooming platform can work independently or as a team to give service providers a truly scalable DCS functionality in small to medium CO applications. When compared to traditional DCS approaches that require a large, complex node to provide all switching functionality, the Fujitsu approach, with distributed DCS grooming, provides a lower initial cost and can be scaled to support specific network needs. By combining transport and switching capabilities into a single platform, the complexity, training, power, space and other costs reduce recurring OPEX. In addition, the Fujitsu approach eliminates a carrier's dependence on old, asynchronous, stand-alone M13 multiplexers and their associated maintenance-intensive, manual DSX-3 connections, providing significant reductions in OPEX.

Scalable M13 Multiplexing

Fujitsu was one of the pioneers in ADM-integrated M13 technology, providing a simple transmux solution incorporated into its FLM 150 ADM and FACTR® access/transport system in the mid-1990s. With the release of the FLASHWAVE 4300 platform, Fujitsu has expanded the capabilities of M13 multiplexing to support four distinct operating modes to satisfy a wide variety of network requirements (see Figure 1).

The FLASHWAVE 4300 platform provides M13 multiplexing using a three-port DS3 Transmux card that can be inserted into any of 12 flexible service slots. As such, the FLASHWAVE 4300 platform supports up to 36 unprotected or 18 protected DS3 transmux connections per shelf. A 14-port DS1 card is also available to allow up to 168 DS1 connections dropped from a single FLASHWAVE 4300 shelf. STS switching is supported with full Time Slot Interchange (TSI) for 240x240 STS-1. For networks that require large amounts of VT1.5 switching, the FLASHWAVE 4300 platform is ideal with its 2688x2688 VT1.5 switching fabric. An additional pair of switch fabric cards added to a FLASHWAVE 4300 shelf increases VT1.5 switching to 5376x5376, the best in its class.

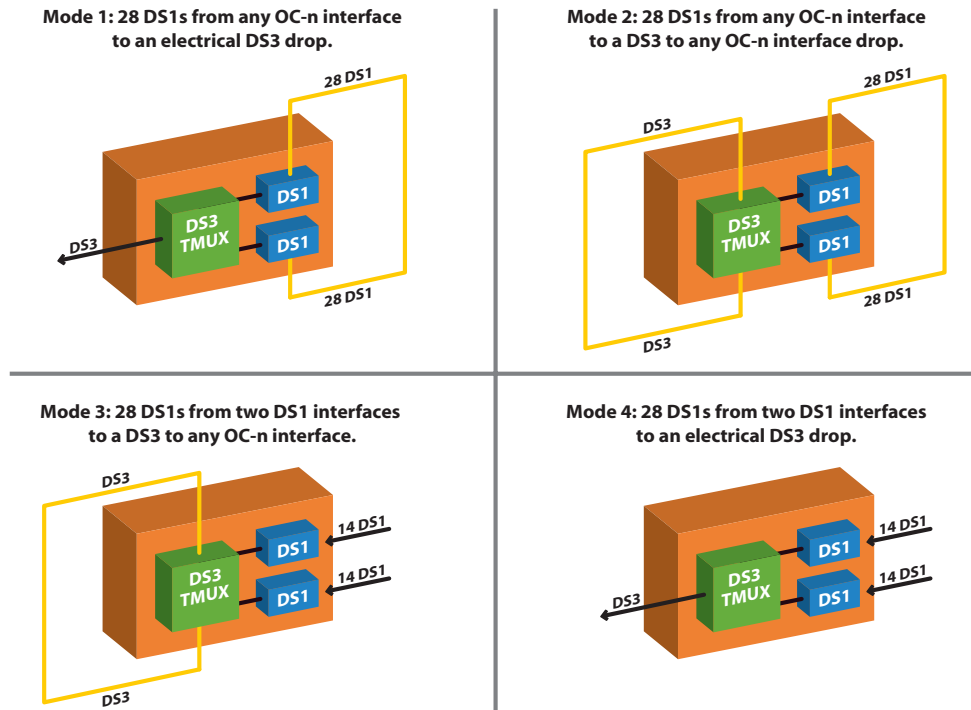

Figure 1: M13 Transmux Modes of Operation

Figure 2 shows a number of potential circuit flows inside the FLASHWAVE 4300 platform to illustrate its VT1.5 switching and M13 multiplexing capabilities. An M13-mapped DS3 can enter the Network Element (NE) either electrically through a BNC connector on the backplane or optically through any OC-n fiber facility. At the DS3 Transmux interface, the M13-mapped DS3 is broken down into constituent DS1s, providing full visibility to every DS1 inside any DS3 in the shelf. These DS1s are then repackaged into 28 individual VT1.5s.

After each DS1 is mapped into its VT1.5, the flexible VT1.5 switch fabric provides any-port-to-any-port connectivity. Each VT1.5 may be bundled with other VT1.5s and sent out through the OC-n facility, dropped as a DS1 within the shelf or sent to a separate M13 transmux interface to be repackaged into another M13-mapped DS3. This DS3 can then leave the DCS electrically (via a BNC connector) or optically (via an OC-n facility) for transport to the Interoffice Facility (IOF) network, access network or external customers.

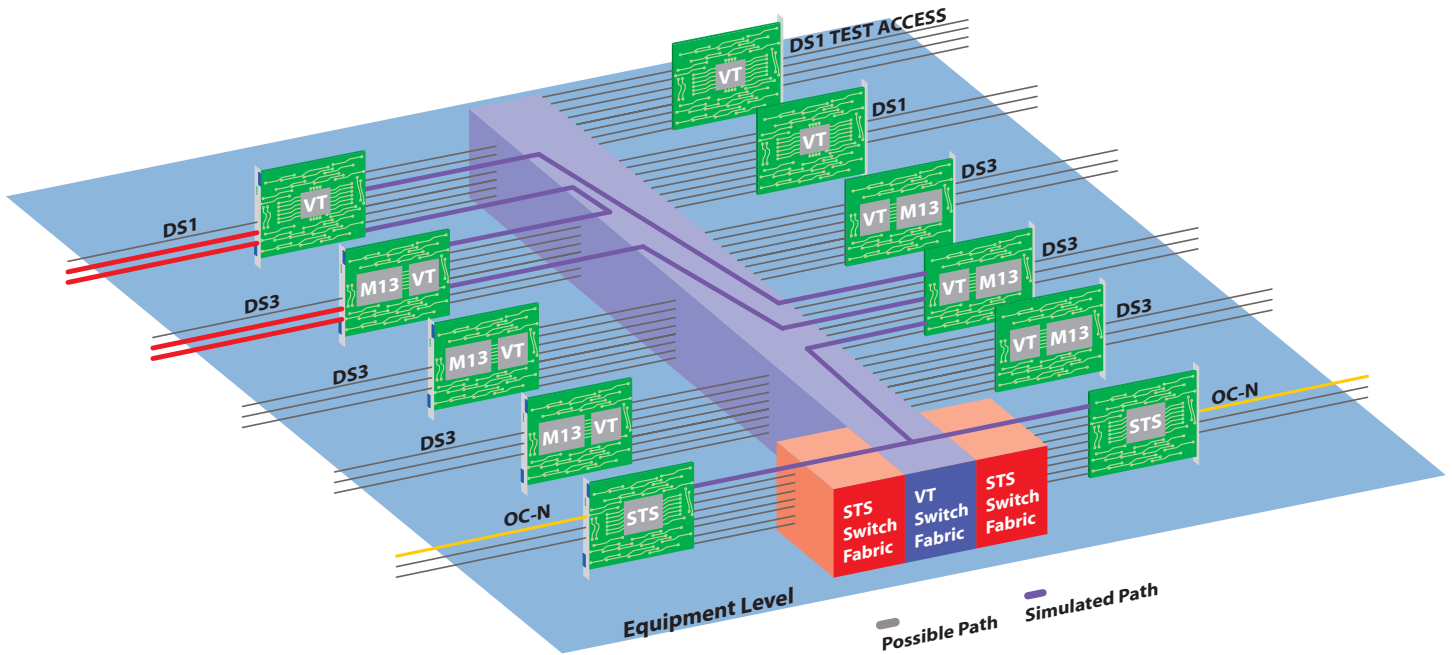

Figure 2: Circuit Flow Examples

With this basic building block in place, the cross-connect device can scale with traffic requirements. To grow the cross-connect, simply add another NE and connect it to the existing shelves with fiber jumpers. Incremental growth capability eliminates the need for a carrier to spend millions of valuable CAPEX dollars on a large cross-connect system that may never be fully utilized. Instead, the Fujitsu DCS solution allows growth in smaller, more cost-efficient increments to scale with business needs.

Figure 3 illustrates how a carrier can expand the DCS. Two electrical DS3s from the backplane are connected to two different DS3 Transmux interfaces in the FLASHWAVE 4300 platform. The DS3 Transmux interface terminates the DS3 and pulls out the individual DS1s. These DS1s are mapped into VT1.5s and sent to the VT1.5 switch fabric where they are mapped into the OC-n facility and transported to the second FLASHWAVE 4300 NE. This second NE utilizes its VT1.5 switch fabric and DS3 Transmux interfaces to map each VT1.5 into its appropriate optical or electrical facility for transport out of the DCS.

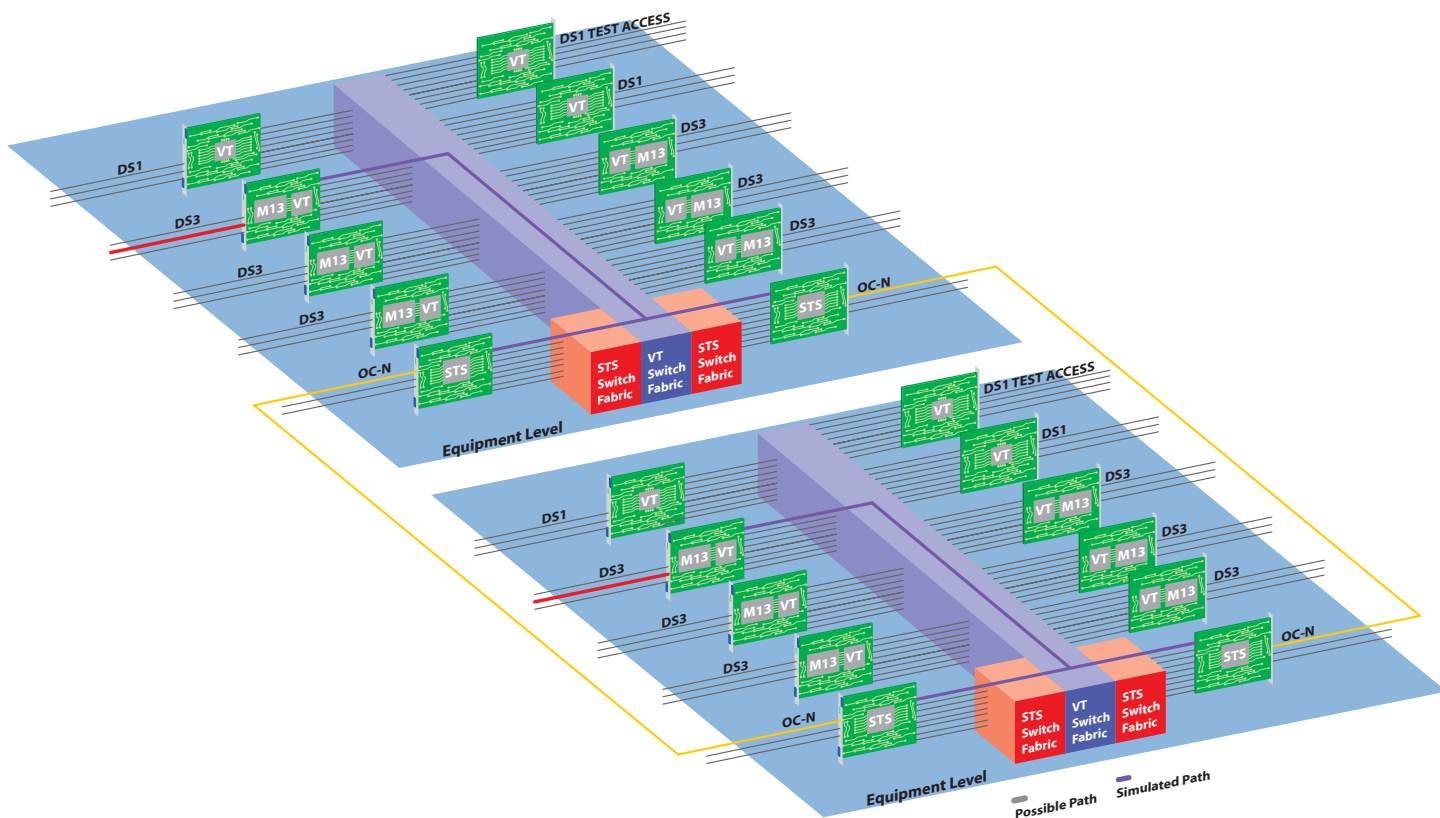

Figure 3: The FLASHWAVE 4300 Platform Easily Scales to Support Growing Traffic Requirements

The FLASHWAVE 4500 platform can be added to the DCS solution when large amounts of STS switching are required. The platform utilizes a massive 1344x1344 STS-1 switch fabric (also best in class) with full TSI to provide core cross-connect capabilities between several FLASHWAVE 4300 nodes. The FLASHWAVE 4500 platform also utilizes an optional VT1.5 switch matrix of 1344x1344 to provide additional VT1.5 switching.

DS1 test access ports on the FLASHWAVE 4300 and FLASHWAVE 4500 platforms allow automated testing of any DS1 circuit in the NE using an external device known as a test head. The test access capabilities include industry standard, non-intrusive DS1 or DS3 Test Access Unit (DTAU) monitoring and intrusive testing functions.



FLASHWAVE Digital Cross-Connect Solutions

The flexibility and scalability inherent in the Fujitsu FLASHWAVE 4300 and FLASHWAVE 4500 platforms offer many options in designing an optimized DCS solution. This section includes examples of how FLASHWAVE products are used to create a robust cross-connect solution.

Application Example 1: Electrical DS3 Signals Only

Figure 4 shows a FLASHWAVE DCS system that provides 60 M13 DS3 ports with visibility to all DS1s in the system. Four identical FLASHWAVE 4300 shelves are used to provide the cross-connect functionality. Each individual shelf contains 15 DS3 Transmux ports and DS1 test access capabilities. The shelves are connected via OC-48 fiber links for inter-shelf transport.

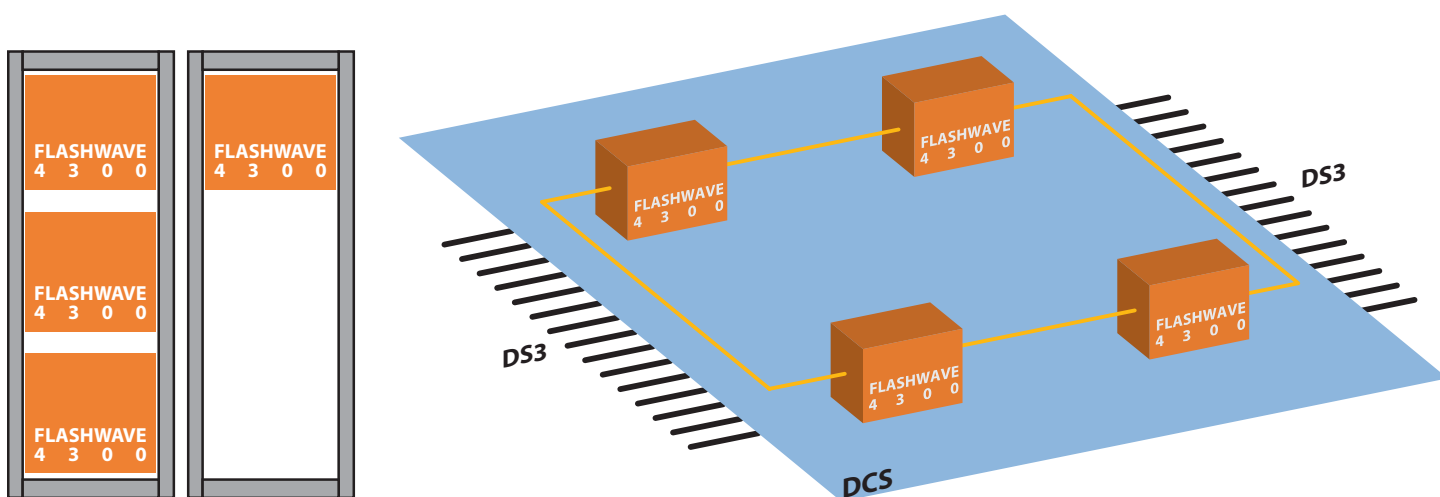

Figure 4: FLASHWAVE DCS System with 60 M13 DS3 Ports

Each DS3 signal is connected electrically to a FLASHWAVE 4300 NE through a BNC connector on the shelf backplane. The DS3 Transmux interface de-multiplexes the DS3 into constituent DS1s and packages them into VT1.5s. Depending on the desired port mapping, the VT1.5 switch fabric will switch VT1.5 signals to another DS3 Transmux port on that shelf or to the OC-48 fiber link for transport to another shelf inside the DCS. Once inside the other shelf, the VT1.5 is cross connected to the appropriate transmux port and transported out of the DCS as an electrical DS3 via another BNC connector on the backplane. In this configuration, any DS1 can be mapped into any DS3 in the DCS. The DCS has access to all DS1s in the system allowing A-to-Z testing of any DS1 circuit.

Figure 5 illustrates how this solution can be easily scaled to support 90 M13 DS3 ports with the addition of two FLASHWAVE 4300 shelves connected via the OC-48 inter-shelf fiber link. This process can be done in-service with no traffic disruption.

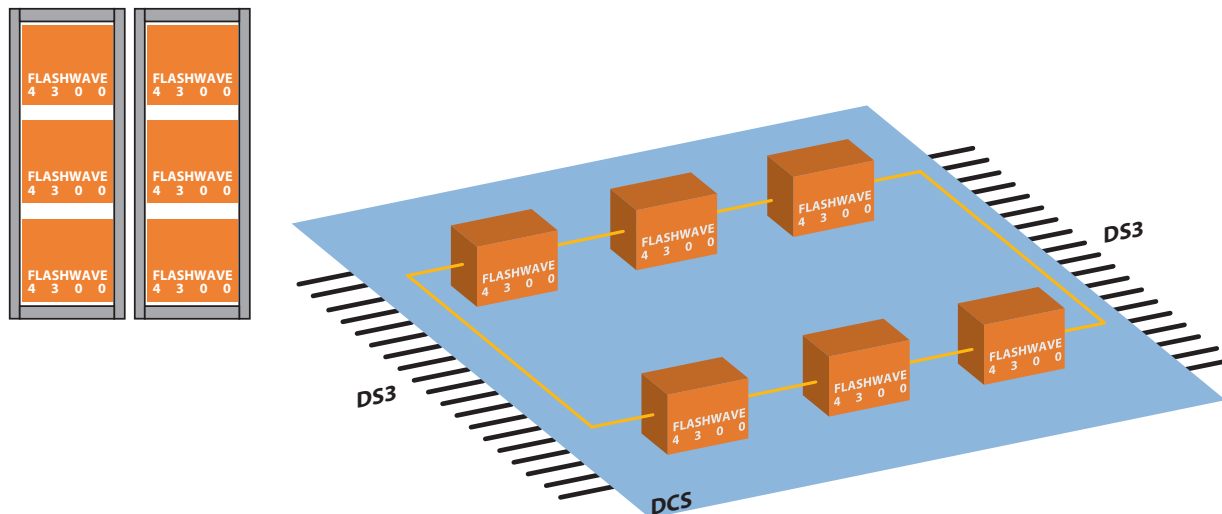

Figure 5: FLASHWAVE DCS System with 90 M13 DS3 Ports

When network requirements grow beyond 90 M13 DS3 ports, a FLASHWAVE 4500 node can be added to provide an interconnection point between the FLASHWAVE 4300 shelves. The FLASHWAVE 4500 platform allows in-service DCS growth to 120 M13 DS3 ports (Figure 6), 180 M13 DS3 ports (Figure 7) or more ports with no traffic disruption.

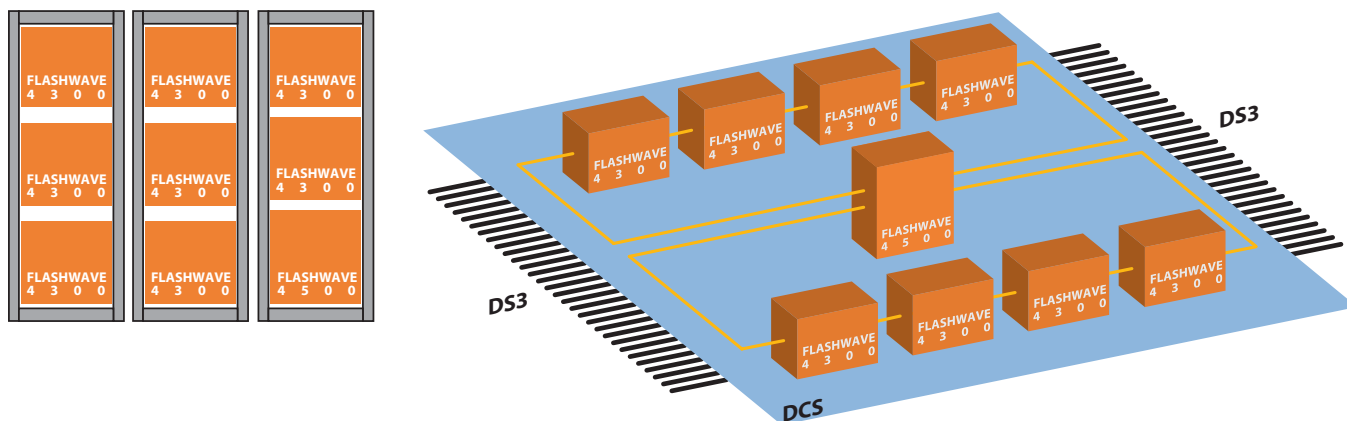

Figure 6: FLASHWAVE DCS System with 120 M13 DS3 Ports



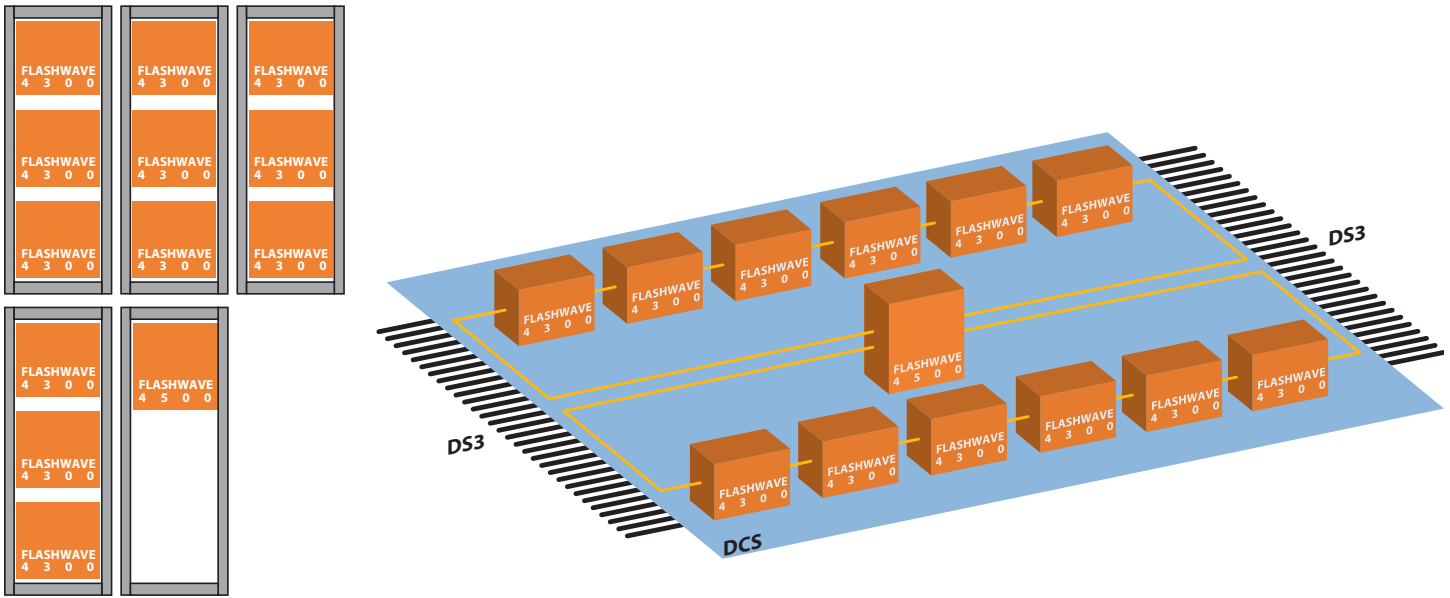

Figure 7: FLASHWAVE DCS System with 180 M13 DS3 Ports

The FLASHWAVE 4300 shelves are configured as in previous examples, with each shelf providing 15 M13 DS3 ports. The FLASHWAVE 4500 shelf is configured with two sets of OC-48 optics. This configuration provides the interconnection point between the M13 DS3 ports maintaining the ability to connect any DS1 from any DS3 to any other DS3 in the DCS. Since the FLASHWAVE 4500 platform can scale to support up to eight OC-48 rings in a single shelf, this configuration provides up to eight OC-48 interconnection points or scalability up to 720 M13 DS3 ports before another FLASHWAVE 4500 node is needed.

Application Example 2: Electrical DS3 and Electrical EC1 Signals

Some DCS applications require both DS3 and EC1 inputs/outputs. Figure 8 shows a configuration that supports 90 M13 DS3s and 90 EC1 signals with full DS1 visibility. In this configuration, the FLASHWAVE 4500 shelf provides the 90 EC1 ports and two sets of OC-48 fiber links to interconnect other shelves in the DCS solution. The FLASHWAVE 4300 shelves are configured as in previous examples, with each shelf providing 15 M13 DS3 ports, for a total of 90 M13 DS3 ports.

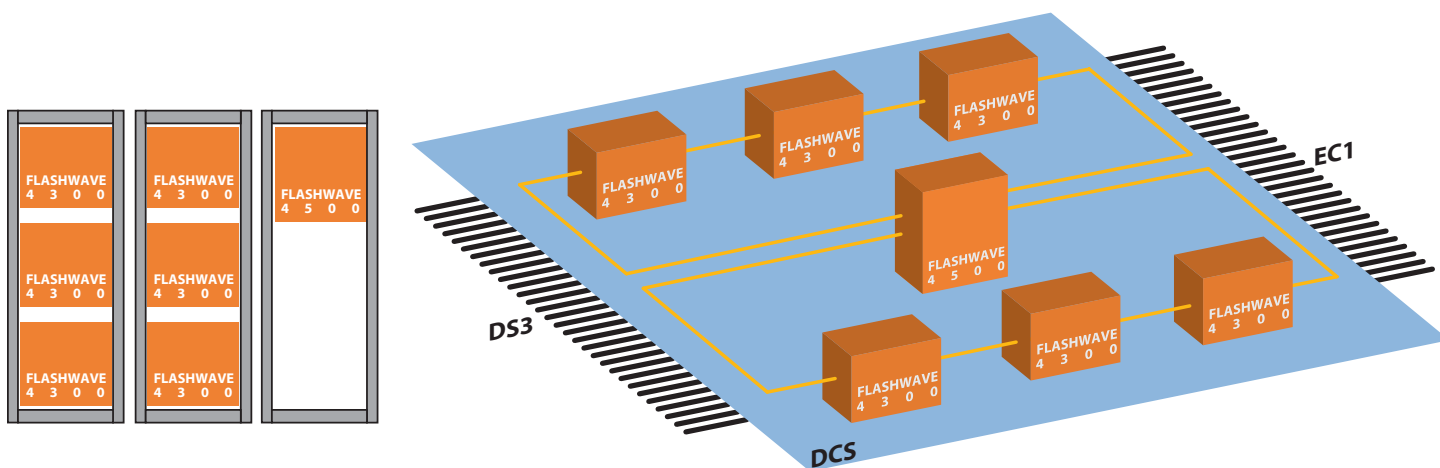

Figure 8: FLASHWAVE DCS System with 90 M13 DS3 and 90 EC1 Ports

EC1 signals carrying VT1.5 traffic enter the DCS via BNC connectors on the backplane of the FLASHWAVE 4500 shelf. The STS switch matrix in the FLASHWAVE 4500 platform cross connects each STS to one of the two OC-48 fiber links. Once inside a FLASHWAVE 4300 shelf, each VT1.5 within each STS is groomed and repacked with VT1.5 connections from M13 DS3 traffic entering from BNC connectors on the backplane of the FLASHWAVE 4300 shelves. The repackaged DS3 signals can exit the DCS via EC1 ports on the FLASHWAVE 4500 shelf or via DS3 ports on the FLASHWAVE 4300 shelf.

Application Example 3: OC-n Subtending Rings and DS3 Electrical Signals

With the advanced feature set of the next-generation FLASHWAVE 4000 products, rings do not need to be terminated on separate ADM nodes and tied electrically to the DCS via DS3 or EC1 connections. The FLASHWAVE 4000 products can terminate multiple SONET rings directly, eliminating the need for adjacent ADMs. Multiple optical interfaces can be populated in each shelf to provide high-density ring termination and DCS grooming.

Figure 9 illustrates an example of a configuration consisting of 90 M13 DS3 ports plus eight OC-12 rings that are transporting M13 DS3s with full visibility to all DS1 signals mapped in the DS3s. This configuration is similar to the EC1 configuration, however, the FLASHWAVE 4500 shelf provides the 16 OC-12 ports in addition to the two sets of OC-48 fiber links used to interconnect other shelves in the DCS solution. The FLASHWAVE 4300 shelves are configured as in previous examples, with each shelf providing 15 M13 DS3 ports, for a total of 90 M13 DS3 ports.

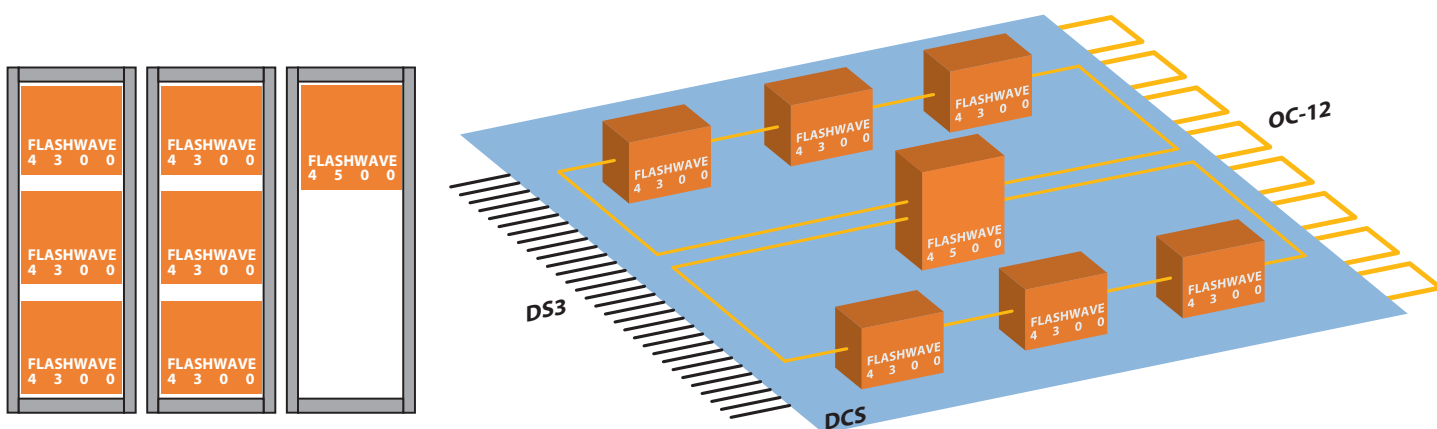

Figure 9: FLASHWAVE DCS System with 8 OC-12 Rings and 90 M13 DS3 Ports

M13-mapped DS3s enter the DCS via subtended OC-12 rings into the FLASHWAVE 4500 platform or via BNC connectors on the backplane of the FLASHWAVE 4300 shelves. The STS switch matrix in the FLASHWAVE 4500 platform cross connects each M13 DS3 from the OC-12 rings to one of the two OC-48 fiber links. Once inside a FLASHWAVE 4300 shelf, each DS3 is terminated on a DS3 Transmux port to access the enclosed DS1s. These DS1s are then groomed and repacked by another DS3 Transmux card on the same shelf or another shelf, depending on the desired mapping. The repackaged DS3 signals can exit the DCS optically via an OC-12 ring on the FLASHWAVE 4500 platform or electrically via BNC connectors on the backplane of the FLASHWAVE 4300 shelf.

Figure 10 shows an example of a Fujitsu DCS configured with 120 DS3s, 8 OC-12s and 12 OC-3s. Two FLASHWAVE 4500 shelves are used to subtend the OC-12 and OC-3 rings in addition to providing OC-48 connectivity between all nodes in the system. The FLASHWAVE 4300 shelves are configured as in previous examples, with each shelf providing 15 M13 DS3 ports, for a total of 90 M13 DS3 ports.

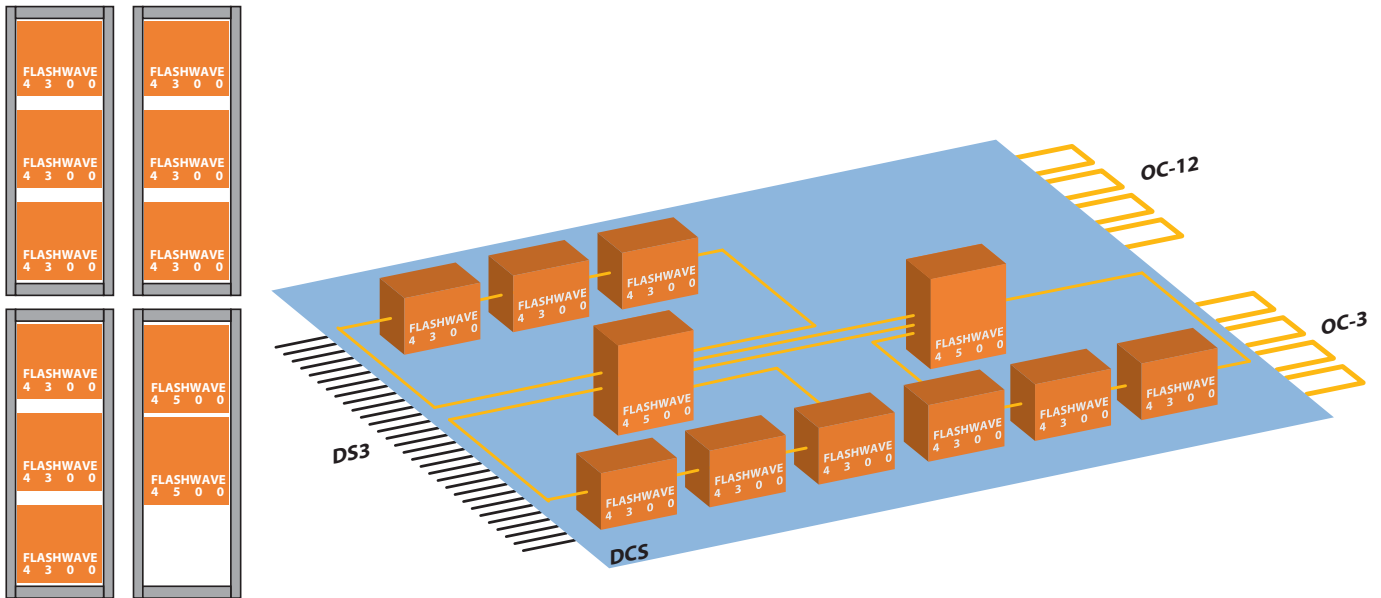

Figure 10: FLASHWAVE DCS System with 8 OC-12 Rings, 12 OC-3 Rings and 120 M13 DS3 Ports

Application Example 4: All OC-n Subtending Rings

The previous examples have assumed that a majority, if not all, of the DS1 traffic entered and exited the DCS through M13 DS3s. This example assumes all DS1 traffic enters and exits the DCS mapped inside VT1.5s, not M13 DS3s.

Figure 11 shows an example of a Fujitsu DCS terminating 8 OC-12 rings, 48 OC-3 rings and 48 EC1 connections. Ring traffic enters a FLASHWAVE 4300 shelf via one of the 8 OC-12 or 16 OC-3 subtended access rings and is directed to the VT1.5 switch fabric where it is groomed and switched to the OC-48 interface. OC-48 fiber links are used to interconnect the FLASHWAVE 4300 shelves to the FLASHWAVE 4500 shelves. The FLASHWAVE 4500 shelves repackage the traffic and send it out optically via one of 32 OC-3 rings or electrically via one of 48 EC1 ports on the backplane. DS1 test access ports provide testing of any DS1 signal inside the DCS.

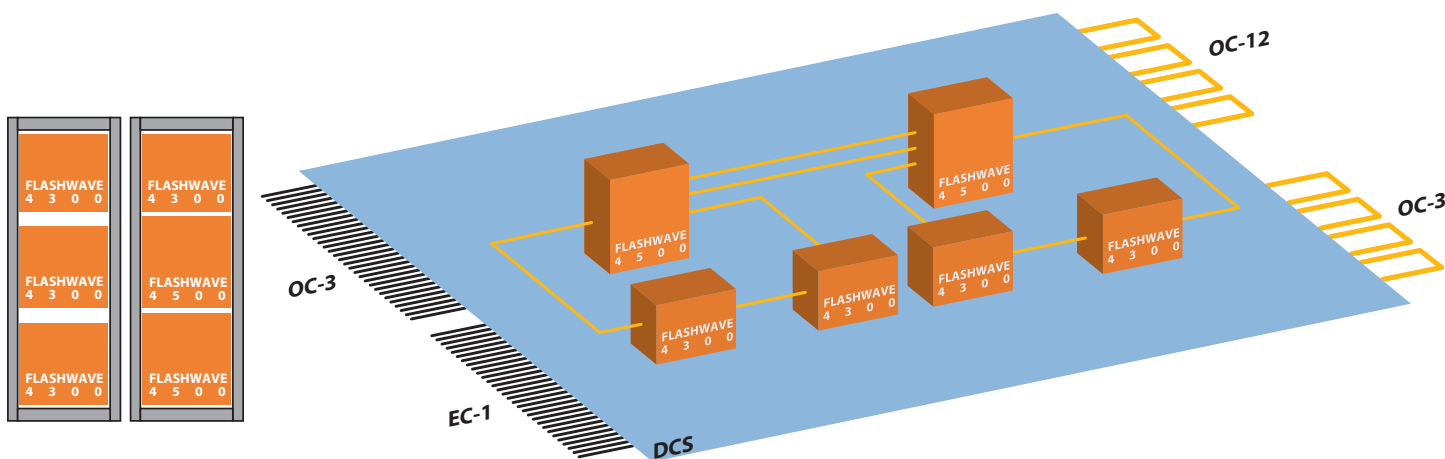

Figure 11: FLASHWAVE DCS System with 8 OC-12 Rings, 48 OC-3 Rings and 48 EC1 Ports

Connection Management

The Fujitsu DCS System can be seamlessly managed by the NETSMART® 1500 Element Management System (EMS). NETSMART 1500 software provides full control over Fujitsu NEs through simplified “point-and-click” provisioning from a centralized location. This integrated solution includes a comprehensive suite of network and element management features for quick and efficient turn-up of Ethernet, DWDM, ATM and SONET services. When new services are introduced, the NETSMART 1500 EMS grows with a carrier’s network to accommodate future expansion and secure existing investments.

Connection Management within the NETSMART 1500 software offers a fully automatic tool for creating end-to-end connections across a network of Fujitsu nodes and DCS systems. Users can select the originating and terminating ends at the desired rate, and the NETSMART 1500 EMS creates the end-to-end connection. The wizard-style interface walks the user through the process and provides choices about how the connection should be built. Connection Management also allows the user to specify the type of protection desired and calculates both the primary and secondary routes.

Once the calculations have been made, the user is presented with both tabular and graphical information about the connection (see Figure 12). The animated graphics indicate the type of ring(s) the connection is traversing and clearly shows the working and protected routes. The user can make modifications to the calculation, if needed, prior to placing the connection in a pending or active (in-service) state.

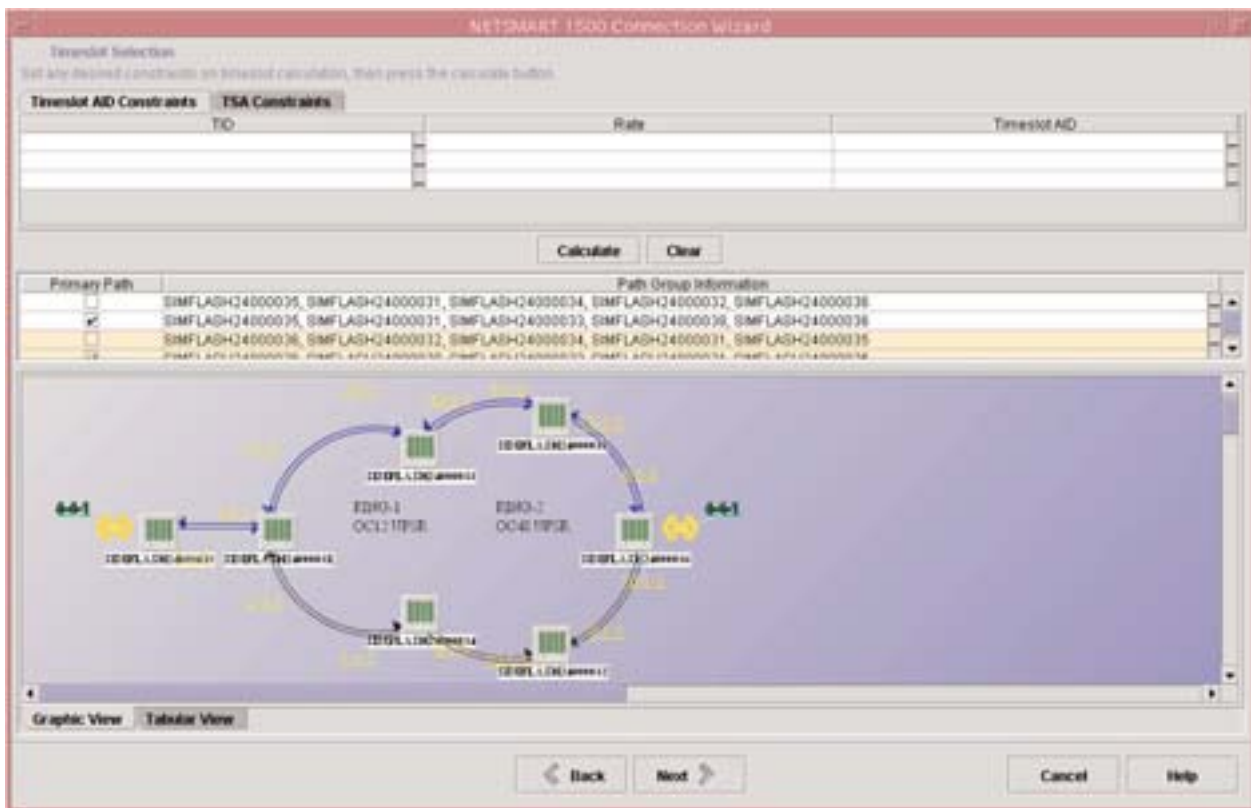

Figure 12: Automatic Connection Management

The NETSMART 1500 software also offers several advanced features, including the ability to set route preferences via node inclusion and/or exclusion. This method is similar to the way road mapping software controls the selection of routes for an automobile trip. The software also offers the ability to create multi-drop (broadcast) connections and build virtually concatenated connections.

All connections are stored within Connection Management (see Figure 13) and can be annotated with customer specific information that can aid the user in trouble-shooting. A search engine easily allows users to find connections using the connection name or other information associated with the connection (e.g. AID, TID, customer name, etc.). Since some cross-connections may have been made outside of Connection Management, the NETSMART 1500 EMS can discover connections anywhere in the network.

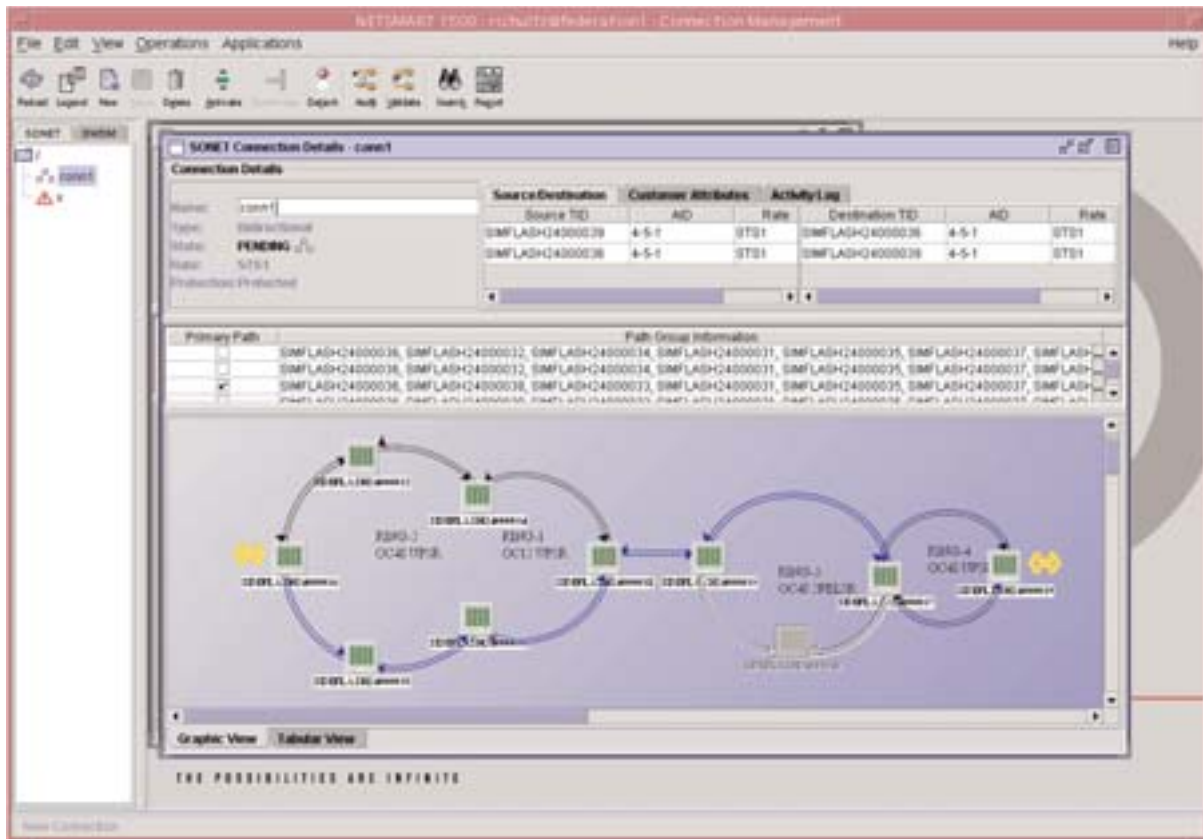

Figure 13: Storing Connections and Related Information

Summary

The FLASHWAVE 4500 and FLASHWAVE 4300 platforms, when combined with the NETSMART 1500 EMS, provide an ideal solution for small- to medium-sized central office DCS requirements. Advanced features and high-capacity STS and VT1.5 switching allow these hardware and software platforms to be integrated to form an optimized, scalable and cost-effective DCS solution. The Fujitsu DCS solution can be easily scaled with capacities from just a few to hundreds of DS3s with both electrical and optical access. Rather than force a carrier to spend a large amount of CAPEX budget up front, the Fujitsu DCS solution allows a carrier to “pay as they grow,” so dollars can be used to add new services, new customers and new revenue-generating opportunities to their network.